

J. R. HOPPER.
ELEVATOR.

No. 454,591.

Patented June 23, 1891.

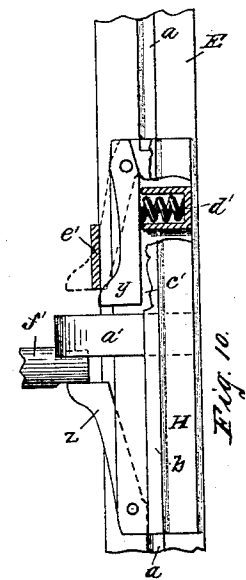
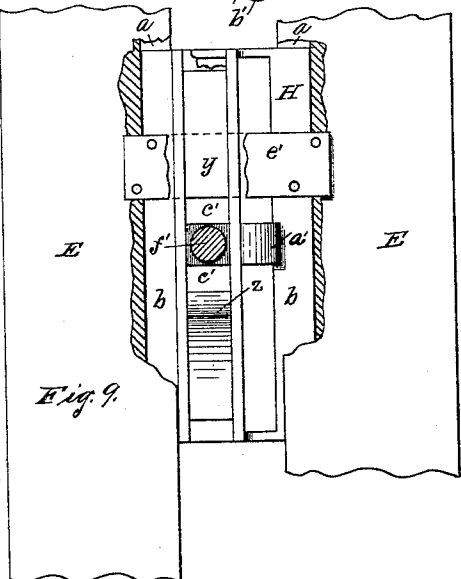
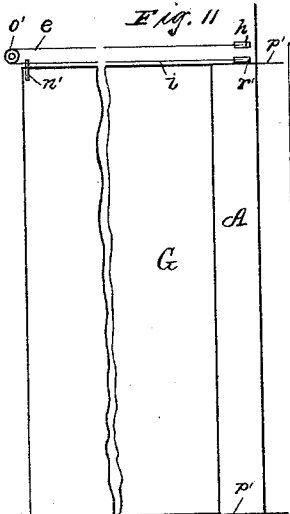
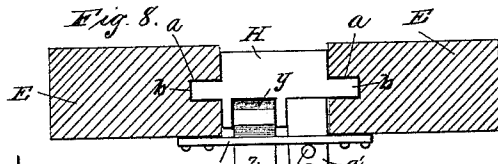
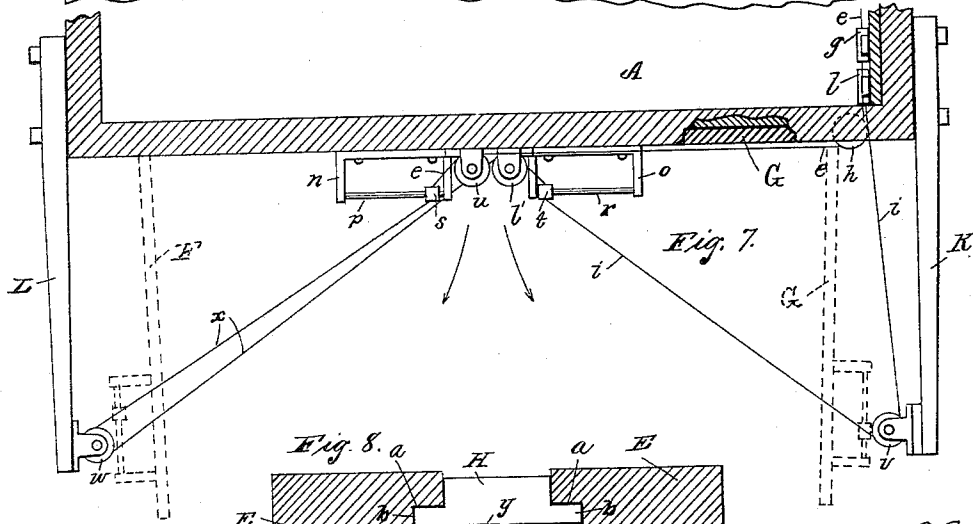
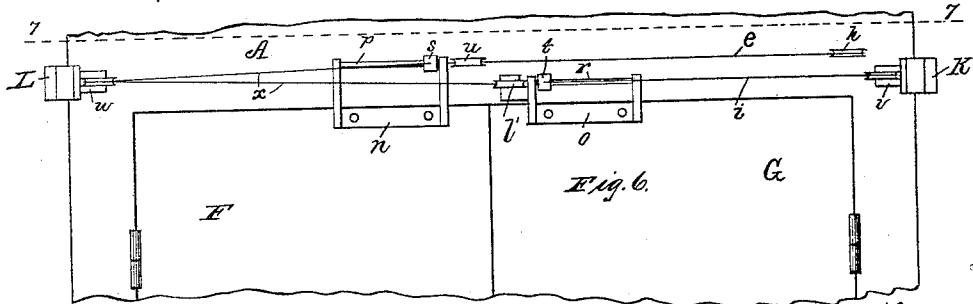

Attest:
 M. L. M. Durmott
 Esq. M. Sleepers.

Inventor:
 John R. Hopper
 By E. B. Whitmore, Atty.

UNITED STATES PATENT OFFICE.

JOHN R. HOPPER, OF ROCHESTER, NEW YORK.

ELEVATOR.

SPECIFICATION forming part of Letters Patent No. 454,591, dated June 23, 1891.

Application filed December 29, 1890. Serial No. 376,092. (No model.)

To all whom it may concern:

Be it known that I, JOHN R. HOPPER, of Rochester, in the county of Monroe and State of New York, have invented a new and useful Improvement in Mechanism for Automatically Operating Elevator-Doors, which improvement is fully set forth in the following specification and shown in the accompanying drawings.

My invention relates more particularly to mechanisms for operating the doors of freight-elevators; and the object of the invention is mainly to construct a mechanism that will both open and close the doors of an elevator well by positive action by the car and without the use of weights, springs, or other devices or machinery independent of the car.

The invention is hereinafter fully described, and more particularly pointed out in the claims.

Referring to the drawings, Figure 1 is a vertical section of a portion of an elevator-well through a doorway; Fig. 2, a horizontal section of parts within the well, taken on the dotted line 2 2 in Fig. 1; Fig. 3, a plan of the operating-bolt and the holder for the same; Fig. 4, a side elevation of the holder for the operating-bolt; Fig. 5, an end elevation of the same; Fig. 6, a front elevation of a part of the exterior of the well and the top of the doors; Fig. 7, a cross-section of a portion of the well on the dotted line 7 7 in Fig. 6; Fig. 8, a horizontal section of the ways, showing more fully the cross-heads; Fig. 9, a front elevation of the cross-head and adjacent part of the ways, parts being broken away; Fig. 10, an edge view of the cross-head with parts broken away to expose its interior construction, and Fig. 11 a view of a sliding door operated by the mechanism.

Referring to the parts shown in the drawings, A is the well of an ordinary freight-elevator, B the guides for the car, and C a doorway opening out onto a floor D of the building.

E are vertical parallel ways extending from the top to the bottom of the well, containing between them a channel r' , with parallel sides. These ways are made of timber and secured in position to the inner face of the wall of the well, preferably near one of the guides B.

F G are the doors for the doorway C, which, as shown, are double, meeting at the middle. These doors are opened and closed automatically and with a positive force by means of cords and other coacting devices operated by the moving car, as hereinafter fully described.

To operate the doors at each story of the building, I employ two similar cross-heads H I to slide in the vertical ways E. These ways are formed with equal longitudinal grooves $a a$, Figs. 8 and 10, on their inner edges, the cross-heads being formed with extended parts or tongues $b b$ to occupy said grooves. These cross-heads stand normally one above the other, as shown in Fig. 1, the distance between them being governed by the extent of the travel of the doors, and are connected by a cord c . This cord passes over a pulley d , secured to one of the ways E just above the upper cross-head, so that when the latter, for instance, is moved downward along the ways the lower cross-head will be caused to move simultaneously upward to meet it, or when the lower cross-head is moved upward the upper cross-head will simultaneously move downward, the motions of the two cross-heads being always directly toward or from each other in the channel between the ways. A cord e is secured to the upper cross-head H and passes downward around a pulley f , secured to the ways E, thence upward around a pulley g and out through the wall of the well around a horizontal pulley h , Figs. 1, 6, and 7. A second cord i is secured to the lower cross-head I, passes downward around pulley k , thence upward and around pulley l , thence out through the wall of the well. When the cross-heads are moved, as above described, the cord i acts to open the doors and the cord e acts to close the doors by means described further on.

The doors F and G, Figs. 6 and 7, are provided with brackets n and o , respectively, holding horizontal rods p and r . These rods are provided with thimbles s and t , fitted to slide freely along them. The cord e extends from the pulley h horizontally around a pulley u , held by the casing above the door, and is connected with the thimble s . The cord i passes around a pulley v , secured at the end of a bar K, extending horizontally outward from the well, thence to the thimble t , to which

it is secured. On the opposite side of the well a bar L, similar to K, is employed holding a pulley *w*. This pulley holds a cord *x*, one end of which is secured to the thimble *t* and the other end to the thimble *s*, the cord passing around a pulley *l'*, secured to the casing above the door. Now from this description it will be understood that when the cross-head I is moved upward by the car the cord *i* will be pulled upon, and from its connection with the door G, as above described, the latter will be swung open or away from the well, as indicated by dotted position in Fig. 7. Now when the door G swings back it will cause the door F to swing back also, on account of the cord *x* connecting the two doors and passing around the pulley *w*, as stated. It will be understood, further, that these motions of the doors will also be produced by the car when descending and carrying the cross-head H downward. As the doors swing open or shut the thimbles slide along the respective rods *p* and *r*, accordingly as the direction of pull upon them varies during the swing of the doors. The pull on the cord *i* is substantially in a direct line between the pulleys *v* and *l'*, and as the door G swings outward it would carry the thimble *t* some distance to the left of that line (as viewed in Fig. 7) were the thimble rigid; but this thimble slides to the right on *r* as the door swings outward, then afterward to the left, so that the line between *v* and *l'* is maintained substantially straight during the whole swing of the door. The action of the thimble *s* is similar and for the same purpose.

The cross-heads H and I are of peculiar construction. They are each provided with two opposing pawls *y* and *z*, Figs. 9 and 10, pivoted near the respective ends of the cross-head. These cross-heads are also each formed with a rigid stud *a'*, pierced with holes *b'*, Fig. 8, to receive the ends of the respective cords. The pawls *y* and *z* occupy a vertical recess or chamber *c'*, in each of the respective cross-heads, and have their free ends projected beyond the sides of the cross-head by springs *d'*, as shown in Fig. 10.

e', Fig. 1, are four metal switch-bars secured to the two ways E E, to cross the channel or space between them at right angles. Their relation with the cross-heads is such that when the latter are carried back of them they serve to force the pawls back into the chambers *c'* against the springs, as clearly shown in Fig. 10. For instance, in the normal positions of the cross-heads, as shown in Fig. 1, the lower pawl *z* of the cross-head I and the upper pawl *y* of the cross-head H are forced back into their respective chambers *c'* by the associated switch-bars, and when the cross-heads are brought near together, as shown in the two dotted intermediate positions, the lower pawl of the cross-head H and the upper pawl of the cross-head I are forced into

the recesses by the two intermediate switch-bars.

The car is provided with a shiftable bolt *f'*, Fig. 10, (more fully shown, however, in Figs. 2 to 5, inclusive,) held in position to encounter one or another of the pawls as the car moves up or down in the well to slide the cross-heads along the ways, as above described. This operating bolt is supported by some convenient holder—as, for instance, a rectangular frame *g'*, secured rigidly to a convenient part *h'* of the car. The bolt is provided with a rigid stud *i'* in position to enter a U-shaped slot *k'* in the end of the frame *g'*. By turning the bolt on its axis to bring the stud in the horizontal part of the slot it may be shifted endwise, so as in the one case to encounter any of the pawls as the car passes, or, in the other case, withdrawn, so as to clear all of the pawls. In the former case the car when ascending or descending operates the doors of the various stories as it passes them, and in the latter case the car passes all the floors without acting upon any of them. The bolt is held in either of its positions by turning it so the stud *i'* shall enter one or the other of the extreme branches of the slot.

The operation of the device is, briefly, as follows: When the car is descending, for instance, the bolt *f'* (being thrown out for action) encounters the pawls *z* of the cross-head H, as indicated in Fig. 10, and carries the cross-head downward to its lower position. (Shown by dotted lines in Fig. 1.) This pulls the lower cross-head I upward to its upper position, (shown also in dotted lines,) in doing which the two doors are thrown open in the manner already described. The bolt is so placed with reference to the floor of the car that said floor is even with the floor D of the building when the cross-head H arrives at its lower position, just stated. When the cross-head reaches said position it comes behind the switch-bar *e'* in such a manner as to cause the latter to force the pawl *z* back into the cross-head out of the way of the bolt, which prevents the cross-head from being carried any farther downward; but when the cross-head is in this position the lower cross-head I is also at its upper position, in which its upper pawl *y* is depressed by the switch-bars *e'* in contact therewith. Now, as the car moves on downward, it passes without touching the lower pawl of the cross-head H and the upper pawl of the cross-head I and encounters the lower pawl of cross-head I, which positions of the parts are also truly represented in Fig. 10. The descending car now forces the cross-head I to its lower or normal position, in doing which it closes the doors by simultaneously carrying the upper cross-head to its upper position and pulling on the cord *e*. These operations are repeated at each floor of the building if it is wished to open and close the doors as the car passes them.

This mechanism is not limited to operating swinging doors like those shown in the principal figures. It may without further invention be adapted to moving other kinds of doors. For instance, Fig. 11 shows its adaptation to a sliding door G. In this case the outriggers K and L, brackets *n* and *o*, cord *x*, and other parts are dispensed with, and the cord *i* is made to turn around a pulley *r'* at the wall of the well, and, like cord *e*, run close to and parallel with said wall, and finally connect directly with the door by a stud *n'*. Thence the cord passes around a pulley *o'*, secured to the casing, and joins the cord *e*, the two cords being continuous, or virtually one and the same. The parts being thus constructed and arranged, a pull on the cord *i* from within the well will cause the door to slide toward the right along the tracks *p' p'* to open the doorway of the well, while a pull by the cord *e* will close the door.

What I claim as my invention is—

1. A mechanism for operating doors of elevator-wells, consisting of parallel ways within the well, coacting movable cross-heads held in the ways, a cord connecting the cross-heads, a pair of movable doors held to close the doorway, a cord connecting the lower cross-head with one of the doors, a cord connecting the upper cross-head with the other door, a cord connecting the two doors, and pulleys for the cords to run upon, substantially as shown and described.

2. A mechanism for operating the doors of an elevator-well, consisting of parallel ways in the well and two coacting movable cross-heads held by the ways, and a cord connecting said cross-heads, in combination with doors acting together to close a doorway, cords connecting each cross-head with a door, carrying-pulleys for the several cords, a shiftable bolt on the car to operate the cross-heads, and a frame or holder for the bolt formed with a U-shaped or crooked slot, the bolt being provided with an extended part to enter

said slot, the ends of the latter forming stops or rests for the bolt, substantially as shown and described.

3. A mechanism for operating doors of elevator-wells, consisting of parallel ways within the well, coacting movable cross-heads held in the ways, a cord connecting the lower cross-head with one of the doors, a cord connecting the upper cross-head with the other door, a cord connecting the two doors, and pulley-carrying arms K L, reaching out from the front of the doors, to operate substantially as and for the purpose set forth.

4. A device for operating a door of an elevator-well, consisting of a channel or raceway with parallel sides within the well, two cross-heads held to move in a line directly toward or from each other, but not to pass each other in the channel, a cord to connect the cross-heads, a movable door for the well, a cord connecting the upper cross-head with said door, a cord connecting the lower cross-head with the door, and pulleys to carry the various cords, each of the two cross-heads being connected directly and independently with the door, whereby the door is moved in either direction by an upward motion of the cross-head controlling it during said motion, substantially as described.

5. The doors F and G of an elevator-well, provided, respectively, with sliding thimbles *s* and *t*, in combination with cord *i*, secured to the thimble *t*, cord *e*, secured to the thimble *s*, cord *x*, connecting said thimbles, pulley *v* for the cord *i*, pulley *u* for the cord *e*, and pulleys *l'* and *w* for the cord *x*, substantially as shown and described.

In witness whereof I have hereunto set my hand this 26th day of December, 1890, in the presence of two subscribing witnesses.

JOHN R. HOPPER.

Witnesses:

ENOS B. WHITMORE,
M. D. PHILLIPS.