

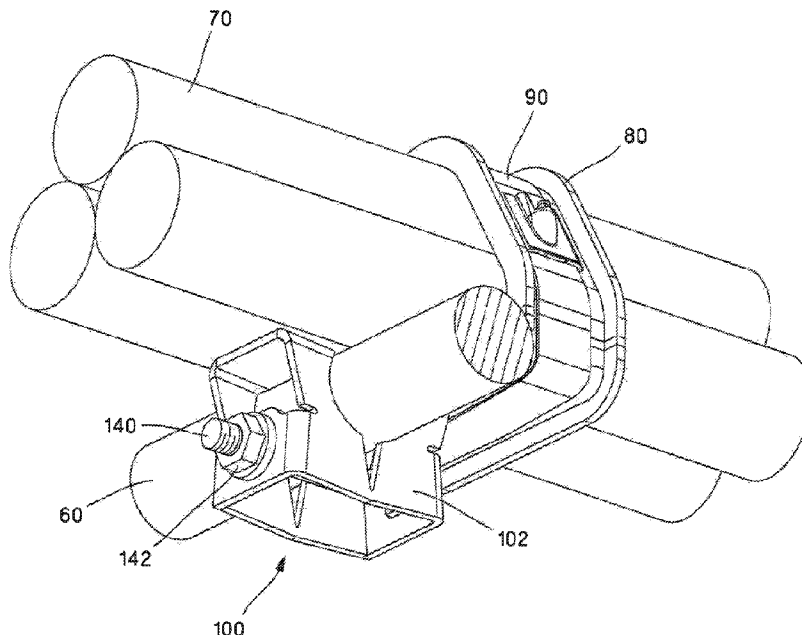

(86) Date de dépôt PCT/PCT Filing Date: 2015/03/23
 (87) Date publication PCT/PCT Publication Date: 2015/10/01
 (45) Date de délivrance/Issue Date: 2021/08/10
 (85) Entrée phase nationale/National Entry: 2016/09/22
 (86) N° demande PCT/PCT Application No.: US 2015/021937
 (87) N° publication PCT/PCT Publication No.: 2015/148345
 (30) Priorités/Priorities: 2014/03/25 (US61/970,143);
 2015/03/20 (US14/664,278)

(51) Cl.Int./Int.Cl. *H02G 3/32* (2006.01),
H02G 3/00 (2006.01), *H02G 3/04* (2006.01)
 (72) Inventeurs/Inventors:
 SYLVESTER, DAVID J., US;
 ROULEAU, RODNEY G., US;
 HILL, RAYMOND M., US;
 CROUSE, ANDREW, US
 (73) Propriétaire/Owner:
 PANDUIT CORP., US
 (74) Agent: MARKS & CLERK

(54) Titre : ENSEMBLE SUPPORT D'ATTACHE DE BERCEAU
 (54) Title: CRADLE CLAMP BRACKET ASSEMBLY



(57) **Abrégé/Abstract:**

A cradle clamp bracket assembly is disclosed that is efficiently installed thereby significantly reducing installation time and labor costs, while increasing productivity. The cradle clamp bracket assembly secures cables to rungs of a ladder rack. The cradle clamp bracket assembly includes an elongated bracket having a first portion and a raised second portion. The first portion includes a slot located along the center of the first portion. The raised second portion includes a downwardly extending flange and at least one gusset to strengthen the bracket. The cradle clamp bracket assembly also includes a retainer that is received in the slot to engage the rung of the ladder rack to secure the cradle clamp bracket assembly.

ABSTRACT

A cradle clamp bracket assembly is disclosed that is efficiently installed thereby significantly reducing installation time and labor costs, while increasing productivity. The cradle clamp bracket assembly secures cables to rungs of a ladder rack. The cradle clamp bracket assembly includes an elongated bracket having a first portion and a raised second portion. The first portion includes a slot located along the center of the first portion. The raised second portion includes a downwardly extending flange and at least one gusset to strengthen the bracket. The cradle clamp bracket assembly also includes a retainer that is received in the slot to engage the rung of the ladder rack to secure the cradle clamp bracket assembly.

CRADLE CLAMP BRACKET ASSEMBLY

Background of the Invention

[0001] The present invention relates to a bracket assembly, and more particularly to a cradle clamp bracket assembly for securing cables to the rungs of a ladder rack.

[0002] Conventional cable cleats have been typically used to secure wire or cable bundles to panels, ladder racks, or similar structural members. The cable cleats include a mounting surface and a body portion that receives the wires or a cable bundles. Conventional cable cleats, however, are generally difficult and time consuming to install. Thus, it is desirable to provide a bracket assembly that is efficiently installed thereby significantly reducing labor costs and increasing productivity.

Summary of the Invention

[0003] The present invention is directed to a cradle clamp bracket assembly that secures cables to rungs of a ladder rack. The cradle clamp bracket assembly includes an elongated bracket with a first portion and a raised second portion. The first portion has a slot located along a center of the bracket. The second portion has a downwardly extending flange and at least one gusset for strengthening the bracket. The cradle clamp bracket assembly also includes a retainer that is received in the slot and engages the rung of the ladder rack to secure the cradle clamp bracket assembly.

[0004] Another embodiment of the cradle clamp bracket assembly may include a bracket having an elongated slot and a raised member. The elongated slot extends the length of the bracket at a center of the bracket. A retainer bracket is positioned in the elongated slot. The retainer bracket includes a vertical member and a horizontal member with an opening therethrough for receiving a fastener. A ladder rack is positioned on the bracket between the retainer bracket and the raised member. The fastener is tightened such that the horizontal member of the retainer bracket engages the ladder rack to secure the cradle clamp bracket assembly.

[0005] Another embodiment of the cradle clamp bracket assembly may include a bracket having a recessed area with a slot and a raised member. A ladder rung nut is positioned in the recessed area. A

fastener extends through the slot of the recessed area into the ladder rung nut and a compression spring engages the fastener. The cradle clamp bracket assembly is positioned under the ladder rack and the ladder rung nut is tightened to engage the ladder rack thereby securing the cradle clamp bracket assembly.

According to an aspect of the present invention, there is provided a cradle clamp bracket secured to a ladder rack for securing at least one cable to the ladder rack, the cradle clamp bracket and ladder rack assembly comprising:

a ladder rung;

an elongated bracket having a first portion, a middle portion, a raised second portion parallel to the first portion, and a flange extending downwardly from the raised second portion, wherein the first portion receives the ladder rung, the ladder rung adapted to receive the at least one cable;

wherein the first portion having a slot located along a center of the first portion;

wherein the second portion having at least one gusset for strengthening the bracket, the second portion adapted to support the at least one cable and to receive a tie to secure the at least one cable to the second portion of the bracket; and

a retainer received in the slot, wherein the retainer engages the ladder rung received on the first portion.

According to another aspect of the present invention, there is provided a cradle clamp bracket secured to a ladder rack for securing at least one cable to the ladder rack, the cradle clamp bracket and ladder rack assembly comprising:

a ladder rung;

a bracket having an elongated slot and a raised member;

wherein the elongated slot extends a length of the bracket at a center of the bracket;

a retainer bracket having a vertical member positioned in the elongated slot and a horizontal member with an opening therethrough; and

a fastener extending through the opening in the horizontal member of the retainer bracket, the ladder rung is positioned on the bracket between the retainer bracket and the raised member, as the fastener is tightened the horizontal member of the retainer bracket engages the ladder rung to secure the cradle clamp bracket,

whereby the at least one cable is positioned on the ladder rung bracket, the raised member supports the at least one cable and a tie secures the at least one cable to the raised member of the bracket.

According to another aspect of the present invention, there is provided a cradle clamp bracket and ladder rack assembly comprising:

a ladder rung;

at least one cable;

an elongated bracket having a first portion, a middle portion, a raised second portion parallel to the first portion, wherein the first portion receives the ladder rung and the ladder rung receives the at least one cable;

wherein the first portion having a slot located along a center of the first portion;

wherein the second portion having at least one gusset for strengthening the bracket, the second portion supports the at least one cable and receives a tie to secure the at least one cable to the second portion of the bracket; and

a retainer received in the slot, wherein the retainer engages the ladder rung received on the first portion.

According to another aspect of the present invention, there is provided a cradle clamp bracket secured to a ladder rack for securing at least one cable to the ladder rack, the cradle clamp bracket and ladder rack assembly comprising:

a ladder rung;

a bracket having a first portion, a middle portion, and a raised second portion parallel to the first portion, the first portion having a recessed area with a slot;

a ladder rung nut received in the recessed area;

a fastener extending through the slot of the recessed area into the ladder rung nut; and

a compression spring engaging the fastener;

the bracket is positioned under the ladder rung and the ladder rung nut is tightened to engage the ladder rung thereby securing the cradle clamp bracket to the ladder rack; and

whereby the at least one cable is positioned on the ladder rung, the raised second portion of the bracket supports the at least one cable, and a tie secures the at least one cable to the raised second portion.

According to another aspect of the present invention, there is provided a cradle clamp bracket and ladder rack assembly comprising:

a ladder rung;

the bracket being elongated and having a first portion, a middle portion, a raised second portion parallel to the first portion, and a flange extending downwardly from the raised

second portion, wherein the first portion receives the ladder rung, the ladder rung adapted to receive at least one cable;

wherein the first portion having a slot located along a center of the first portion;

wherein the second portion having at least one gusset for strengthening the bracket, the second portion adapted to support the at least one cable and to receive a tie to secure the at least one cable to the second portion of the bracket; and

a retainer received in the slot, wherein the retainer engages the ladder rung received on the first portion.

According to another aspect of the present invention, there is provided a cradle clamp bracket and ladder rack assembly comprising:

a ladder rung;

the bracket having an elongated slot and a raised member; wherein the elongated slot extends a length of the bracket at a center of the bracket;

a retainer bracket having a vertical member positioned in the elongated slot and a horizontal member with an opening therethrough; and

a fastener extending through the opening in the horizontal member of the retainer bracket,

the ladder rung is positioned on the bracket between the retainer bracket and the raised member, as the fastener is tightened the horizontal member of the retainer bracket engages the ladder rung to secure the cradle clamp bracket,

whereby at least one cable is positioned on the ladder rung and the bracket, the raised member supports the at least one cable and a tie secures the at least one cable to the raised member of the bracket.

Brief Description of the Drawings

[0006] FIG. 1 is a perspective view of the first embodiment of the cradle clamp bracket assembly installed on a ladder rung.

[0007] FIG. 2 is a top left perspective view of the cradle clamp bracket assembly of FIG. 1 installed on a ladder rung.

[0008] FIG. 3 is a bottom left perspective view of the cradle clamp bracket assembly of FIG. 1 installed on a ladder rung.

[0009] FIG. 4 is a bottom right perspective view of the cradle clamp bracket assembly of FIG. 1 installed on a ladder rung.

[0010] FIG. 5 is a perspective view of the cradle clamp bracket assembly of FIG. 1.

[0011] FIG. 6 is an exploded view of the cradle clamp bracket assembly of FIG. 5.

[0012] FIG. 7 is a side view of the cradle clamp bracket assembly of FIG. 1 positioned on a ladder rung.

[0013] FIG. 8 is a side view of the cradle clamp bracket assembly of FIG. 7 with the nut tightened to secure the cradle clamp bracket assembly to the ladder rung.

[0014] FIG. 9 is a partially exploded perspective view of the cradle clamp bracket assembly of FIG. 2 positioned to receive the cables, cushion sleeve and stainless steel tie or strap.

[0015] FIG. 10 is a cross sectional view of the cradle clamp bracket assembly installed on a ladder rung of FIG. 2 taken along line 10-10.

[0016] FIG. 11 is a top perspective view of the second embodiment of the cradle clamp bracket assembly of the present invention installed on a ladder rung.

[0017] FIG. 12 is a bottom perspective view of the cradle clamp bracket assembly installed on a ladder rung of FIG. 11.

[0018] FIG. 13 is an exploded perspective view of the cradle clamp bracket assembly of FIG. 11.

[0019] FIG. 14 is an assembled perspective view of the cradle clamp bracket assembly of FIG. 13.

[0020] FIG. 15 is a cross sectional view of the cradle clamp bracket assembly of FIG. 14 positioned on a ladder rung.

[0021] FIG. 16 is a cross sectional view of the cradle clamp bracket assembly installed on the ladder rung of FIG. 11 with cables, cushion sleeve and stainless steel tie or strap secured thereto.

[0022] FIG. 17 is a top perspective view of the third embodiment of the cradle clamp bracket assembly of the present invention installed on a ladder rung.

[0023] FIG. 18 is a bottom perspective view of the cradle clamp bracket assembly installed on a ladder rung of FIG. 17.

[0024] FIG. 19 is an exploded perspective view of the cradle clamp bracket assembly of FIG. 17.

[0025] FIG. 20 is an assembled perspective view of the cradle clamp bracket assembly of FIG. 19 with a ladder rung positioned to be installed.

[0026] FIG. 21 is a cross sectional view of the cradle clamp bracket assembly and ladder rung of FIG. 20.

[0027] FIG. 22 is a cross sectional view of the cradle clamp bracket assembly of FIG. 21 taken along line 22-22.

[0028] FIG. 23 is a cross sectional view of the cradle clamp bracket assembly of FIG. 21 with the ladder rung installed in the cradle clamp bracket assembly and the nut secured to the J hook.

[0029] FIG. 24 is a cross sectional view of the cradle clamp bracket assembly of FIG. 23 taken along line 24-24.

[0030] FIG. 25 is a perspective view of the fourth embodiment of the cradle clamp bracket assembly installed on a ladder rung.

[0031] FIG. 26 is a bottom perspective view of the cradle clamp bracket assembly of FIG. 25 installed on a ladder rung.

[0032] FIG. 27 is an exploded perspective view of the cradle clamp bracket assembly of FIG. 25.

[0033] FIG. 28 is a bottom perspective view of the retainer bracket of FIG. 27.

[0034] FIG. 29 is an assembled perspective view of the cradle clamp bracket assembly of FIG. 27 positioned to be installed on a ladder rung.

[0035] FIG. 30 is a cross sectional view of the cradle clamp bracket assembly taken along line 30-30 of FIG. 29.

[0036] FIG. 31 is a cross sectional view of the cradle clamp bracket assembly taken along line 31-31 of FIG. 29.

[0037] FIG. 32 is a cross sectional view of the cradle clamp bracket assembly of FIG. 25 installed on a rectangular ladder rung.

[0038] FIG. 33 is a perspective view of the cradle clamp bracket assembly of FIG. 25 installed on a ladder rung with flanged ends.

[0039] FIG. 34 is a bottom perspective view of the cradle clamp bracket assembly and ladder rung of FIG. 33.

[0040] FIG. 35 is a perspective view of the cradle clamp bracket assembly of FIG. 25 installed on a round ladder rung.

[0041] FIG. 36 is a side view of the cradle clamp bracket assembly and ladder rung of FIG. 35.

[0042] FIG. 37 is a perspective view of an alternative cradle clamp bracket assembly installed on a top hat ladder rung.

[0043] FIG. 38 is a bottom perspective view of the cradle clamp bracket assembly of FIG. 37.

[0044] FIG. 39 is a bottom perspective view of the retainer bracket of the cradle clamp bracket assembly of FIG. 37.

[0045] FIG. 40 is a cross sectional view of the cradle clamp bracket assembly and top hat ladder rung taken along line 40-40 of FIG. 37.

[0046] FIG. 41 is a cross sectional view of the cradle clamp bracket assembly taken along line 41-41 of FIG. 40.

[0047] FIG. 42 is a perspective view of the cradle clamp bracket assembly of FIG. 37 installed on a strut rung.

[0048] FIG. 43 is a cross sectional view of the cradle clamp bracket assembly taken along line 43-43 of FIG. 42.

[0049] FIG. 44 is a perspective view of the cradle clamp bracket assembly of FIG. 37 installed on a beam rung.

[0050] FIG. 45 is a cross sectional view of the cradle clamp bracket assembly taken along line 45-45 of FIG. 44.

[0051] FIG. 46 is a top perspective view of the fifth embodiment of the cradle clamp bracket assembly installed on a ladder rung.

[0052] FIG. 47 is a bottom perspective view of the cradle clamp bracket assembly of FIG. 46 installed on a ladder rung.

[0053] FIG. 48 is an exploded perspective view of the cradle clamp bracket assembly of FIG. 46.

[0054] FIG. 49 is a top perspective view of the cradle clamp bracket assembly of FIG. 48 positioned to be secured to a ladder rack.

[0055] FIG. 50 is a cross sectional view of the cradle clamp bracket assembly and ladder rack taken along line 50-50 of FIG. 49.

[0056] FIG. 51 is a cross sectional view of the cradle clamp bracket assembly and ladder rack taken along line 51-51 of FIG. 46.

[0057] FIG. 52 is a perspective view of the cradle clamp bracket assembly of FIG. 46 positioned on an alternative width ladder rung.

[0058] FIG. 52A is a perspective view of the cradle clamp bracket assembly installed on a top hat ladder rung.

[0059] FIG. 52B is a perspective view of the cradle clamp bracket assembly installed on a beam rung.

[0060] FIG. 53 is a cross sectional view of the cradle clamp bracket assembly and ladder rack taken along line 53-53 of FIG. 52.

[0061] FIG. 53A is a side view of the cradle clamp bracket assembly and top hat ladder rung of FIG. 52A.

[0062] FIG. 53B is a side view of the cradle clamp bracket assembly and the beam rung of FIG. 52B.

[0063] FIG. 54 is a perspective view of a sixth embodiment of the cradle clamp bracket assembly installed on a ladder rung.

[0064] FIG. 55 is a bottom perspective view of the cradle clamp bracket assembly of FIG. 54 installed on a ladder rung.

[0065] FIG. 56 is a perspective view of the cradle clamp bracket assembly of FIG. 54.

[0066] FIG. 57 is an exploded perspective view of the cradle clamp bracket assembly of FIG. 54.

[0067] FIG. 58 is a perspective view of the cradle clamp bracket assembly of FIG. 54 prior to being secured to the ladder rung.

[0068] FIG. 59 is a cross sectional view of the cradle clamp bracket assembly of FIG. 58 taken along line 59-59.

[0069] FIG. 60 is a cross sectional view of the cradle clamp bracket assembly of FIG. 59 taken along line 60-60.

[0070] FIG. 61 is a perspective view of the cradle clamp bracket assembly of FIG. 54 being secured to the ladder rung.

[0071] FIG. 62 is a cross sectional view of the cradle clamp bracket assembly of FIG. 61 taken along line 62-62.

[0072] FIG. 63 is a cross sectional view of the cradle clamp bracket assembly of FIG. 62 secured to the ladder rung.

[0073] FIG. 64 is a perspective view of a seventh embodiment of the cradle clamp bracket assembly installed on a ladder rung.

[0074] FIG. 65 is a perspective view of the cradle clamp bracket assembly of FIG. 64.

[0075] FIG. 66 is an exploded perspective view of the cradle clamp bracket assembly of FIG. 64.

[0076] FIG. 67 is a side view of the cradle clamp bracket assembly of FIG. 64 positioned to be installed on a ladder rung.

[0077] FIG. 68 is a cross sectional view of the cradle clamp bracket assembly of FIG. 67 taken along line 68-68.

[0078] FIG. 69 is a side view of the cradle clamp bracket assembly of FIG. 64 partially installed on a ladder rung.

[0079] FIG. 70 is a cross sectional view of the cradle clamp bracket assembly of FIG. 69 taken along line 70-70.

[0080] FIG. 71 is a side view of the cradle clap bracket assembly of FIG. 64.

Detailed Description

[0081] The cradle clamp bracket assembly of the present invention secures at least one cable 70 to a ladder rung 60 using a stainless steel tie or strap 90. As described below, the bracket assembly is placed under the ladder rung 60 and secured thereto. A cushion sleeve 80 is wrapped around the cables 70 and a stainless steel tie or strap 90 is wrapped underneath one end of the bracket and the cushion sleeve 80 thereby securing the cables 70 to the ladder rung 60.

[0082] FIGS. 1-10 illustrate a first embodiment of a cradle clamp bracket assembly 100. As illustrated in FIGS. 5 and 6, the cradle clamp bracket assembly 100 includes a one piece metal bracket 102, a carriage bolt 140 and a hex nut 142. The bracket 102 includes a top 104, a bottom 106, a first side 108, a second side 110, a first end 112 and a second end 114. The top 104 of the bracket 102 defines

an opening 120 for receiving various sized ladder rungs. The top 104 of the bracket 102 also defines contact points 122 which engage the ladder rung 60 when the cradle clamp bracket assembly 100 is secured. The top 104 of the bracket 102 includes a gusset 124 and a downwardly extending flange 126. The gusset 124 increases the strength of the bracket 102. Each side 108, 110 of the bracket includes an opening 128 for the ladder rung 60 and a V-shaped notch 130. The V-shaped notches 130 enable the bracket 102 to engage the ladder rung 60 when the nut 142 is tightened. A first end 112 of the bracket 102 includes a circular opening 132 and a second end 114 of the bracket 102 includes a rectangular opening 134 for receiving the carriage bolt 140.

[0083] FIGS. 7-10 illustrate the installation of the cradle clamp bracket assembly 100. As illustrated in FIG. 7, the bracket 102 is placed under a ladder rung 60. Next, as illustrated in FIG. 8, the nut 142 is tightened to secure the bracket assembly 100 to the ladder rung 60. The contact points 122 engage the ladder rung 60 creating a contact force on the ladder rung 60 thereby controlling the lateral and rotational movement of the ladder rung 60. As illustrated in FIG. 9, a cushion sleeve 80 is wrapped around the cables 70. The cushion sleeve 80 and cables 70 are positioned on the top 104 of the bracket 102. The stainless steel tie or strap 90 is wrapped around the cushion sleeve 80 and under the bracket 102 as illustrated in FIGS. 4 and 10. A tool (not illustrated) is used to tension the tie or strap 90 to complete the installation of the cradle clamp bracket assembly 100.

[0084] FIGS. 11-16 illustrate a second embodiment of a cradle clamp bracket assembly 200. As illustrated in FIG. 13, the cradle clamp bracket assembly 200 includes a retainer bracket 202, a metal bracket 222, a carriage bolt 246 and a nut 248. The retainer bracket 202 includes a top 204 with a contact point 206, a bottom 208, a first side 210, a second side 212 and an end 214. The end 214 includes a circular opening 216 for receiving the carriage bolt 246 when the bracket is assembled. The first side 210 and the second side 212 include edges 218, 220, respectively, that define pivot points.

[0085] The metal bracket 222 includes a top 224, a bottom 226, a first side 228, a second side 230 and end 232. The top 224 includes a contact point 234, a gusset 236 and a downwardly extending flange

238. The gusset 236 increases the strength of the metal bracket 222. The end 232 includes a rectangular opening 240 for receiving the carriage bolt 246 when the retainer bracket 202 and the metal bracket 222 are assembled. The first side 228 and the second side 230 include edges 242, 244, respectively, that define pivot points. The pivot points compress around the ladder rung 60 when the bolt 246 is tightened. As illustrated in FIG. 14, the retainer bracket 202 and the metal bracket 222 are secured together via the carriage bolt 246 and nut 248. The cradle clamp bracket assembly 200 defines an opening 250 for receiving various sized ladder rungs. The cradle clamp bracket assembly 200 also defines V-shaped notches 252 for enabling the cradle clamp bracket 200 to engage the ladder rung 60 when the cradle clamp bracket assembly 200 is installed on the ladder rung 60.

[0086] As illustrated in FIGS. 15-16, the cradle clamp bracket assembly 200 is installed on a ladder rung similar to the cradle clamp bracket assembly 100 of FIGS. 1-10. As illustrated in FIG. 15, the cradle clamp bracket assembly 200 is placed under a ladder rung 60. The nut 248 is tightened to secure the cradle clamp bracket assembly 200 to the ladder rung 60. A cushion sleeve 80 is wrapped around the cables 70. The cushion sleeve 80 and cables 70 are positioned on the top 224 of the metal bracket 222 of cradle clamp bracket assembly 200. The stainless steel tie or strap 90 is wrapped around the cushion sleeve 80 and under the cradle clamp bracket assembly 200 as illustrated in FIG. 16. A tool (not illustrated) is used to tension the tie or strap 90 to complete the installation of the cradle clamp bracket assembly 200.

[0087] FIGS. 17-24 illustrate a third embodiment of a cradle clamp bracket assembly 300. As illustrated in FIG. 19, the cradle clamp bracket assembly 300 includes a J-hook 302, a metal bracket 314 and a nut 336. The J-hook 302 includes a top 304 with a contact point 306, a center 308 with a flat member 310 and a threaded end 312. The metal bracket 314 includes a top 316 with a gusset 318 and a downwardly extending flange 320. The gusset 318 increases the strength of the metal bracket 314. The metal bracket 314 also includes a bottom 322, a first end 324, a second end 326, a first side 328 and a second side 330. The first end 324 includes a notch 332 for receiving the flat portion 310

of the J-hook 302 and the second end 326 includes an opening 334 for receiving the threaded end 312 of the J-hook 302.

[0088] As illustrated in FIGS. 20-24, the cradle clamp bracket assembly 300 is secured to the ladder rack similar to the installation of the cradle clamp bracket assembly 200 described above. The cradle clamp bracket assembly 300 is positioned under the ladder rung 60 (see FIG. 23). The nut 336 is tightened to secure the cradle clamp bracket assembly 300 to the ladder rung 60. The contact point 306 on the J-hook 302 creates a concentrated force on the ladder rung 60 when secured in place. The cushion sleeve 80, cables 70 and stainless steel tie or strap 90 are installed on the cradle clamp bracket assembly 300 and ladder rung 60 as described above with respect to the cradle clamp bracket assemblies 100, 200 illustrated in FIGS. 1-16.

[0089] FIGS. 25-36 illustrate a fourth embodiment of a cradle clamp bracket assembly 400 of the present invention installed on a rectangular ladder rung 62. The cradle clamp bracket assembly 400 includes a metal bracket 402, a retainer bracket 412, and a fastener 440, such as a bolt. The metal bracket 402 includes an elongated rectangular slot 404 for receiving the fastener 440 and retainer bracket 412. One end of the metal bracket 402 also includes a raised member 406 with a downwardly extending flange 408 for receiving the cushion sleeve 80 and stainless steel tie or strap 90.

[0090] The retainer bracket 412 includes a top 414 with a circular opening 416 for receiving the fastener 440. One end of the top wraps around to provide a reinforcing layer 418. The reinforcing layer 418 also includes a circular opening 420 aligned with the circular opening 416 of the top 414 for receiving the fastener 440. The retainer bracket 412 includes first and second outer side walls 422, 424, respectively. Each outer side wall 422, 424 wraps around and extends under the top 414 to form first and second inner side members 426, 428 spaced from the first and second outer side walls 422, 424. Each inner side member 426, 428 includes a foot 430. The foot 430 of each inner side member 426, 428 is positioned within the elongated slot 404 in the metal bracket 402 when the cradle clamp bracket 400 is assembled. One end of the retainer bracket 412 includes a plurality of teeth 432

extending from the top 414 and a flange 434 extending from each side 422, 424. The plurality of teeth 432 and each flange 434 are contact points that create a concentrated force on the ladder rung 62 when the cradle clamp bracket assembly 400 is installed.

[0091] As illustrated in FIGS. 29-31, the cradle clamp bracket assembly 400 is positioned under a ladder rung 62. The retainer bracket 412 is slid against the ladder rung 62 to lock it in place. The bolt 440, or other fastener, is tightened to secure the cradle clamp bracket assembly 400 to the ladder rung 62.

[0092] As illustrated in FIGS. 25, 26 and 32, a cushion sleeve 80 is wrapped around the cables 70 and a stainless steel tie or strap 90 is wrapped underneath the raised member 406 at the end of metal bracket 402 and cushion sleeve 80 securing the cables 70 to the ladder rung 62. A tool (not illustrated) is used to tension the tie or strap 90 thereby completing installation of the cradle clamp bracket assembly 400.

[0093] FIGS. 25-32 illustrate the cradle clamp bracket assembly 400 installed on a rectangular ladder rung 62. As illustrated in FIGS. 33-36, the cradle clamp bracket assembly 400 may also be used with various types of ladder rungs. For example, the cradle clamp bracket assembly 400 may be used with a strut rung 63 (FIGS. 33-34) or a round rung 64 (FIGS. 35-36). Alternatively, cradle clamp bracket assembly 400a may be used with ladder rungs having flanged ends. As illustrated in FIGS. 37-45, cradle clamp bracket assembly 400a includes metal bracket 402a with a raised member 406a having a flange 408a and a retainer bracket 412a. The retainer bracket 412a does not include teeth or flange contact points. Instead, contact points 434a are at the bottom of the retainer bracket 412a to accommodate the flanged end of a ladder rack 65. Cradle clamp bracket assembly 400a may be used with a top hat rung 65 (FIGS. 37-41), inside a strut rung 66 (FIGS. 42-43) or a beam rung 67 (FIGS. 44-45).

[0094] FIGS. 46-53 illustrate a fifth embodiment of a cradle clamp bracket assembly 500 of the present invention. As illustrated in the exploded view of FIG. 48, the cradle clamp bracket assembly 500 includes a slotted bracket 502, a retainer bracket 520, a bolt 540 and a nut 542. The slotted bracket

502 includes an elongated slot 504 that extends the length of the bracket 502 and retainer clip slots 506 that intersect the elongated slot 504. The retainer clip slots 506 enable the cradle clamp bracket assembly 500 to be used with a range of ladder rung widths.

[0095] The slotted bracket 502 includes a raised member 510 with at least one gusset 512. The slotted bracket also includes a flange 514 extending downwardly from the raised member 510.

[0096] The retainer bracket 520 is L-shaped with a vertical member 522 and a horizontal member 526. The vertical member 522 includes a foot or projection 524 that is positioned within one of the retainer clip slots 506 of the slotted bracket 502. The horizontal member 526 includes an opening 528 for receiving the bolt 540 and a plurality of sharp contact points 530 that secure the bracket assembly 500 to the ladder rung 66 when the nut 542 is tightened, as described below with respect to FIGS. 49-53.

[0097] To install the cradle clamp bracket assembly 500, the retainer bracket 520 is placed in one of the retainer clip slots 506 of the slotted bracket 502. More specifically, the foot or projection 524 of the retainer bracket 520 is positioned in one of the retainer clip slots 506. The retainer bracket 520 is positioned in the slot 506 that provides the best untightened fit with the ladder rung 66 to be secured. A carriage bolt 540 is placed in the opening 528 of the retainer bracket 520 and then through the elongated slot 504 of the slotted bracket 502. The nut 542 is then installed on the carriage bolt 540.

[0098] The cradle clamp bracket assembly 500 is placed under a ladder rung 66 and the nut 542 is tightened to secure the cradle clamp bracket assembly 500 to the ladder rung 66. As illustrated in FIGS. 51-53, when the nut 542 is tightened, the retainer bracket 520 is forced against the ladder rung 66. As described above, to use the cradle clamp bracket assembly 500 to secure cables to the ladder rung 66, cables would be positioned on the ladder rung and a cushion sleeve would be wrapped around the cables. A stainless steel tie or strap would be wrapped around the cables and under the slotted bracket. A tool would be used to tension the tie or strap to complete installation of the cradle clamp bracket assembly 500.

[0099] As discussed above, with respect to FIGS. 37-45, the cradle clamp bracket assembly may also be used with ladder rungs having flanged ends. For example, FIGS. 52A and 53A illustrate the cradle clamp bracket assembly 500a secured to a top hat rung 65 and FIGS. 52B and 53B illustrate the cradle clamp bracket assembly 500b secured to a beam rung 67.

[00100] FIGS. 54-63 illustrate a sixth embodiment of a cradle clamp bracket assembly 600 of the present invention. The cradle clamp bracket assembly 600 includes a slotted bracket 602, a retainer bracket 620, a spacer 632, a bolt 640 and a nut 642. The slotted bracket 602 includes an elongated slot 604 that extends the length of the bracket 602 and retainer clip slots 606 that intersect the elongated slot 604. The retainer clip slots 606 enable the cradle clamp bracket assembly 600 to be used with a range of ladder rung widths. The slotted bracket 602 also includes downwardly extending ribs 608 for providing additional strength to the bracket 602.

[00101] The slotted bracket 602 includes a raised member 610 with at least one gusset 612. The slotted bracket 602 also includes a flange 614 extending downwardly from the raised member 610.

[00102] The retainer bracket 620 is L-shaped with a vertical member 622 and a horizontal member 626. The vertical member 622 includes a foot or projection 624 that is positioned within one of the retainer clip slots 606 of the slotted bracket 602. The horizontal member 626 includes an opening 628 for receiving the bolt 640 and a plurality of sharp contact points 630 that secure the bracket assembly 600 to the ladder rung when the nut 642 is tightened, as described below with respect to FIGS. 58-63.

[00103] As illustrated in FIGS. 58-63, the retainer bracket 620 is designed to engage the ladder rung 62 at an angle to increase the retention strength of the cradle clamp bracket assembly 600 to the ladder rung 62. The cradle clamp bracket assembly 600 further includes a spacer 632. The spacer 632 creates a positive stop that will prevent the installer from over tightening the bolt 640.

[00104] To install the cradle clamp bracket assembly 600, the foot or projection 624 of the retainer bracket 620 is positioned in one of the retainer clip slots 606. The retainer bracket 620 is positioned in the slot 606 that provides the best untightened fit with the ladder rung 62 to be secured. A

carriage bolt 640 is placed in the opening 628 of the retainer bracket 620 and then through the elongated slot 604 of the slotted bracket 602. The nut 642 is then installed on the carriage bolt 640.

[00105] The cradle clamp bracket assembly 600 is placed under a ladder rung 62 and the nut 642 is tightened to secure the cradle clamp bracket assembly 600 to the ladder rung 62. As illustrated in FIGS. 58-63, when the nut 642 is tightened, the retainer bracket 620 is forced against the ladder rung 62. As described above, to use the cradle clamp bracket assembly 600 to secure cables to the ladder rung 62, cables would be positioned on the ladder rung and a cushion sleeve would be wrapped around the cables. A stainless steel tie or strap would be wrapped around the cables and under the slotted bracket. A tool would be used to tension the tie or strap to complete installation of the cradle clamp bracket assembly 600.

[00106] FIGS. 64-71 illustrate a seventh embodiment of a cradle clamp bracket assembly 700 of the present invention. The cradle clamp bracket assembly 700 is designed to engage the flanges of a strut ladder rung and sandwich the flanges between a bracket and a ladder rung nut of the cradle clamp bracket assembly 700.

[00107] The cradle clamp bracket assembly 700 includes a bracket 702, a screw 720, a compression spring 722 and a ladder rung nut 724. The ladder rung nut 724 includes a threaded hole 726 and curved surfaces 728. The bracket 702 includes a T-shaped slot 704, a recessed area 706 with a slot 708, a raised member 710 with gussets 712, and a flange 714 extending downwardly from the raised member 710.

[00108] The recessed area 706 and slot 708 accommodate the screw 720, the compression spring 722 and the ladder rung nut 724. The compression spring 722 keeps the screw 720 and ladder rung nut 724 upright for easier installation when the bracket 702 is installed onto the ladder rung 66. The recessed area 706 allows the fully compressed height of the spring 722 to sit recessed thereby allowing the ladder rung nut 724 to seat on various ladder rungs. The slot 708 enables the screw 720 and the

ladder rung nut 724 to be centered thereby enabling the bracket assembly to be secured to a range of ladder rung widths found on the market.

[00109] FIGS. 67-71 illustrate the installation of the cable clamp bracket assembly 700. As illustrated in FIG. 67, the screw 720 and ladder rung nut 724 installed in the bracket 702 are positioned under a ladder rung 66. The ladder rung nut 724 will rotate along with the screw 720 until the curved surfaces 728 of the ladder rung nut 724 engage with the inner walls of the ladder rung 66. As the screw 720 is tightened the ladder rung nut 724 clamps onto the flanges 68 of the ladder rung 66.

[00110] As described above, to use the cradle clamp bracket assembly 700 to secure cables to the ladder rung 66, cables would be positioned on the ladder rung and a cushion sleeve would be wrapped around the cables. A stainless steel tie or strap would be wrapped around the cables and under the slotted bracket. A tool would be used to tension the tie or strap to complete installation of the cradle clamp bracket assembly 700.

[00111] The cradle clamp bracket assemblies of the present invention are designed to be used with multiple cable sizes and a variety of ladder rack and cable tray styles. The contact points on the brackets create a concentrated force when locked which is critical for short circuit applications. The cushion sleeve provides resistance to cable movement and protects cables from damage. The cradle clamp bracket assemblies of the present invention also have a reduced installation time as the bracket assemblies only require a single common tool for installation. The cradle clamp bracket assemblies provide a significant cost advantage over conventional cable cleats by reducing material costs and increasing labor efficiency.

[00112] Furthermore, while the particular preferred embodiments of the present invention have been shown and described, it will be obvious to those skilled in the art that changes and modifications may be made without departing from the teaching of the invention. The matter set forth in the foregoing description and accompanying drawings is offered by way of illustration only and not as limitation.

The embodiments of the invention in which an exclusive property or privilege is claimed are defined as follows:

1. A cradle clamp bracket and ladder rack assembly comprising:
 - a ladder rung;
 - the bracket being elongated and having a first portion, a middle portion, a raised second portion parallel to the first portion, and a flange extending downwardly from the raised second portion, wherein the first portion receives the ladder rung, the ladder rung adapted to receive at least one cable;
 - wherein the first portion having a slot located along a center of the first portion;
 - wherein the second portion having at least one gusset for strengthening the bracket, the second portion adapted to support the at least one cable and to receive a tie to secure the at least one cable to the second portion of the bracket; and
 - a retainer received in the slot, wherein the retainer engages the ladder rung received on the first portion.
2. The cradle clamp bracket and ladder rack assembly of claim 1, wherein the retainer having a vertical member and a horizontal member.
3. The cradle clamp bracket and ladder rack assembly of claim 1, wherein the retainer having curved outer surfaces and a threaded hole therethrough.
4. A cradle clamp bracket and ladder rack assembly comprising:
 - a ladder rung;
 - the bracket having an elongated slot and a raised member; wherein the elongated slot extends a length of the bracket at a center of the bracket;
 - a retainer bracket having a vertical member positioned in the elongated slot and a horizontal member with an opening therethrough; and
 - a fastener extending through the opening in the horizontal member of the retainer bracket,

the ladder rung is positioned on the bracket between the retainer bracket and the raised member, as the fastener is tightened the horizontal member of the retainer bracket engages the ladder rung to secure the cradle clamp bracket,

whereby at least one cable is positioned on the ladder rung and the bracket, the raised member supports the at least one cable and a tie secures the at least one cable to the raised member of the bracket.

5. The cradle clamp bracket and ladder rack assembly of claim 4, wherein the bracket further comprising a plurality of retainer clip slots intersecting the elongated slot for enabling the cradle clamp bracket to be used with ladder racks having various widths.
6. The cradle clamp bracket and ladder rack assembly of claim 5, wherein the vertical member having a foot that is positioned within one of the retainer clip slots.
7. The cradle clamp bracket and ladder rack assembly of claim 4, wherein the raised member having at least one gusset for strengthening the bracket.
8. The cradle clamp bracket and ladder rack assembly of claim 4, wherein the bracket further comprising a flange extending downwardly from the raised member.
9. The cradle clamp bracket and ladder rack assembly of claim 4, wherein the retainer bracket having a plurality of contact points for engaging the ladder rung to secure the cradle clamp bracket.
10. A cradle clamp bracket and ladder rack assembly comprising:
 - a ladder rung;
 - at least one cable;
 - an elongated bracket having a first portion, a middle portion, a raised second portion parallel to the first portion, wherein the first portion receives the ladder rung and the ladder rung receives the at least one cable;
 - wherein the first portion having a slot located along a center of the first portion;

wherein the second portion having at least one gusset for strengthening the bracket, the second portion supports the at least one cable and receives a tie to secure the at least one cable to the second portion of the bracket; and

a retainer received in the slot, wherein the retainer engages the ladder rung received on the first portion.

11. The cradle clamp bracket and ladder rack assembly of claim 10, wherein the retainer having a vertical member and a horizontal member.

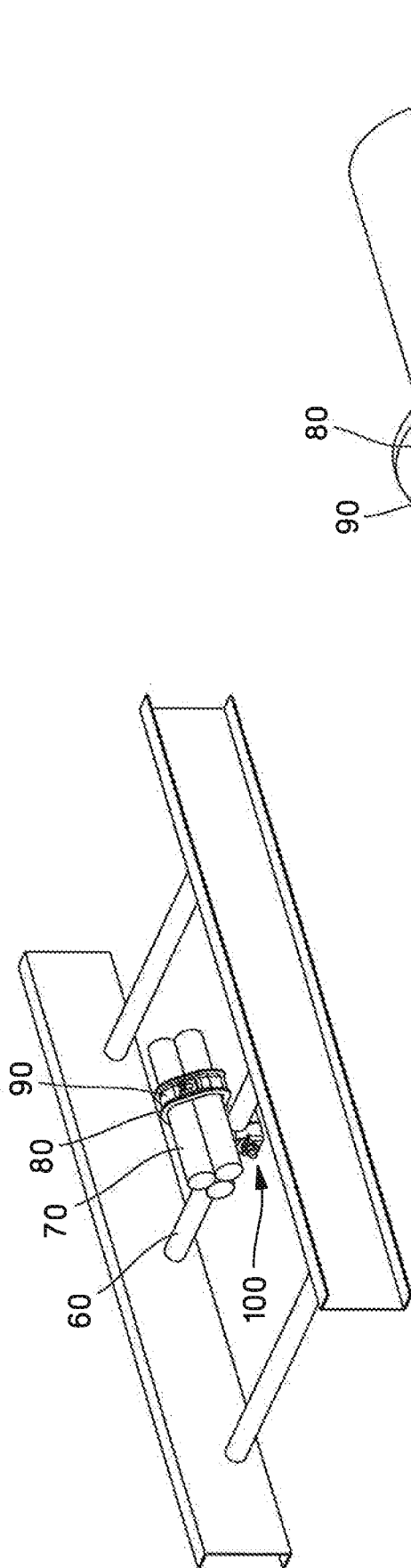

FIG. 1

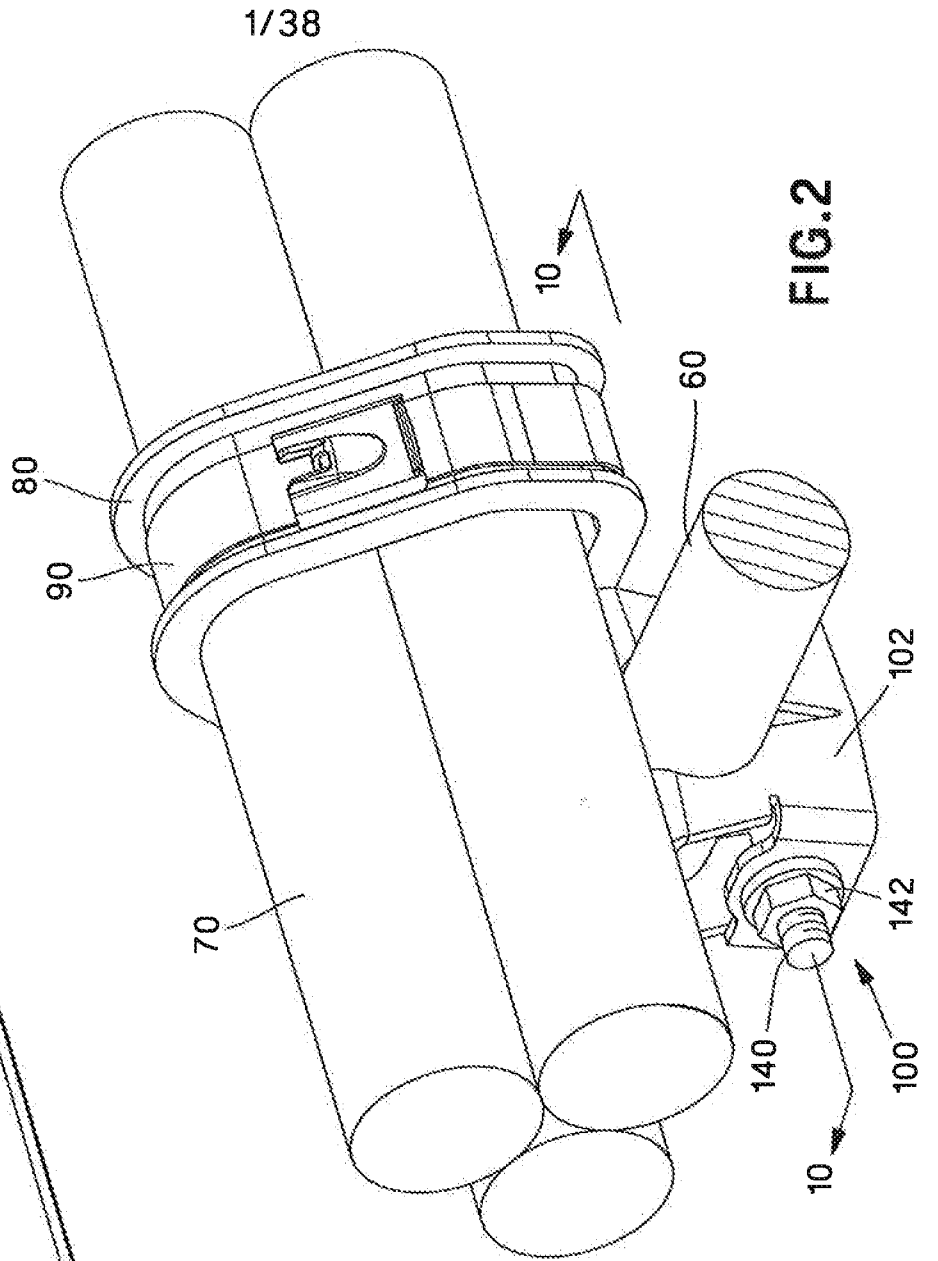

FIG. 2

1/38

10

80

90

70

60

102

142

140

100

10

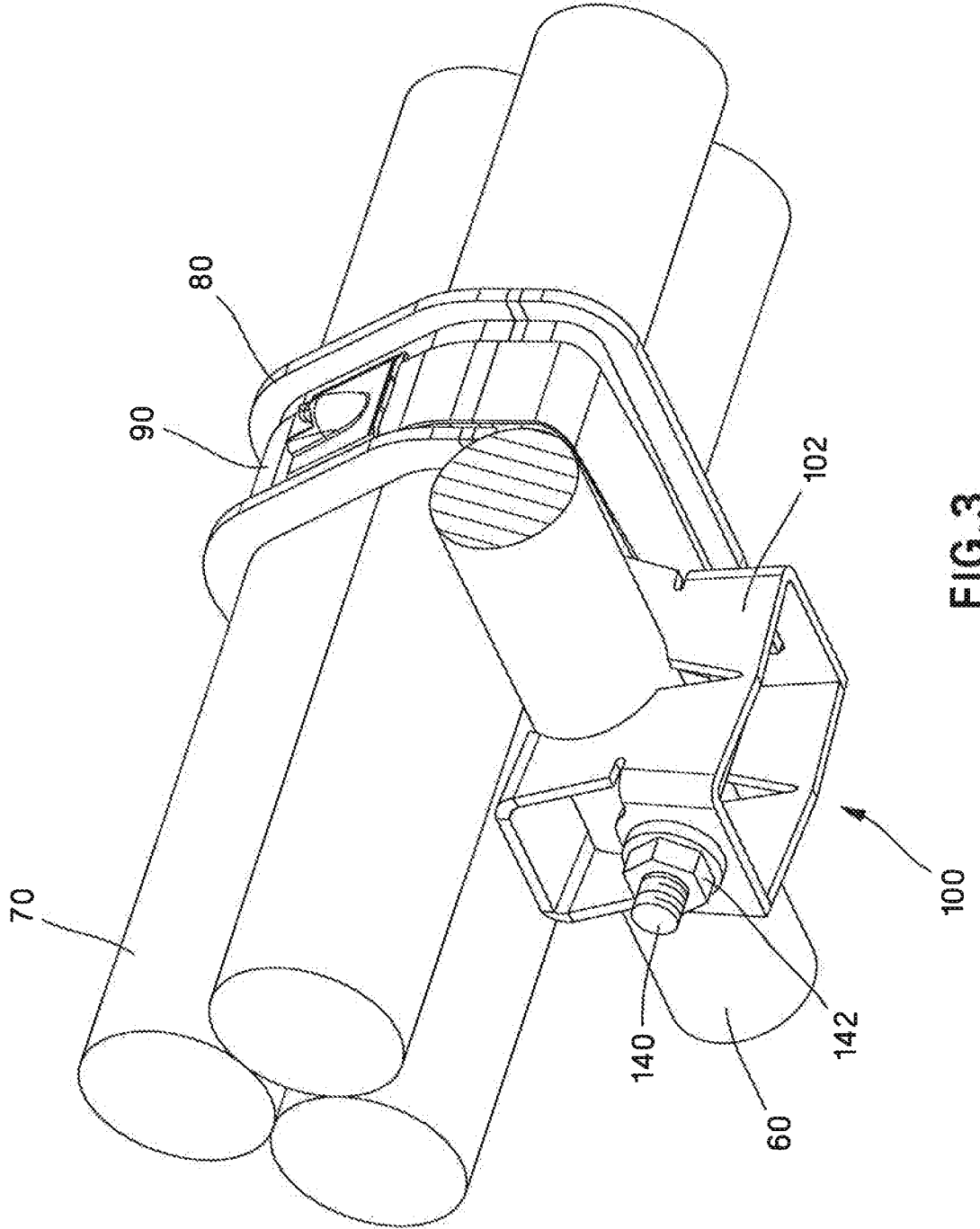

FIG. 3

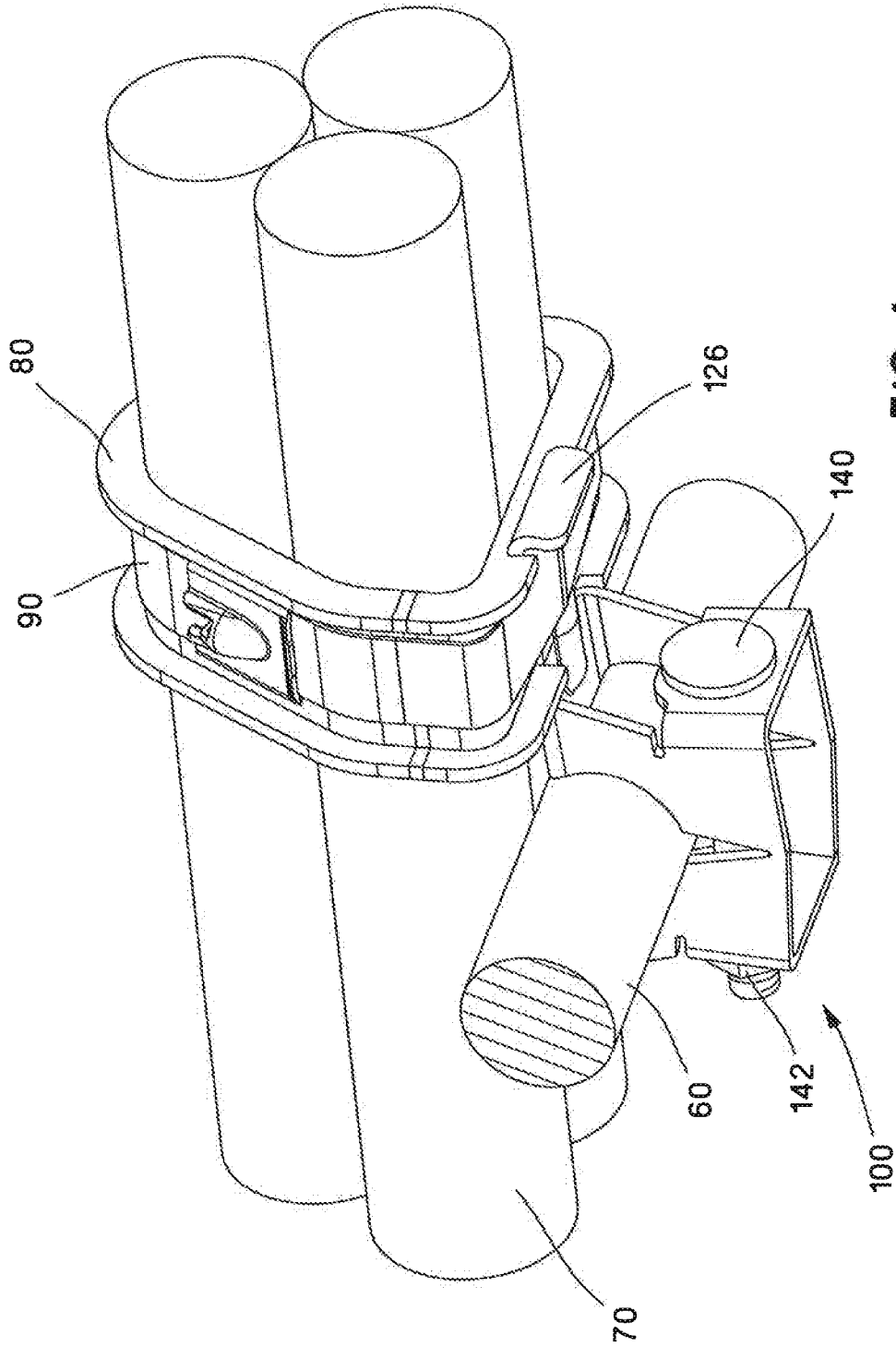
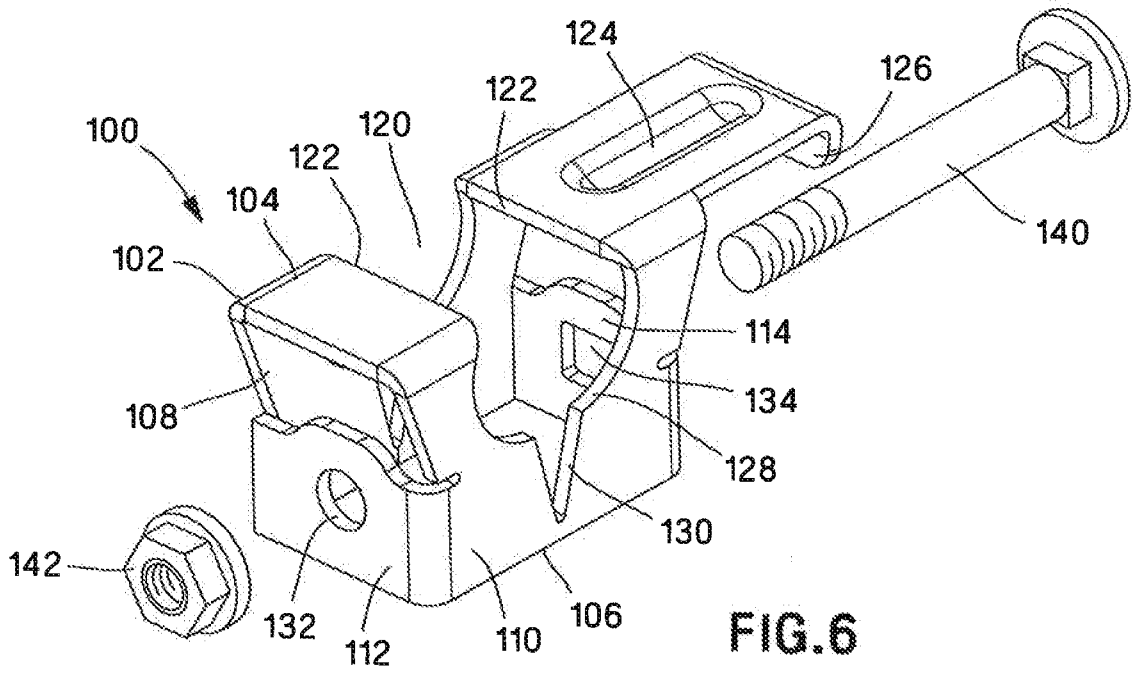
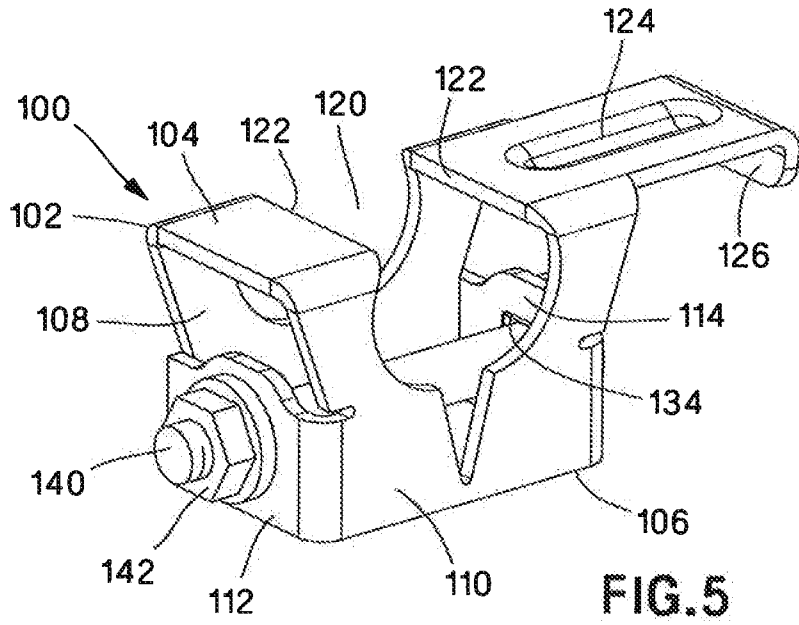

FIG. 4



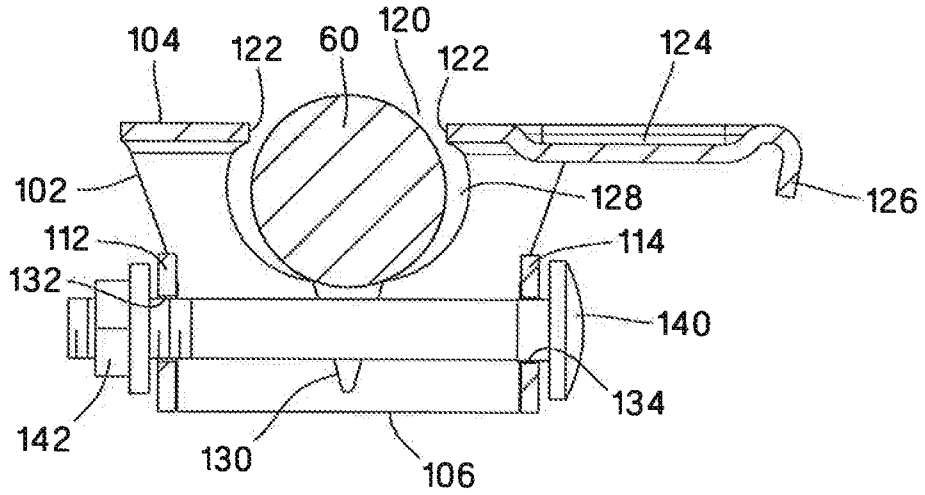

FIG. 7

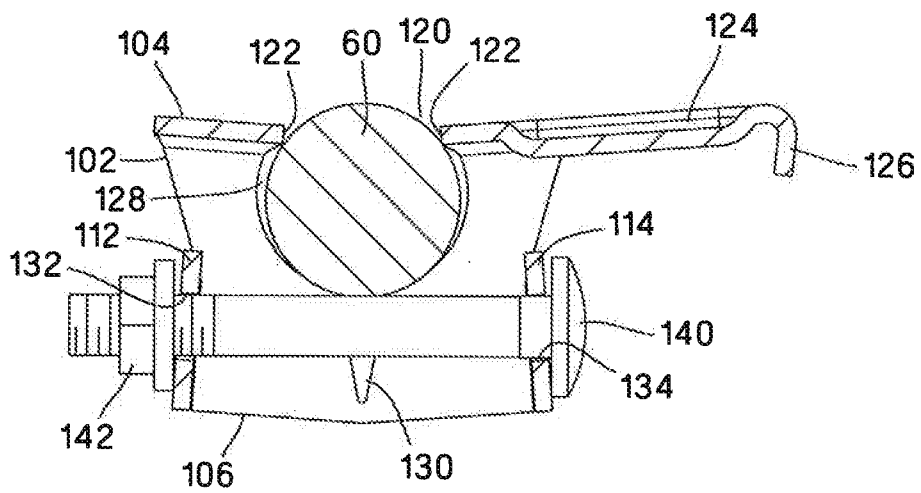

FIG. 8

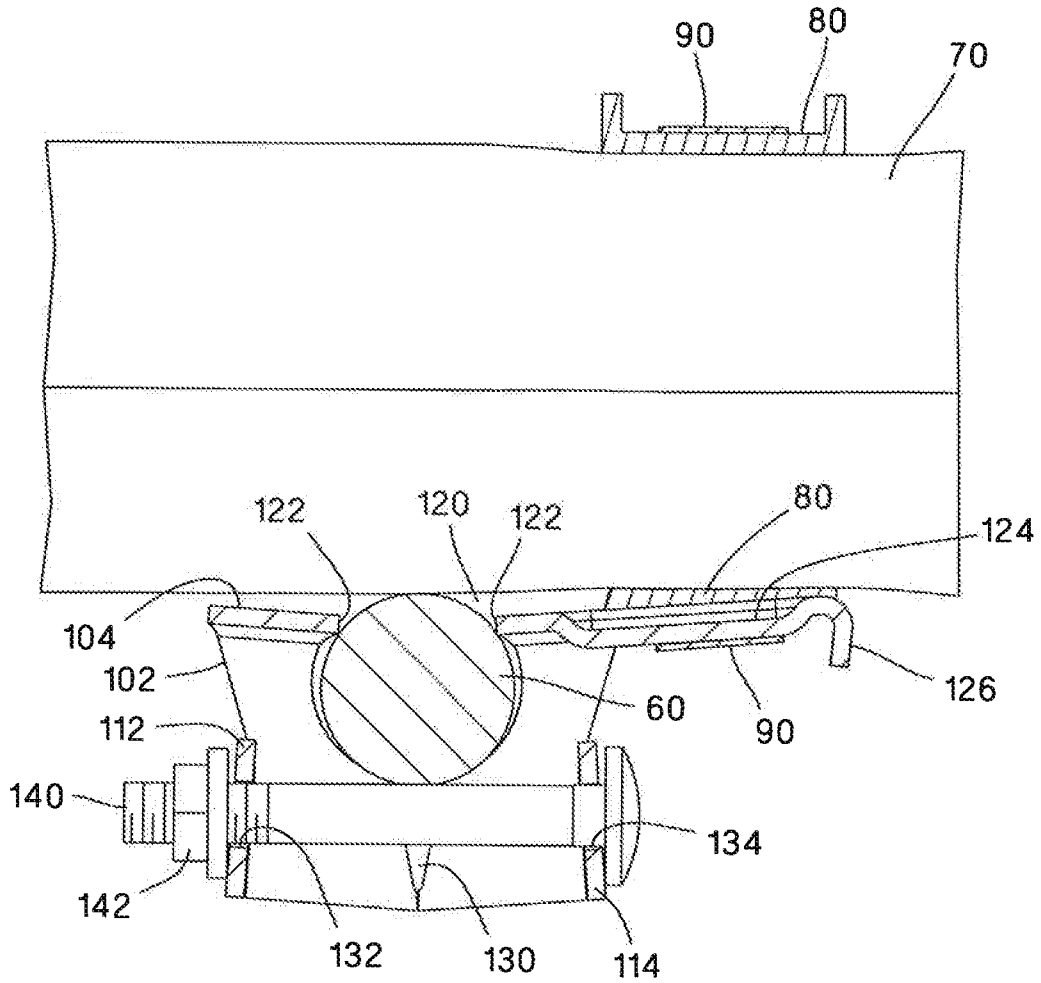

FIG. 10

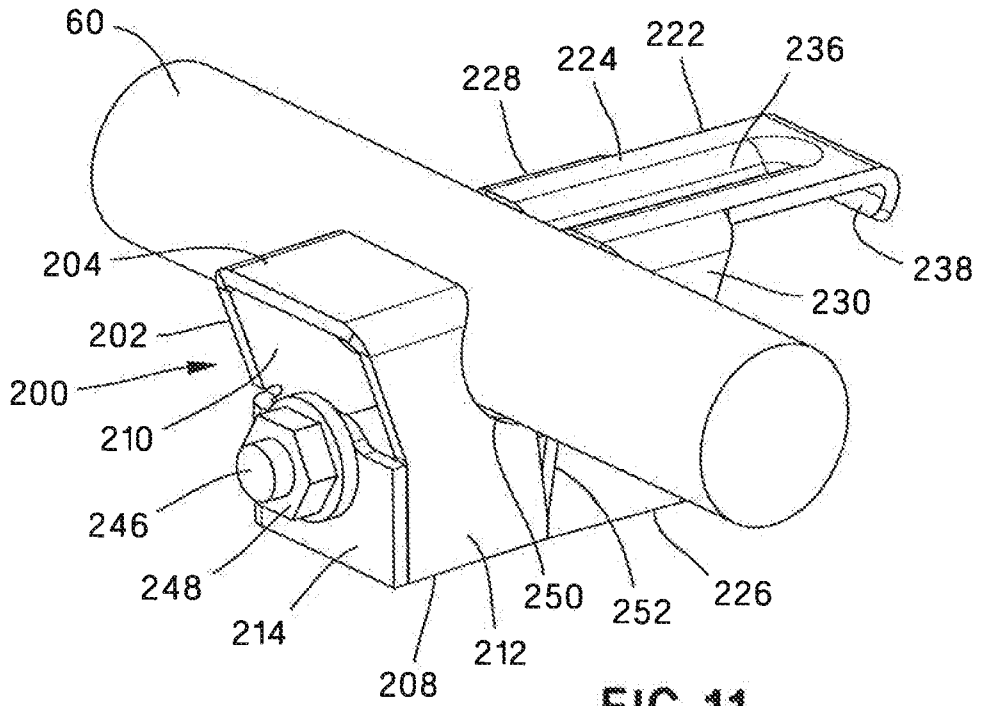

FIG. 11

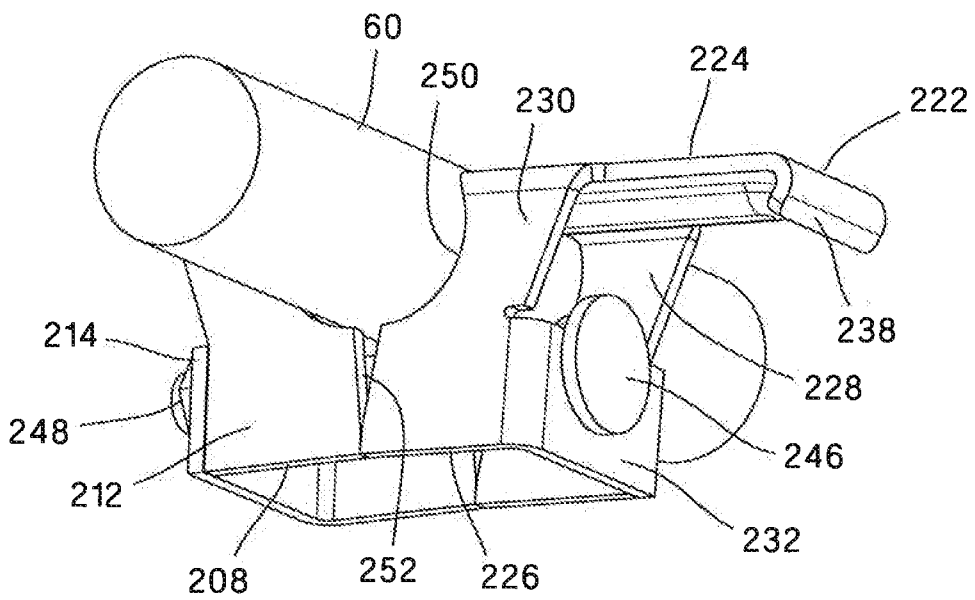

FIG. 12

10/38

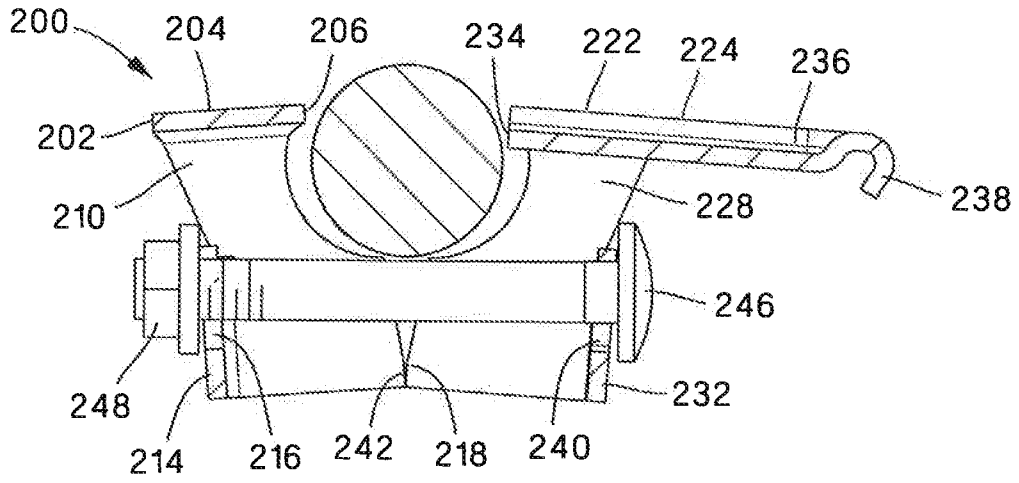

FIG. 15

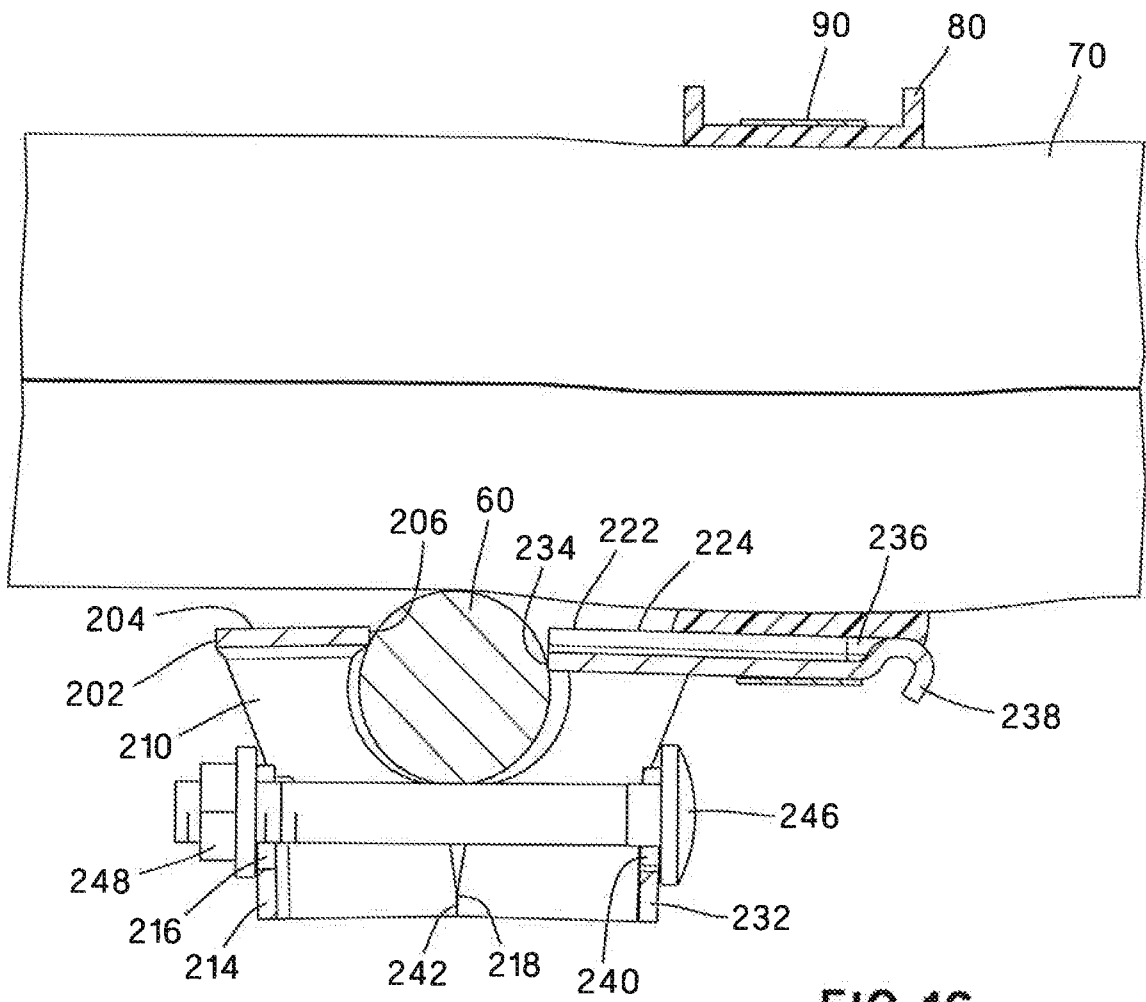
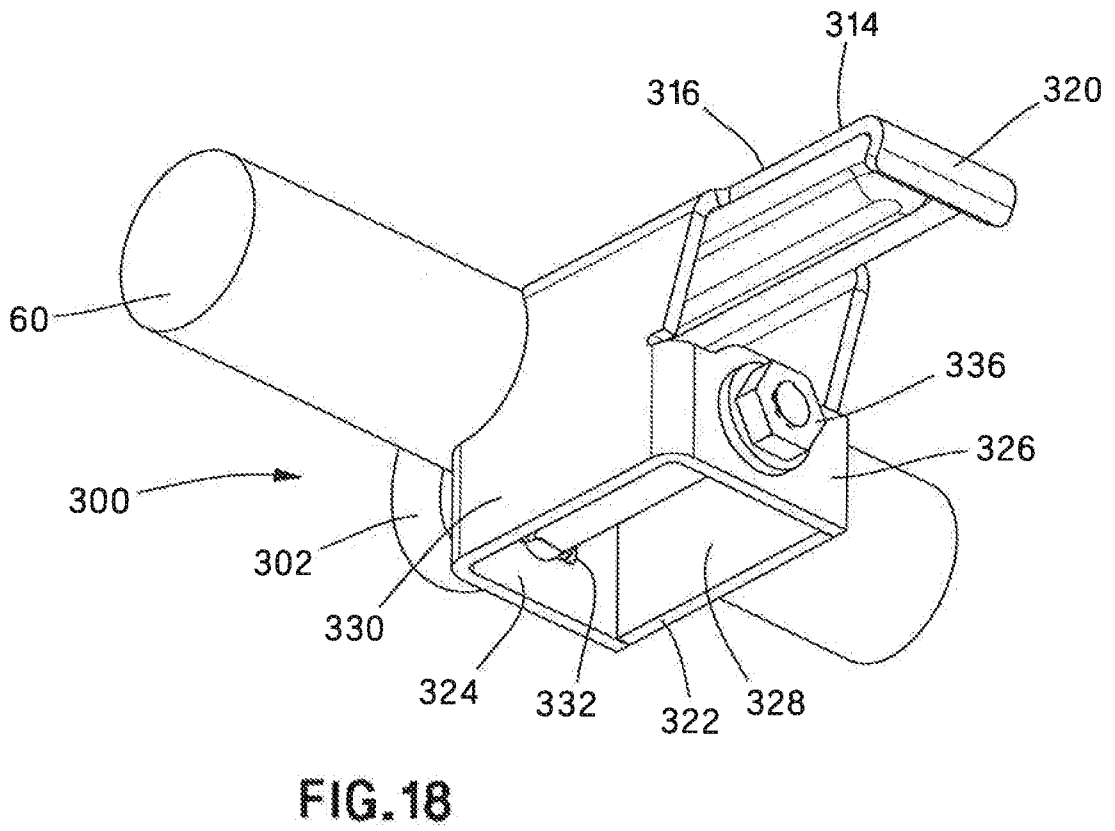
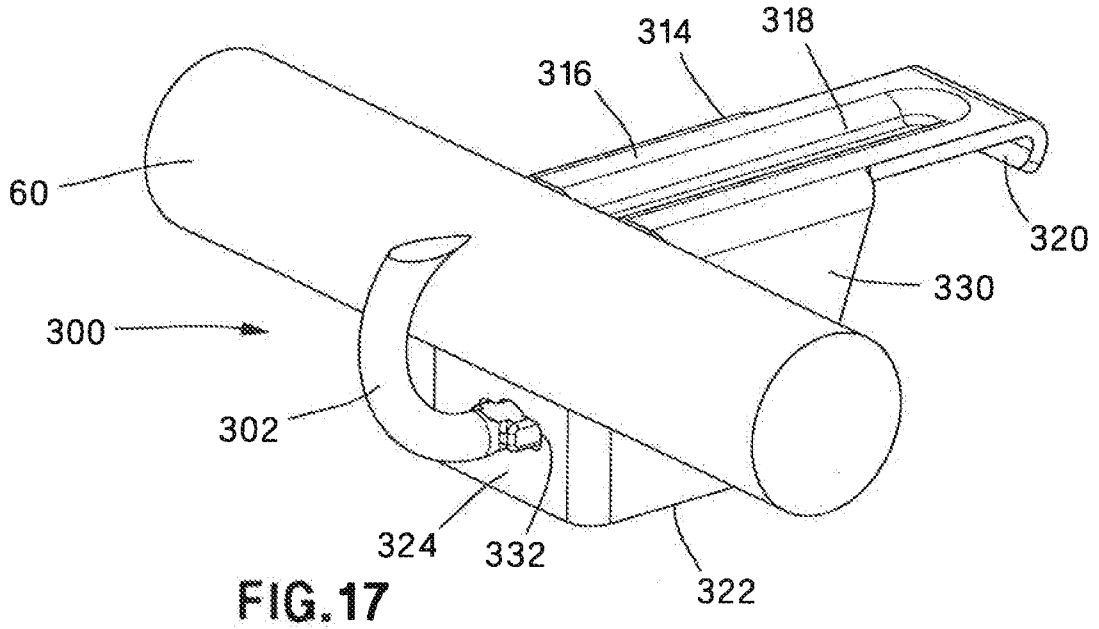

FIG. 16

11/38



12/38

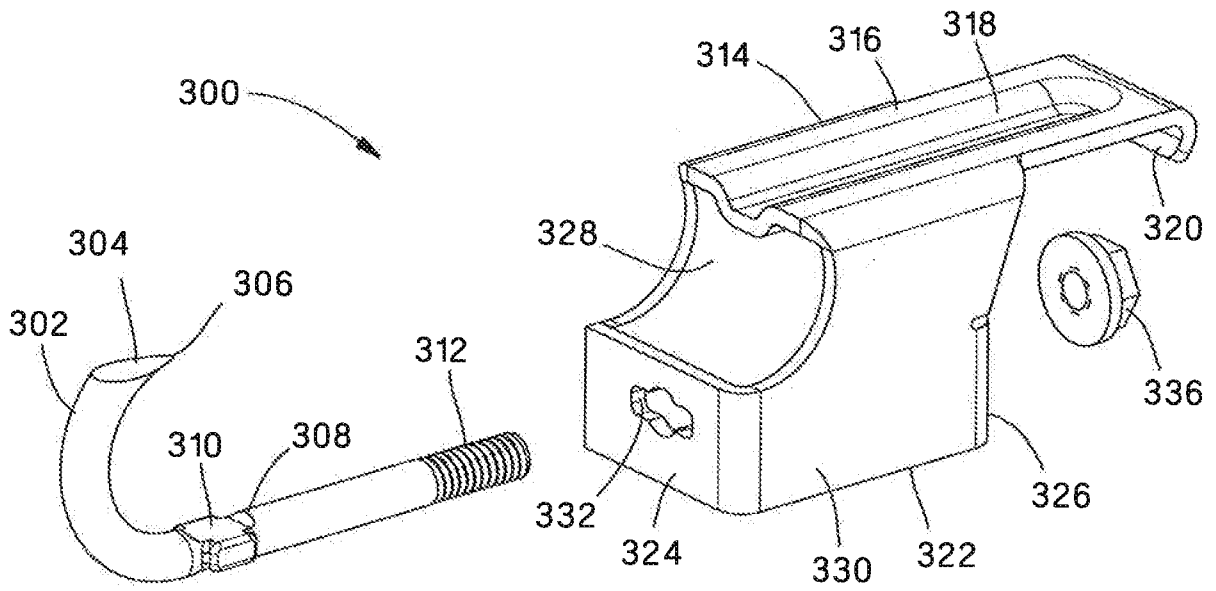

FIG. 19

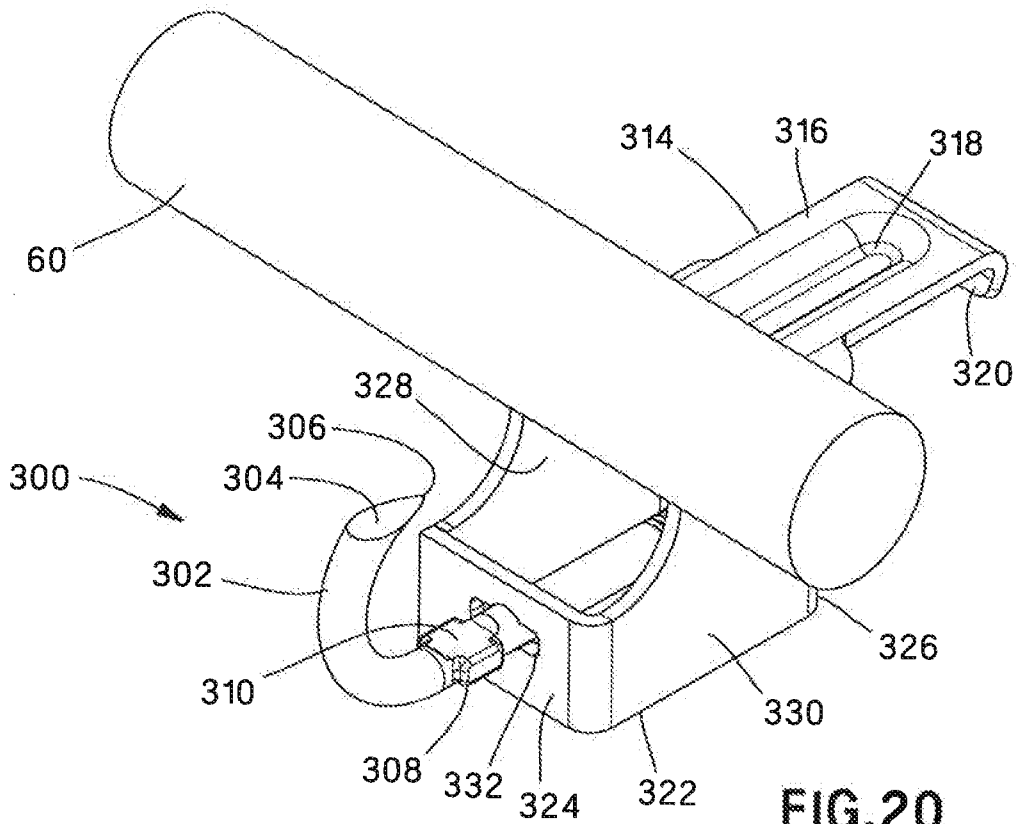

FIG. 20

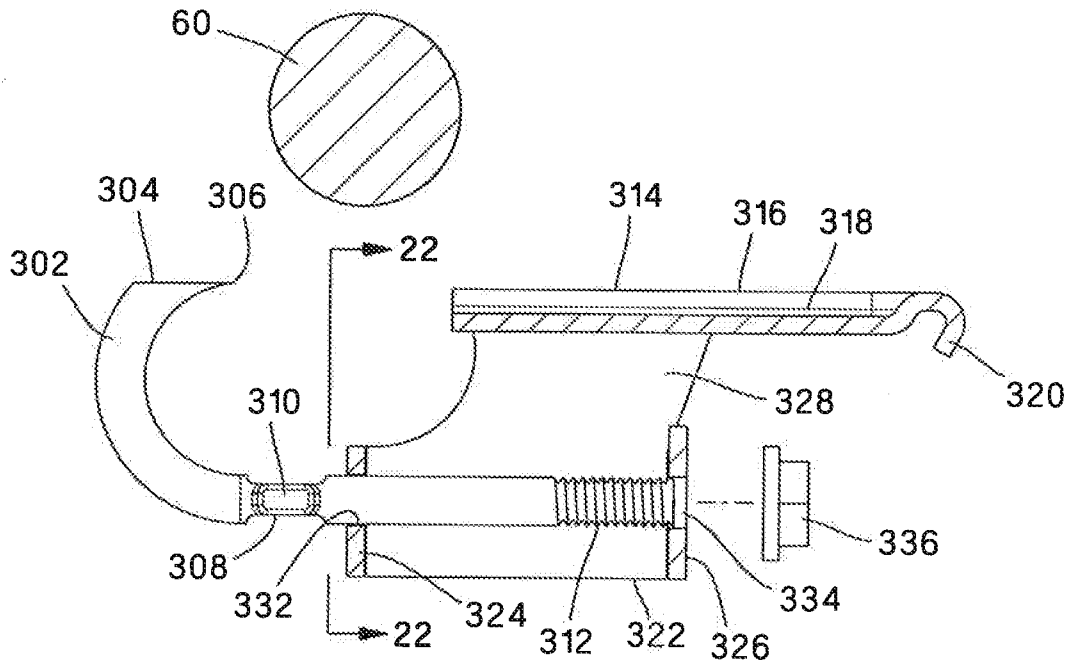

FIG. 21

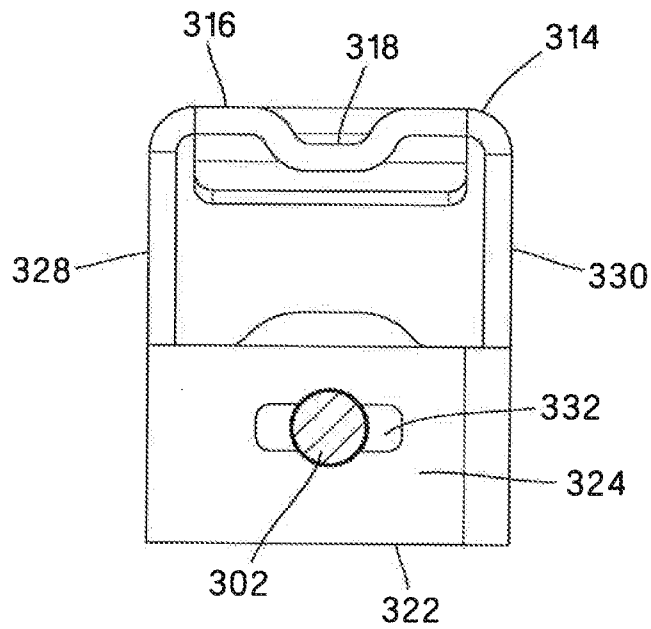

FIG. 22

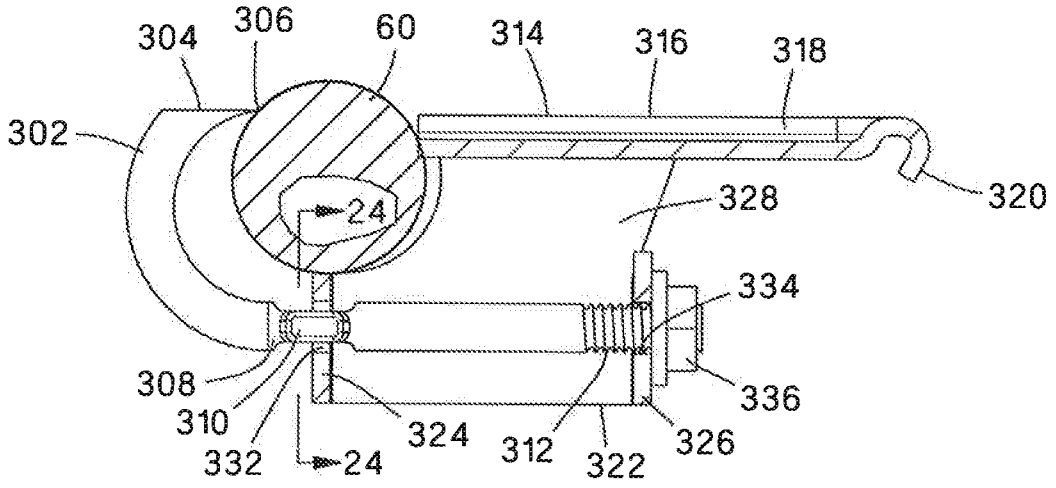

FIG. 23

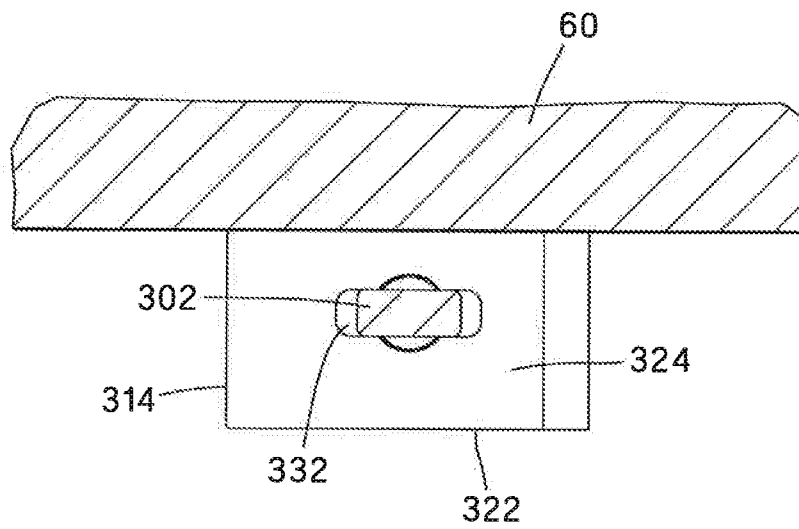

FIG. 24

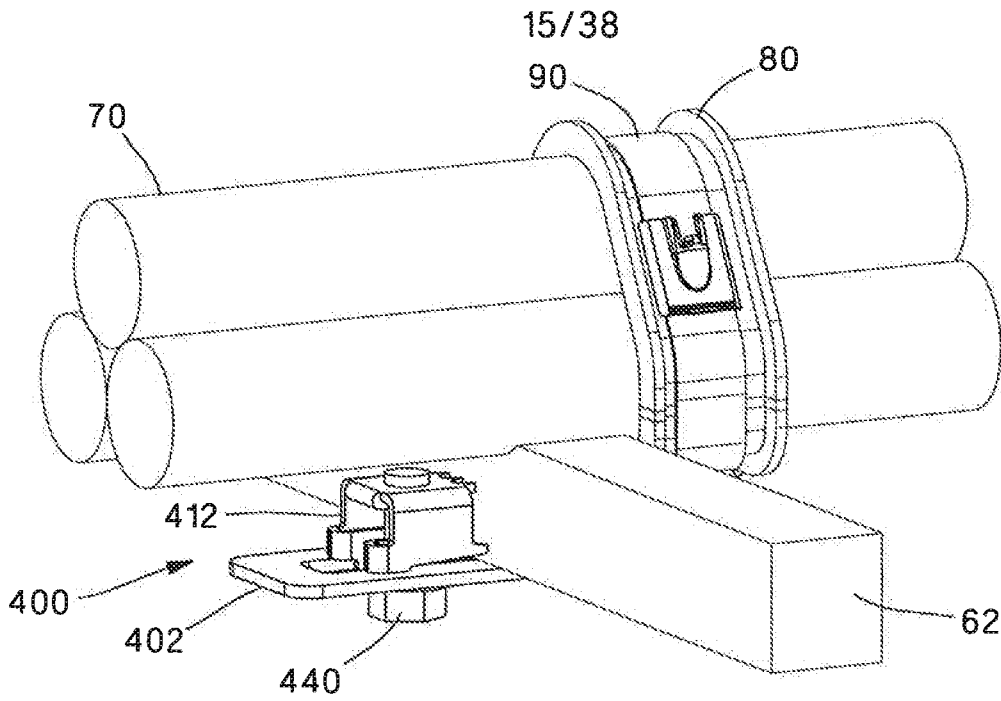

FIG. 25

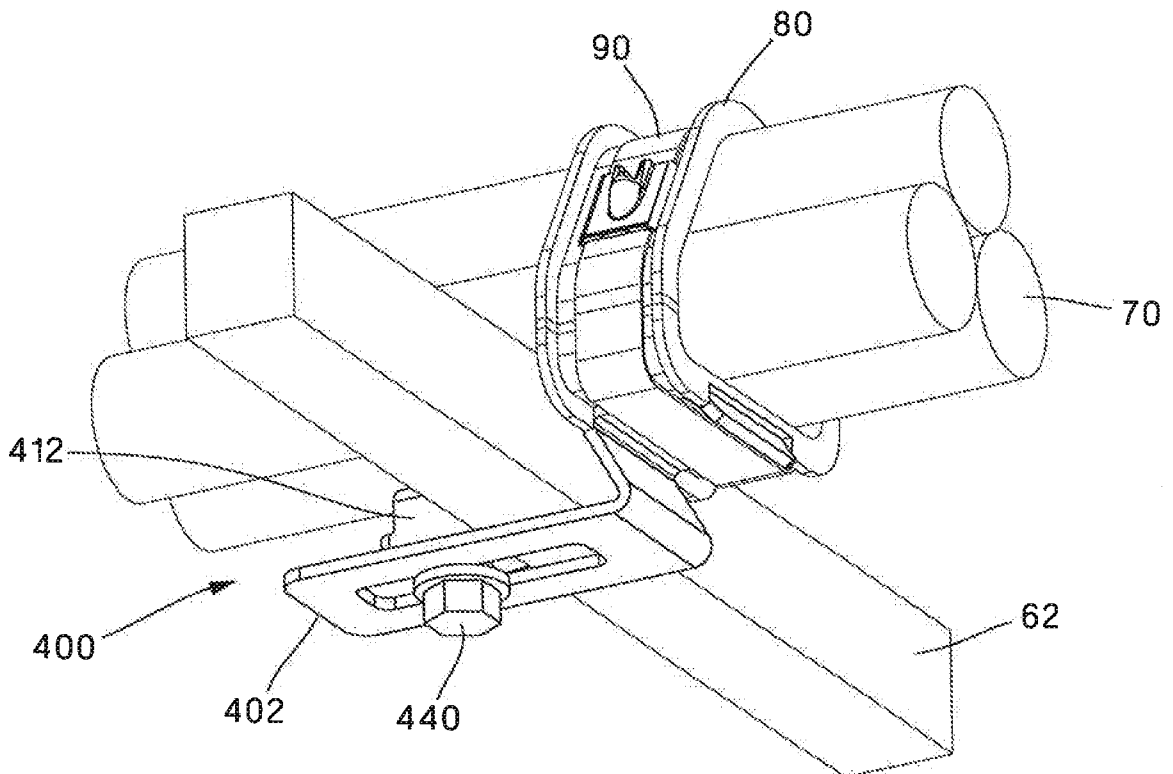

FIG. 26

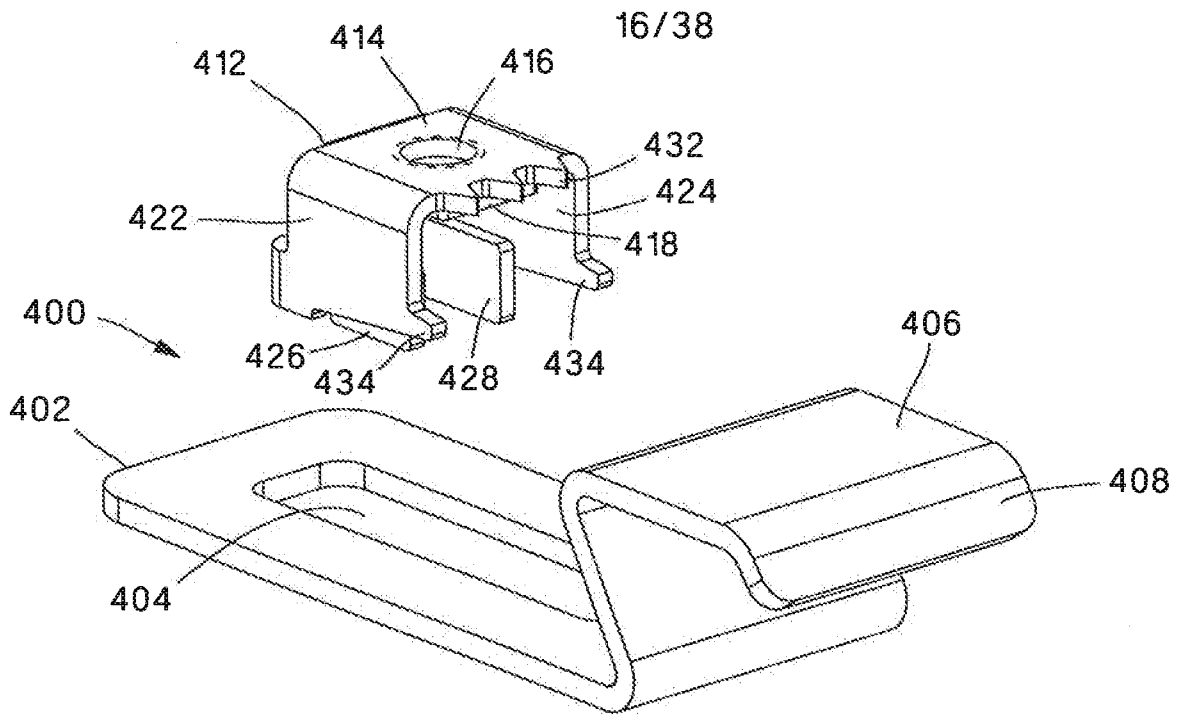

FIG.27

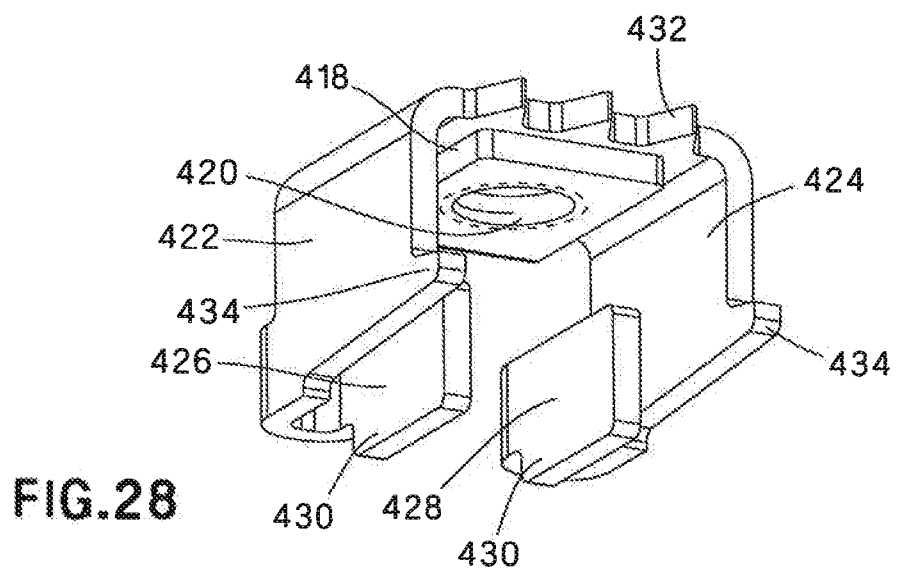

FIG.28

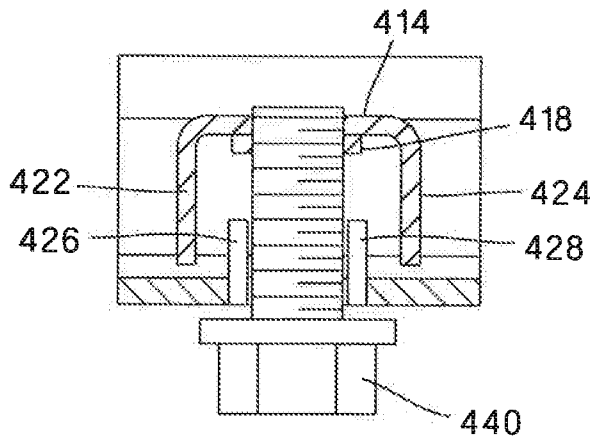
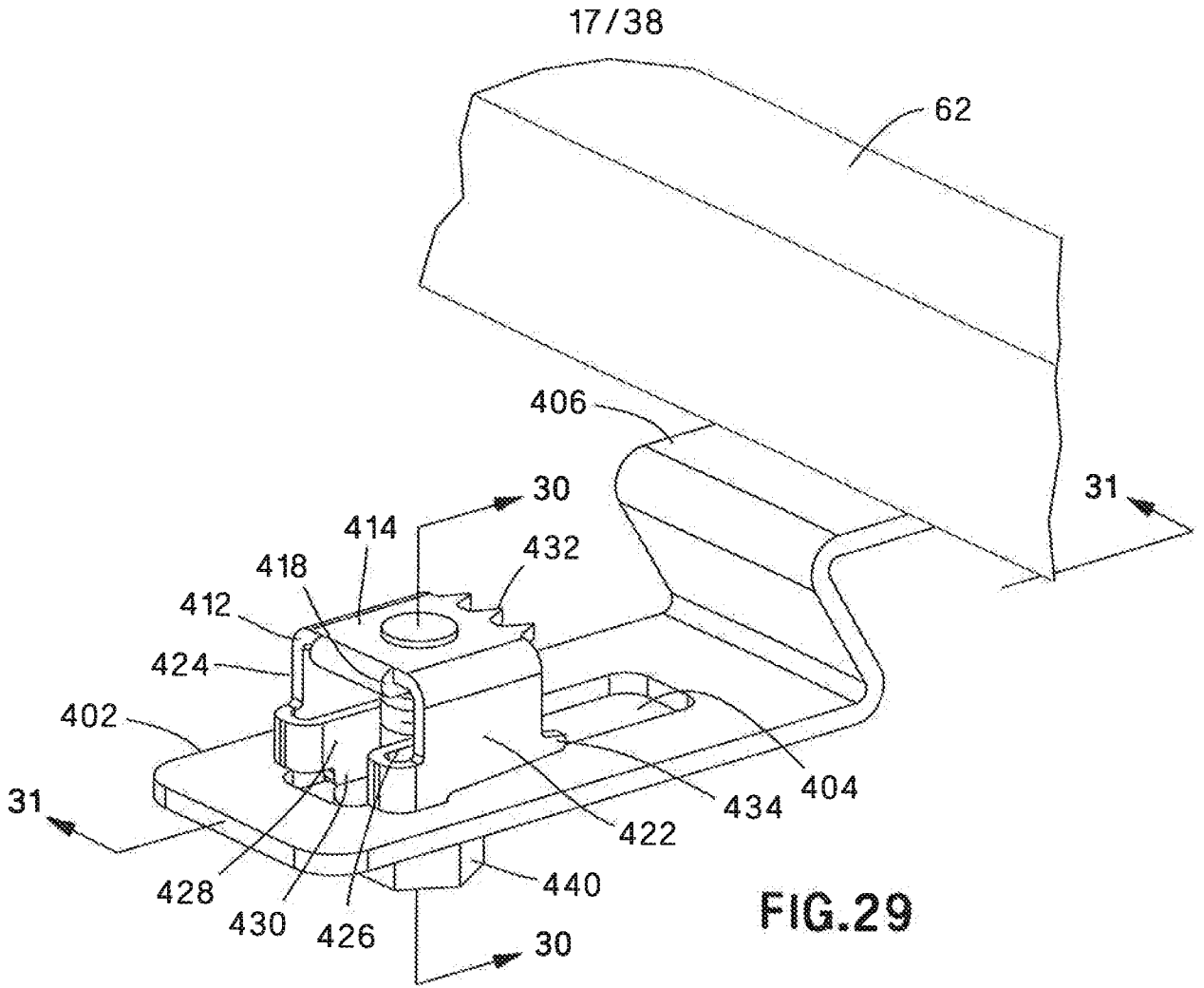

FIG. 30

18/38

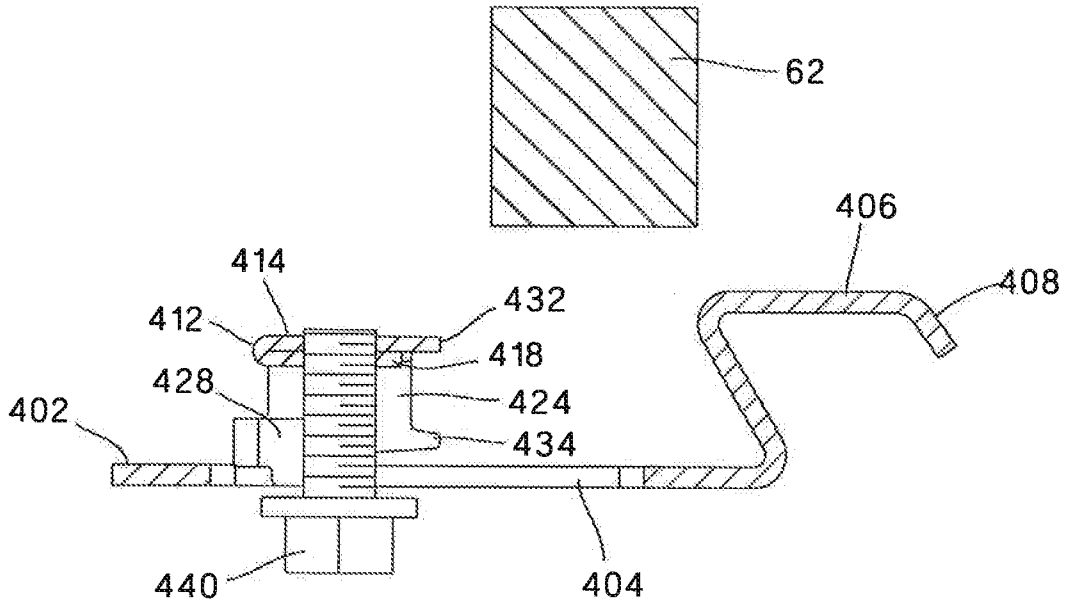

FIG. 31

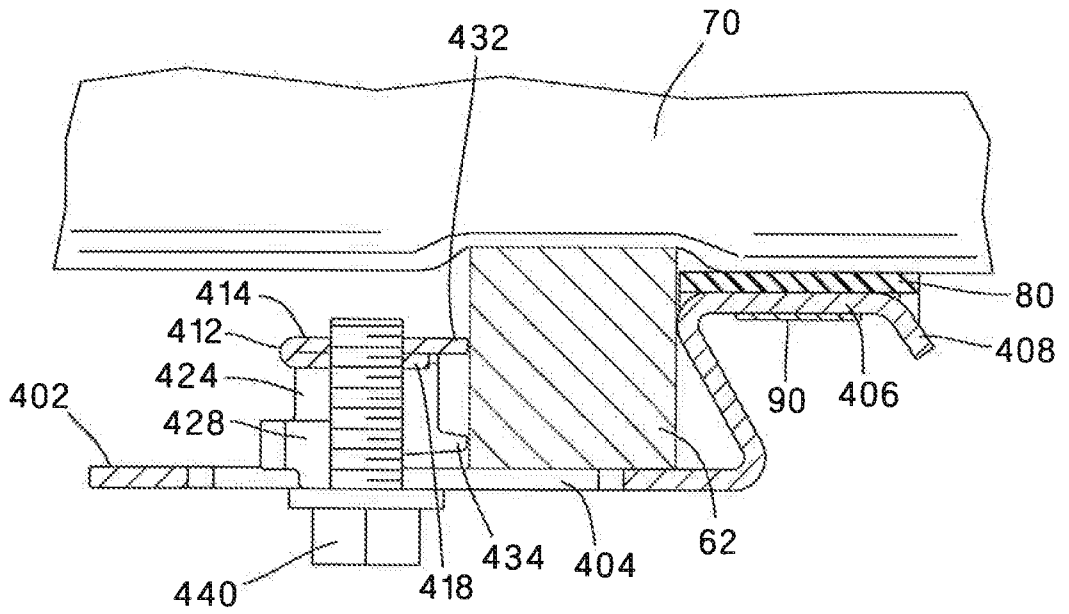

FIG. 32

19/38

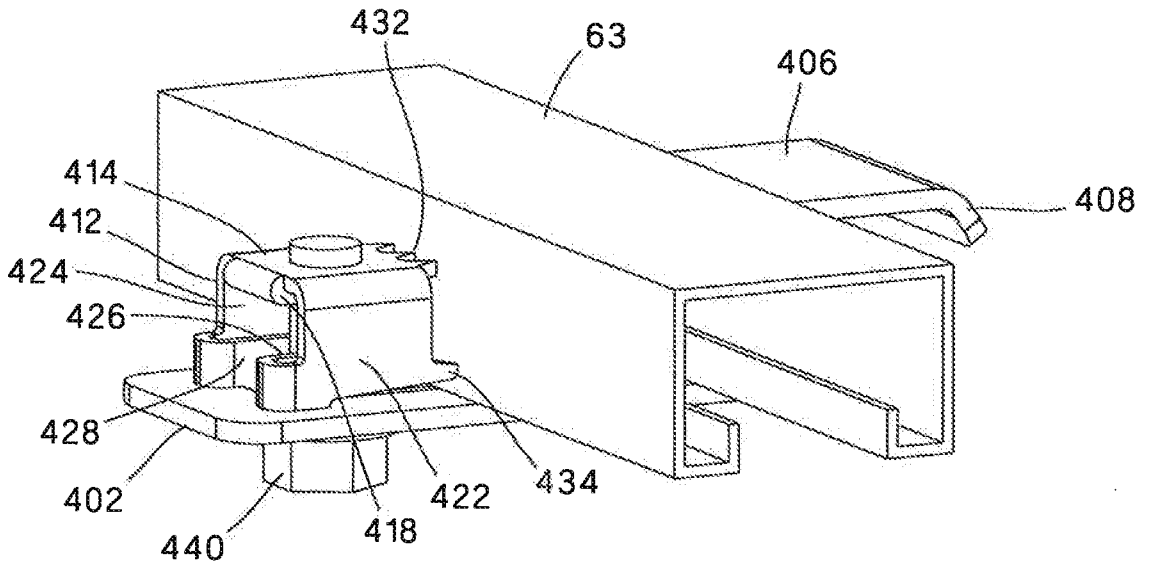

FIG. 33

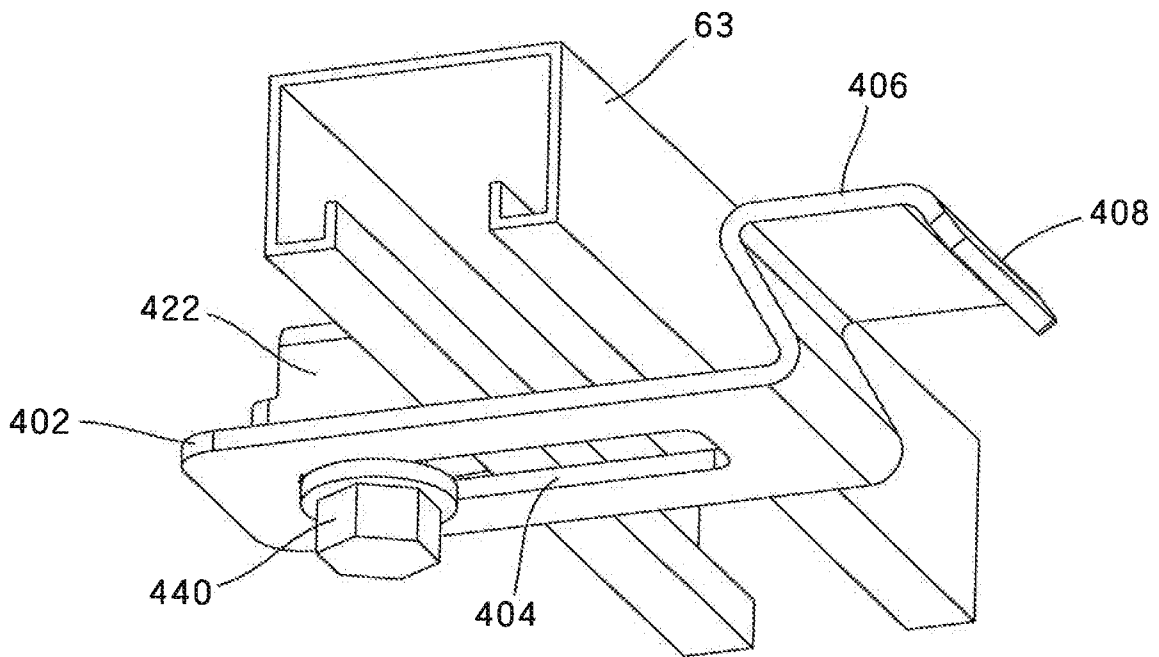

FIG. 34

20/38

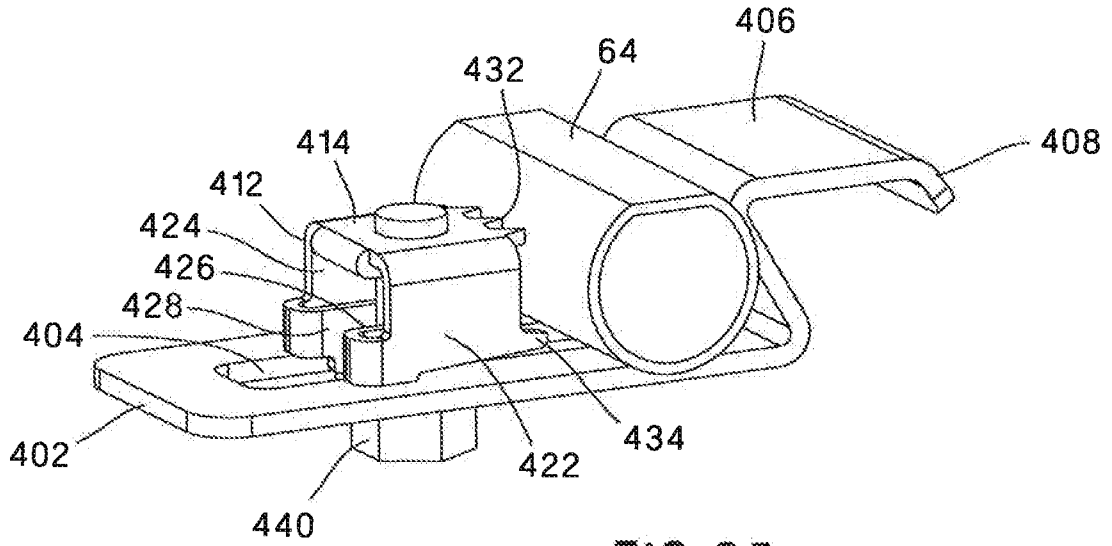

FIG.35

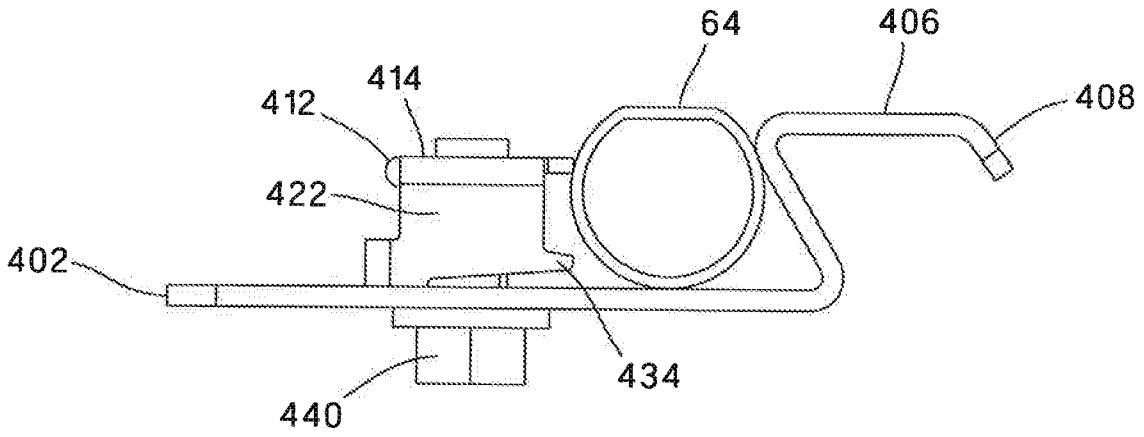

FIG.36

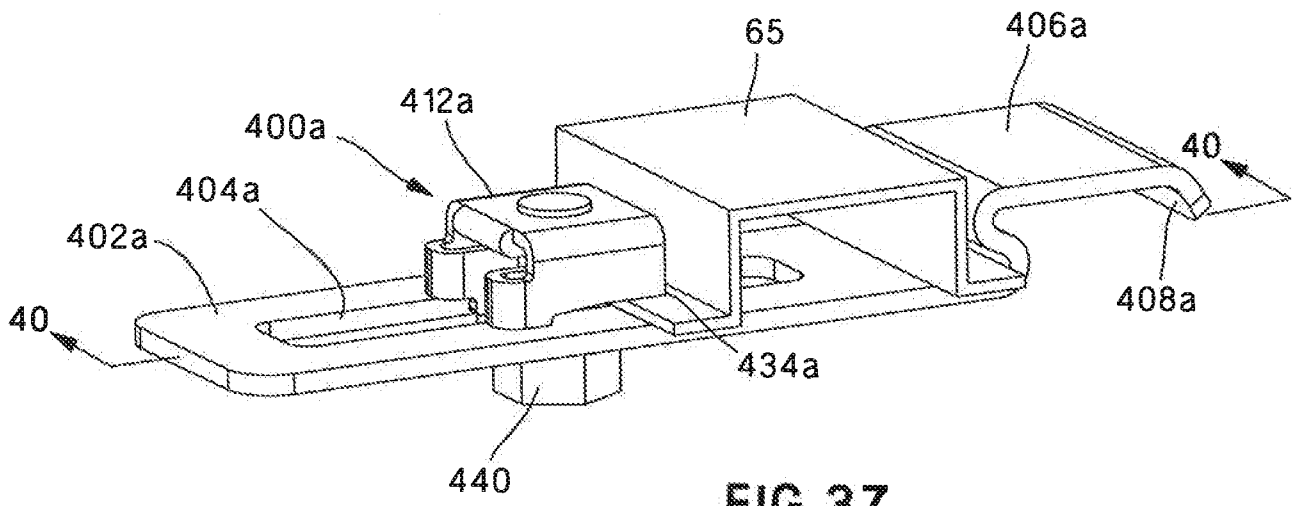

FIG. 37

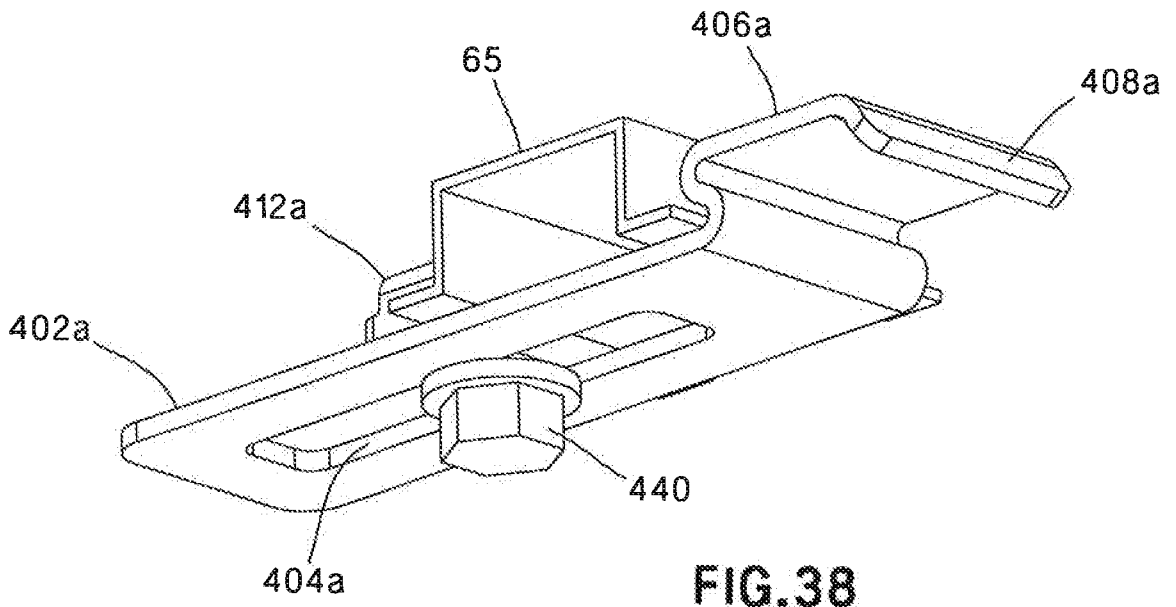

FIG. 38

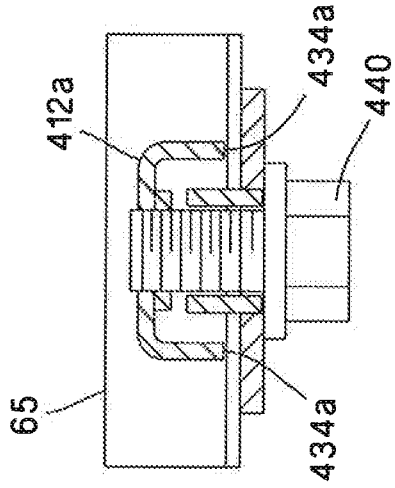

FIG. 39

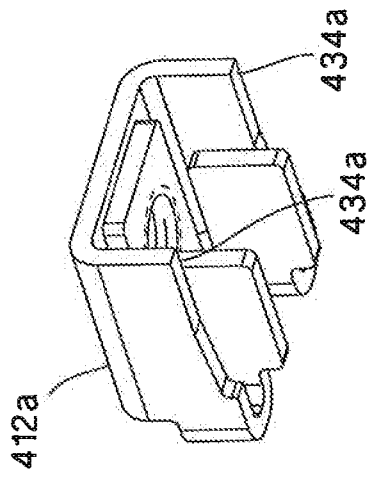

FIG. 40

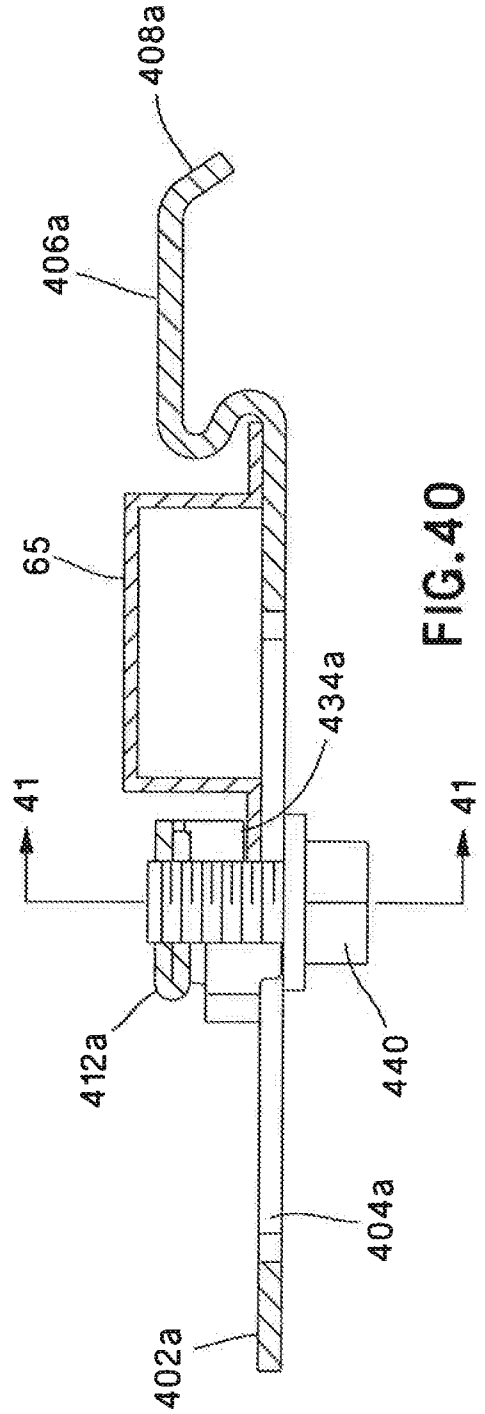

FIG. 41

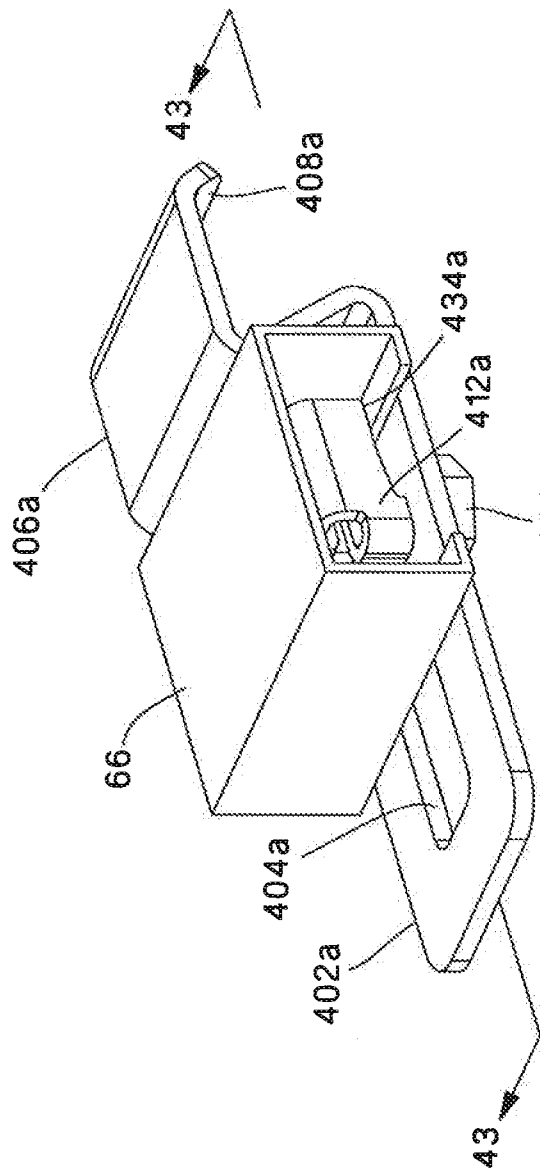

FIG. 42

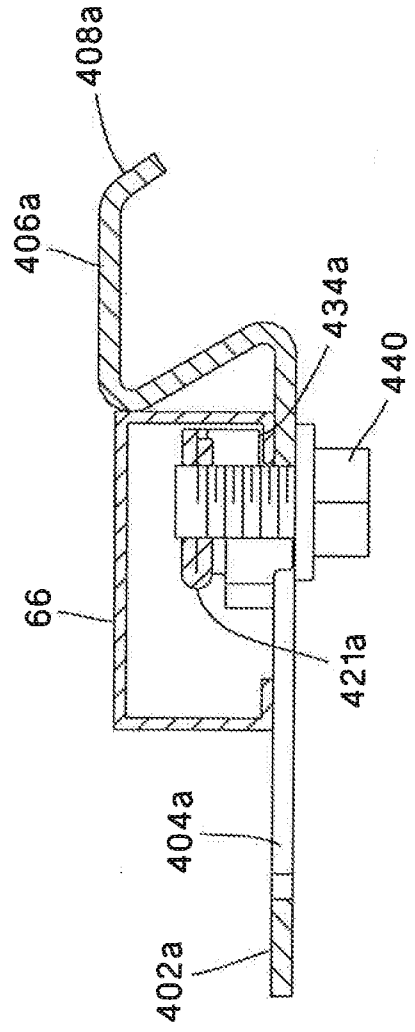
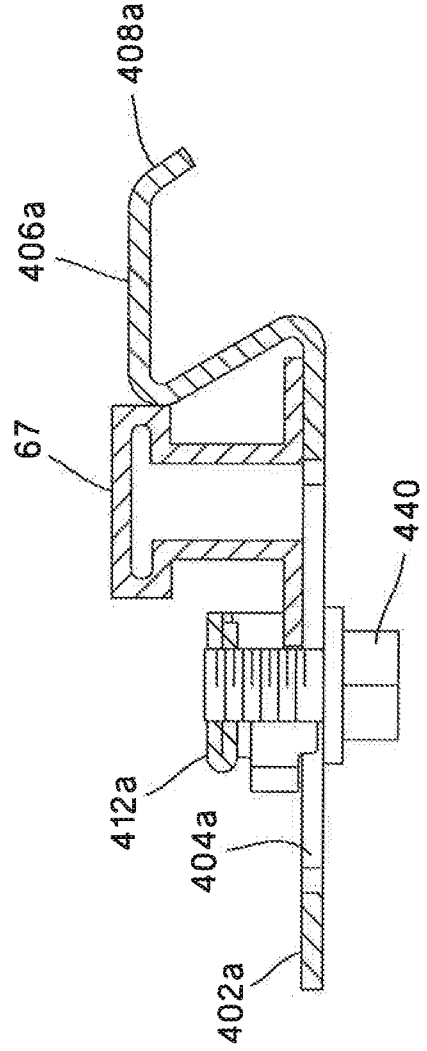
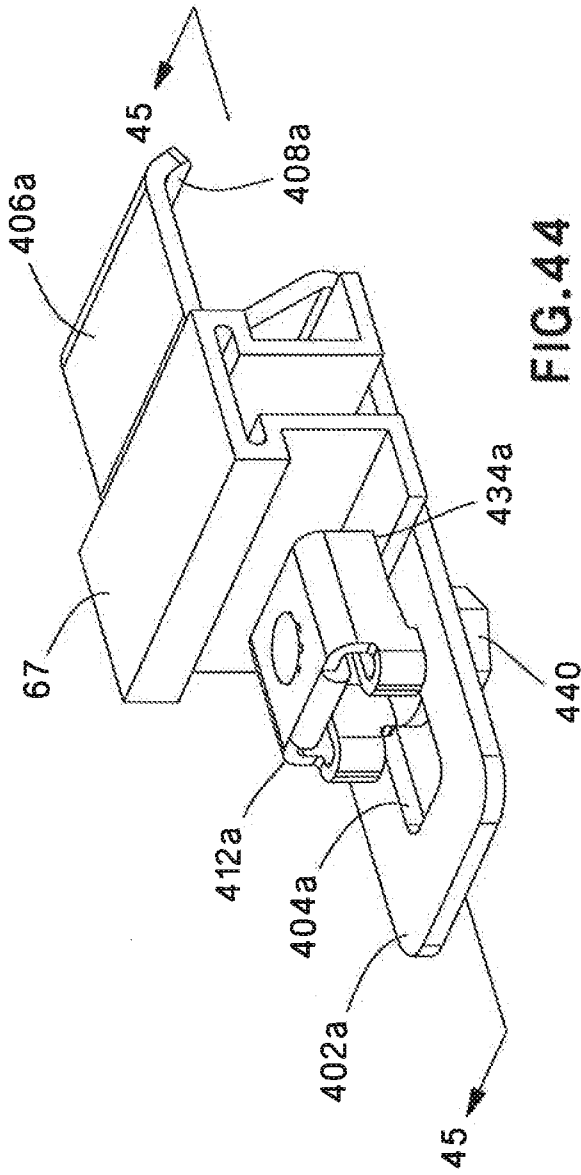

FIG. 43



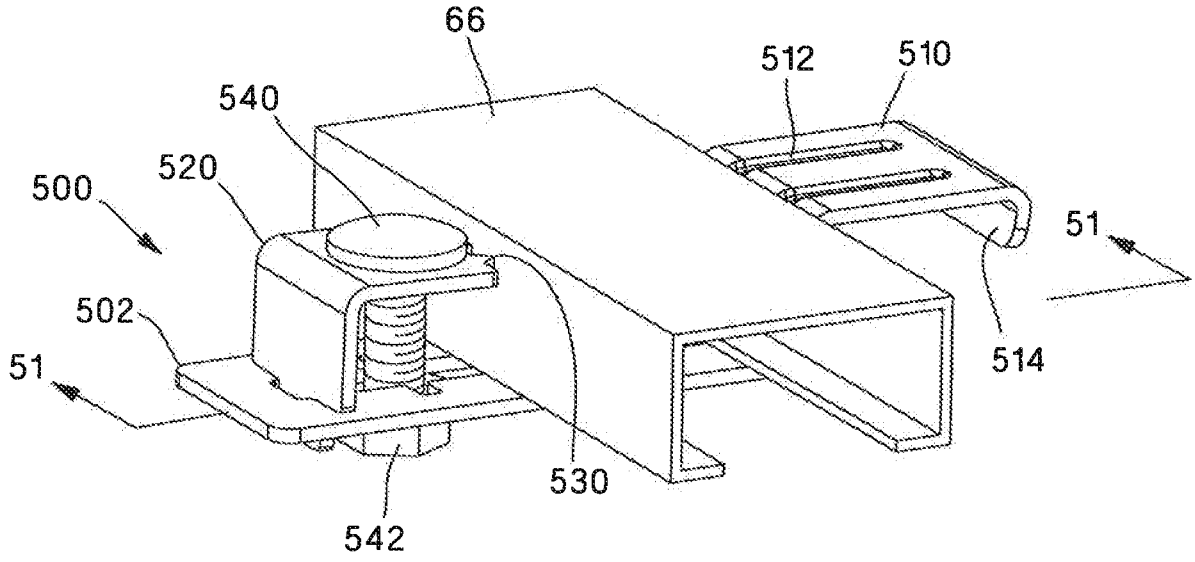

FIG. 46

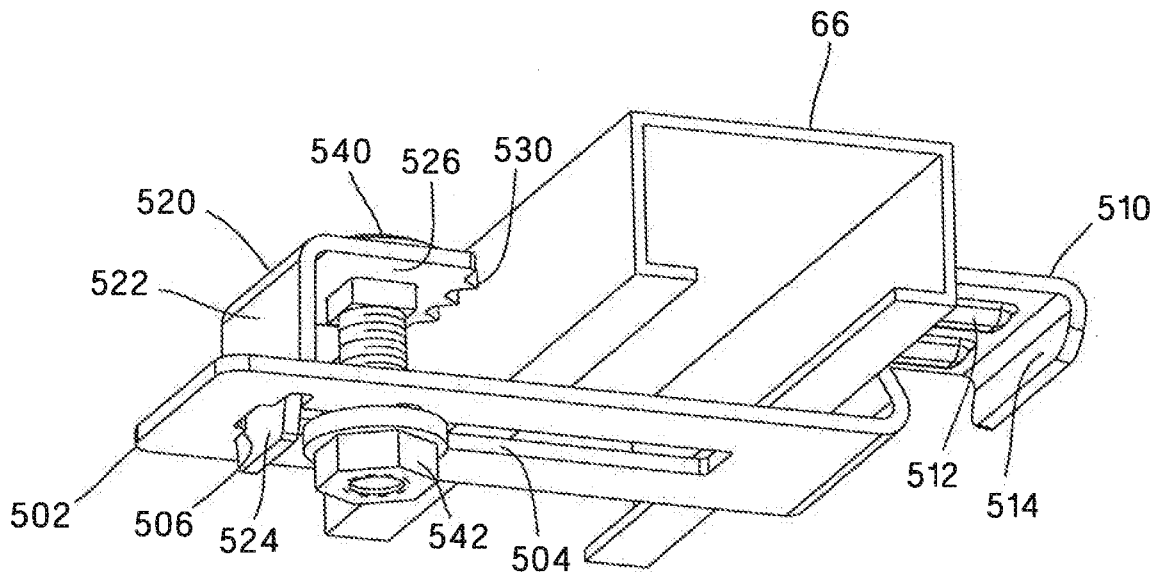

FIG. 47

26/38

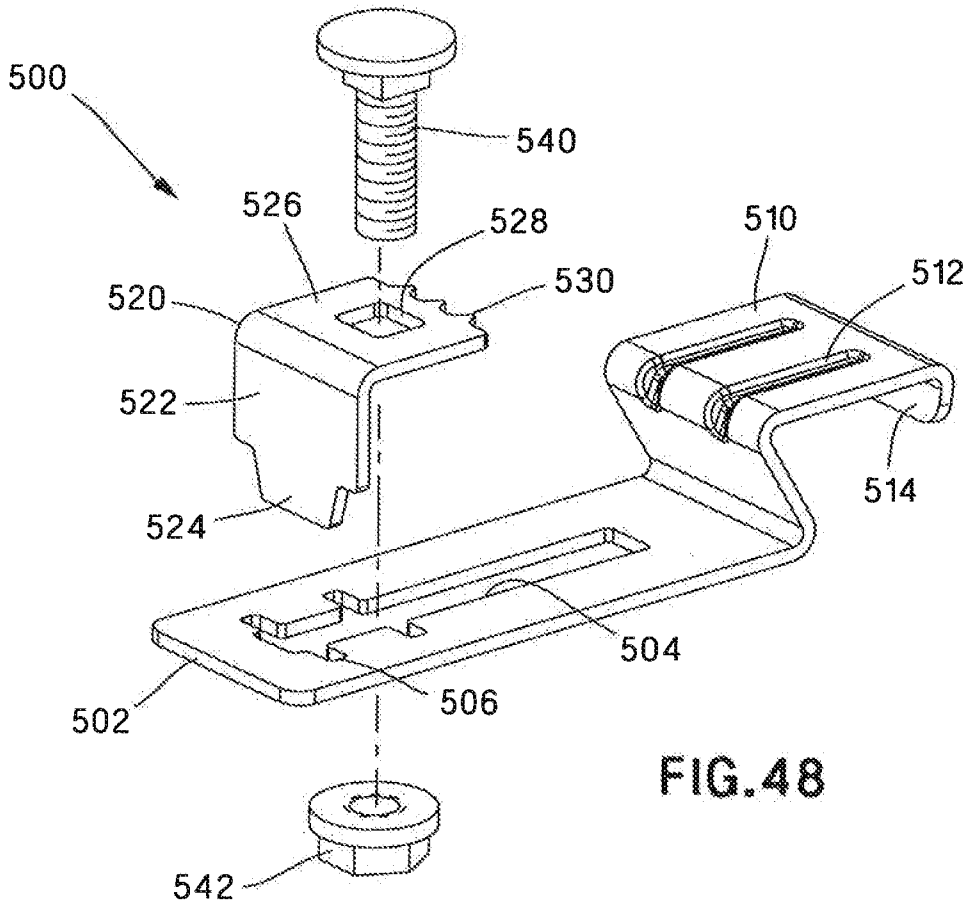

FIG. 48

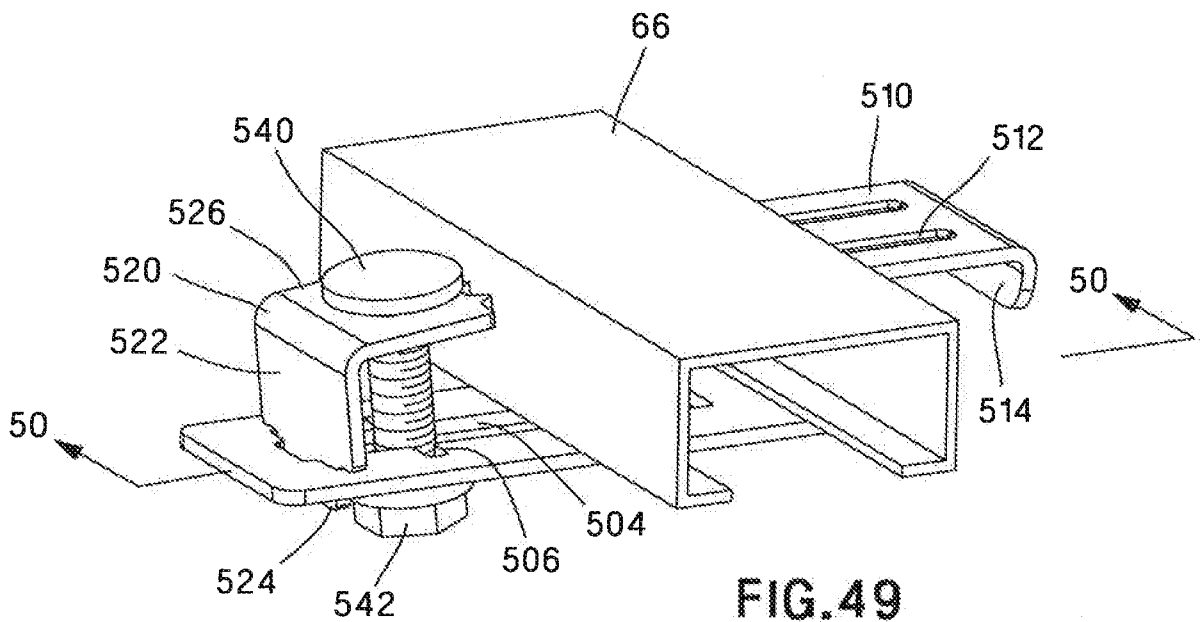
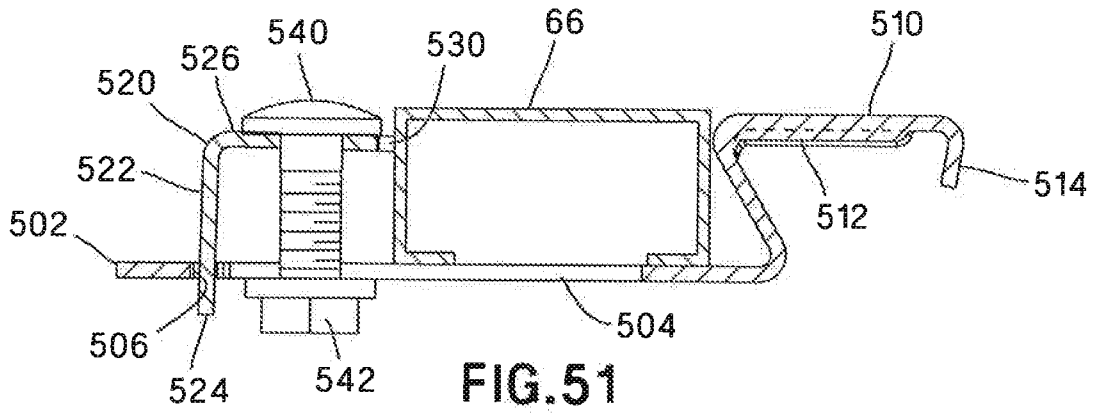
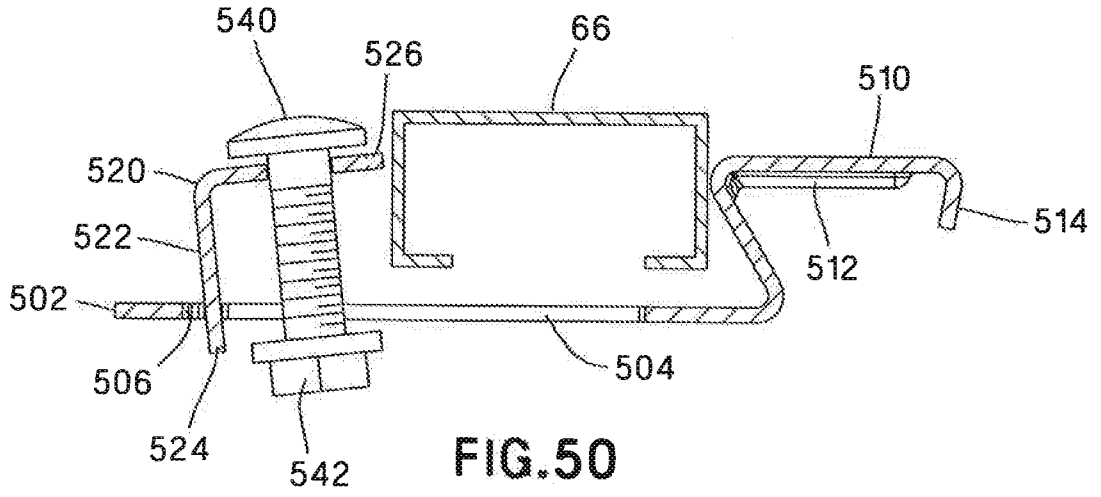

FIG. 49



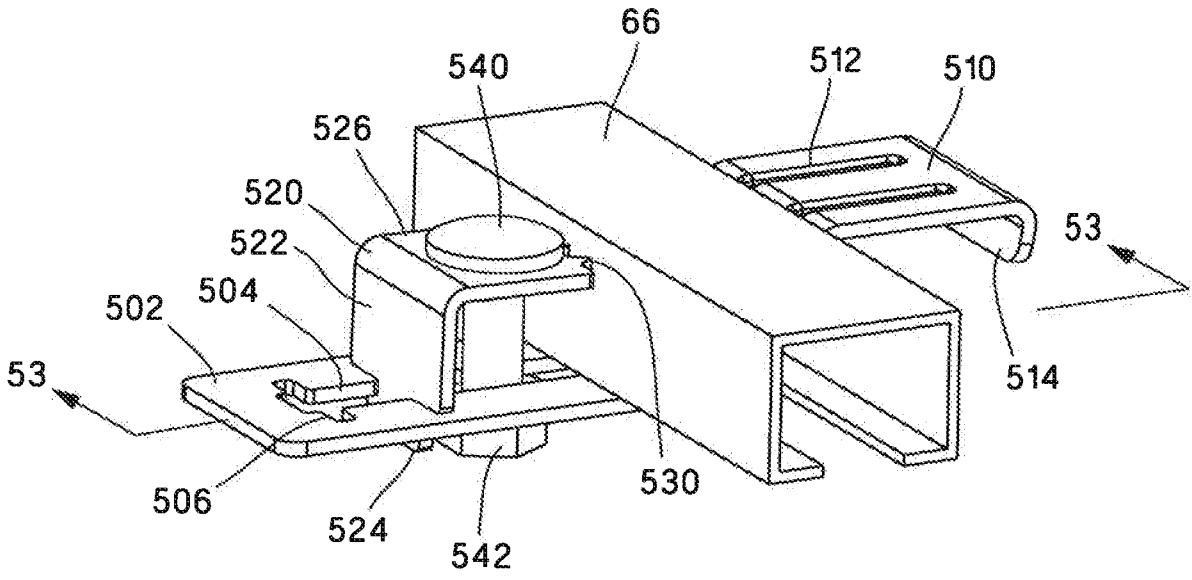

FIG. 52

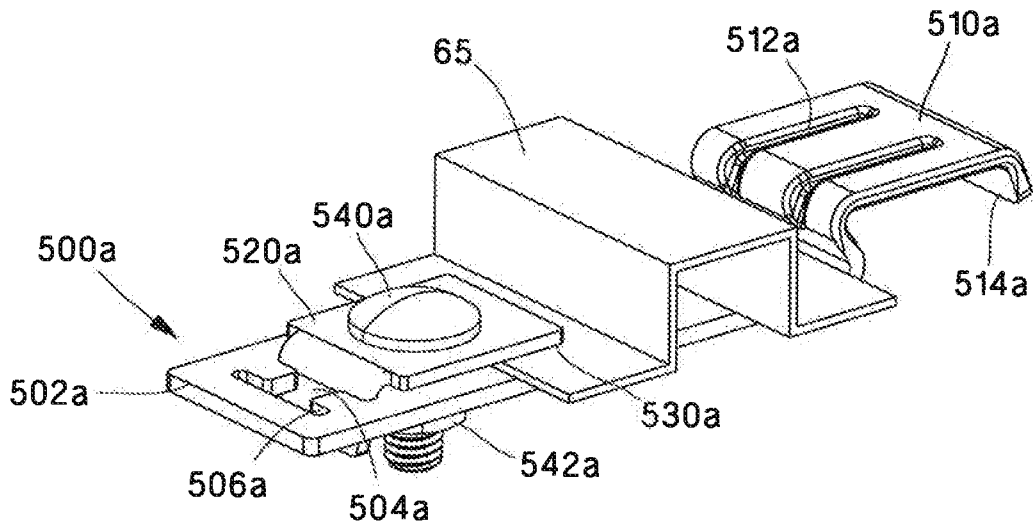

FIG. 52A

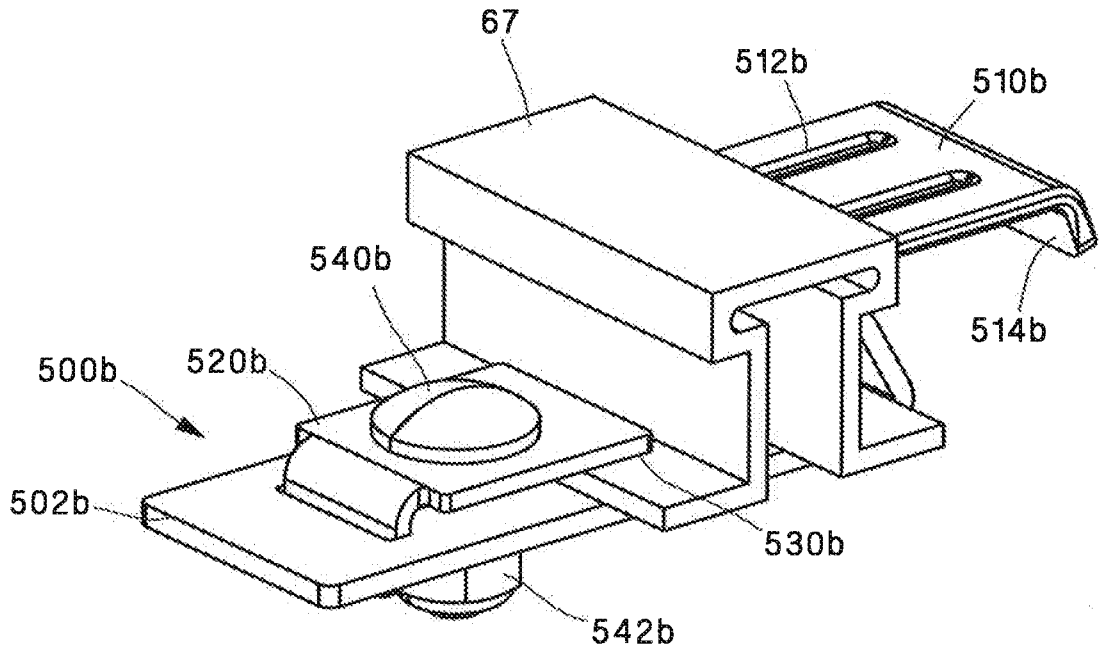

FIG. 52B

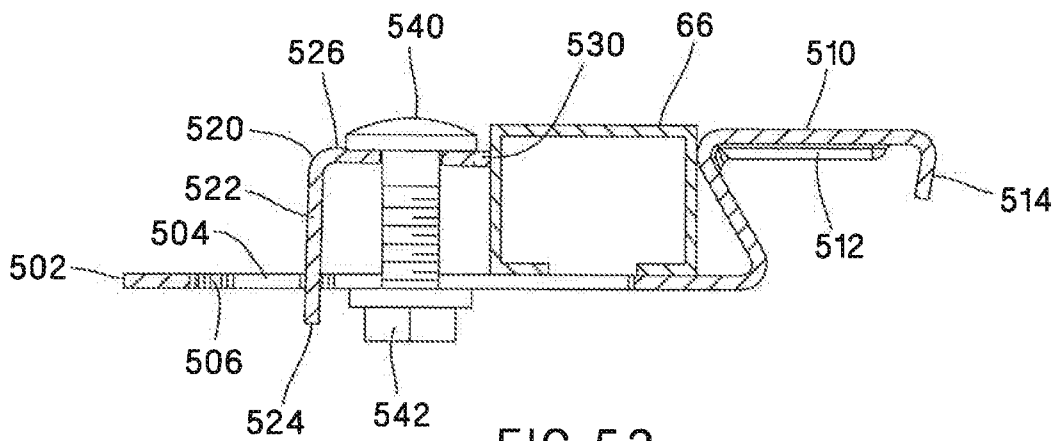

FIG. 53

30/38

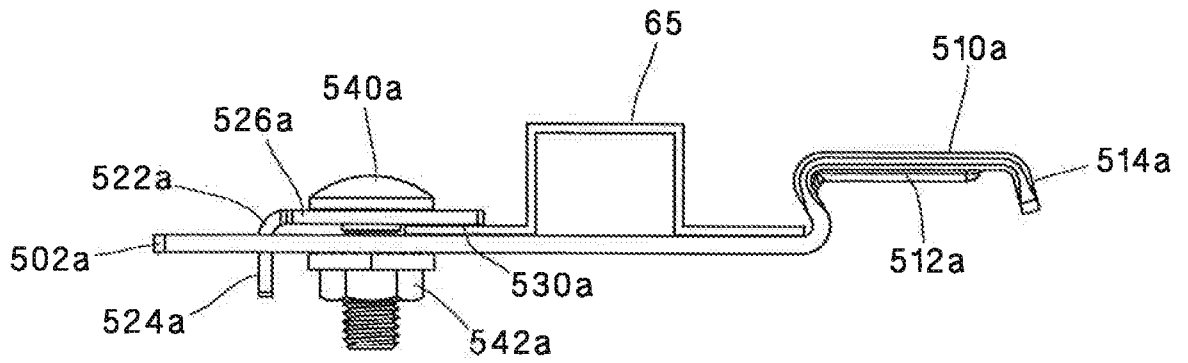

FIG. 53A

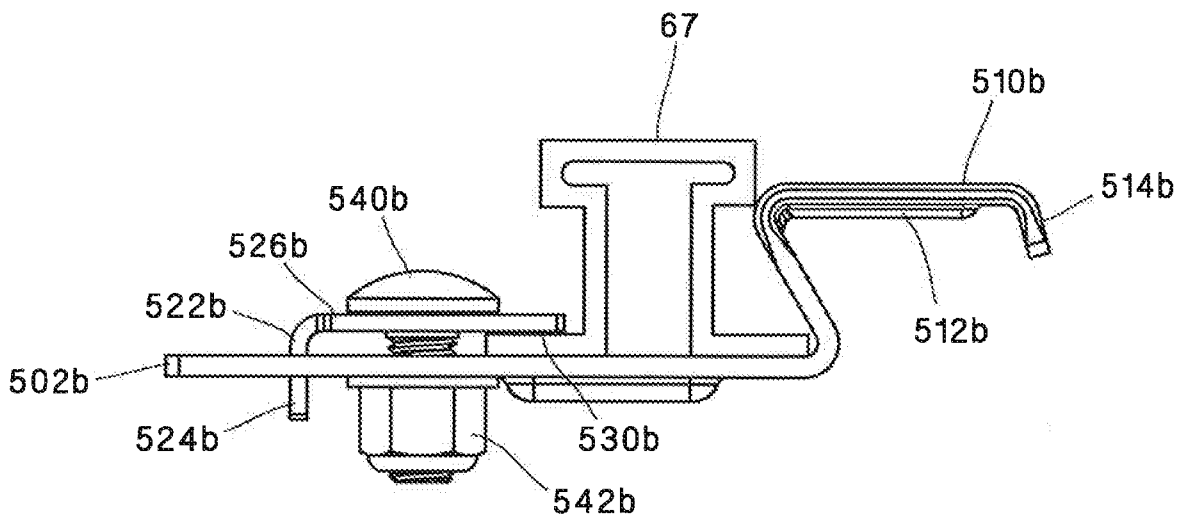

FIG. 53B

31/38

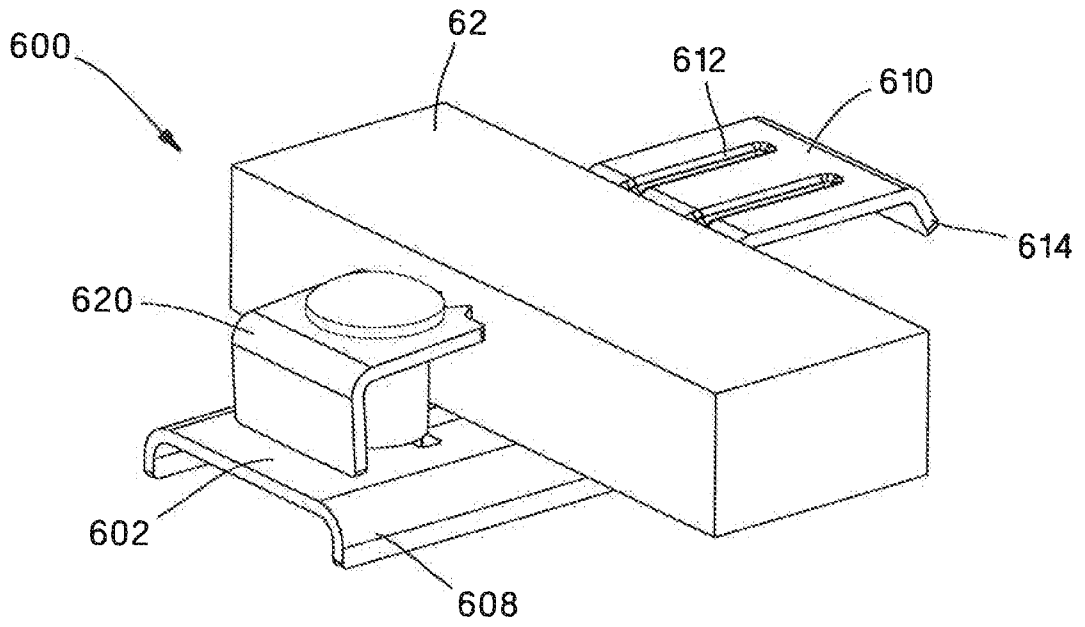

FIG. 54

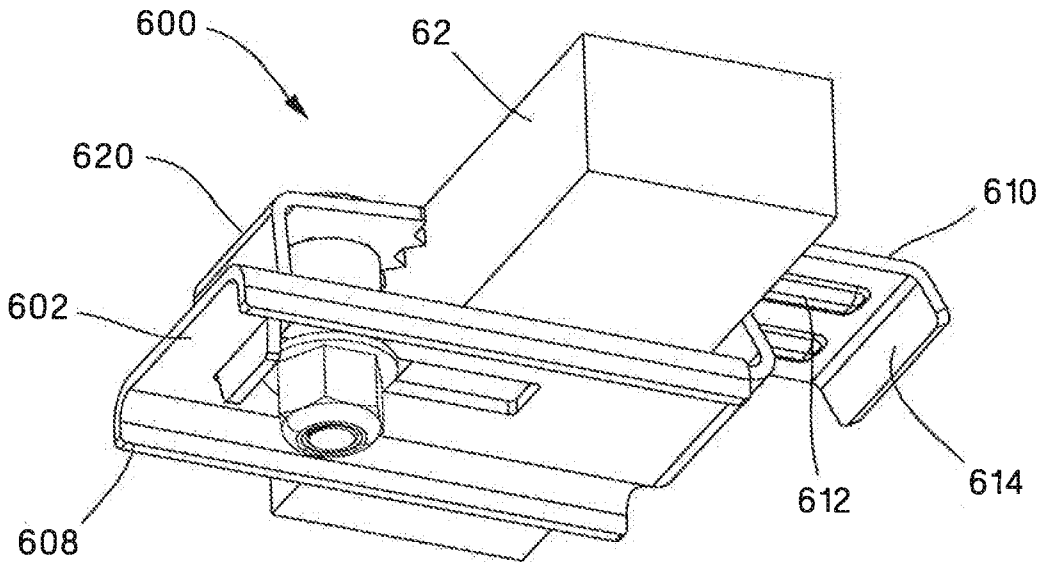

FIG. 55

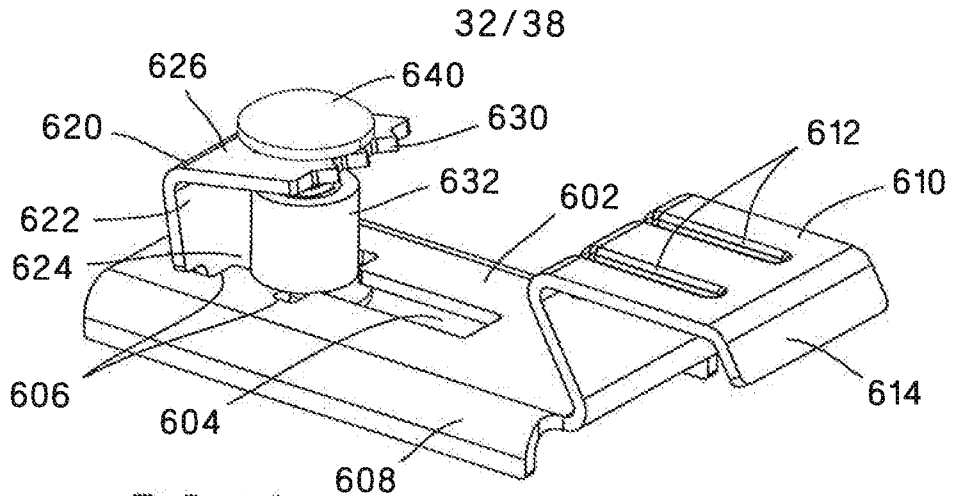

FIG. 56

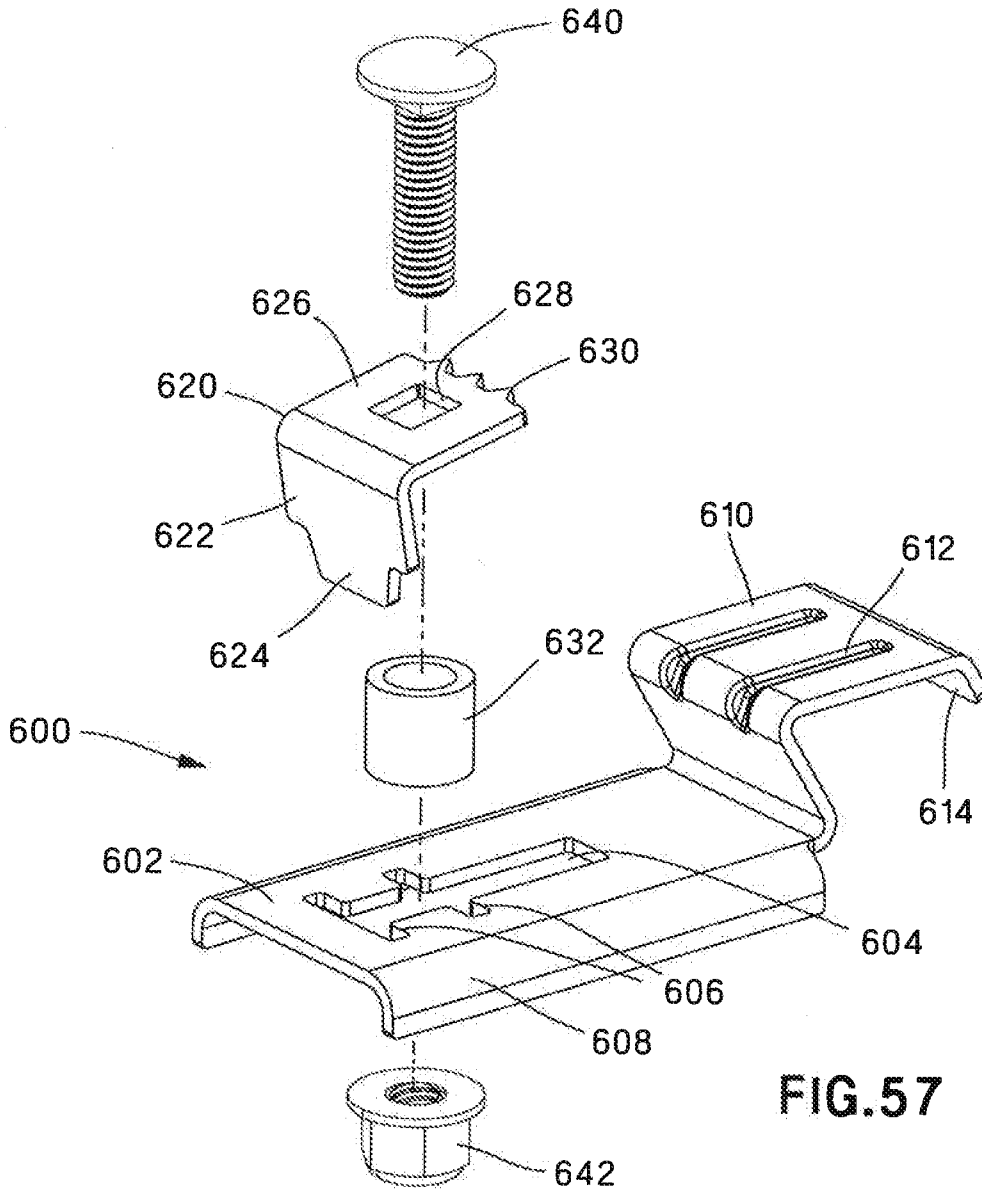
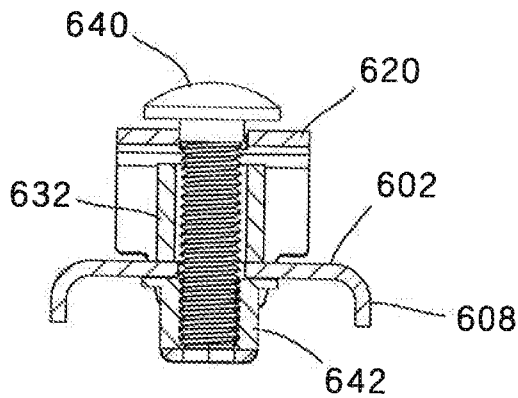
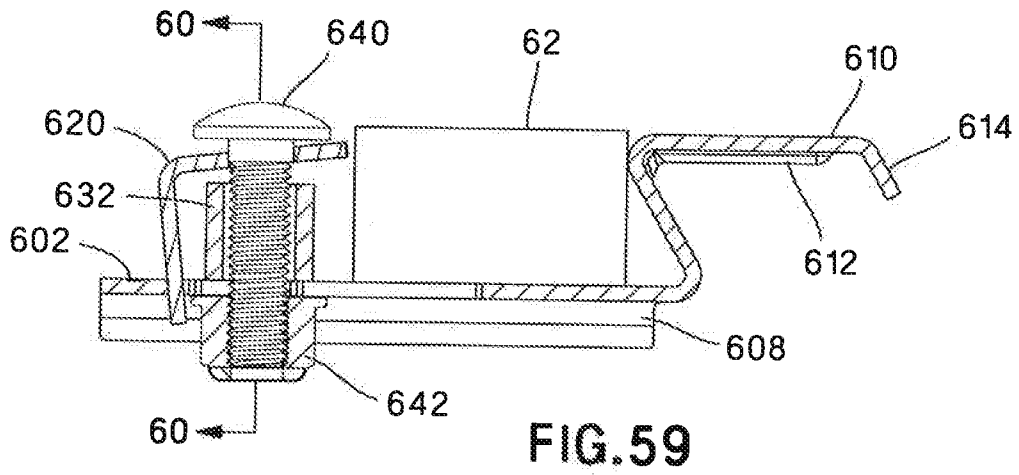
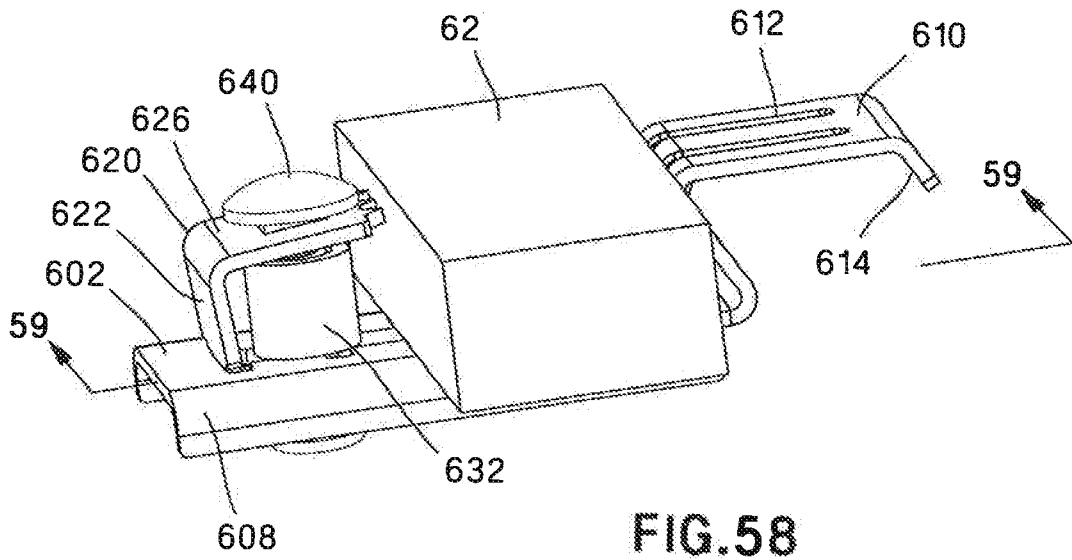
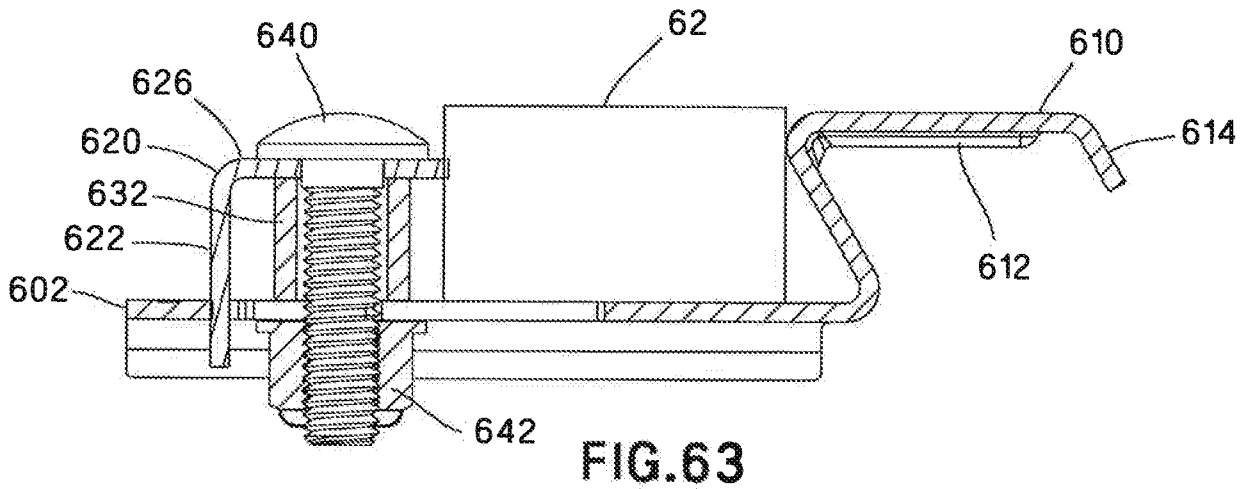
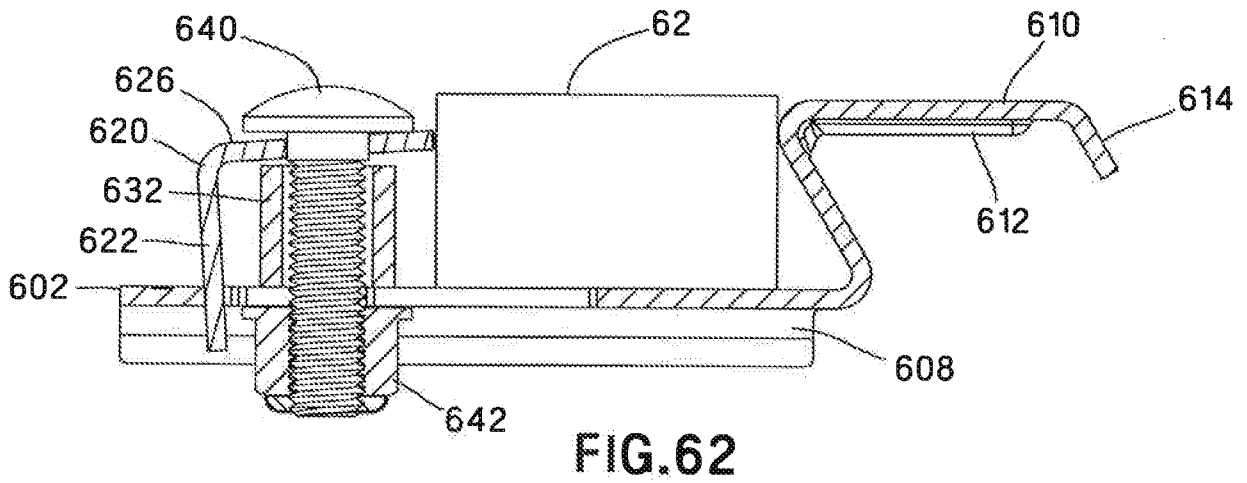
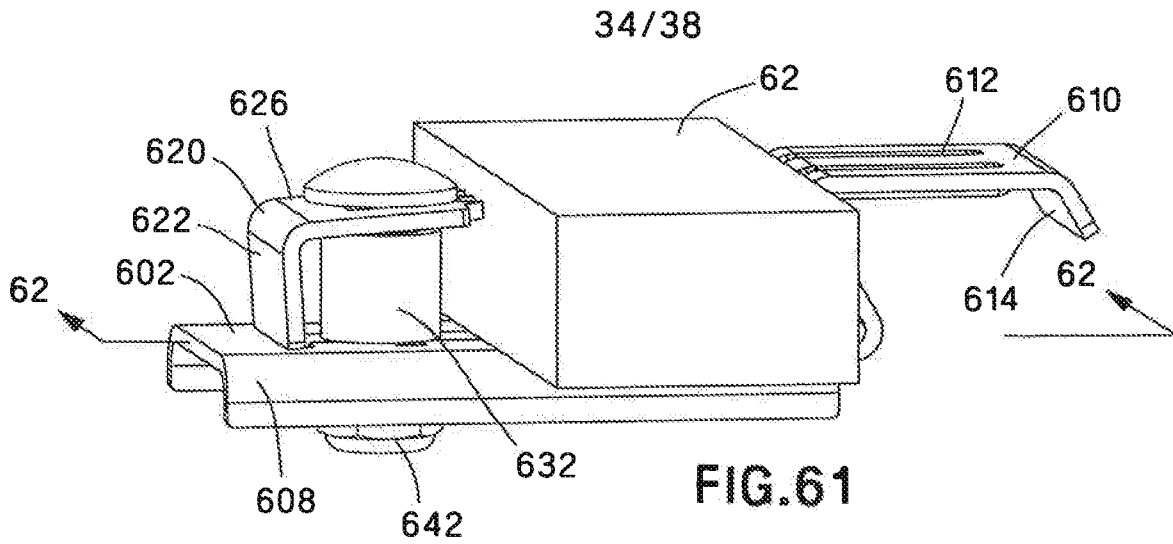

FIG. 57

33/38





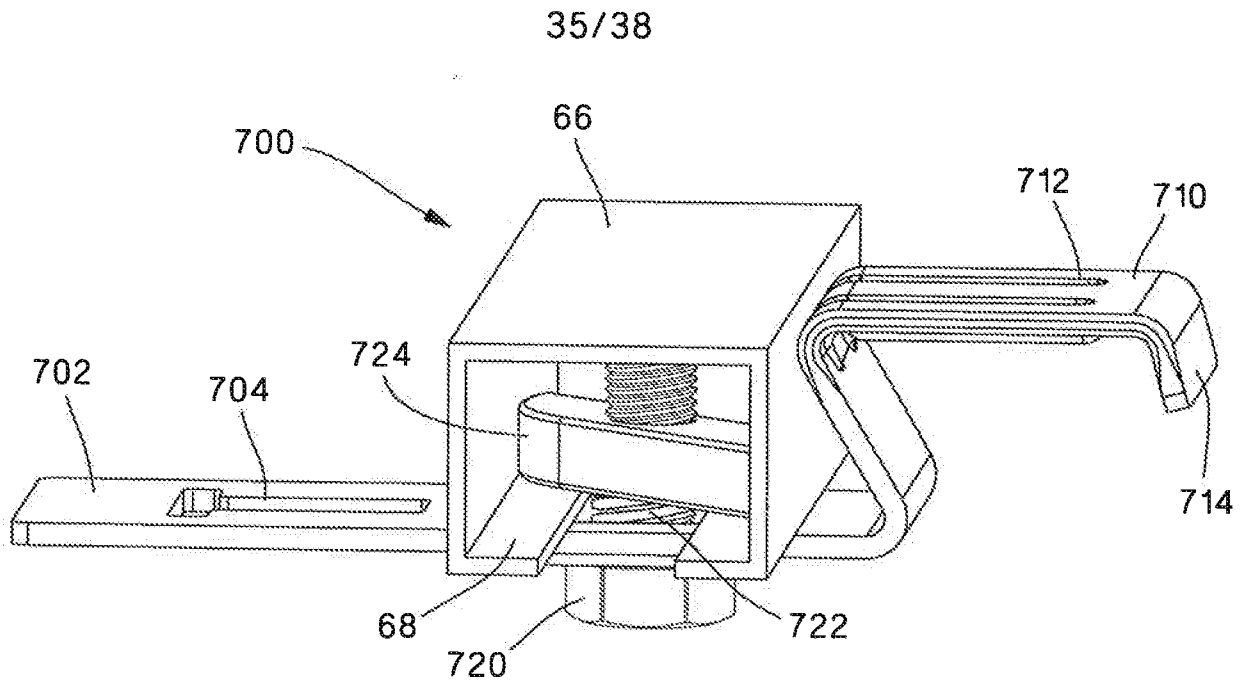

FIG. 64

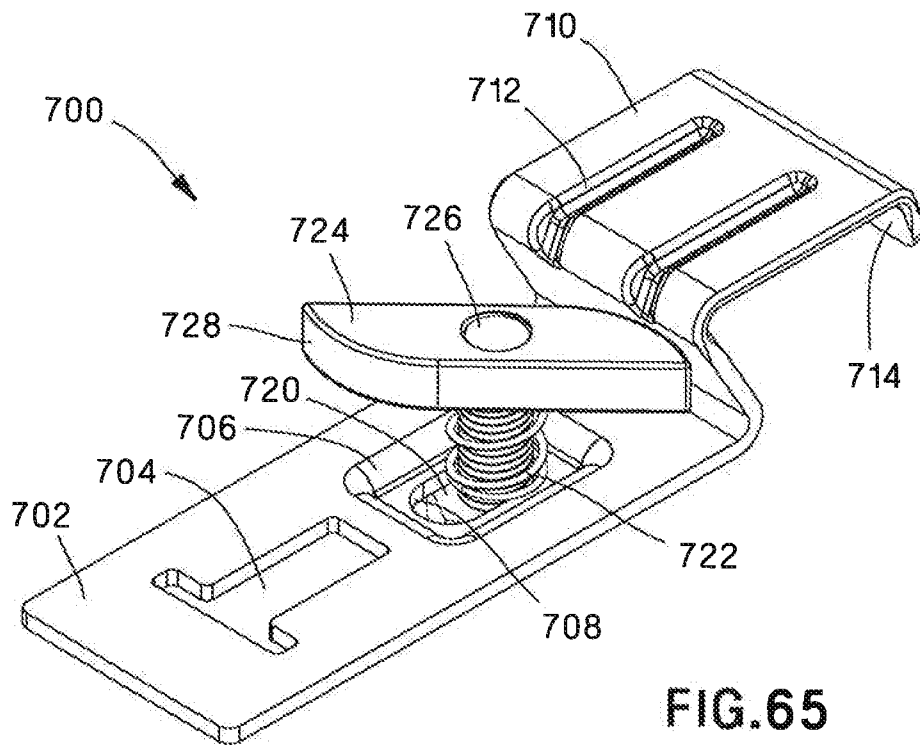

FIG. 65

36/38

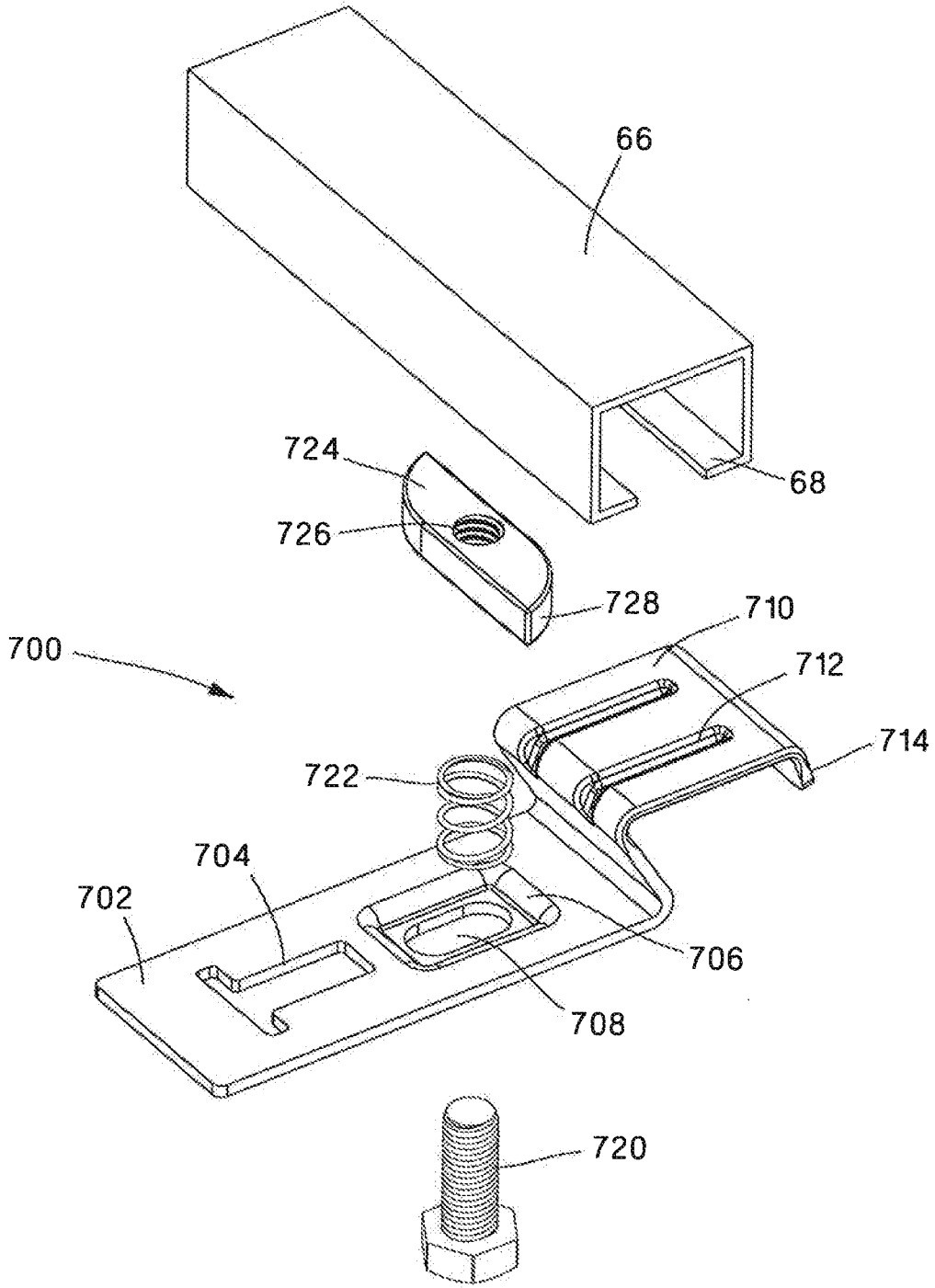

FIG.66

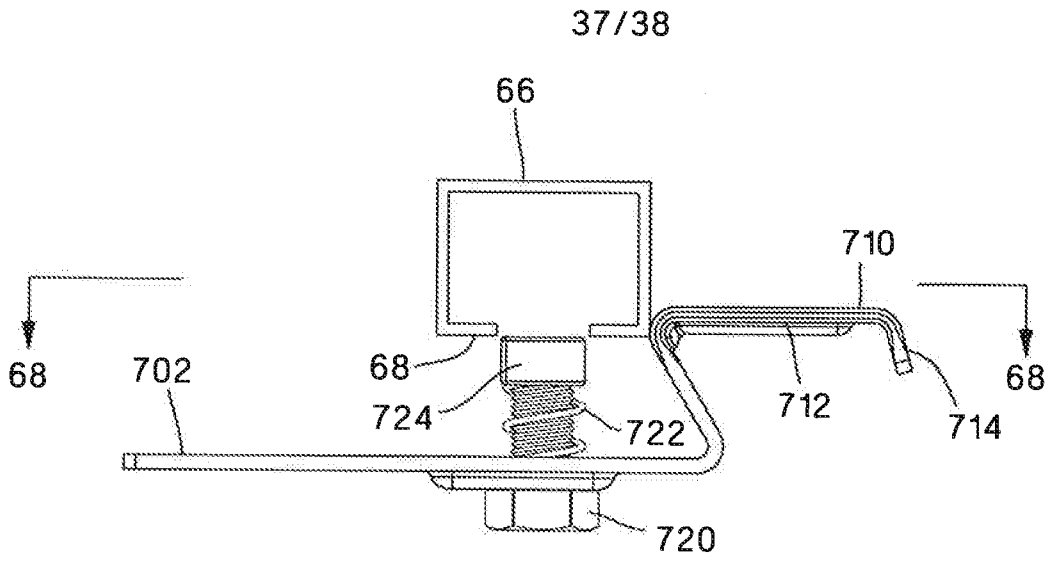

FIG. 67

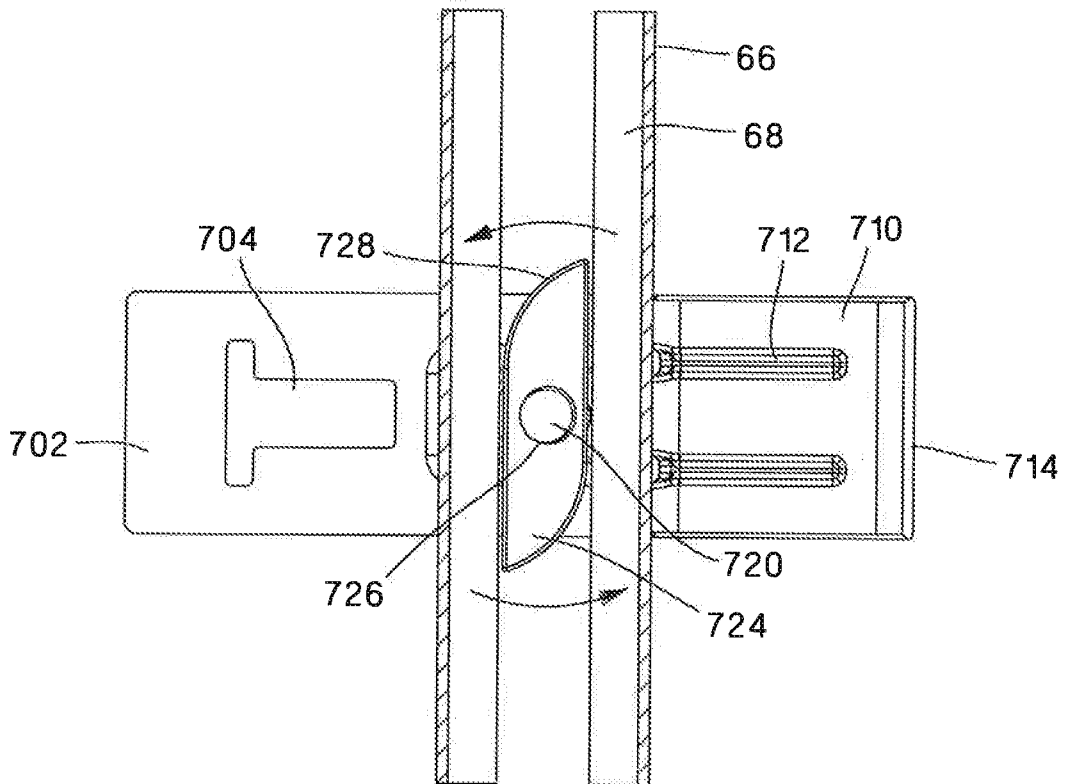

FIG. 68

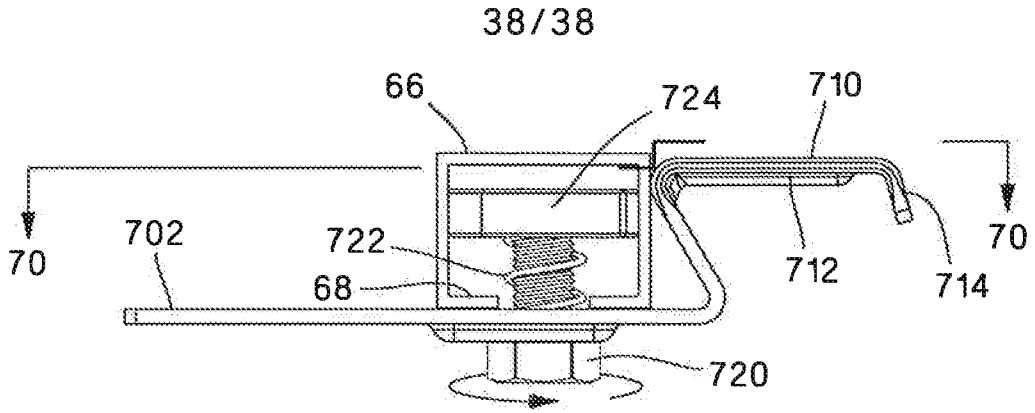

FIG. 69

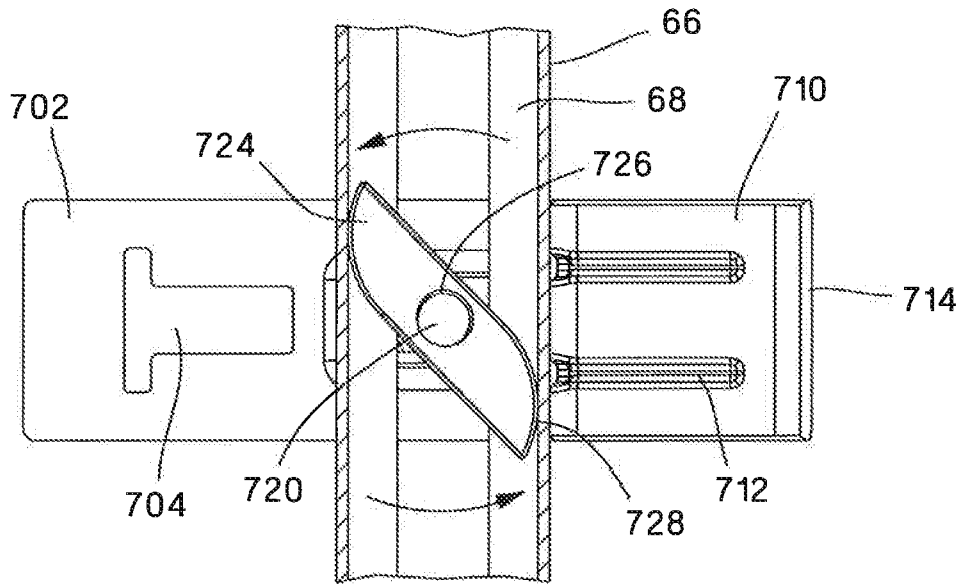

FIG. 70

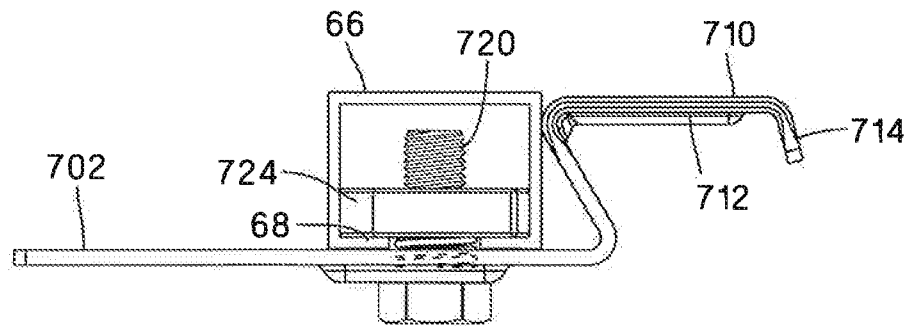

FIG. 71

