

Dec. 19, 1933.

J. FLOCKHART

1,939,965

STENCIL PRINTING MACHINE

Filed Feb. 18, 1930

3 Sheets-Sheet 1

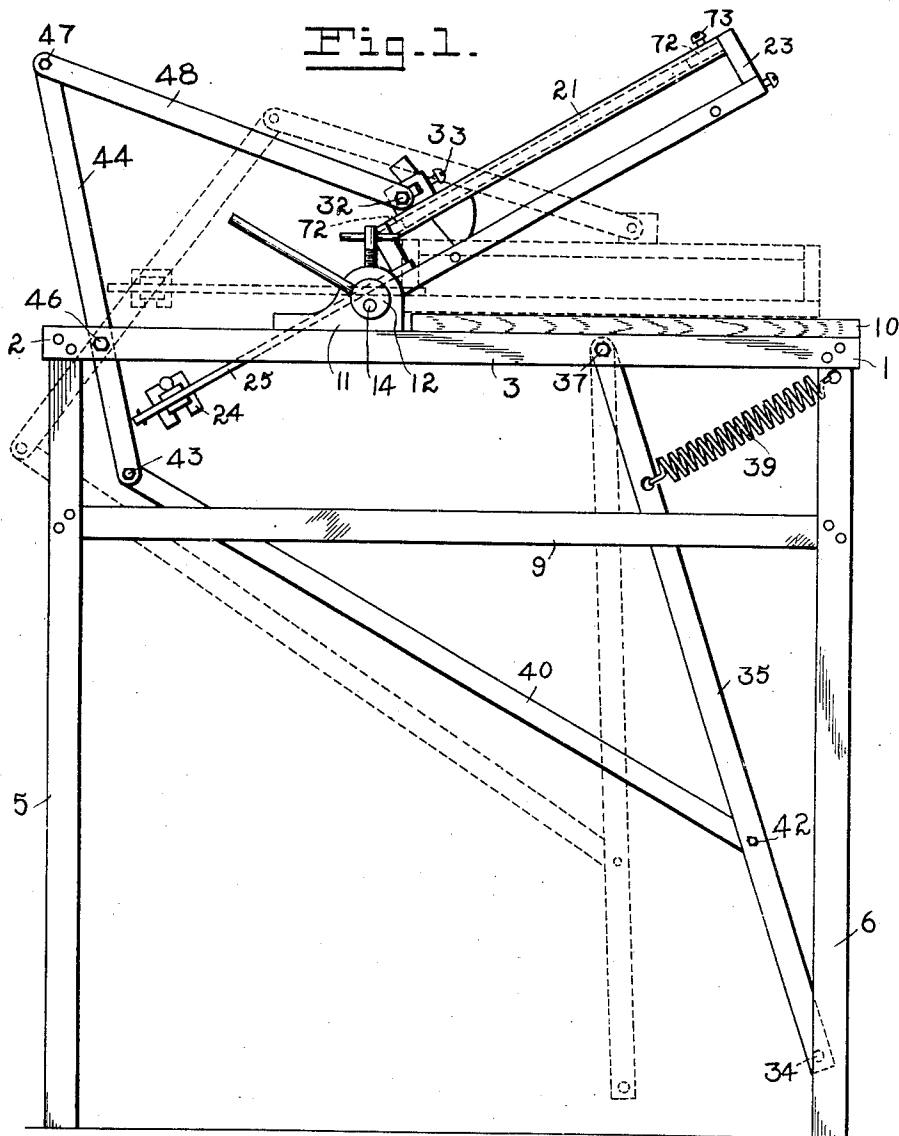

INVENTOR.  
James Flockhart.  
BY *Calvin Hill*  
ATTORNEY.

Dec. 19, 1933.

J. FLOCKHART

1,939,965

STENCIL PRINTING MACHINE

Filed Feb. 18, 1930

3 Sheets-Sheet 2

Fig. 2.

Fig. 3.

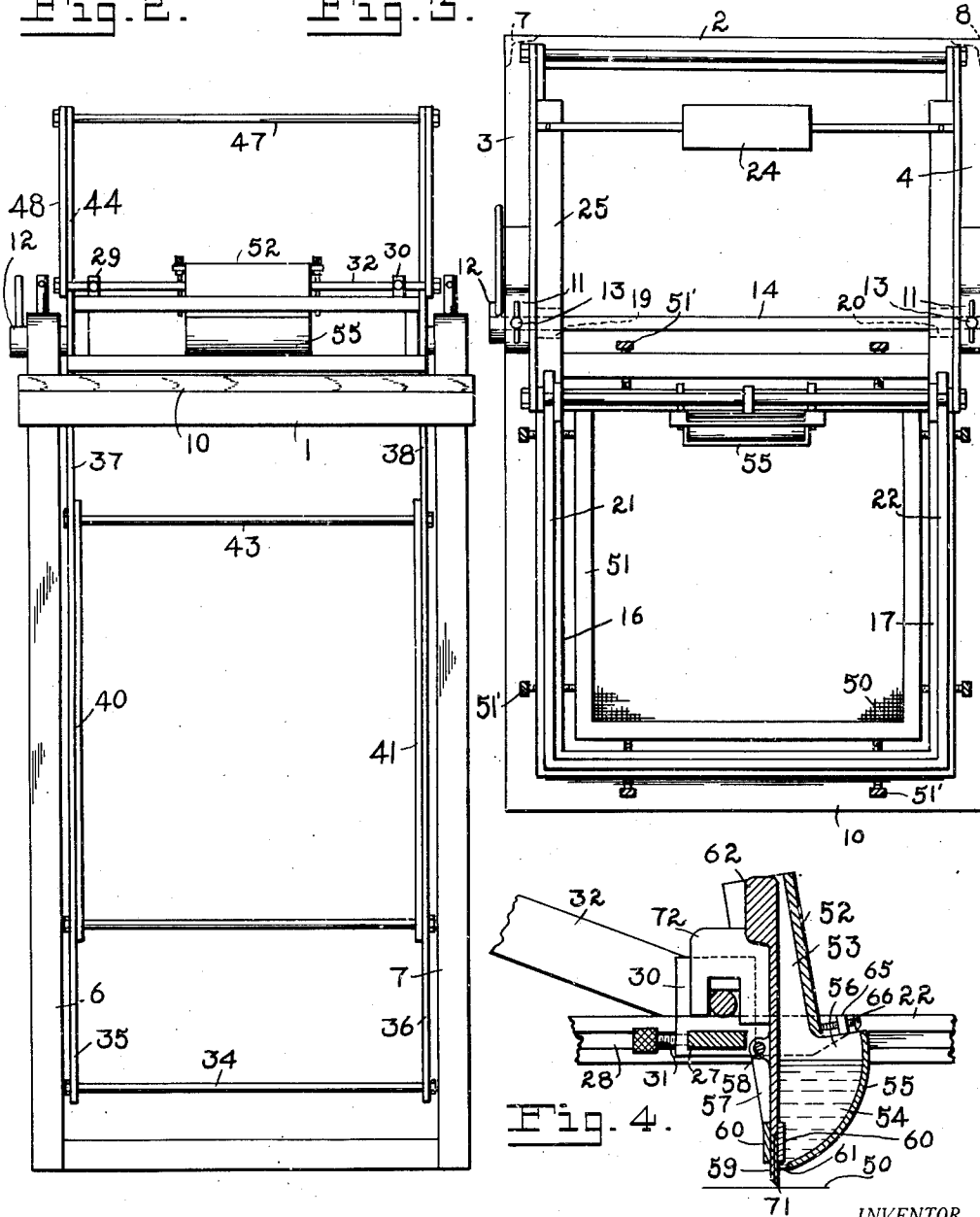

INVENTOR.  
James Flockhart  
BY *Reedman Lee*  
ATTORNEY.

Dec. 19, 1933.

J. FLOCKHART

1,939,965

STENCIL PRINTING MACHINE

Filed Feb. 18, 1930

3 Sheets-Sheet 3

Fig. 5.

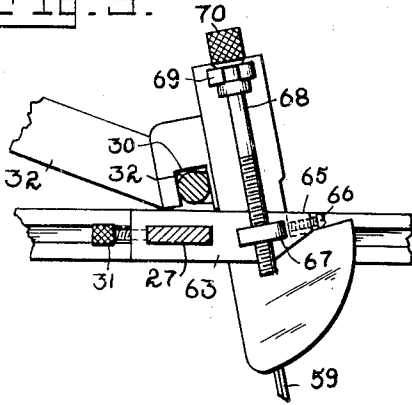

Fig. 6.

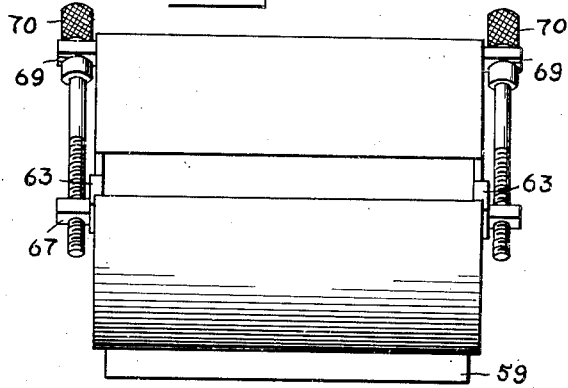

Fig. 7.

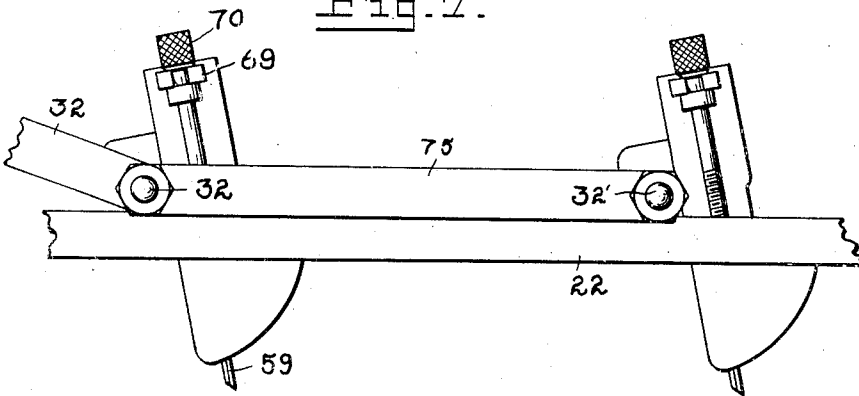
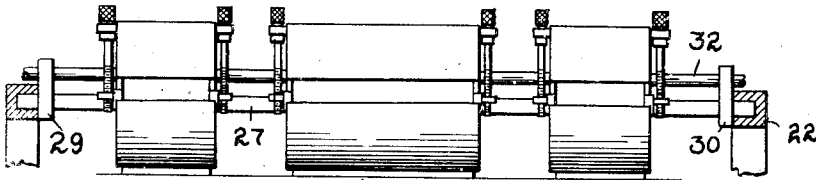

Fig. 8.



INVENTOR.  
James Flockhart.

BY *Barwin Lee*  
ATTORNEY.

# UNITED STATES PATENT OFFICE

1,939,965

## STENCIL PRINTING MACHINE

James Flockhart, San Francisco, Calif., assignor  
to The Flockhart Co. Inc., San Francisco, Calif.,  
a corporation of California

Application February 18, 1930. Serial No. 429,337

6 Claims. (Cl. 101—123)

This invention relates to improvements in stencil printing machines, and more particularly to a machine for producing silk screen stencil printing.

5 The principal object of the invention is to produce a machine which will perform or aid in the performance of the method of screen stencil printing.

10 Another object is to improve the quality of the product by providing means for accurate registration, uniform ink distribution and screen contact. A further object is to increase the output by facilitating the manual operations; other objects and advantages will appear as the description progresses.

15 In this specification and the accompanying drawings, the invention is disclosed in its preferred form. But it is to be understood that it is not limited to this form because it may be embodied in other forms. It is also to be understood that in and by the claims following the description it is desired to cover the invention in whatsoever form it may be embodied.

In the three sheets of drawings:

25 Fig. 1 is a side elevation of a machine constructed in accordance with this invention.

Fig. 2 is a front elevation of the same.

Fig. 3 is a plan view from above of the same.

30 Fig. 4 is an enlarged detail in vertical section viewed from the side of the fountain ink spreader.

Fig. 5 is a similar detail of the same in side elevation.

Fig. 6 is a front elevation of the same.

35 Fig. 7 is an enlarged detail of a pair of ink spreaders arranged in tandem on the machine.

Fig. 8 is a front elevation of a series of ink spreaders arranged in lateral spaced relation.

40 In detail the construction illustrated in the drawings, referring to Fig. 1, comprises the rectangular open main frame composed of the angle bars 1, 2, 3, 4, joined at the corners. This frame is supported upon the legs 5, 6, 7, 8, fixed into the corners of the main frame and properly braced as at 9 to form a rigid table structure.

45 The main frame may be a rigid casting, supported upon a bench or in any other suitable manner, other than that shown.

50 The bed or platen 10, is secured on top of the forward portion of the main frame. The pillow blocks 11, 11 are secured to the sides 3, 4 of the main frame to the rear of the bed 10. A pair of eccentric blocks 12 are rotatable in said pillow blocks respectively. These eccentric blocks are locked in adjusted relation by the set screws 13, 13 threaded in the pillow blocks, and seated in an-

nular grooves in the eccentric blocks to prevent lateral shifting.

The pivot shaft 14 extends across the width of the main frame and has its opposite ends fixed in the eccentric blocks 12, 12, eccentric to the centers of said blocks respectively. One of the blocks 12 protrudes beyond the edge of the pillow block to receive the radial handle 15 fixed therein.

60 The swing frame is composed of the side bars 16, 17, and the front bar 18 secured together. The side bars 16, 17, have the pivotal bearings 19, 20 fixed to the rear ends thereof, through which the shaft 14 extends, so that the swing frame pivots freely on the shaft 14 between the pillow blocks 12, 12.

70 The cross head guides 21, 22 are mounted above the swing frame on the risers 23, fixed thereon. The weight of the swing frame and assembled mechanisms is counter balanced by the counter weight 24, adjustably mounted upon the arms 25, 26, fixed to the swing frame and extending rearwardly on the opposite side of the pivotal axis 14.

75 The transverse crosshead bar 27, see Fig. 4, slides in the slots 28 in the guides 21, 22. This crosshead has the side brackets 29, 30, fixed thereto by the set screws 31, adjacent the guides 21, 22, and extending upward. The upper portions of these brackets are horizontally slotted to receive the transverse push rod 32 passing therethrough and abutting the adjusting screws 33, threaded in these brackets.

80 The crosshead bar 27 is reciprocated forward and back by a foot treadle mechanism, see Fig. 1. The foot treadle consists of a transverse bar 34 fixed in the lower ends of the side bars 35, 36, pivoted at 37, 38, respectively, to the main frame, and held normally forward by the tension of the springs 39, 39 on opposite sides between the legs 6 and 7 and the side bars 35, 36.

85 A pair of drag links 40, 41 are pivoted to a transverse rung 42 between the side bars 35, 36 at the front and to a similar rung 43, between the ends of a pair of vertical levers 44, 45, which are fulcrumed intermediate their lengths at 46, 46 to the main frame. The upper ends of these levers are connected by a third rung 47.

90 The equalizing links 48, 49, are pivoted at their upper ends on the rung 47 and at their lower ends on the push rod 32. When the treadle 34 is pushed back, the push rod 32 is pushed forward through the connected mechanisms as indicated in dotted lines in Fig. 1, carrying the crosshead bar 27 forward by pressure against the adjusting screws 33, see Fig. 4. The treadle mechanism is returned to normal by the springs 39.

The stencil screen 50, usually consists of "bolting cloth" of the desired mesh stretched on a frame 51, suspended in the swing frame by the adjusting screws 51' threaded therein and engaging the screen frame, see Fig. 3, by which means the screen frames can be adjusted to insure registration with the work sheet on the bed 10, for consecutive impressions. For further particulars see my copending application, Serial Number 396,083, filed September 30, 1929, entitled Stencil frame.

To adjust the swing frame vertically to accommodate different thicknesses of work sheets on the bed 10, ranging from a sheet of paper to thick boards, and the like, or sheets in stacks, the handle 15 is swung downward or upward to rotate the eccentric blocks 12, 12 to raise or lower the shaft 14 until the screen 50 stretched taut on the frame 51 rests flat upon the surface to be printed. This adjustment is maintained by screwing down the set screws 13, 13.

The fountain brush for feeding the ink or paint to the screen stencil is preferably constructed as best shown in Fig. 4. It consists of a U shaped shell having the front plate 52 and the side plates 53, 53 integral therewith. The sides 53 extend below the plate 52 to form the ends 54, 54 of the fountain and are joined by the curved plate 55, the top of which extends beyond the plate 52 to leave the filler opening 56.

The gate consists of a plate 57 pivoted at 58, between the ends 54. The lower portion of the gate is provided with a strip of leather or rubber compound 59, clamped between the plates 60, 60 engaging the gate. This strip 59 contacting the edge of the lip 61, seals the outlet from the fountain. The paint or ink used is about the consistency or body of printer's ink and does not tend to leak from the fountain until the gate is opened at 61. This opening may be accomplished manually by compressing the upper portion 62 of the gate and the plate 52 together in the hand, which swings the gate 57 on the pivot 58.

For further particulars regarding the fountain brush, see my copending application, Serial Number 396,082 filed September 30, 1929, and entitled Fountain brush.

The fountain is supported between the two brackets 63, 63, slidable laterally on the crosshead bar 27, whereupon they are held in adjustment by the set screws 64, see Fig. 5. These brackets are provided with overhanging front lugs 65, having set screws 66, engaging the front plate 52 to hold the fountain in vertical adjustment between the brackets 63, 63.

These brackets are respectively provided with the lateral lugs 67, having the adjusting spindles 68, threaded therein. These spindles are swiveled in the open notched lugs 69, extending laterally from the sides 53, 53 of the fountain. When the knurled heads 70 are turned the fountain is raised, lowered, or leveled, at the will of the operator, to determine the pressure of the strip 59 on the screen 50.

This strip acts as a squeegee for distributing the ink from the fountain and to scrape the superfluous ink off the stencil in the screen 50. To aid in this effect and to reduce the pressure on the return stroke, the lower edge of the strip is beveled as at 71. The pivot 58 is to the rear of the plane of the gate 57, so that the gate in swinging forward to close the opening at 61 also lifts the lip of the squeegee 59 at 71, above the screen 50 for the return stroke. This lifting action avoids the possibility of redistributing sur-

plus ink on the screen during the return stroke of the fountain 54.

To automatically open the fountain on the forward stroke and close the same on the return stroke, the gate is provided with the lug 72 engaging the push rod 32. The extent of the opening of the fountain at 61, is determined by the adjustment of the screws 33, 33 in the brackets 30. The lost motion of this rod in the slots in the brackets 30, causes the rod to open the fountain and spill some ink on the screen transversely across the width of the fountain at 61, before the rod engages the screws 33 and pushes the cross head 27 and fountain the length of the desired stroke to cover the stencil design.

The stops 72, 72 are adjustably fixed by the screws 73, in the crosshead guide slots 28, against which the crosshead 27 abuts, at the opposite ends of its stroke respectively.

Recent advances in this art have produced ink especially adaptable for use in fabric screen stencils; also emulsions for impregnating the screen by means of which stencil designs can be produced photographically by exposing the screen behind negatives carrying the desired designs. After this exposure to light the stencil design portions of the emulsion are washed from the screen with water or suitable solvents, exposing the screen mesh at desired portions. The stencils can be produced by the old manual method or otherwise.

For multicolor work a stencil is made for each color area in the design and the color sequence carried out by substituting the screen frames 51 in the swing frame. It is possible to accomplish exact registration on the bed 10 of each color by adjusting the screen frame by means of the screws 51'. Color blending is accomplished by superimposing transparent inks in proper sequence.

To utilize the full capacity of the machine, the screen 50 may carry several stencil designs dispersed throughout its area, in which case a number of fountains may be disposed along the width of the crosshead 27, as in Fig. 8. It is also possible to use a full stroke of the crosshead on several small stencils by arranging the fountain in tandem, as in Fig. 7. In this instance the side connecting links 75 are attached to the push rod 32, and engage a similar rod 32', similarly equipped with the fountain operating mechanisms previously described.

The treadle mechanism, 34 to 43, may be dispensed with, retaining the equalizing mechanism, 44 to 48, which maintains the transverse parallelism of the crosshead 27 during its stroke, and the rod 32 pulled forward and pushed back by hand. This is desirable in the smaller sizes of portable machines.

Having thus described this invention what I claim and desire to secure by Letters Patent is:

1. A stencil printing machine comprising a main frame; a swing frame pivoted on said main frame and adapted to carry a stencil; inking means slidably guided on said swing frame and means for raising and lowering the pivotal center of said swing frame.

2. A stencil printing machine comprising a main frame; a swing frame pivoted on said main frame and adapted to carry a stencil; a crosshead slidably guided on said swing frame; an ink fountain and spreader on said crosshead; and means for moving said crosshead and automatically opening and closing said fountain on

the forward and reverse stroke of said cross-head, respectively.

stencil; a crosshead slidably guided on said swing frame; an ink fountain fixed on said crosshead and having a pivotal gate; a push rod slidably engaging said cross head and gate; a pair of levers pivoted to said main frame; equalizing links pivoted to said levers and said push rod, a treadle pivoted to said main frame and connected to said levers, and resilient means interposed between said treadle and main frame.

3. A stencil printing machine comprising a main frame; a swing frame horizontally pivoted on said main frame and adapted to carry a stencil; means for raising and lowering the pivotal center of said swing frame; inking means guided on said swing frame and reciprocating means connected with said inking means.

6. A stencil printing machine comprising a main frame; a counterbalanced swing frame pivoted on said main frame and adapted to carry a stencil; means for raising and lowering the pivotal center of said swing frame; an ink fountain slidably guided on said swing frame and having a movable gate and means for opening said gate and advancing said fountain across said screen and closing and retracting said gate across said frame.

4. A stencil printing machine comprising a main frame; a swing frame pivoted on said main frame and adapted to carry a stencil; an ink fountain slidably guided on said main frame and having a pivotal gate; a pair of levers pivoted on said main frame and equalizing links pivoted to said levers and said gate; a treadle pivoted on said main frame and connected to said levers.

5. A stencil printing machine comprising a main frame; a counterbalanced swing frame pivoted on said main frame and adapted to carry a

JAMES FLOCKHART. 95

25	100
30	105
35	110
40	115
45	120
50	125
55	130
60	135
65	140
70	145