

Nov. 10, 1953

B. KATZENBERGER

2,658,355

REFRIGERATOR AND DEEP FREEZER SYSTEM

Filed Nov. 15, 1950

3 Sheets-Sheet 1

Fig. 1.

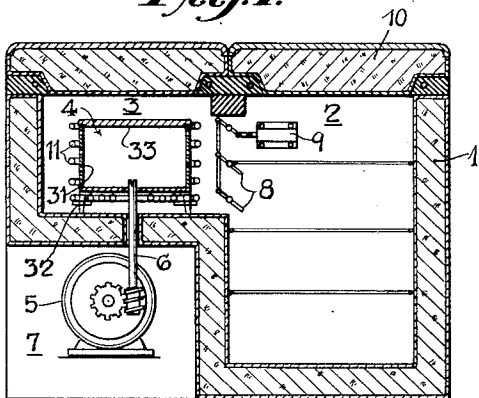

Fig. 2.

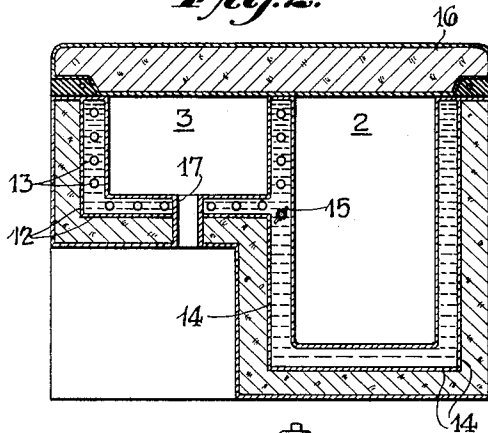

Fig. 3.

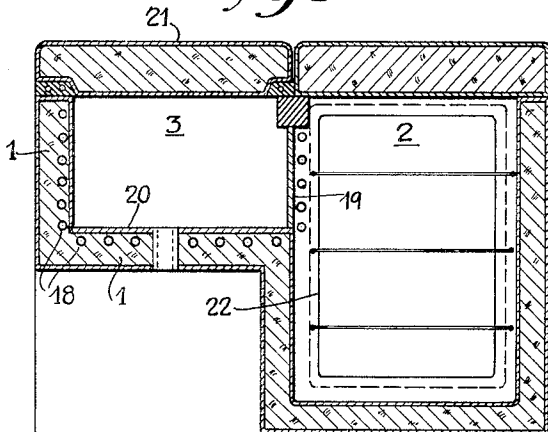

Fig. 4.

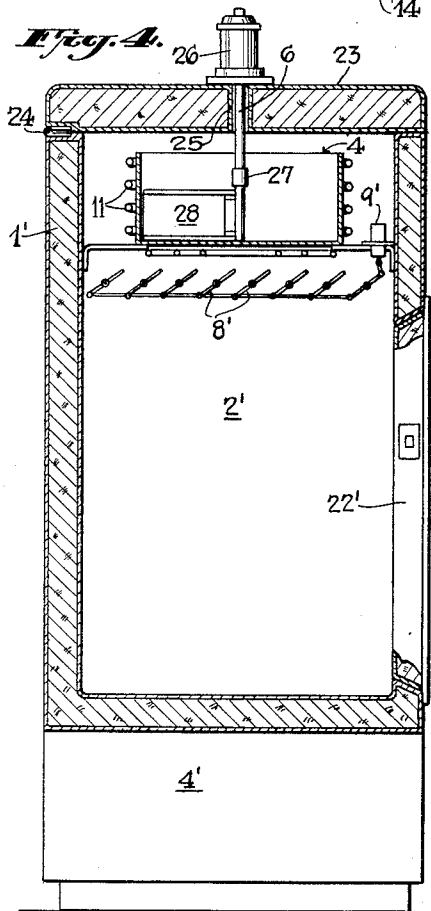

Fig. 5.

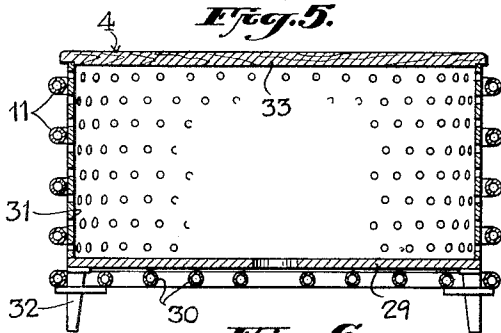
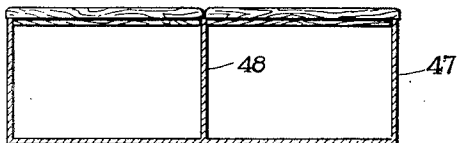

Fig. 6.



INVENTOR.

BERNHARD KATZENBERGER.

BY

K. A. May

ATTORNEY.

Nov. 10, 1953

B. KATZENBERGER

2,658,355

REFRIGERATOR AND DEEP FREEZER SYSTEM

Filed Nov. 15, 1950

3 Sheets-Sheet 2

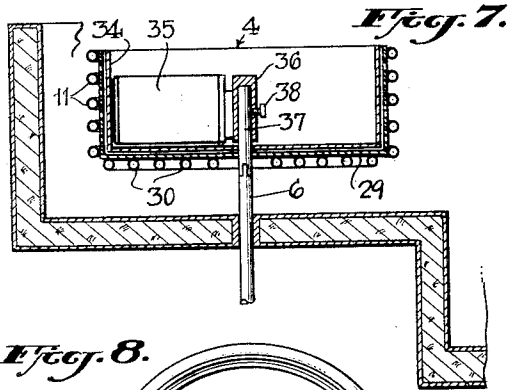

Fig. 7.

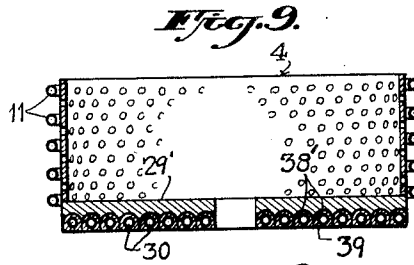

Fig. 9.

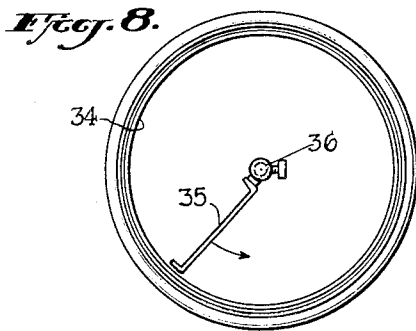

Fig. 8.

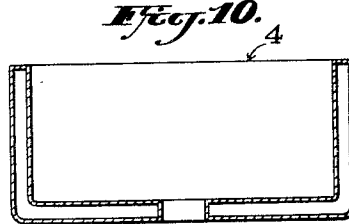

Fig. 10.

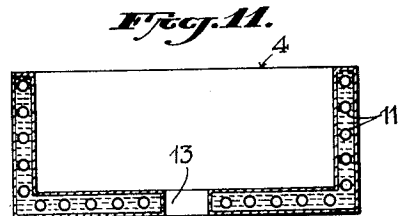

Fig. 11.

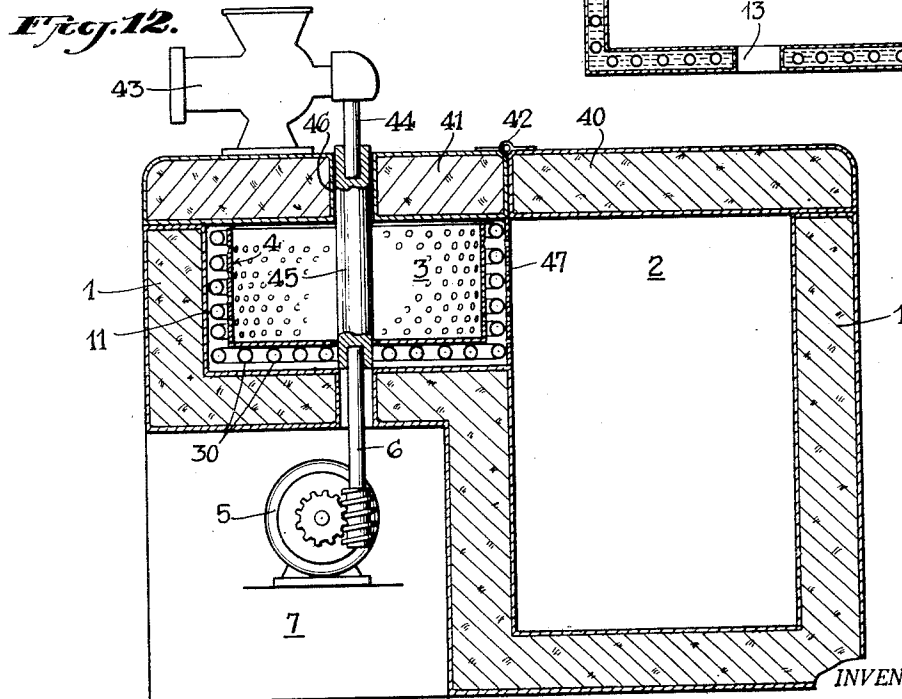

Fig. 12.

INVENTOR.
BERNHARD KATZENBERGER.
BY
H. A. Mays
ATTORNEY.

Nov. 10, 1953

B. KATZENBERGER

2,658,355

REFRIGERATOR AND DEEP FREEZER SYSTEM

Filed Nov. 15, 1950

3 Sheets-Sheet 3

Fig. 13.

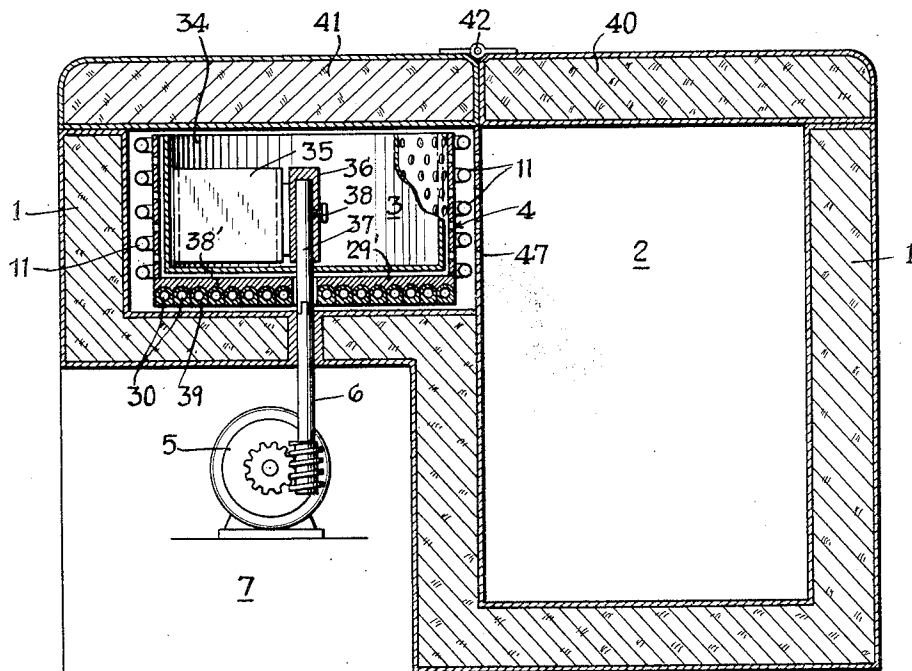

INVENTOR.
BERNHARD KATZENBERGER.
BY *H. A. Mays*
ATTORNEY.

UNITED STATES PATENT OFFICE

2,658,355

REFRIGERATOR AND DEEP FREEZER SYSTEM

Bernhard Katzenberger, Heidelberg, Germany,
 assignor to Brown, Boveri & Cie., Aktiengesellschaft,
 Mannheim-Kafertal, Germany, a corporation of Germany

Application November 15, 1950, Serial No. 195,857

Claims priority, application Germany
 November 18, 1949

5 Claims. (Cl. 62-99)

1

The present invention refers to refrigerators having at least two chambers which are operated at different temperatures.

Conventional refrigerators for household or commercial purposes are limited to one particular use only: they are either household ice boxes, commercial refrigerating chambers, deep freezers, or are made exclusively for making ice cream or for other individual purposes.

It is an object of the present invention to provide systems which can be used for a plurality of different purposes involving refrigeration.

The systems according to the invention comprise a deep freezing chamber which is accessible from above and surrounded by cooling elements in which a refrigerant evaporates and from which is derived the cold required in an adjacent chamber in which the temperature is higher than in the deep freezing chamber. An apparatus according to the invention is suitable, for example, for short-time storage and conservation at temperatures above zero of quickly perishable food-stuffs, as well as for freezing food such as meat, poultry, fruit, vegetables, liquids, etc., at below zero temperature. It is also suitable for producing ice cream, ice cubes, quick cooling of liquids, mixing and simultaneously cooling liquids, etc.

A further object of the invention resides in the provision of improved arrangements of the cooling chambers, of the cooler, of the drive mechanisms for mixers, agitators, and the like, and in the provision of controls for air circulation and temperature in the refrigeration and deep freezing chambers.

Further and other objects of the present invention will be hereinafter set forth in the accompanying specification and claims, and shown in the drawings which, by way of illustration, show what I now consider to be preferred embodiments of my invention.

In the drawings:

Fig. 1 is a diagrammatic sectional elevational view of a refrigerator system according to the invention;

Fig. 2 is a diagrammatic sectional elevational view of a modified refrigerator system according to the invention;

Fig. 3 is a diagrammatic sectional elevational view of a further modification of a refrigerator system according to the invention;

Fig. 4 is a diagrammatic sectional elevational view of yet another modification of a refrigerator system according to the invention;

Fig. 5 is a diagrammatic sectional elevation of

2

a cooler and deep freezing chamber forming part of the refrigerator systems according to the invention;

Fig. 6 is a diagrammatic sectional elevation of an insert for a cooler and deep freezing chamber according to the invention;

Fig. 7 is a diagrammatic elevational sectional view of a mixer inserted in a cooler and deep freezing chamber according to the invention;

Fig. 8 is a diagrammatic plan view of the mixer shown in Fig. 7;

Fig. 9 is a diagrammatic elevational sectional view of a modified cooler for use in the refrigerator systems according to the invention;

Fig. 10 is a diagrammatic elevational sectional view of a further modification of a cooler for use in the refrigerator systems according to the invention;

Fig. 11 is a diagrammatic elevational sectional view of yet another modification of a cooler for use in the refrigerator systems according to the invention;

Fig. 12 is a diagrammatic sectional elevational view of a modification of a refrigerator system according to the invention whose top is adapted to serve as a work table;

Fig. 13 is a diagrammatic vertical sectional view of a further modification of the invention.

Like parts are designated by like numerals in all figures of the drawings.

In the embodiment of the invention illustrated in Fig. 1 of the drawings, an insulated casing 1 is divided into two chambers 2 and 3. The latter contains a cooler 4 for cooling the chamber 3 to below zero.

A conventional refrigerating plant, not shown, and a motor 5 driving a shaft 6 extending into chamber 3 for operating a stirrer or agitator, which is known per se and does not form part of the invention and is therefore not shown, are disposed in space 7 below chamber 3. Cooler 4 serves also for cooling chamber 2. Chambers 2 and 3 are separated by adjustable air throttle means, such as baffles or shutters 8, the position of which may be automatically controlled by a thermostat 9 for maintaining a desired temperature in chamber 2. The top of the latter is closed by an insulated cover 10, making chamber 2 accessible from above. Of course, a door may be provided in a side wall without departing from the scope of the invention. Chamber 3 is also closed by a removable insulated cover. The top of one or both covers may be provided with a hard surface to serve as a table. Cooler 4 is surrounded by conduits 11 for the refrigerant and

so positioned in chamber 3 as to permit circulation of air from chamber 2 around the cooler.

Cooler 4 is shown in larger scale in Fig. 5. It is preferably cylindrical, although it may be angular or oval if desired, and comprises a flat bottom plate 29 on the lower side of which is a cooling coil 30 which continues as a cylindrical cooling coil 11. The latter may be protected on the inside by a perforated sheet 31 against damage when the container formed by the cooler is filled. Plate 29 has an aperture in the center for accommodating shaft 6 and may be supported by legs 32 which are adapted to support also the coil 30. The chamber formed by cooler 4 may be covered by a removable lid 33.

Cooler 4 is intended for storing foods requiring a temperature below zero, for freezing victuals, such as meat, poultry, fruit, and vegetables, as well as for making ice cubes. A container 47 having a partition 48 for sub-dividing it into a plurality of separate receptacles as shown in Fig. 6 may be inserted in cooler 4.

Figs. 7 and 8 illustrate diagrammatically a mechanism adapted to be inserted in cooler 4 for making ice cream, and for mixing and simultaneously cooling liquids. A drum 34 is placed on the bottom plate 29. Inside the drum is a conventional agitator or stirrer 35 having a hub portion 36 which is slipped over a shaft 37 and tightened thereon by a screw 38. The lower end of shaft 37 protrudes from the bottom of drum 34 so far as to also extend through plate 29 and coil 30 and is coupled to the top of shaft 6 (Fig. 1). Shaft 37 is preferably made of material of low heat conductivity. This device can be used in connection with all illustrated arrangements.

In the modification of cooler 4 which is shown diagrammatically in Fig. 9, the bottom coil 30 is laid in recesses 38' provided in the lower side of plate 29'. The part of the recesses not taken up by the pipes 30 is filled with material 39 having good heat conductivity. This modification of the deep freezing chamber can be used with all arrangements shown in the drawings.

The walls of the cooler 4 may be made hollow as shown in Fig. 10, and the refrigerant may be evaporated therein instead of in cooling pipes. Alternatively, cooling pipes 11' may be accommodated inside the hollow walls and the space left may be filled with eutectic brine. This is shown in Fig. 11.

In the modification of a refrigerator system shown in Fig. 2, chamber 3 comprises a jacket 12 lining the side and bottom walls of the chamber and separating it from chamber 2. The jacket is filled with eutectic brine which is cooled or frozen by refrigerant evaporating in pipes 13 disposed inside the jacket. The latter communicates with a jacket 14 lining the side and bottom walls of chamber 2. For controlling circulation and temperature of the brine in jackets 12 and 14, throttle means are provided such as a damper 15. The top of both chambers 2 and 3 is closed by a removable cover 16. An aperture 17 extends through the bottom wall and the adjacent jacket of chamber 3 for accommodating a drive shaft such as is designated by numeral 6 in Fig. 1.

In the embodiment of the invention illustrated in Fig. 3, cooling pipes 18 are embedded in portions of the insulating casing 1 forming the side and bottom walls of chamber 3 and are disposed adjacent to a wall member 19 separating chambers 2 and 3. The inside bottom of

chamber 3 is covered by a hard surface panel 20. The top of chamber 3 is closed by a removable cover 21. Chamber 2 is accessible from the front through a door 22 and cooled by the cooling conduits adjacent to wall portion 19.

Fig. 4 shows an arrangement in which the deep freezing cooler 4 is constructed as a container similarly to the one shown in Fig. 1, cooling pipes 11 being disposed adjacent to the bottom and side walls. The cooler is disposed in the upper part of a container 1' and separated from the lower part of the container by air flow throttling means shown as shutters 8'. The shutters are operated by a thermostat 9'. The container of cooler 4, as well as the top part of the interior of container 1', are accessible through a lid 23 which is hinged at 24 to container or casing 1'. Chamber 2' in the lower part of casing 1' is accessible through door 22'. An engine compartment 4' is arranged below the chamber 2'. Lid 23 has an aperture 25 for receiving a shaft 6 extending down from a motor 26 and adapted to be coupled at 27 to the shaft of an agitator or stirrer 28 for making ice cream or liquid mixes. The motor with the shaft 6 can be removed from cover 23 and aperture 25 may be closed by a plug.

Fig. 12 illustrates a combined refrigerator and deep freezer according to the invention which is adapted for additional use. It comprises a heat insulating casing 1 divided into chambers 2 and 3 in the same manner as in the modification according to Fig. 2, chamber 2 being used at temperatures above zero and chamber 3 at temperatures below zero. Each chamber is provided with an individual cover, 40 for chamber 2 and 41 for chamber 3, both covers being connected by a hinge 42. Cover 41 serves as a work table for supporting food processing machines, such as a meat grinder 43, and is provided with drive means adapted to be coupled to the food processing machines and comprising a downwardly extending drive shaft 44.

The latter can be coupled to shaft 6, which is driven by motor 5, by means of an intermediate shaft or coupling member 45 made of a material having low heat conductivity and extending through chamber 3 and apertures 46 in cover 41. Chamber 3 is surrounded by cooling pipes 30 and 11, and its inside is constructed substantially like the cooler illustrated in Fig. 5, an additional perforated plate 47 being provided on the side facing chamber 2. It may also be constructed in the manner illustrated, in Figs. 9 to 11. If the construction according to Fig. 11 is chosen, a jacket may be provided on the inside walls of chamber 2 as shown in Fig. 2.

Fig. 13 illustrates an arrangement of the type shown in Fig. 12, the container, however, being constructed as shown in Fig. 9 and a drum having agitating means therein as shown in Fig. 7 being inserted in the container.

While I believe the above described embodiments of my invention to be preferred embodiments, I wish it to be understood that I do not desire to be limited to the exact details of design and construction shown and described for obvious modifications will occur to a person skilled in the art.

I claim:

1. A two-temperature refrigerator comprising a heat exchange apparatus having tubular heat exchange conduits, a deep freezing chamber and a refrigerating chamber adjacent to said deep

5

freezing chamber, the latter being formed by a container having an open top, side walls all around, and a bottom plate, said conduits extending all around said container at the outside of said side walls and adjacent to said bottom plate outside of said container, a drum inserted in said container, agitating means in said drum, and a shaft extending through said bottom plate and into said drum and being connectable with said agitating means.

2. A combined refrigerator and deep freezer comprising at least two refrigeration chambers operated at different temperatures, one of said refrigeration chambers serving as deep freezing chamber constructed as a container accessible from above and surrounded by a cooling unit common to and cooling both chambers, said unit being constructed in the form of a tubular coil evaporator, the bottom of said deep freezing chamber being a flat plate equipped at its bottom surface with spiral recesses for the evaporator coils.

3. A combined refrigerator and deep freezer comprising at least two refrigeration chambers operated at different temperatures, one of said refrigeration chambers serving as deep freezing chamber constructed as a container accessible from above and surrounded by a cooling unit common to and cooling both chambers, said unit being constructed in the form of a tubular coil evaporator, the bottom of said deep freezing chamber being a flat plate equipped at its bottom surface with spiral recesses lined with heat-conducting material around the evaporator coils.

4. A combined refrigerator and deep freezer comprising at least two refrigeration chambers operated at different temperatures, one of said refrigeration chambers serving as deep freezing

6

chamber constructed as a container accessible from above and surrounded by a cooling unit common to and cooling both chambers, said unit being constructed in the form of a tubular coil evaporator, the bottom of said deep freezing chamber being a flat plate having an aperture in the middle and being equipped at its bottom surface with spiral recesses lined with heat-conducting material around the evaporator coils.

5. A combined refrigerator and deep freezer as defined in claim 4, said deep freezing chamber having a bottom plate to receive the evaporator coils embedded in heat-conducting material, the outside walls of said deep freezing chamber having attached to them, in a suitable manner, additional evaporator coils running helically.

BERNHARD KATZENBERGER.

References Cited in the file of this patent

UNITED STATES PATENTS

Number	Name	Date
Re. 22,976	Dailey -----	Feb. 24, 1948
1,879,922	Copeman -----	Sept. 27, 1932
1,916,746	Swisher -----	July 4, 1933
2,012,308	Heitman -----	Aug. 27, 1935
2,168,537	Pierce -----	Aug. 8, 1939
2,190,995	Phillip -----	Feb. 20, 1940
2,444,489	Baker -----	July 6, 1948
2,446,686	Behrens -----	Aug. 10, 1948
2,511,851	Iwashita -----	June 20, 1950
2,548,608	Janos -----	Apr. 10, 1951

FOREIGN PATENTS

Number	Country	Date
127,615	Switzerland -----	Sept. 1, 1928