

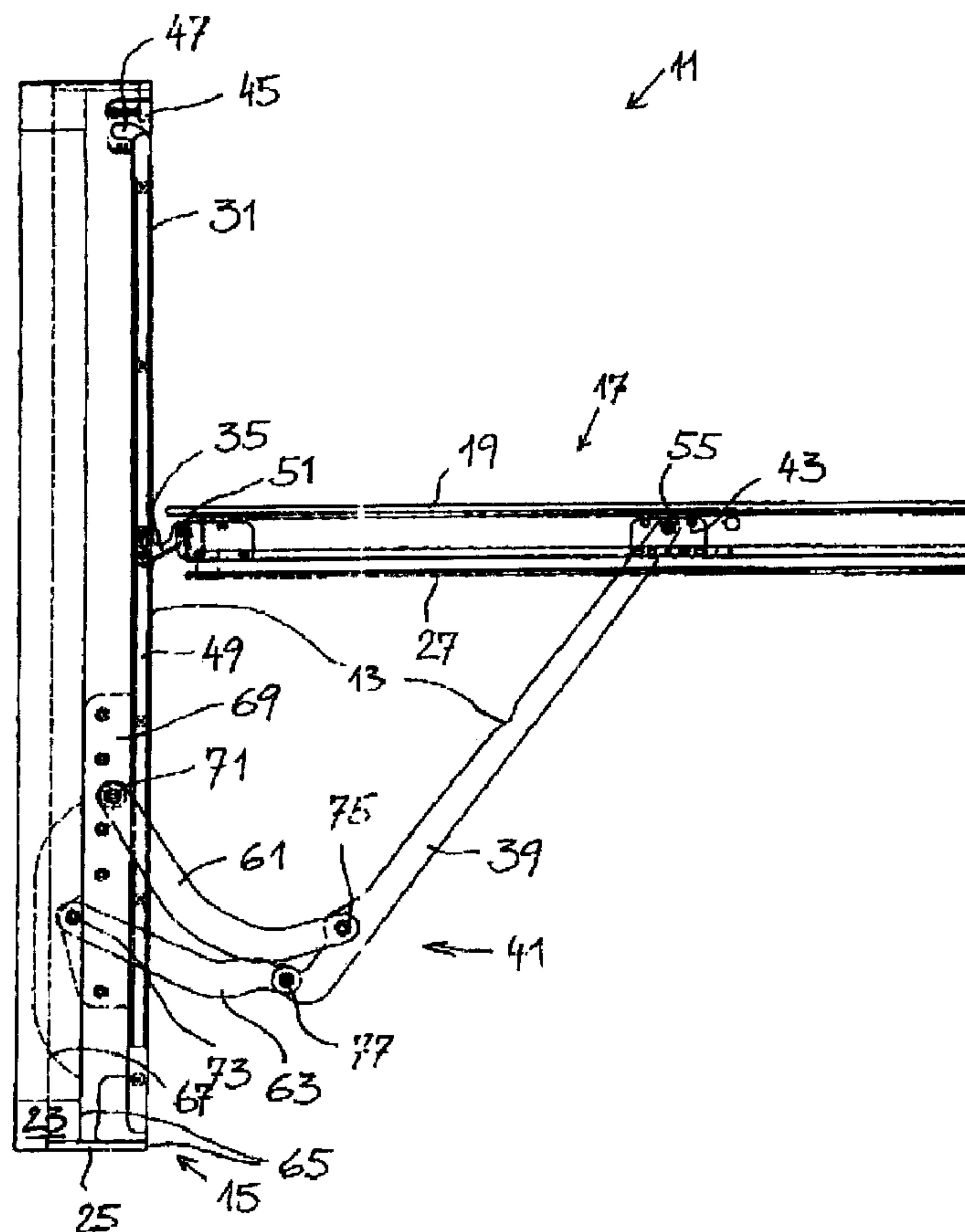

(86) Date de dépôt PCT/PCT Filing Date: 2005/10/20
 (87) Date publication PCT/PCT Publication Date: 2006/04/27
 (85) Entrée phase nationale/National Entry: 2008/04/18
 (86) N° demande PCT/PCT Application No.: CH 2005/000616
 (87) N° publication PCT/PCT Publication No.: 2006/042438
 (30) Priorités/Priorities: 2004/10/20 (CH1737/04);
 2005/04/14 (CH673/05)

(51) Cl.Int./Int.Cl. *E05D 15/44* (2006.01)
 (71) Demandeur/Applicant:
 WALCH AG, LI
 (72) Inventeurs/Inventors:
 WALCH, CHRISTIAN, AT;
 KOHLER, DIETMAR, AT
 (74) Agent: KIRBY EADES GALE BAKER

(54) Titre : FERRURE POUR FENETRE BATTANTE
 (54) Title: FITTING FOR A TURNING WINDOW



(57) Abrégé/Abstract:

The invention relates to a fitting for a turning window and to the turning window comprising a fitting. The turning window (11) comprises a frame (15) and a window leaf (17) which can be turned in relation to the frame (15). In order to turn the window wing

(57) **Abrégé(suite)/Abstract(continued):**

(17), the first end thereof can be displaceably mounted along the frame (15) which can be displaced from a closing position of the window leaf (17) on a first end of the frame (15) into an open position from the first end of the frame (15). The window leaf (17) is supported by an adjustment plate (41) which is at least approximately in equilibrium. The fitting (13) comprises a frame guiding rail (31) which is secured to the frame (15), a displacement part (35) which can be guided by the guiding rail (31) from the closed position until the open position. The displacement part is articulated in a pivotable manner to one end of the window leaf (17) about the displaceable axis (51). The first side of the adjustment plate (41) is formed by an arm (39) which is articulated with a balance axis (55) on the window leaf (17). The second side is formed by two equidirectional pivotable levers (61, 63) which are articulated on an arm (39) by means of two jointed axes (75, 77) which are arranged at a distance from each other. Said pivotable levers are articulated by means of two articulated axes (71, 73) on points on the frame (15), said points being arranged at a distance from each other. In said type of turning windows, the pivotable lever (61, 63) extends from the jointed axes (75, 77) to the articulated axes (71, 73) and also the arm (39) extends from the jointed axes (75, 77) to the balance axes (55) in the direction to the closing position of the displacement part (35).

ABSTRACT

The invention relates to a fitting for a turning window and to the turning window comprising a fitting. The turning window (11) comprises a frame (15) and a window leaf (17) which can be turned in relation to the frame (15). In order to turn the window wing (17), the first end thereof can be displaceably mounted along the frame (15) which can be displaced from a closing position of the window leaf (17) on a first end of the frame (15) into an open position from the first end of the frame (15). The window leaf (17) is supported by an adjustment plate (41) which is at least approximately in equilibrium. The fitting (13) comprises a frame guiding rail (31) which is secured to the frame (15), a displacement part (35) which can be guided by the guiding rail (31) from the closed position until the open position. The displacement part is articulated in a pivotable manner to one end of the window leaf (17) about the displaceable axis (51). The first side of the adjustment plate (41) is formed by an arm (39) which is articulated with a balance axis (55) on the window leaf (17). The second side is formed by two equidirectional pivotable levers (61, 63) which are articulated on an arm (39) by means of two jointed axes (75, 77) which are arranged at a distance from each other. Said pivotable levers are articulated by means of two articulated axes (71, 73) on points on the frame (15), said points being arranged at a distance from each other. In said type of turning windows, the pivotable lever (61, 63) extends from the jointed axes (75, 77) to the articulated axes (71, 73) and also the arm (39) extends from the jointed axes (75, 77) to the balance axes (55) in the direction to the closing position of the displacement part (35).

Fitting for a pivoting window

5 The invention relates to a fitting for a pivoting window and to a pivoting window comprised of a fitting. This fitting is provided for a pivoting window with a window frame and casement that can be rotated in relation to the window frame. In order to rotate the casement, its first end is displaceably mounted along the window frame, which can be displaced from a closing position of the casement to an initial end of the window frame into an open position
10 from the initial end of the window frame. The casement is supported by a bracket which is at least approximate in balance.

Prior art:

A fitting according to the preamble of independent claim 1 for said pivoting window is known
15 from NO 107 278 B. This known fitting for a pivoting window of the initially stated type contains a guiding rail designed on the window frame, a sliding part guided by the guiding rail from the closing position at an initial end of the guiding rail to the open position. One end of the casement is articulated in a pivotable manner to the guiding rail around a sliding axis that can be slid along the guiding rail, and a double-blade bracket. The first leg of the
20 bracket is formed by an arm which is articulated on the casement with a balancing axis. The second leg is formed by two parallel aligned pivoted levers, which are articulated on the arm by means of two joint axes, which are arranged at a distance from one another, and on the window frame by means of two articulation axes, which are also arranged at a distance from one another.

25

The guiding rail runs on the internal side of the pivot positions of the pivoted levers across the same height of the window frame. The arm is about half as long as the first pivoted lever. The second pivoted lever is about half as long as the arm. Both pivoted levers are positioned behind one another in longitudinal direction in closed or rotated position. The
30 distance between both joint axes is larger than the length of the second pivoted lever. Both the pivoted levers from the joint axes to their articulation axes, as well as the arm from the joint axes to the balancing axis extend in the direction of the rotating position of the sliding part.

Said fittings have the advantage of being provided between the window frame and the protection blind in a very space-saving manner when the window is closed. The balancing axis is kept at practically a constant height when opening and closing the window in order
5 for the casement to be simply pivoted and slid outward. This means that the operation of the casement requires little effort and that the casement can be made to rotate. Said fitting allows for the window to be rotated by 180 degrees.

This fitting was further developed. A fitting of the same type is described in Norwegian
10 patent application NO 2,180/70, in which the arm and the first pivoted lever are about equal in length. Both pivoted levers are positioned at a joint level in a known manner and vertical in relation to the window level. However, these are not placed one after another in longitudinal direction as opposed to NO 107 278B but rather side by side. These are secured to the window frame by means of a joint fastening plate and extend, while in closed
15 position of the window, to an essential part of its length parallel to one another.

However, these fittings have the disadvantage that current requirements with respect to the density of windows cannot be fulfilled. When opening the casement, its upper half reaches in between both brackets. As a result, it is out of the question to provide for a rabbet on the
20 window laterally overlaying the wing, which could be resting against the window frame in a sealing manner. Hence, the fitting must be located between the casement and window frame on the opening side of a seal.

Furthermore, the fitting has the disadvantage that the casement is simply brought closer to
25 the window frame with its upper edge from the bottom and parallel to the level of the window frame when it's being closed. Hence, it's not possible to press the wing circumferentially onto the window frame from the outside. This does prohibit or hamper such a sealing of the wing in relation to the window frame to satisfy the current requirements.

30 Task of the invention:

Hence, it's the task of the invention to create a window fitting which allows for a casement to be displayed or rotated around a horizontal pivoting axis with little effort. Tasks of preferred...

executions of the invention consist of developing the fitting and pivoting window comprised of a fitting in such a way that the casement can be sealed circumferentially at two levels at a distance from one another in relation to the window frame, and that a seal of the casement can be put vertical to the window level by means of pressing in relation to the window frame.

5

Description of the invention:

According to the invention, this task is solved in the case of a fitting according to the preamble of claim 1 and/or in the case of a pivoting window according to the preamble of claim 26 by the fact that both the pivoted levers extend from the joint axes to their
10 articulation axes and also the arm extends from the joint axes to the balancing axis in the direction of the closing position of the sliding part.

This means that the bracket is angled reversely in relation to the fitting according to NO 107 278B. In other words, the arm that is designed as a bracket serves as a support arm
15 according to the invention. The first upper pivoted lever is advantageously articulated between the joint axis of the second pivoted lever and the balancing axis on the arm. The second lower pivoted lever is articulated terminally on the arm. When opening the casement, its lowering upper end approaches the ends of the pivoted levers which are articulated on the window frame. Said end of the first pivoted lever is the first part of the
20 fitting, which reaches to the other side of the pivoting window level. Said ends of the pivoted levers, which are articulated on the window frame, merely reach the side that is faced outward in closed position when opening the pivoting window level. All other parts of the fitting remain on the same side of the window level during any manipulation of the casement. This guarantees a lot of freedom with respect to the lateral design of the
25 casement. The latter can for instance reach laterally beyond the fitting with the glass and can be attached to the window frame.

The described bracket allows for the casement to be displayed with little effort and for the center of gravity of the casement to be support while the upper end of the casement slides
30 from top to bottom of from bottom to top.

When lowering the first end of the casement past the fastening positions of the fitting on the window frame, ...

parts of the fitting forcefully reach the other side of the window level. These parts, namely the ends of the pivoted levers that are articulated on the window frame, are positioned
5 beyond the edge of the window when the guiding rail reaches between both legs of the bracket. Hence, the initial end of the casement and the sliding part, respectively, can be guided past the articulation axis of the first pivoted lever without coming into conflict with said articulation axes thanks to said arrangement of the guiding rail. This design, compared to the arrangement of the guiding rail on the side of fitting turned away from the casement,
10 has the disadvantage that the window cannot be entirely rotated. However, it does feature the advantage that a rabbet can be designed on the casement with which the casement can rest tightly against the window frame on the wing-side of the fitting. Consequently, the fitting can be assembled within a seal area.

15 Advantageously, the first pivoted lever is crescent-shaped. The crescent shape allows for the sliding part to clear the longest possible sliding path between the legs of the bracket. This crescent shape allows therefore for the window to be rotated by up to approximately 165 degrees. This is of particular significance to clean the exterior of the window.

20 A compactly collapsible bracket with an extensive scope of action is enabled as the form of the pivoted levers and the position of the articulation axes and joint axes are selected in such a way that the first pivoted lever has to be pivoted away over the articulation axes of the second pivoted lever on the window frame when changing between the closing and open position of the fitting.

25 The second pivoted lever is advantageously shorter than the first pivoted lever. Preferably, the first pivoted lever is maximum half as long as the arm. The second pivoted lever is advantageously longer than a third of the arm. In the case of an advantageous arrangement of the axes, the distance between the articulation axes (articulation of the pivoted levers on
30 the window frame) is larger than the distance between the joint axes (joint between pivoted levers and arm).

As for a compact solution of the fitting, both pivoted levers are advantageously arc-shaped. These pivoted levers can grasp around the first end of the pivoted casement and around the
35 sliding part, respectively, thanks to said shape. This does not only allow for the casement to be rotated by about 180 degrees...

but also for a circumferential rabbet, which attaches to the window frame outside the fitting in closed position, to be designed on the casement and hence also on the first side of the casement. Advantageously, the first pivoted lever is designed in the shape of an arc so that the elbow, with which the pivoted lever connects to the stretched arm, is larger than the elbow between the arm and a straight line connecting the joint axis and articulation axis of the first pivoted lever.

10 The arm is articulated on a fastening plate with the balancing axis for the sake of a simple assembly. The fastening plate can for instance be fastened to the casement with screws.

When each of both pivoted levers can also be fastened to a separate fastening plate or directly to the window frame, this will be preferred when both pivoted levers are articulated on a joint fastening plate. Said plate can be fastened to the window frame and defines the exact geometry of the bracket.

Advantageously, the sliding part is designed as a lever. In the event that means are available on an initial end of the guiding rail to forcefully pivot the lever, which is slid against the closing position, in and/or to a sealed position pressed onto the window frame, this will have the advantage that the edge of the casement on said first end of the guiding rail can be firmly pressed against the window frame, while the lever is pivoted. While in the closed position, the frame is practically in an end position in longitudinal direction of the guiding rail. While in the sealed position, the frame from the closed position is additionally pressed against the window frame across the guiding rail.

Furthermore, this lever has the advantage that the first end of the casement turns away from the window frame when opening the wing and is guided at a distance from the guiding rail. As a result, this wing can have an overhang in relation to the pivoting area of the sliding axis on the window frame. This overhang allows for the design of a rabbet which can attach to the window frame from the outside. This overhang is kept at a distance from the window frame thanks to the lever. In order for the first end of the wing to be guided with the overhang against the window frame from the outside, it is...

required to pivot said lever in an end position. For this purpose, means have been provided
5 to forcefully cause this pivoting.

Advantageously, the lever is guided vertically along the guiding rail at a certain angle to the
guiding rail. The first end of the casement is therefore guided at a certain and consistent
distance from the window frame. When the lever can also be designed in a pivotable
10 manner in relation to the guiding rail, it will be preferred that it's positioned at a certain angle
to the guiding rail. This prevents the lever to be pivoted unintentionally and guarantees that
the distance of the wing to the window frame is practically constant irrespective of the
position of the opened window.

15 The means to forcefully pivot the lever can be formed by an arc segment of the guiding rail.
The lever will not need to be designed in a pivotable manner in relation to the guiding rail.
When the lever is posited at a certain angle to the guiding rail, it will be forcefully pivoted
when passing through the arc segment.

20 However, the lever can also be pivotable at least on the first end of the guiding rail with
respect to the guiding rail. The means to forcefully pivot the lever are advantageously built
with a stopper that collaborates with the lever and pivots the lever. Nevertheless, the lever
can be guided in a non-pivotable manner across the length of the guiding rail in relation to
the guiding rail. Two guidings can be present in the guiding rail which keep the lever stable
25 and which cause the lever to be pivoted in an end position.

The lever can feature an elongated guiding head. Advantageously, the lever shows two
guiding heads working together with the guiding rail. This gives it a defined adjustment to
the guiding rail. The lever is guided at a certain angle to the guiding rail thanks to points of
30 contact, which are arranged at a distance from one another, between the guiding head(s)
and the guiding rail. Hence, it can absorb power from the wing and carry it to the guiding rail
and is not pivoted due to this power.

Advantageously, the guiding rail is stretched between its end areas. However, the upper end area is preferably designed as arc segment.

5

For the purpose of designing the means to pivot the lever, an end part is advantageously connected to the first end of the guiding rail. The means to pivot the lever are created on this end part and can be easily assembled on the window frame or on the guiding rail.

10 Additionally, the means to pivot the lever are simply to be placed precisely in the right position on the window frame.

Advantageously, two such fittings are used in reversed image design for a pivoting window.

The invention also relates to a pivoting window comprised of an abovementioned fitting.

15 Said pivoting window features in a known way a window frame and a casement that can be set or rotated around a horizontal axis in relation to the window frame. The first end of the casement is displaceably positioned to rotate the casement from a closing position on a first end of the window frame to an open position away from the first end of the window frame. Such a displacement takes place along the window frame. In addition, the casement is
20 supported by a bracket approximately in balance.

This pivoting window is equipped with a fitting. This fitting contains a guiding rail fastened to the window frame, a sliding part guided by the guiding rail from the closing position to the open position, and a double-bladed bracket. The sliding part can be pivoted by a sliding axis
25 on an end of the casement. As for the bracket, the first leg is formed by an arm which is articulated on the casement with a balancing axis. The second leg is formed by two parallel aligned pivoted levers. These pivoted levers are articulated on the arm by two joint axes, which are arranged at a distance from one another, and on positions, which are arranged at a distance from one another, by two articulation axes on the window frame. The first pivoted
30 lever is advantageously articulated on the arm between the joint axis of the second pivoted lever and the balancing axis, and the second pivoted lever is advantageously articulated at the end of the arm.

The window according to the invention differs from the initially described prior art in that both the pivoted levers extend from the joint axes to their articulation axes and that the arm
5 extends from the joint axes to the balancing axis in the direction of the closing position of the sliding part. This arrangement of the bracket, in opposition to the prior art, has the previously mentioned advantages with respect to freedom of the lateral design of the casement.

10 The guiding rail is advantageous directed past the articulation axes on the side of the casement. The joint axis, by which the second pivoted lever and the arm are each articulated on their ends to one another, is moved over to the edge as wide as possible so that the sliding part can be slid as wide as possible along the guiding rail. The articulation axes of the pivoted levers are placed as deep as possible. The articulation axes are
15 advantageously placed in the lower third of the window height.

Additionally, an arc shape of the pivoted lever increases the sliding range for the sliding part until far against the edge of the window frame adjacent to the first end of the guiding rail. If the first pivoted lever is arc-shaped and a slot is created in the window frame, the convex
20 range of the pivoted lever can be arranged in this slot in closed position of the pivoting window. This slot allows for the pivoted lever to be placed between the casement and window frame beyond an internal sealing level without influencing the density of the window. Even the articulation axis of the second pivoted lever is advantageously placed inside the slot so that the geometry of the bracket is optimal and the depth of the window frame (the
25 dimension vertical to the window level) is kept as minor as possible.

This window design allows for the casement and the window frame to feature to circumferential sealing strips at two levels arranged at a distance from one another and it also allows for the sealing strips are attached to one another in the closed position and are
30 pressed against one another, respectively, in a sealed position. An elastic sealing lip can be provided on the window frame or casement.

The fitting is placed inside a crevice between the circumferential sealing strips in the closing position of said pivoting window with two sealing levels.

35

The fitting is thereby not only protected against dirt but does not create any essential thermal bridges either.

5

The fitting is advantageously placed on a profile creating a wing-sided area of the window frame. This profile is advantageously made out of synthetic material on thermotechnical grounds.

10 The guiding rail is advantageously designed directly in the profile. It can be exempted in an end area and supplemented by an end part which defines for instance an arc segment.

The window frame contains advantageously a frame made out of wooden slabs. A crosscut piece of the profile is fit on the exterior on each of the wooden slabs forming the frame. This
15 profile hangs over the wooden slab on the side of the casement. For the sake of simply fastening the profile to the wooden slab, the latter features at least a slot and the profile features at least a rib meshing with said slot.

The casement is advantageously attached to the window frame from the exterior by means
20 of a circumferential sealing strip. This sealing strip is advantageously located outside of the fastening positions of the fitting on the window frame and on the casement. A rabbet can be designed on the casement for this purpose. However, the casement features in a preferred embodiment a frame and tier vitrification laterally protruding above the frame. The rabbet and outer sealing strip is formed by the outer glass of the tier vitrification.

25

In order for the profile not to feature any notch for the articulation axes, the fastening plate for the pivoted levers is advantageously arched as such that the fastening plate is raised from the underground in the area of the articulation axes.

30 As for a fitting with a described guiding rail and displaceably positioned lever therein on which the upper end of a pivoting window sash should be articulated, a bracket has been designed featuring the following characteristics. The support arm carries a fastening plate on its outer end which can be fastened to the window sash. In any event, it is supplied in order to be articulated on the window sash. Hence, the support arm is directly articulated on
35 the window sash in the case of a pivoting window.

In order for the end of the support arm, which is articulated or is to be articulated on the casement, to perform an essentially straightforward and advantageously horizontal
5 movement when pivoting the support arm, the latter is equipped with two pivoted levers articulated on the support arm, which can be or are articulated on the window frame on its part. Said pivoted levers do not cross. The four pivoting axes (two joint axes and two articulation axes) form a variable square during the pivoting movement, the side lengths of which remain constant. However, the angles do not change between sides adjacent from
10 one another thanks to the fact that the side lengths of the four sides are variably long.

The joints in similarly known fittings are located between the pivoted levers and the simple arm above whereas the articulation points on the window frame and on the window sash are placed below. However, as for the bracket according to the invention, the pivoted levers
15 feature the joint axes formed between the support arm and the pivoted levers from the articulation axes formed between the window frame and the pivoted levers and placed in the lower third of the window frame. Accordingly, the support arm does not sink towards the outside but instead the support arm stretches from the joint axes located lower to the end of the support arm located higher, while supporting the casement. As a result, this bracket
20 does not come into conflict with the vertically displaceable lever on which the upper end of the window sash is articulated.

Advantageously, the lower pivoted lever is shorter than the upper pivoted lever. Furthermore, the distance between both pivoting axes, which are designed between the
25 window frame and pivoted levers, is larger than the distance between both pivoting axes, which are designed between the support arm and pivoted levers, in order to obtain the desired motion of the support arm.

In order for the window sash to be rotated as widely as possible, the pivoted levers have a
30 convex arc-shaped design up to the inside of the window. Hence, said levers can encompass the upper end of a rotated casement.

The bracket for propping a casement, just as is the case for known bracket, features a support arm to carry the casement, an initial pivoted lever near an end...

of the support arm (and closer to the casement than the second one) articulated and to be articulated on a window frame. Furthermore, a second pivoted lever is available which is articulated on this end of the support arm and is to be articulated on the window frame. The bracket described here differ from the known bracket by the fact that the first pivoted lever is half as long as the support arm. The bracket can be assembled in the window frame as opposed to the known ones thanks to said aspect ratios without the pivoted lever having to cross the sliding path of the sliding part after just a short sliding stretch. Hence, the bracket is V-shaped and is to be assembled on the window frame with an upward opening. The bracket is articulated in the lower third of the window frame thanks to the aspect ratios. This allows for the pivoting window to be rotated at least to such an extent until the upper end of the casement reaches the lower third of the window frame. Additionally, the bracket allows for the fact that the casement overlaps the bracket laterally since the support arm and pivoting arms always remain on the interior of said overlapping window frame rabbets when rotating and closing the casement in relation to the window frame.

Advantageously, the first pivoted lever is arc-shaped so that the angle, at which the pivoted lever connects to the support arm, is larger than the angle between the support arm and a straight line connecting the pivoting axes of the pivoted lever. Consequently, the upper end of the casement can be moved far down of the pivoting axes of the first pivoted lever on the window frame. The arc-shaped pivoted lever encompasses thereby the upper end of the casement.

The second pivoted lever is advantageously shorter than the first pivoted lever, however, it's longer than a third of the support arm. As a result, this produces a somewhat horizontal motion of the outer end of the support arm, which is clearly located above the pivoting axes of the pivoted levers.

In the case of a pivoting window comprised of a window frame and a pivotable casement, the latter is, as is generally known, displaceably positioned on the upper end in a guiding rail vertically guided along the window frame. The casement is supported by a bracket. For this purpose, the bracket contains two pivoted levers articulated on two pivoting axes on the window frame, and one support arm articulated on the pivoted levers. The support arm is articulated on the casement in a central area.

Unlike the known pivoting windows, the guiding rail passes over the pivoting axes arranged on the window frame in the proposed pivoting window on the side of the casement, and it is V-shaped and has an opening facing upward. The upper part of the casement can be moved beyond the pivoting axes into the opening of the V-shaped, open bracket thanks to this design. In the event that the pivoted levers, or at least the pivoted levers closer to the casement, are arc-shaped, the opening of the V-shaped fitting will be enlarged as such that the upper end of the casement can be lowered even further. This arc-shaped design of the pivoted levers requires that the pivoted lever demands more space than what is available between window frames and casements. That's why a slot is created in the window frame in which in closed condition of the window, the convex area of the pivoted levers, which are closer to the casement and arc-shaped, is placed.

15 Short description of the figures:

Figures 1 to 4 show schematic representations, partially cut, of an embodiment of a pivoting window with the casement in varying pivoting positions.

Figure 1 shows the casement in a horizontal position in which support arm 39 features the largest overhang.

20 Figure 2 shows casement 17 in an extreme pivoting position in which the window exterior is turned inward.

Figure 3 shows the casement in a slightly opened position (ventilation position).

Figure 4 shows the casement in the closed position.

25 Figure 5 shows a perspective sectional drawing through a further development of the window according to figures 1 to 4.

Detailed description of the figures:

30 Figures 1 to 4 display an embodiment of a pivoting window 12 comprised of a fitting according to the invention. The figures show the cut window frames 15 so that the setup of the window frame from wooden slab 23 and soffit board 25 is visible. The view is directed towards the interior of the adjacent soffit of window frame 15. Bracket 41 and guiding rail 31 are placed on this interior of soffit board 25.

Furthermore, casement 17 is visible with window sash 27 and glass 19. Casement 17 is shown in different positions in the figures. Figure 1 shows the casement in a horizontal position in which support arm 39 features the largest overhang. Figure 2 shows casement 17 in an extreme pivoting position, in other words, the window exterior is turned inward. Figure 3 shows the casement in a slightly opened position (ventilation position). Figure 4 shows the casement in the closed position.

10 Casement 27 is propped by bracket 41. The pivoting window fitting 13 contains a guiding rail 31 and a lever 35 (fig. 1) displaceable positioned therein on two rolls 33. The first (upper) end of the window frame is displaceably positioned on said lever 35 by a displaceably sliding axis 51. Guiding rail 31 consists of an end part 45 on its first (upper) end with an arc segment 47 and a stretched vertical segment 49 connected thereto along the outer edge of soffit board 25.

The bracket 41 features an arm designed as support arm 39 that is articulated on fastening plate 43, which is placed on window sash 27, with a first (outer) end. Fastening plate 43 is placed somewhat above the middle, in other words, in a lower area of the upper window half on the casement. The second end of support arm 39 is connected with window frame 15 on the side of the window frame through two pivoted levers 61, 63, which are arranged at a distance from one another. The first pivoted lever 61 is articulated on window frame 15 above the second pivoted lever 63 and at a short distance from the second end of support arm 39. The second (lower) pivoted lever 63 is articulated on window frame 15 inside wooden slab 23 of window frame 15, in other words, behind the level defined by sealing strip 65 on wooden slab 23. Window sash 27 rests tightly against wooden slab 23 of the window frame in the sealed position of the casement as made possible with circumferential sealing strip 65.

30 Both pivoted levers 61, 63 are arc-shaped so that casement 17 can be maximally turned (fig. 2). The fitting according to the invention allows for the window to be pivoted by approx. 165 degrees. The arc or crescent-shaped design of the pivoted levers requires that, for the most part, the pivoted levers are located within the level defined by sealing strip 65, which is placed on the wooden slab (fig. 4) while the window is closed.

A slot 67, which is milled in wooden slab 23, creates the necessary space for pivoted levers 61, 63 in the closed and sealed position.

5

A fastening plate 69 is available for a secure anchoring of the pivoted levers 61, 63 on the window frame. This fastening plate is connected to soffit board 25 and on which the position for the pivoted levers is designed. Both pivoted levers 61, 63 overlap one another. The lower pivoted lever 63 is located closer to soffit board 25 and the upper pivoted lever 61 is closer to the window sash (figures 1 to 3). Both pivoted levers 61, 63 are articulated on opposite sides of support arm 39 so that these pivot at levels arranged at a distance from one another.

10

The distance between the articulation axes 71, 73 of the pivoted levers 61, 63 on the window frame is larger than the distance between the joint axes 75, 77 of the pivoted levers 61, 63 on support arm 39. Furthermore, the lower pivoted lever 63 is shorter than the upper pivoted lever 61. Consequently, a pivoting of the pivoted levers 61, 63 is connected with an opening of the angle between window frame 15 and support arm 39 towards the outside. Balancing axis 55 between support arm 39 and window sash 27 practically moves horizontally and outward when the pivoted levers 61, 63 are pivoted.

20

Support arm 39 is pivoted outward when opening window 11, whereby both pivoted levers 61, 63 pivot along. As a result, the lower end of support arm 39 is raised and the angle between support arm 39 on the one hand and the pivoted levers 61, 63 on the other hand becomes increasingly larger. The maximum aperture angle of the support arm is achieved in the horizontal position of the window sash. The aperture angle between the support arm and window sash (depending on the height of the window and the selected fitting size) is equal to approx. 35 degrees. The pivoted levers 61, 63 pivot by about 55 degrees (first pivoted lever 61) and by about 70 degrees (second pivoted lever 63) when pivoting the window sash in the horizontal position.

25

Support arm 39 is again pivoted back when the upper end of window sash 17 is further lowered until, eventually, the window sash has rotated and is positioned with the exterior of the glass at a small angle of approx. 15 degrees before the opening of window frame 15. Support arm 39 is parallel to window frame 15 in closed position.

30

35

5 The upper end of window sash 17 is articulated on lever 35. The latter is displaceably positioned in guiding rail 31. The lever 35 is also pivoted outward by the compulsory guide of arc segment 47 of rail 31 due to the swiveling out of the window sash. At first, window sash 17 is raised by sealing strip 65 prior to guiding the upper end of the window sash vertically downward through the stretched segment 49 of guiding rail 31.

10 Essentially, bracket 41 can be placed within the window frame profile in the gap between window frame 15 and window sash 17. The frame profile is made out of wooden slab 23 and soffit board 25.

15 A profile out of synthetic material is provided in the embodiment displayed in figure 5 instead of soffit board 25 in opposition to the first embodiment. The guiding rail 31 is already designed in this profile 25. Hence, the fitting in this embodiment entails also this profile 25. That's why fitting 13 is also a component of window frame 15 in this embodiment variable. Profile 25 can be made out of synthetic material in order to have an advantageous thermal insulation value. It can for instance also be extruded from aluminum. However, extruded
20 synthetic profiles are also cost-efficient in manufacturing and already proven window construction.

Profile 25 is sticks together with wooden slab 23. The frame profile is made out of wooden slab 23 and profile 25.

25

A double seal is realized for both embodiments. Additionally, the seal of window sash 17 in relation to window frame 15 by pressing the casement 17 against window frame 15 in a direction vertical to the window level and to the seal levels.

30 An internal seal level is defined by sealing strip 65 on wooden slab 23 of the window frame. An outer seal level is defined by sealing strip 65 on the profile or on soffit board 25. Window sash 27 presses in sealed position against the inner sealing strip 65 and interior of the outer glass disc of the tier glass 19 against the front side of the profile or of soffit board 25.

Essentially, the front side is formed at least in profile 25 by guiding rail 31.

5

A space in which the overall fitting is arranged is located between both sealing strips 65. However, this space is expanded by slot 67 behind the interior seal level in wooden slab 23.

10

An elastic seal is advantageously provided in the area of the inner sealing strip on the window frame. A second elastic seal can be provided on the interior of the overhanging tier glass 19. These seals can also be designed on the respectively opposite part, namely on the interior of window sash 27 and on the front side of soffit board 25 or of profile 25.

Patent claims:

- 5 1. Fitting (13) for a pivoting window (11) with a window frame (15) and casement (17) that
can be rotated in relation to window frame (15), in which pivoting window (11), for the
purpose of rotating the casement (17), its first end is displaceably positioned from a
closing position of the casement (17) on an first end of the window frame (15) to an
open position of the first end of the window frame (15) along the window frame (15),
10 and the casement (17) is supported with a bracket (41) at least approximately in
balance;
the fitting (13) contains
- a guiding rail (31),
 - a sliding part (35) guided by the guiding rail (31) from the closed position at a first
15 end of the guiding rail (31) to the open position, for the purpose of articulating an
end of the casement (17) on the guiding rail (31) by a displaceable sliding axis
(51),
 - and a double-bladed bracket (41), for which bracket (41)
 - the first leg is formed by an arm (39), which is to be articulated on a first end
20 on the casement (17), which articulation defines a balancing axis (55), and
 - the second leg is formed by two parallel aligned pivoted levers (61, 63),
which are articulated on the arm (39) by two joint axes (75, 77) arranged at a
distance from one another, and which are to be articulated on the window
frame (15) on two positions at a distance from one another, which positions
25 define two articulation axes (71, 73),
- characterized by the fact
- that both the pivoted levers (61, 63) extend from the joint axes (75, 77) to their
articulation axes (71, 73) and that the arm (39) extends from the joint axes (75,
30 77) to the balancing axis (55) in the direction of the closed position of the sliding
part (35).
2. Fitting according to claim 1, characterized by the fact that the first pivoted lever (61) is
articulated on the arm (39) between joint axis (77) of the second pivoted lever (63) and
the...
- 35

the balancing axis, and that the second pivoted lever is terminally articulated on the arm (39).

5

3. Fitting according to claim 1 or 2, characterized by the fact that the guiding rail (31) reaches between both legs of bracket (41).

10

4. Fitting according to claim 3, characterized by the fact that the first pivoted lever (61) is crescent-shaped in order to clear the longest possible sliding path for the sliding part (35) between the legs of the bracket (41).

15

5. Fitting according to claim 4, characterized by the fact both pivoted levers (61, 63) are arc-shaped in order to encompass the first end of the rotated casement (17) and sliding part (35), respectively.

20

6. Fitting according to claim 4 or 5, characterized by the fact that the form of the pivoted levers (61, 63) and the position of the articulation axes (71, 73) and joint axes (75, 77) is selected in such a way that the first pivoted lever (61) has to be pivoted away across the articulation axis (73) of the second pivoted lever (63) on the window frame in case of a change between the closed position and open position of the fitting (13).

25

7. Fitting according to one of the claims 2 through 6, characterized by the fact that the second pivoted lever (63) is shorter than the first pivoted lever (61).

8. Fitting according to one of the claims 1 through 7, characterized by the fact that the distance between the articulation axes (71, 73) is larger than the distance between the joint axes (75, 77).

30

9. Fitting according to one of the claims 1 through 8, characterized by the fact that the arm (39) is articulated on a fastening plate (43) with the balancing axis (55), which is to be fastened to the casement (17).

35

10. Fitting according to one of the preceding claims, characterized by the fact that both pivoted levers (61, 63) are articulated on a...

joint fastening plate (69), which is to be fastened to a window frame (15).

- 5 11. Fitting according to claim 10, characterized by the fact that the fastening plate (69) for the pivoted levers (61, 63) is raised in an arched manner from the underground in the area of the articulation axes (71, 73).
- 10 12. Fitting according to one of the claims 1 through 11, characterized by the fact
- that the sliding part (35) is formed as a lever, and
 - that means (47) are available on a first end of the guiding rail (31) for the forceful pivoting of the lever (35) in and from a sealed position, respectively, slid against the closed position.
- 15 13. Fitting according to claim 12, characterized by the fact that the lever (35) is vertically guided along the guiding rail at a certain angle to the guiding rail (31).
- 20 14. Fitting according to claim 12 or 13, characterized by the fact that the means for the purpose of forcefully pivoting the lever (35) through an arc segment (47) of the guiding rail (31) are developed.
- 25 15. Fitting according to claim 12 or 13, characterized by the fact that the lever (35) is pivotable at least on the first end of the guiding rail (31) with respect to the guiding rail and that the means for the forceful pivoting of the lever (35) by a stopper collaborating with the lever (35) are developed.
- 30 16. Fitting according to one of the claims 12 through 15, characterized by the fact that the lever (35) features two guiding heads (33) working together with the guiding rail (31).
- 35 17. Fitting according to one of the claims 12 through 16, characterized by the fact that the guiding rail (31) extends between its end areas.
18. Fitting according to one of the preceding claims, characterized by the fact that an end part (45), which is subsequently arranged on the first end of the guiding rail (31),...

on which end part (45) the means (47) are developed to pivot the lever (35).

5

19. Fitting according to one of the preceding claims, characterized by the fact the first pivoted lever (61) is maximum half as long as the arm (39).
20. Fitting according to claim 19, characterized by the fact that the first pivoted lever (61) is arc-shaped as such that the angle with which the pivoted lever (61) connects to the stretched arm (39) is larger than the angle between the arm (39) and a straight line connecting one of the joint axes (75) and articulation axis (71) of the first pivoted lever (61).
21. Fitting according to claim 20, characterized by the fact that the second pivoted lever (63) is longer than a third of the arm (39).
22. Fitting according to one of the preceding claims, characterized by a profile (25) on which the pivoted levers (61, 63) are arranged, which profile forms an area of the window frame (15) on the side of the casement.
23. Fitting according to claim 22, characterized by the fact that the profile (25) is a profile made out of synthetic material.
24. Fitting according to claim 22 or 23, characterized by the fact that the guiding rail (31) is designed in the profile (25).
25. Fitting according to claim 24, characterized by the fact that the guiding rail (31) is exempted from the profile (25) in an end area and that the guiding rail (31) is supplemented at this position by an end part (45), particularly with an arc segment (47).
26. Pivoting window (11) with a window frame (15) and casement (17) that can be rotated in relation to the window frame (15), in which pivoting window (11), for the purpose of rotating the casement (17), its first end is displaceably positioned from a closing position of the casement (17) on an first end of the window frame (15) to an...

10

15

20

25

30

35

- 5 open position of the first end of the window frame (15) along the window frame (15),
and the casement (17) is supported with a bracket (41) at least approximately in
balance, comprised of a fitting which (13) contains
- a guiding rail (31),
 - a sliding part (35) guided by the guiding rail (31) from the closed position at a first
10 end of the guiding rail (31) to the open position, for the purpose of articulating an
end of the casement (17) on the guiding rail (31) by a displaceable sliding axis
(51),
 - and a double-bladed bracket (41), for which bracket (41)
 - the first leg is formed by an arm (39), which is to be articulated on a first end
15 on the casement (17), which articulation defines a balancing axis (55), and
 - the second leg is formed by two parallel aligned pivoted levers (61, 63),
which are articulated on the arm (39) by two joint axes (75, 77) arranged at a
distance from one another, and which are to be articulated on the window
frame (15) on two positions at a distance from one another,
characterized by the fact
- 20 - that both the pivoted levers (61, 63) extend from the joint axes (75, 77) to their
articulation axes (71, 73) and that the arm (39) extends from the joint axes (75,
77) to the balancing axis (55) in the direction of the closed position of the sliding
part (35).
- 25 27. Pivoting window according to claim 26, characterized by the fact that the guiding rail
(31) is passed over the articulation axes (71, 73) on the side of the casement (17).
28. Pivoting window according to claim 26 or 27, characterized by the fact that the first
30 pivoted lever (61) is articulated on the arm (39) between the joint axis (77) of the
second pivoted lever (63) and the balancing axis (55), and that the second pivoted
lever (63) is terminally articulated on the arm (39).
29. Pivoting window according to claim 28, characterized by the fact that the first pivoted
35 lever (61) is arc-shaped and that a slot (67) is created in the window frame (15), in
which the convex area of the...

of the pivoted lever (61) is arranged in closed condition of the pivoting window (11).

- 5 30. Pivoting window according to claim 29, characterized by the fact that the articulation axis (73) of the second pivoted lever (63) is placed inside the slot (67).
- 10 31. Pivoting window according to one of the claims 26 through 30, characterized by the fact that the casement (17) and window frame (15) feature circumferential sealing strips (65) which are attached in the closed position at two levels arranged at a distance from one another.
- 15 32. Pivoting window according to claim 31, characterized by the fact that the fitting (13) is altogether arranged within a gap between the circumferential sealing strips (65) in the closed position of the pivoting window (11).
- 20 33. Pivoting window according to one of the preceding claims, characterized by the fact that the fitting (13) is arranged on a profile (25), which forms an area of the window frame (15) on the side of the casement.
34. Pivoting window according to claim 33, characterized by the fact that the profile (25) is a profile made out of synthetic material.
- 25 35. Pivoting window according to claim 33 or 34, characterized by the fact that the guiding rail (31) is designed in the profile (25).
- 30 36. Pivoting window according to claim 35, characterized by the fact that the guiding rail (31) is exempted in an end area is supplemented by an end part (45), particularly with an arc segment (47).
- 35 37. Pivoting window according to one of the claims 26 through 36, characterized by the fact that the window frame (15) contains a frame made out of wooden slabs (23), for which crosscut piece of the profile (25) is fit on the outside on each wooden slab (23) forming the frame and that it overlaps the wooden slab (23) on the side of the casement.

WO 2006/042438

PCT/CH2005/000616

- 5 38. Pivoting window according to claim 37, characterized by the fact that the wooden slab (23) features at least a slot and that the profile (25) features at least a rib meshing with said slot.
- 10 39. Pivoting window according to one of the claims 26 through 38, characterized by the fact that the casement (17) features a frame (27) and a laterally protruding tier vitrification (19) across the frame.
40. Pivoting window according to one of the claims 26 through 39, characterized by a fitting (13) according to one of the claims 2 through 25.

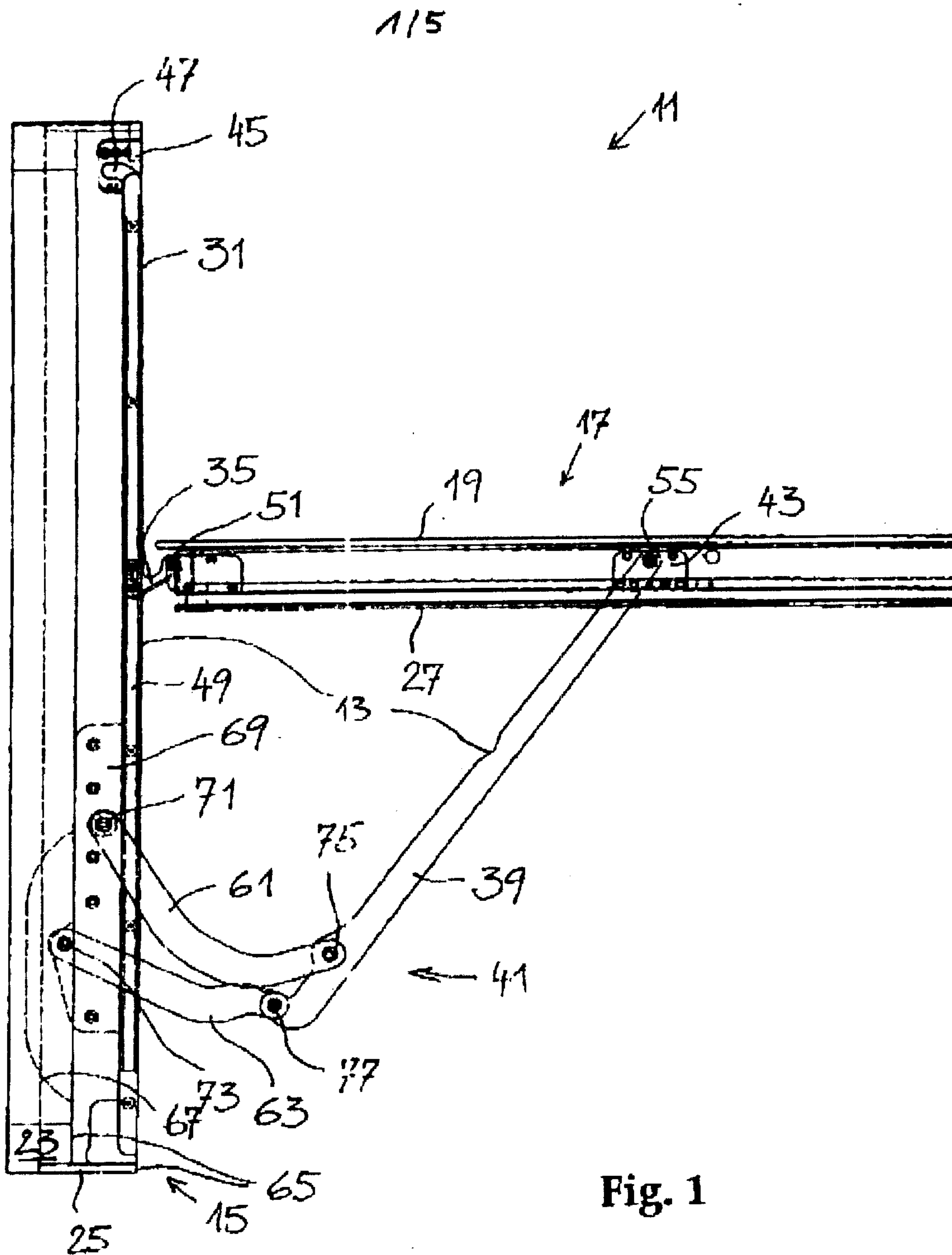

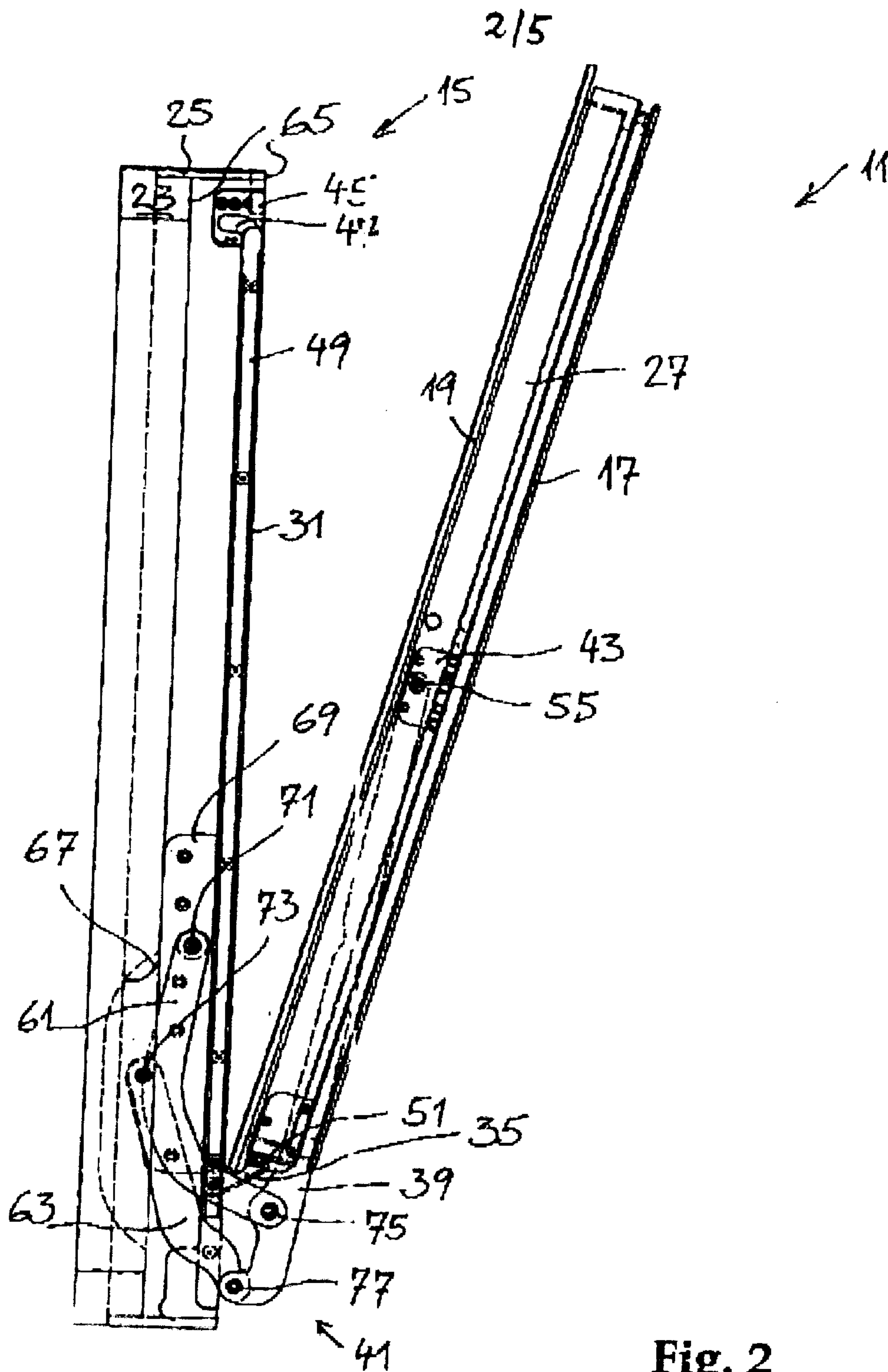

Fig. 2

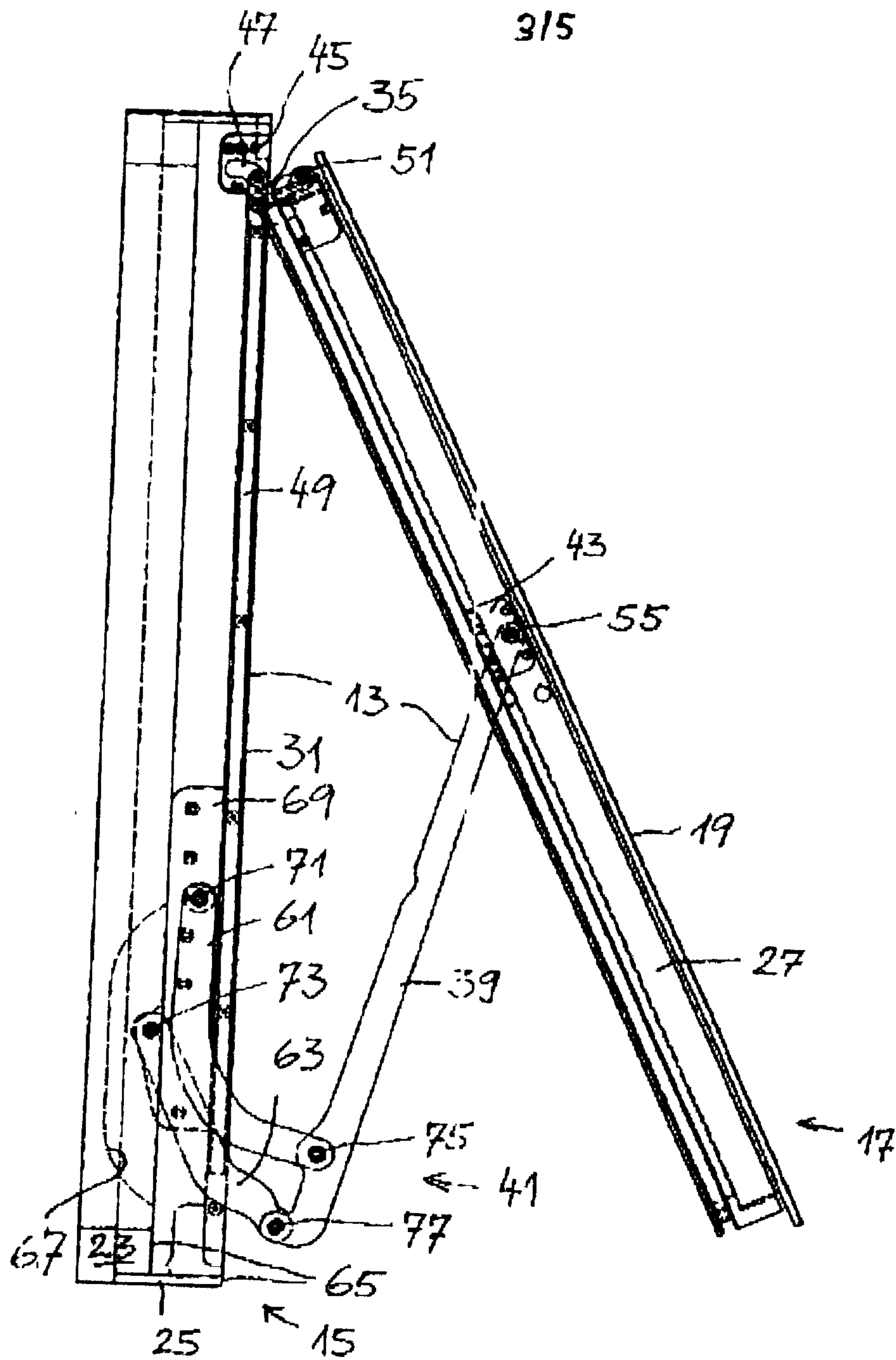

Fig. 3

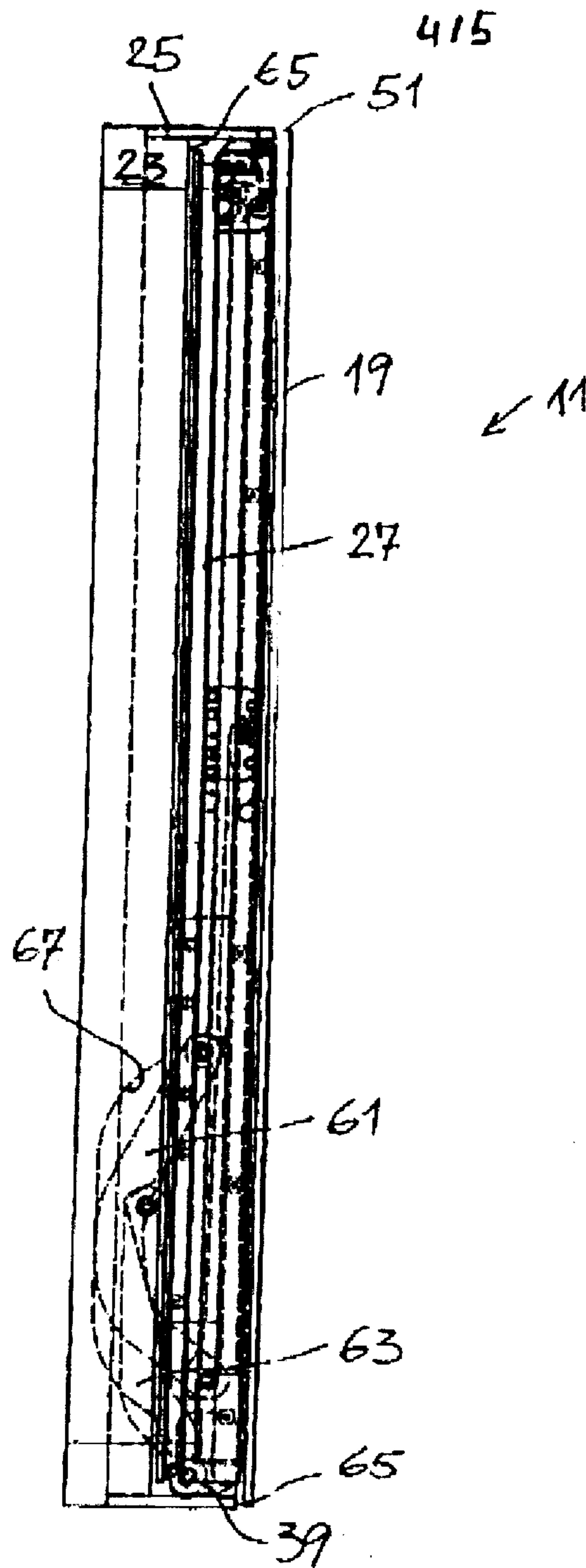

Fig. 4

5/5

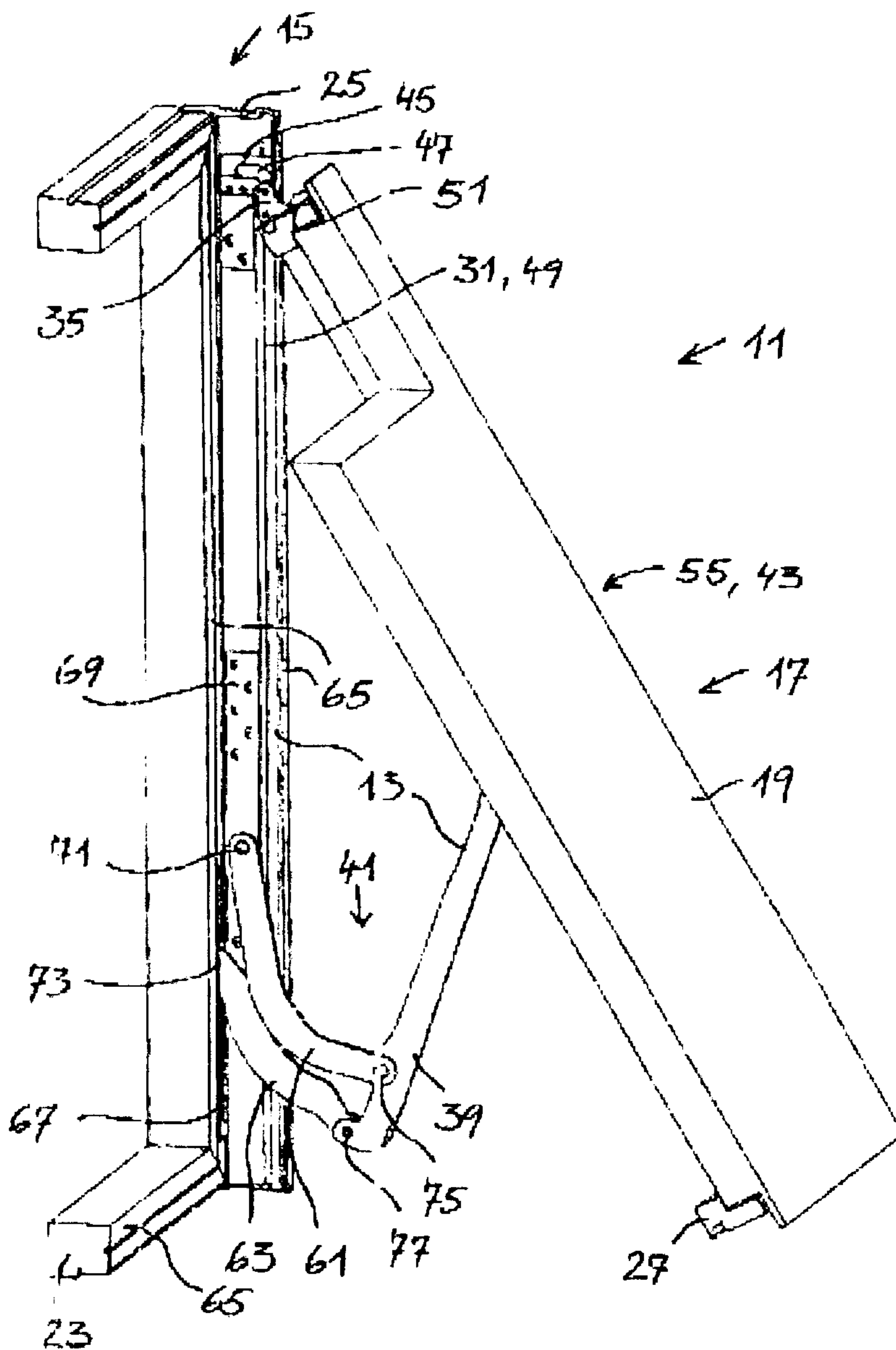

Fig. 5

