

(No Model.)

2 Sheets—Sheet 1.

J. H. FULTON.

STRAW CARRIER FOR THRASHING MACHINES.

No. 413,251.

Patented Oct. 22, 1889.

Fig. 1.

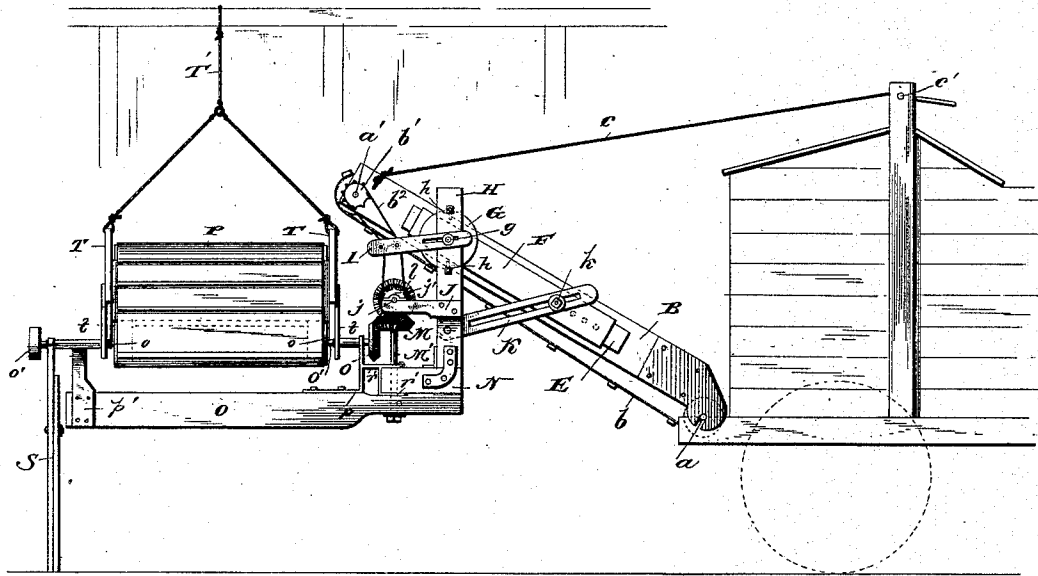
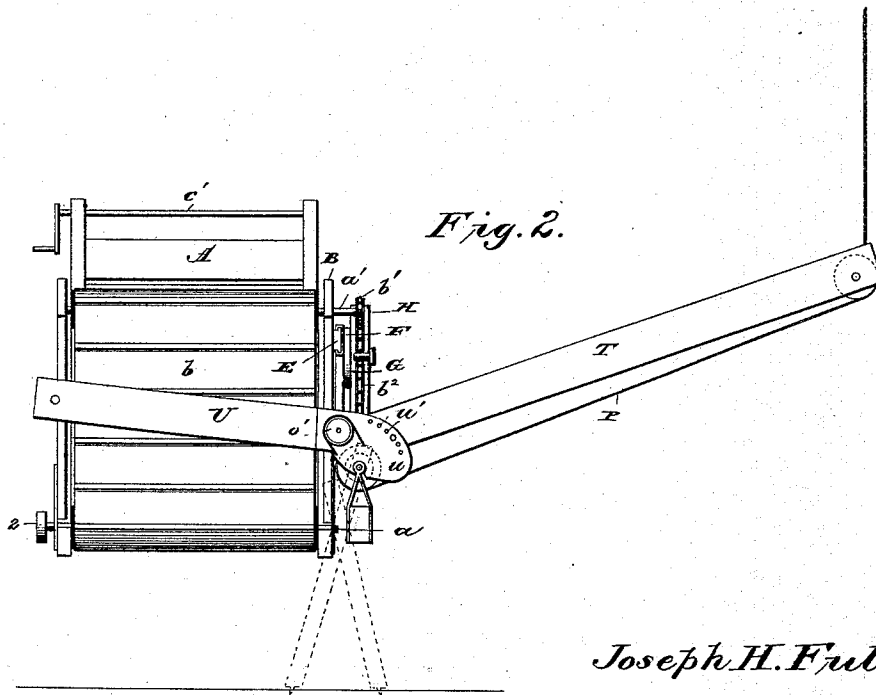

Fig. 2.



Joseph H. Fulton.

Inventor

Witnesses

G. S. Elyitt.
 W. Johnson

By his Attorneys

J. H. FULTON.

STRAW CARRIER FOR THRASHING MACHINES.

No. 413,251.

Patented Oct. 22, 1889.

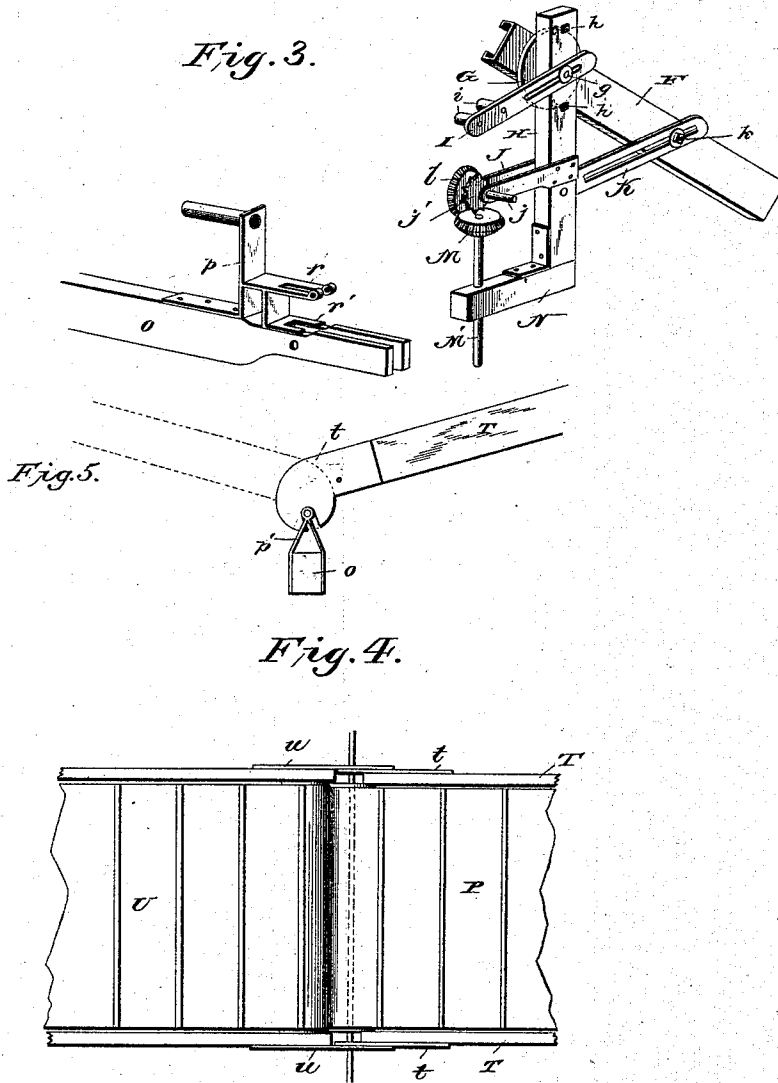

Joseph H. Fulton.

Witnesses

G. S. Elliott.
M. Johnson

Inventor

By his Attorneys

[Signature]

UNITED STATES PATENT OFFICE.

JOSEPH H. FULTON, OF WEST LEBANON, PENNSYLVANIA.

STRAW-CARRIER FOR THRASHING-MACHINES.

SPECIFICATION forming part of Letters Patent No. 413,251, dated October 22, 1889.

Application filed June 20, 1889. Serial No. 314,926. (No model.)

To all whom it may concern:

Be it known that I, JOSEPH H. FULTON, a citizen of the United States of America, residing at West Lebanon, in the county of Indiana and State of Pennsylvania, have invented certain new and useful Improvements in Straw-Carriers for Thrashing-Machines; and I do hereby declare the following to be a full, clear, and exact description of the invention, such as will enable others skilled in the art to which it appertains to make and use the same, reference being had to the accompanying drawings, and to letters or figures of reference marked thereon, which form a part of this specification.

My invention relates to certain new and useful improvements in straw-stackers.

The object of my invention is to provide a stacker adapted to be used in connection with a thrashing-machine for carrying the straw therefrom and depositing it upon elevators or carriers which are so connected to the elevator attached to the thrashing-machine that the carriers may be moved to convey the straw to different points, either to the right or left of the thrashing-machine, as will be hereinafter fully set forth, and particularly pointed out in the claims.

In the accompanying drawings, Figure 1 is a side view of a part of a thrashing-machine and elevator, showing my improved carrier and connections therefor attached to the elevator-frame to convey the straw to the left of the thrashing-machine. Fig. 2 is an elevation showing the carriers arranged to deposit the straw to the right of the thrashing-machine. Fig. 3 is a detail perspective view of the mechanism employed for connecting the carrier to the driving mechanism attached to the elevator. Fig. 4 is a detail plan view of the removable section employed at the end of the elevator-frame B when the straw is to be carried to the right, and Fig. 5 is a detail view showing the engaging end of one of the side pieces of the conveyer.

A refers to the thrashing-machine, to which the frame of the elevator B is pivoted. This frame can be adjusted to the proper vertical angle, as it is capable of swinging upon its pivot *a*, which are extensions of the bearings of the shaft over which the carrier-belt *b* passes.

The shaft *a* is provided with suitable pulleys, and the belt *b* passes over pulleys mounted on the shaft *a'* at the upper end of the elevator-frame, said shaft being provided at one end with a sprocket-wheel *b'*, over which passes a driving-chain. The elevator-frame B is adjustable at different angles, and is supported in an inclined position by the rope or flexible connection *c*, attached at one end to the elevator-frame, while the opposite end passes around a shaft *c'*, provided with a crank-handle for rotating said shaft to raise or lower the frame B. The shaft *a* extends beyond the sides of the thrashing-machine, and is journaled to the sill-pieces thereof, and upon one of the extended ends is secured a driving-pulley 2, over which is to be passed a belt driven from one of the rotary wheels of the thrashing-machine, which is in turn driven by the engine.

To one of the side pieces of the elevator-frame B is rigidly secured a plate E, extending parallel with the said side piece, and upon this plate is secured a sliding plate F, the edges of which are bent to overlap the upper and lower edges of the plate E. This sliding plate F, to which is attached a disk G, is held in place by means of a bolt *g*, which passes through the standard H, disk G, and sliding plate F, and enters a screw-threaded perforation in the plate E, and this disk and standard are held rigid by the clamps *h*, operated by nuts. The bolt *g* also serves to connect to the standard H a slotted arm I, provided with idle pulleys *i*, over which passes the sprocket-chain *b'*. The disk G and sliding plate F are rigidly connected to each other, and this sliding plate is provided near its lower end with an opening or perforation which registers with the perforations in the plate E, the said perforations being screw-threaded and engaged by a bolt *k*, passing through a slot in the arm K, pivoted to the standard H, as shown by dotted lines, Figs. 1 and 3. By means of this construction the standard H provides a rigid support for the upper end of the elevator B and permits adjustment of said frame thereon.

The bolt *g*, hereinbefore referred to, is similar in construction to the bolt *k*, and after passing through the slotted arm I, standard

H, disk G, and sliding plate F engages by means of screw-threads formed thereon with a screw-threaded perforation in the plate E. The arm I is employed as a belt-tightener, and by moving the same upon the bolt *g* the sprocket-chain *b*² can be suitably lengthened or shortened when the elevator B is raised or lowered or the sliding disk moved up or down.

10 The standard H is provided beneath the arm I with a projecting arm J, which is rigidly attached thereto and carries at its outer end journals for a shaft *j*, upon which is mounted a sprocket-wheel *j'* and beveled cog-wheel *l*, the cog-wheel meshing with the upper teeth of a double-beveled cog-wheel M, mounted on a vertical shaft M', and this shaft or bolt M' is firmly secured in the arm J and foot-piece N of the standard H, and, 20 projecting below the foot-piece and beam O, the end thereof is screw-threaded to receive a clamping-nut for securing the frame of the conveyer P in any desired position. The lower teeth of the cog-wheel M mesh with a cog-wheel, keyed upon the end of the shaft O', said shaft carrying pulleys *oo*, over which passes the conveying-belt P. On the outer end of shaft O' is placed pulley *o'*, on which is placed the driving-belt for the supplemental carrier U.

30 The lower frame of the conveyer P is provided with bearings *p* and *p'*, the bearing *p* having projections *r* and *r'* formed thereon, which are bifurcated to receive the shaft M'. The ends of the projections *r* are provided with perforations through which can be passed a pin for securing the slotted end thereof to the shaft M', and the lower member *r'* lies on each side of a slot formed in the end of the beam to which these castings are attached. The beam to which these castings or bearings for the shaft O' is attached can by this construction be swung or turned upon the foot-piece N of the standard H, so that the conveyer can be adjusted to any angle desired. The opposite end of the beam is supported by legs S, pivoted to each other, said legs having a suitable socket or hook for engaging with the end of the bearing *p'* to support the frame.

50 The side pieces T T of the conveyer P are provided at their ends with plates *t*, the ends of which are slotted to form hooks to engage with the bearings *p p'* and permit the frame and conveyer-belt to be adjusted at the proper angle, where it is held by means of flexible connections or rope T', which are connected to the frame and to some suitable support.

60 When it is desired to convey the straw to the right, as shown in Fig. 2, the side frames T T are unhooked from the shaft, and their position transversely across the end of the elevator-frame will be changed by simply changing the relative horizontal position of the frames T T, so as to reverse their slotted ends and engagement with the shaft, as shown in both dotted and full lines, Fig. 5. Of

course, with the frames T T changed as indicated in Fig. 2, there will necessarily have to be some intermediate means to convey the straw from the elevator-frame to the conveyer P, and to provide for this a section U is brought into requisition, its position being immediately under and transverse to the end of the elevator-frame. One end of said section U is supported by any suitable means engaging the end of the frame, while its other end is provided with segmental plates *u*, each provided with a series of perforations *u'*, through one of which passes a bolt to adjustably connect to and support the said end of the section U by the side frames T T. This supplemental frame U is provided with suitable pulleys and belts for conveying the straw, as it falls from the elevator B, to the conveyer P, to be deposited to one side of the machine.

75 When it is desired to form merely a continuation of the elevator B, the construction shown in Fig. 2 is used, the supplemental carrier U being dispensed with and the conveyer P swung in position to be on a line with the elevator B.

90 With this device I am enabled to employ a straight section or ordinary carrier at the point of delivery from the thrasher, which can be raised or lowered at its delivery end, said carrier being so geared that it will operate the conveyer P to deliver at different points either to the right or left of the thrasher and at any elevation it is possible to work a straw-carrier.

100 The device hereinbefore described can be set up or adjusted to work at either side of the elevator-frame. To change the device to work at the opposite side from that shown in Fig. 1, I firmly secure a second plate E to the opposite side of the elevator and place the sliding frame F upside down thereon, also reversing the clamps in the standard, bolts, slotted braces, and change the beveled cog-wheel to the opposite end of its shaft. I also place a sprocket-wheel on the end of the shaft *a*, these being all the changes needed when it is desired to convey straw to the opposite side of the thrasher, unless it is desired to lengthen the carrier or work the carrier P in connection with the supplemental frame U, hereinbefore described.

120 The section U, I consider an extra attachment to my improvement.

125 By employing the sliding device attached to the elevator-frame B, hereinbefore described, the standard H and legs S provide a rigid support for the conveyer P, and also allows said conveyer to be adjusted to meet the delivery of straw from the elevator B whenever it is desired to convey straw either to the right or left of a right angle at either side of the thrasher.

130 Having thus described my invention, what I claim as new, and desire to secure by Letters Patent, is—

1. The combination, in a straw-stacker

thrashing-machine, of the elevator-frame B, provided with an adjustable frame carried thereby, said frame having suitable driving-gear, with a second adjustable carrier-frame secured to the adjustable frame and driven by the gear thereof, substantially as shown.

2. In combination, in a straw-stacker thrashing-machine, the elevator-frame B, pivotally attached to the thrashing-machine, and said frame to be adjustable vertically, a plate attached to the side of the elevator-frame and adapted to support adjustably one end of a frame composed of a standard H, foot-piece N, and beam O, gearing supported by the standard H, and a second adjustable conveyer secured to the foot-piece N of the adjustable frame, substantially as and for the purpose set forth.

3. The combination, in a straw-stacker for thrashing-machines, of an elevator B, carrying a frame which is adjustable thereon, said frame carrying a horizontal shaft having a sprocket-wheel and beveled pinion mounted thereon, the sprocket-wheel being driven by a belt from the sprocket-wheel on the elevator-frame, and a gear-wheel M, having teeth on both faces thereof, its lower teeth meshing with the beveled wheel attached to the shaft of the conveyer-frame P by an adjustable frame, substantially as shown, and for the purpose set forth.

4. In combination, in a straw-stacker thrashing-machine, an elevator B, either one of the side frames thereof having a plate E attached thereto, a disk G, rigidly secured to a movable plate adjustable upon the plate E, a standard H, pivotally secured to the disk and provided with clamps h, a slotted arm K, serving as a brace for the standard H, belt-tightener, and guide I, and bearings for horizontal shafts, through which power is transmitted to a second conveyer pivotally attached to the foot-piece of the standard H, substantially as shown, and for the purpose set forth.

5. The combination, in a straw elevator or carrier for thrashing-machines, of an elevator B, provided with a conveying-belt, and an adjustable frame, as shown, secured to one side of the elevator-frame, a second carrier mounted between the side frames T T, said side frames being adapted to be pivotally secured upon the shaft O' so as to be reversed thereon and convey the straw from the first elevator either to the right or left of the thrashing-machine, and a supplemental conveyer U, substantially as shown, and for the purpose set forth.

In testimony whereof I affix my signature in presence of two witnesses.

JOSEPH H. FULTON.

Witnesses:

J. A. C. RUFFNER,
JOHN MCGAUGHEY.