

**(12) STANDARD PATENT**  
**(19) AUSTRALIAN PATENT OFFICE**

(11) Application No. **AU 2005209272 B2**

(54) Title  
**Suture loading**

(51) International Patent Classification(s)  
**A61B 17/04** (2006.01)                      **A61B 17/06** (2006.01)

(21) Application No: **2005209272**                      (22) Date of Filing: **2005.01.27**

(87) WIPO No: **WO05/072628**

(30) Priority Data

(31) Number	(32) Date	(33) Country
<b>10/765,214</b>	<b>2004.01.28</b>	<b>US</b>

(43) Publication Date: **2005.08.11**

(44) Accepted Journal Date: **2011.07.28**

(71) Applicant(s)  
**Smith & Nephew, Inc.**

(72) Inventor(s)  
**Bojarski, Ray;Sikora, George**

(74) Agent / Attorney  
**Davies Collison Cave, 1 Nicholson Street, Melbourne, VIC, 3000**

(56) Related Art  
**WO 01/35833**  
**US 5741277**

(12) INTERNATIONAL APPLICATION PUBLISHED UNDER THE PATENT COOPERATION TREATY (PCT)

(19) World Intellectual Property Organization  
International Bureau



(43) International Publication Date  
11 August 2005 (11.08.2005)

PCT

(10) International Publication Number  
WO 2005/072628 A1

- (51) International Patent Classification<sup>7</sup>: A61B 17/04, (74) Agent: DEVLIN, Peter, J.; Fish & Richardson P.C., 225 Franklin Street, Boston, MA 02110-2804 (US).  
17/06
- (21) International Application Number: PCT/US2005/002346
- (22) International Filing Date: 27 January 2005 (27.01.2005)
- (25) Filing Language: English
- (26) Publication Language: English
- (30) Priority Data: 10/765,214 28 January 2004 (28.01.2004) US
- (71) Applicant (for all designated States except US): SMITH & NEPHEW, INC. [US/US]; 1450 Brooks Road, Memphis, TN 38116 (US).
- (72) Inventors; and
- (75) Inventors/Applicants (for US only): BOJARSKI, Ray [US/US]; 32 Colleens Way, Attleboro, MA 02703 (US). SIKORA, George [US/US]; 1529 Plymouth Street, Bridgewater, MA 02324 (US).
- (81) Designated States (unless otherwise indicated, for every kind of national protection available): AE, AG, AL, AM, AT, AU, AZ, BA, BB, BG, BR, BW, BY, BZ, CA, CH, CN, CO, CR, CU, CZ, DE, DK, DM, DZ, EC, EE, EG, ES, FI, GB, GD, GE, GH, GM, HR, HU, ID, IL, IN, IS, JP, KE, KG, KP, KR, KZ, LC, LK, LR, LS, LT, LU, LV, MA, MD, MG, MK, MN, MW, MX, MY, MZ, NA, NI, NO, NZ, OM, PG, PH, PL, PT, RO, RU, SC, SD, SE, SG, SK, SL, SY, TJ, TM, TN, TR, TT, TZ, UA, UG, US, UZ, VC, VN, YU, ZA, ZM, ZW.
- (84) Designated States (unless otherwise indicated, for every kind of regional protection available): ARIPO (BW, GH, GM, KE, LS, MW, MZ, NA, SD, SL, SZ, TZ, UG, ZM, ZW), Eurasian (AM, AZ, BY, KG, KZ, MD, RU, TJ, TM), European (AT, BE, BG, CH, CY, CZ, DE, DK, EE, ES, FI, FR, GB, GR, HU, IE, IS, IT, LT, LU, MC, NL, PL, PT, RO, SE, SI, SK, TR), OAPI (BF, BJ, CF, CG, CI, CM, GA, GN, GQ, GW, ML, MR, NE, SN, TD, TG).

Published:  
— with international search report

[Continued on next page]

(54) Title: SATURE LOADING

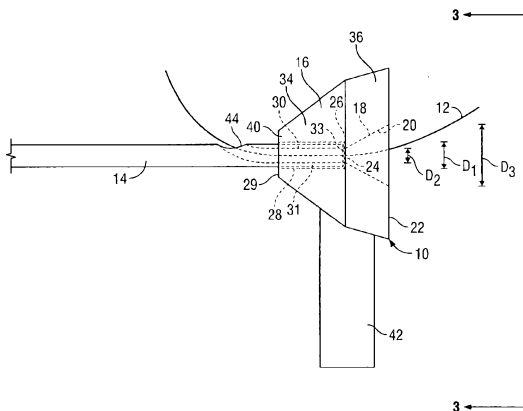

(57) Abstract: A device includes a body (16) defining a tapered hole (18) for guiding a member, such as a suture thread (12), into a tube (14), and a slot (32) communicating with the hole for separating the body and the member. The body defines a bore (28) for receiving the tube. The bore communicates with the tapered hole. The bore has a constant diameter or is tapered. A width of the bore is greater than a width of a narrowest portion of the tapered hole. The slot extends from the tapered hole and the bore to an external surface of the body. A method includes coupling a body to an end of a tube, guiding a member into the tube through a tapered hole, and separating the body and the member by passing the member through a slot.

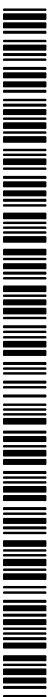

WO 2005/072628 A1



— *before the expiration of the time limit for amending the claims and to be republished in the event of receipt of amendments*

*For two-letter codes and other abbreviations, refer to the "Guidance Notes on Codes and Abbreviations" appearing at the beginning of each regular issue of the PCT Gazette.*

2005209272 08 Jul 2011

- 1 -

## *Suture Loading*

### **TECHNICAL FIELD**

This invention relates to suture loading and to the loading of other members into a tube. While the invention extends to the loading of other members, for convenience only  
5 it will be exemplified with reference to suture.

### **BACKGROUND**

Suture threads are used in various techniques for tissue repair. Various types of suture pushers are used to guide and insert suture threads into tissue, especially in arthroscopic surgery. When using a suture pusher, a suture thread is threaded through an  
10 opening or window in the suture pusher, much like threading a needle when sewing.

### **SUMMARY**

According to the invention, a loading device comprises:

guide means for guiding a member into a tube, the guide means including means for separating the guide means and the member; and

15 a tube having an end configured for communication with the guide means;

wherein the guide means comprises a body defining a tapered hole, and a bore for receiving the tube, wherein the bore is in communication with the tapered hole; and

the means for separating comprises a slot extending from the tapered hole and the bore to an external surface of the body.

20 Also according to the invention, a method for using the device described in the immediately preceding paragraph comprises:

coupling the body to said end of the tube;

guiding the member into the tube through the tapered hole in the body; and

separating the body and the member by passing the member through the slot.

25 Embodiments of the device may include one or more of the following features.

The bore has a constant diameter, is tapered, and/or has a width greater than a width of a narrowest portion of the tapered hole. The tube defines an opening for receiving the member, the opening having a width substantially the same as a width of a narrowest

2005209272 08 Jul 2011

- 2 -

portion of the tapered hole. The member comprises a suture thread. A handle extends from the guide means.

Advantages of the invention include, e.g., facilitating the threading of suture thread into an opening in a tube, and avoiding fraying of suture during insertion into the tube. Also, due to the ease of insertion, operating time during surgery can be reduced.

The details of one or more embodiments of the invention, given by way of example only, are set forth in the accompanying drawings and the description below.

### **DESCRIPTION OF DRAWINGS**

**Fig. 1** is a side view of a suture loader being used to insert a suture thread into a tube.

**Fig. 2** is a perspective view of the suture loader of Fig. 1.

**Fig. 3** is a front view of the suture loader of Fig. 1, taken along lines 3-3 in Fig. 1.

**Fig. 4** is a side view of the suture loader of Fig. 1 showing the suture thread and the suture loader being separated.

**Fig. 5** is a front view of a second embodiment of a suture loader.

**Fig. 6** is a side view of a third embodiment of a suture loader.

**Fig. 7** is a perspective view of the suture loader of Fig. 6.

**Fig. 8** is a side view of a fourth embodiment of a suture loader.

**Fig. 9** is a side view of a fifth embodiment of a suture loader.

**Fig. 10** is a side view of a sixth embodiment of a suture loader.

**Fig. 11** is a side view of a seventh embodiment of a suture loader.

### **DETAILED DESCRIPTION**

Referring to Fig. 1, a suture loader 10 for use in threading a member, e.g., a suture thread 12, into a tube 14 includes a body 16 defining a tapered hole 18. Hole 18 tapers from a larger diameter opening 20 at a top surface 22 of suture loader 10, to a smaller diameter opening 24 at an internal region 26 of suture loader 10. Larger diameter opening

2005209272 08 Jul 2011

- 3 -

20 facilitates the threading of suture thread 12 into tapered hole 18. Suture loader 10 further defines a bore 28 extending from a bottom surface 29 of suture loader 10 to internal region 26 for communication with hole 18. Bore 28 is sized to receive tube 14 such that an opening 30 in an end portion 31 of tube 14 is aligned with smaller diameter opening 24 of hole 18 to receive suture thread 12 from hole 18. Bore 28 has a substantially constant diameter or tapers from a wider portion at bottom surface 29 to a narrower portion at internal region 26, for reasons discussed below.

Referring to Fig. 2, body 14 also defines a slot 32 communicating with tapered hole 18 and bore 28. Slot 32 extends from tapered hole 18 and bore 28 to an external surface 34 of suture loader 14 and to top and bottom surfaces 22, 29. Slot 32 allows the user to separate body 16 and suture thread 12, after suture thread 12 has been threaded through tapered hole 18 and into opening 30 in tube 14, by passing suture thread 12 through slot 32 and out of body 16.

Referring again to Fig. 1, to receive tube 14 in bore 28, a diameter  $D_1$  of bore 28 is slightly greater than an outer diameter of tube 14. To facilitate inserting suture thread 12 through opening 30 in tube 14, a diameter  $D_2$  of opening 24 is approximately the same as or slightly greater than a diameter of an entry hole 33 of opening 30 in tube 14. Thus, diameter  $D_1$  of bore 28 is greater than diameter  $D_2$  of opening 24. As previously discussed, diameter  $D_3$  of opening 20 is larger than diameter  $D_2$  of opening 24. For example, for a tube 14 having an outer diameter of approximately 0.0625 inches, and a diameter of entry hole 33 of 0.023 to 0.025 inches, diameter  $D_1$  of bore 28 is approximately 0.063 to 0.065 inches, diameter  $D_2$  is approximately 0.027 to 0.030 inches, and diameter  $D_3$  is approximately 0.120 to 0.130 inches. Alternatively, bore 28 can taper to a smaller diameter at internal region 26 that is smaller than the diameter of tube 14, e.g., by about 0.003 inches, such that there is a slight friction fit between tube 14 and bore 28, which helps to keep suture loader 10 on tube 14 during threading of suture thread 12, and which allows suture loader 10 to be subsequently removed from tube 14.

Referring to Fig. 3, slot 32 has a width  $W_1$  slightly smaller than diameter  $D_2$  of opening 24, but slightly larger than a width of suture thread 12. Width  $W_1$  is selected such

2005209272 08 Jul 2011

- 4 -

that the user can thread suture thread 12 through tapered hole 18 without suture thread 12 unintentionally slipping out of slot 32 and can remove suture thread 12 through slot 32 once suture thread 12 has been inserted into opening 30 in tube 14. For example, for a diameter  $D_2$  of 0.027 to 0.030 inches and a suture thread width of 0.011 to 0.013 inches (size 0 suture thread), width  $W_1$  can be approximately 0.012 to 0.020 inches.

Referring again to Figs. 1 and 2, extending from body 14 is a substantially cylindrical handle 42 that allows the user to hold suture loader 10 in one hand while inserting suture thread 12 into suture loader 10 with the other hand. Handle 42 is oriented opposite of slot 32 to provide the user a visual and tactile reference as to the orientation of slot 32. External surface 34 of suture loader 10 includes a portion 36 that tapers from a larger width at top surface 20 to an intermediate width at internal region 26, and a bottom portion 40 that tapers from the intermediate width to a smaller width at bottom surface 29.

Suture receiving opening 30 in tube 14 extends from end portion 31 of tube 14 to a side port 44. An example of tube 14 in the form of a suture pusher is described in co-pending U.S. Patent Application No. US20040162569.

Referring to Figs. 1 and 4, in use, suture loader 10 is coupled to end portion 31 of tube 14 by inserting end portion 31 into bore 28, so that end portion 31 abuts internal region 26 around opening 24 and opening 30 is aligned with opening 24. Suture thread 12 is inserted into tapered hole 18 through opening 20 and guided through tapered hole 18 and into entry hole 33 of tube 14. Suture thread 12 is advanced through opening 30 and out port 44. Next, tube 14 is removed from bore 28 and suture thread 12 is separated from body 16 by passing suture thread 12 through slot 32, as shown in Fig. 4.

Referring to Fig. 5, an alternative suture loader 510 has a slot 532 for separating suture thread 12 and suture loader 510. Suture loader 510 includes a tapered portion 550 that serves to decrease the weight of suture loader 510 and facilitates molding of slot 532.

Referring to Figs. 6 and 7, a suture loader 610 includes a body 616 having a bottom portion 640, analogous to bottom portion 40, an intermediate portion 636, analogous to portion 36, an extended portion 670, and a slot analogous to the slot 32. Body 616 defines a tapered hole 618 that is longer than tapered hole 18 of suture loader

2005209272 08 Jul 2011

- 5 -

10 to more easily facilitate threading the suture thread into tapered hole 618. Extended portion 670 includes concave cutouts 676 (only one of which is shown) that lighten the weight of suture loader 610 and facilitate grasping body 616. Extending from body 614 is a handle 642 having two recessed sides 660 with ribs 662 that facilitate gripping by the user.

Figs. 8-11 show suture loaders 810, 910, 1010, and 1110 having varying shapes and contours of the tapered hole and body. Referring to Fig. 8, a hole 818 includes a constant diameter portion 821 leading to a tapered portion 825. Referring to Fig. 9, a tapered hole 918 curves from an opening 920 in a side surface 934 of suture loader 910 to a smaller diameter opening 924 such that opening 920 is substantially perpendicular to opening 924. Referring to Fig. 10, a tapered hole 1018 is formed by a straight walled portion 1021 and a tapered wall portion 1019. Referring to Fig. 11, an extended portion 1170 of a body 1116 is tapered from a wider diameter at an intermediate portion 1136 to a narrower diameter at a top surface 1120, in order to make suture loader 1110 lighter in weight. Each of the suture loaders 810, 910, 1010 and 1110 includes a slot analogous to the slot 32.

A number of embodiments have been described. Nevertheless, it will be understood that various modifications may be made. For example, the tapered hole can have any suitable shape that facilitates passing a suture into a tube, such as a hole having a square, triangular or other cross section. The slot can be any passage that extends from the tapered hole to the external surface and that allows the suture loader and the suture thread to be separated. Also, the dimensions of the tapered hole, bore, and slot can be varied to accommodate different size suture threads or different size tubes. The body can be made without a handle. The external surface of the body also can have any appropriate shape, such as box-shaped, semi-spherical, or dome-shaped. Also the body can have interstices or cut outs to reduce weight. The suture loader can be made of any suitable material such as stainless steel, plastic, or ceramic. The tube can have any suitable configuration such as being curved, straight, or bent, and being round, elliptical, square, or triangular in cross section. The opening in the tube can, for example, extend the entire length of the tube, through a portion of the tube and may terminate inside the tube or in



2005209272 08 Jul 2011

- 6 -

any of the walls of the tube. While embodiments have been disclosed for loading a suture thread onto a surgical instrument, it will be appreciated that the disclosed embodiments can be used to load any kind of filament onto an instrument that requires the filament to be passed through a narrow passage. These and other embodiments are within the scope  
5 of the following claims.

Throughout this specification and the claims which follow, unless the context requires otherwise, the word "comprise", and variations such as "comprises" and "comprising", will be understood to imply the inclusion of a stated integer or step or group of integers or steps but not the exclusion of any other integer or step or group of  
10 integers or steps.

The reference in this specification to any prior publication (or information derived from it), or to any matter which is known, is not, and should not be taken as an acknowledgment or admission or any form of suggestion that that prior publication (or information derived from it) or known matter forms part of the common general  
15 knowledge in the field of endeavour to which this specification relates.

2005209272 08 Jul 2011

- 7 -

## CLAIMS:

1. A device comprising:  
guide means for guiding a member into a tube, the guide means including means for separating the guide means and the member; and  
a tube having an end configured for communication with the guide means;  
wherein the guide means comprises a body defining a tapered hole, and a bore for receiving the tube, wherein the bore is in communication with the tapered hole; and  
the means for separating comprises a slot extending from the tapered hole and the bore to an external surface of the body.
  2. The device of claim 1, wherein the bore has a constant diameter.
  3. The device of claim 1, wherein the bore is tapered.
  4. The device of any one of the preceding claims, wherein a width of the bore is greater than a width of a narrowest portion of the tapered hole.
  5. The device of any one of the preceding claims, wherein an opening in the tube for receiving the member has a width which is substantially the same as a width of a narrowest portion of the tapered hole.
  6. The device of any one of the preceding claims, wherein the member comprises a suture thread.
  7. The device of any one of the preceding claims, further comprising a handle extending from the guide means.
- 
8. A device substantially as herein described with reference to the accompanying drawings.

2005209272 08 Jul 2011

- 8 -

9. A method for using a device according to any one of the preceding claims, the method comprising:

coupling the body to said end of the tube;

guiding the member into the tube through the tapered hole in the body; and

separating the body and the member by passing the member through the slot.

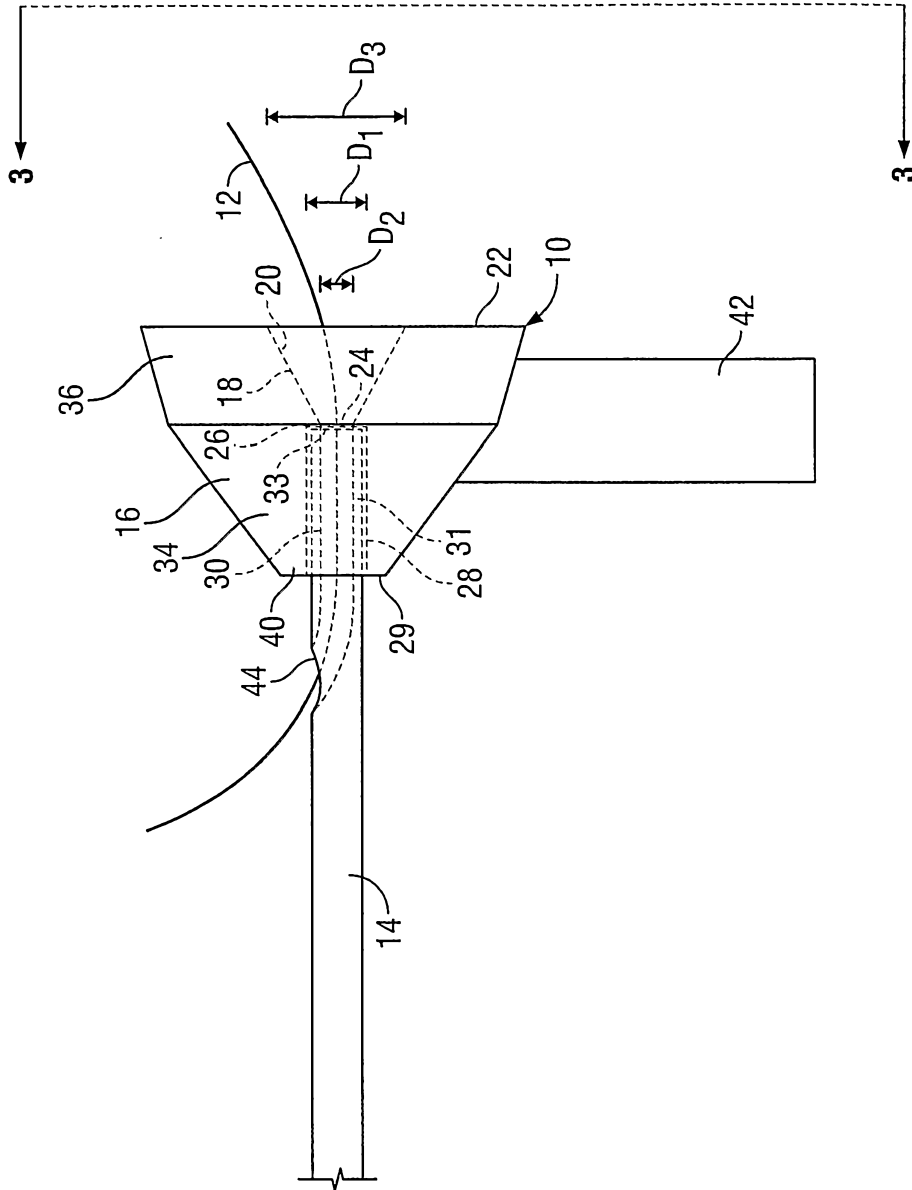

FIG. 1

2/6

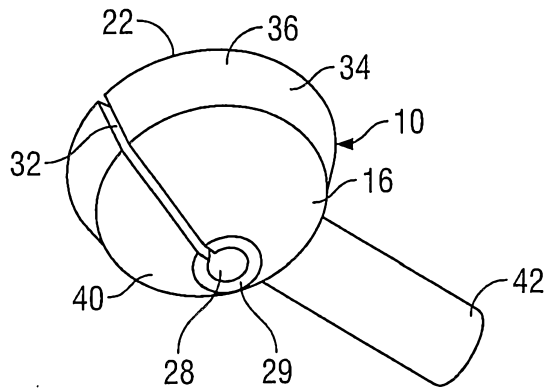

FIG. 2

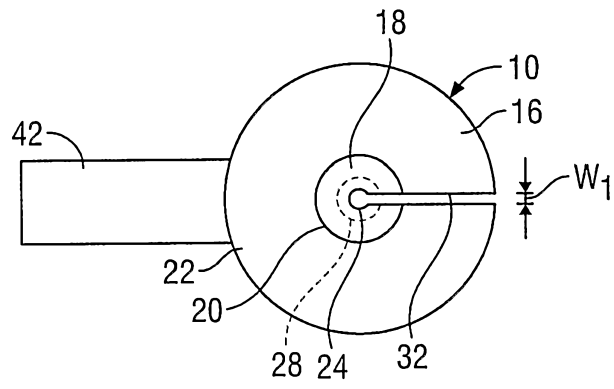

FIG. 3

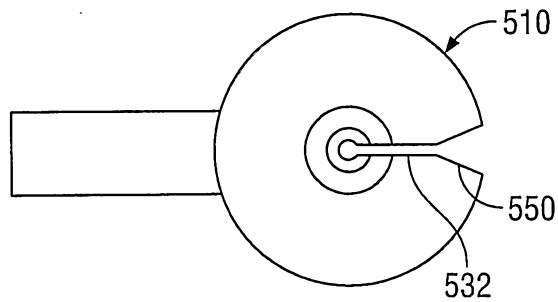

FIG. 5

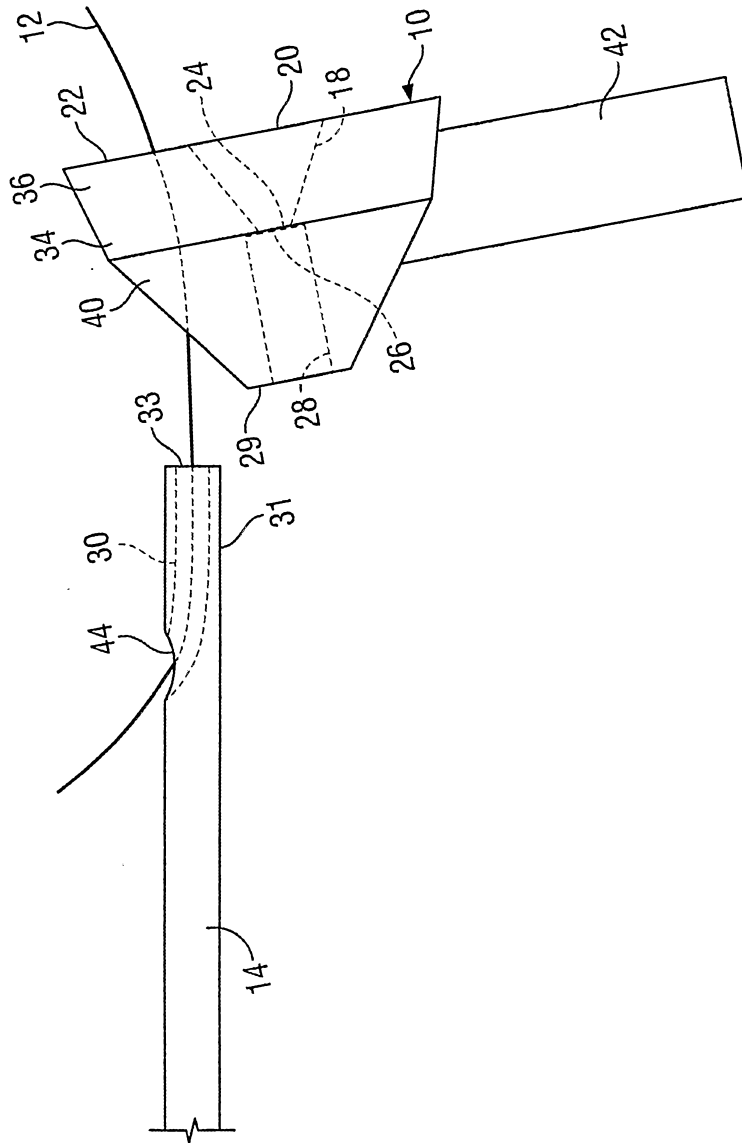

FIG. 4

4/6

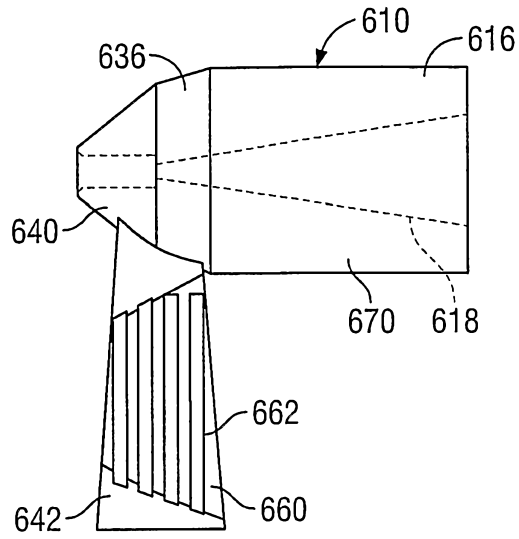

FIG. 6

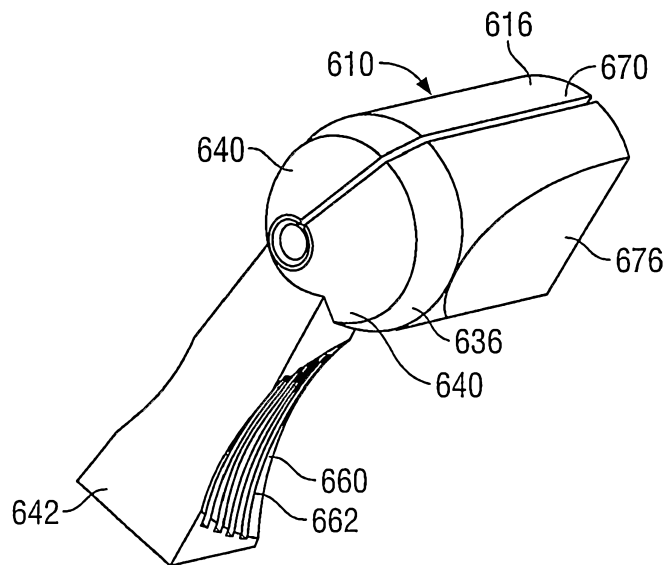

FIG. 7

5/6

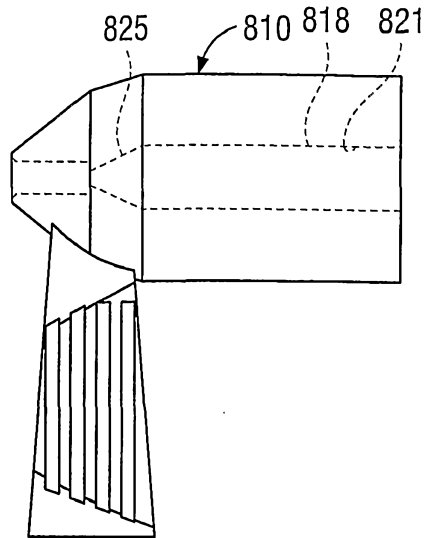

FIG. 8

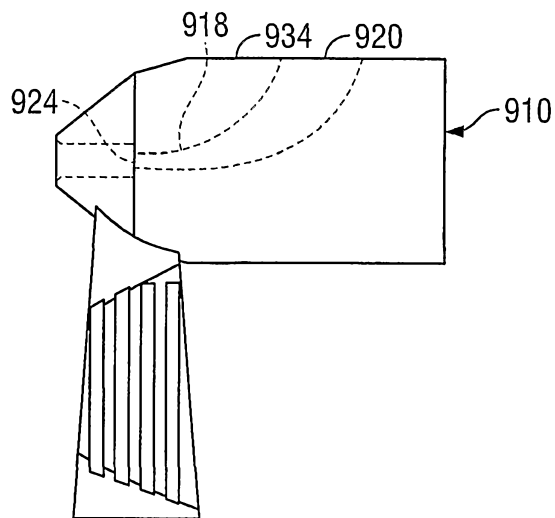

FIG. 9



6/6

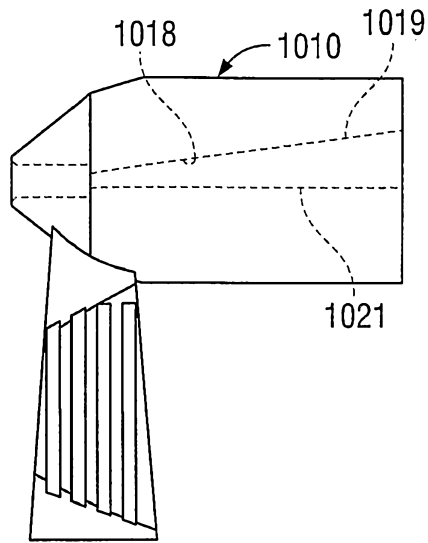

FIG. 10

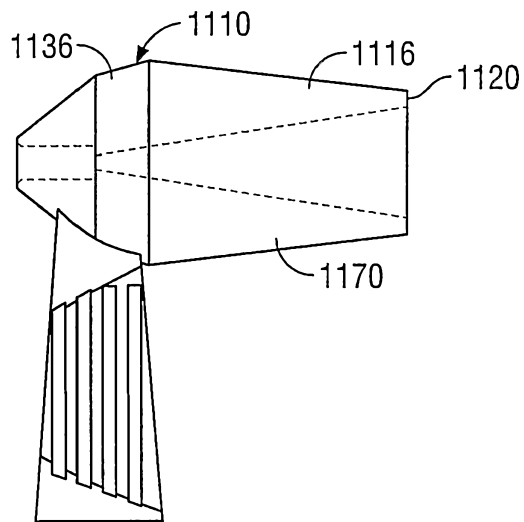

FIG. 11