

Feb. 17, 1953

M. D. BUIVID
ANTIFLAPPING LOCK

2,628,686

Filed Aug. 18, 1951

2 SHEETS—SHEET 1

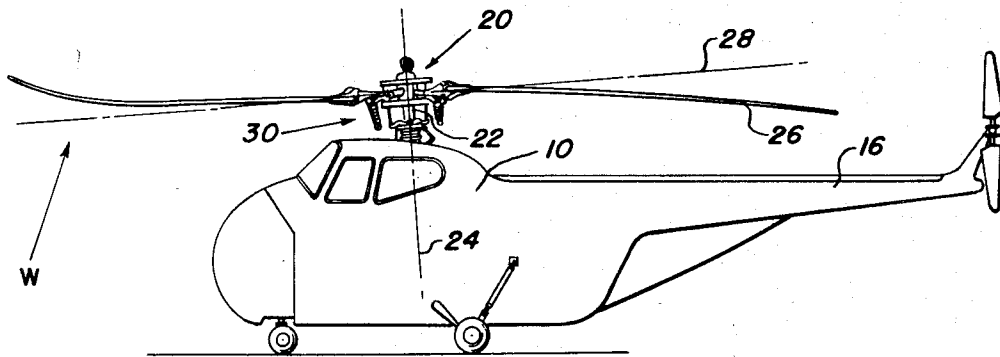

Fig. 1

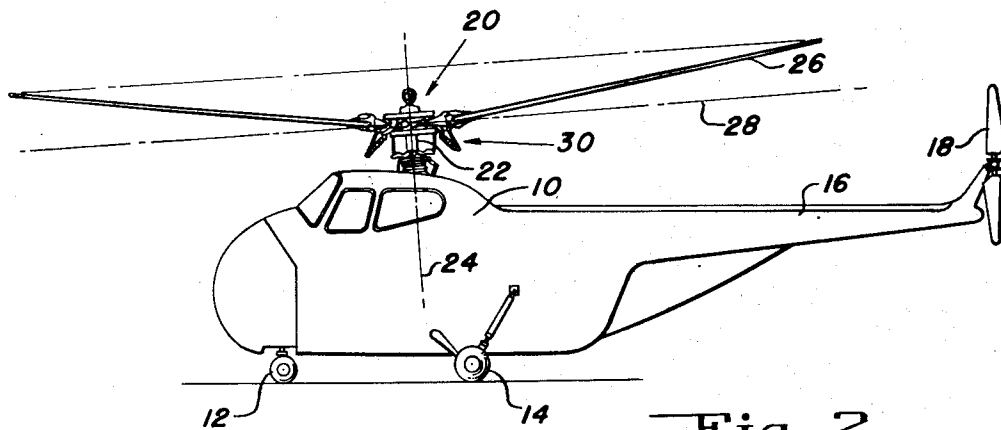

Fig. 2

INVENTOR
MICHEL D. BUIVID
BY *M. B. Tarkenton*
ATTORNEY

Feb. 17, 1953

M. D. BUIVID
ANTIFLAPPING LOCK

2,628,686

Filed Aug. 18, 1951

2 SHEETS—SHEET 2

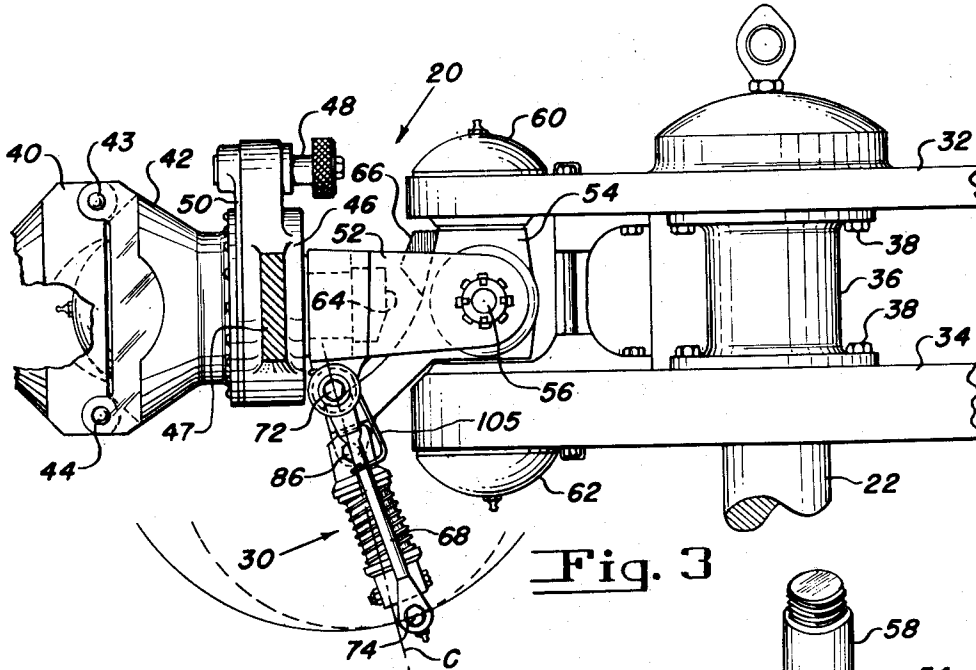

Fig. 3

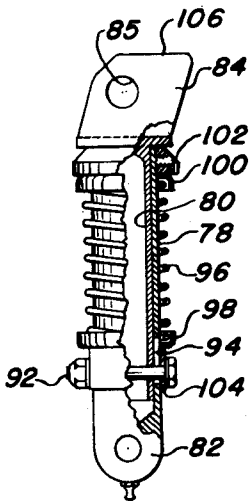

Fig. 5

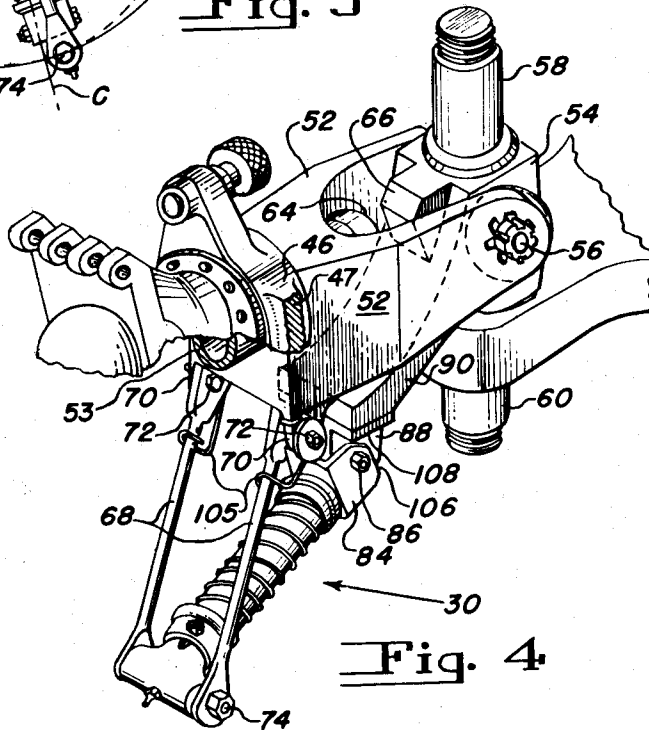

Fig. 4

INVENTOR
MICHEL D. BUIVID
BY *M. B. Tasker*
ATTORNEY

UNITED STATES PATENT OFFICE

2,628,686

ANTI-FLAPPING LOCK

Michel D. Buivid, Milford, Conn., assignor to
United Aircraft Corporation, East Hartford,
Conn., a corporation of Delaware

Application August 18, 1951, Serial No. 242,559

9 Claims. (Cl. 170-160.55)

1

This invention relates to helicopters of the type which are equipped with flapping rotor blades.

When a helicopter of this type is on the ground and its rotor blades are stationary or are rotating only slowly, the blades are susceptible to damage by a gust of wind which may flap a blade upwardly and allow it to drop violently. This may damage the blade or its mounting or it may deflect a rotating blade downwardly sufficiently to strike the fuselage of the ship and damage both the blade and the ship. Under these conditions, when the centrifugal forces acting on the blades are zero or are low, it is desirable to restrain the blades from flapping upwardly due to gusts. When, however, the blades are rotating above a predetermined safe R. P. M. at which the centrifugal forces acting on the blades straighten them and also prevent gusts from deflecting them dangerously out of their normal path of rotation, it is safe to release the lock on the blades and permit them to flap as they are intended to do in normal flight.

It is an object of this invention to provide improved means for restraining the rotor blades of a helicopter from flapping when the blades are not rotating or are rotating slowly while automatically releasing the same for flapping movement under flight conditions.

A further object of the invention is to provide a flapping lock for a helicopter blade which moves bodily with the blade as the latter moves about its drag hinge.

A further object of the invention is to provide an improved flapping restraining mechanism for helicopter rotor blades which automatically releases the blades at a predetermined rotor R. P. M. and which is extremely simple in construction and reliable in operation.

These and other objects and advantages of the invention will be pointed out in connection with the following detailed description of a preferred embodiment of the invention shown in the accompanying drawings.

In these drawings:

Fig. 1 shows a helicopter equipped with the flapping lock of this invention as the latter appears when on the ground with its rotor stationary and subjected to a wind gust.

Fig. 2 shows the helicopter of Fig. 1 with the blades unlocked and free to flap, the blades being shown in the upwardly coned position which they occupy when the blades are being rotated rapidly but at a low pitch setting.

Fig. 3 is an enlarged view of the rotor head illustrating the blade locking mechanism in the

2

locked position of Fig. 1, parts being broken away to facilitate illustration.

Fig. 4 is a still further enlarged view in perspective showing the blade lock in the unlocked position of Fig. 2 in which the blade is free to flap upwardly.

Fig. 5 is an enlarged detailed view partially in section of one of the locking members.

As shown in Figs. 1 and 2 the helicopter includes a fuselage 10 which is supported on the ground on nose wheels 12 and rear wheels 14. The fuselage includes a tail cone 16 at the outboard extremity of which a tail rotor 18 is supported for rotation about a generally horizontal axis. The main rotor generally indicated at 20 is rotatable about a rotor drive shaft 22, the axis of rotation 24 of which is slightly upwardly and forwardly inclined. The rotor blades 26 are pivotally connected to the rotor head so that in normal flight when the R. P. M. of the rotor is high, these blades will come upwardly as shown in Fig. 2 above the reference line 28 which is perpendicular to the rotor axis 24.

When the helicopter is on the ground and the rotor is either not rotating or is rotating slowly the blades 26 are subject to damage from gusts of wind which may whip the blades upwardly and allow them to drop suddenly with destructive force. In accordance with the present invention flap restraining locking means generally indicated at 30 is provided for each blade of the rotor which automatically operates in response to changes in R. P. M. of the rotor to permit the blades to flap upwardly in flight when the speed of the rotor is sufficient to generate blade protecting centrifugal forces but which locks the blades against upward flapping when they are stationary or rotating too slowly to produce these protective forces. Since the locking mechanisms associated with the several blades are identical, only one will be described.

The rotor head is mounted on the upper end of rotor drive shaft 22 and as shown in Fig. 3 includes parallel upper and lower plates 32 and 34 which are spaced apart on shaft 22 by a hub 36. The hub 36 has upper and lower flanges, and bolts 38 extend through these flanges and pass through the plates 32 and 34 to secure the latter in fixed parallel relation on shaft 22 and at right angles thereto.

The blades are pivotally supported at their inboard ends in spaced relation about the periphery of plates 32 and 34, the attaching means for one blade being shown in Fig. 3. The inboard end of each blade spar carries a fitting 40 which is se-

3

cured to a like fitting 42 by two pivot pins 43 and 44, a construction frequently used to permit folding of the blades by removing pin 43 and folding the blade on pin 44. During this folding movement the member 42 is permitted to rotate relative to a collar 46 which is part of the blade pitch control horn 47 (only a portion of which is shown) upon withdrawal of a pin 48 from the flange 50 on member 42. This blade folding mechanism is more fully shown and described in Patent No. 2,405,777, issued to me on August 13, 1946.

To provide blade pitch change the member 46, which carries blade pitch horn 47, is rotatably mounted on spindle 53 on the end of the flapping link, or hinge, 52 which is bifurcated at its in-board end to receive block 54 comprising the central portion of the drag hinge. A horizontal pin 56 extends through the bifurcated ends of flapping link 52 and through the block 54 and constitutes the flapping pivot for the blade. The block 54 of the drag hinge has integral upper and lower trunnion-like members 58 and 60 which are journaled in bearings (not shown) in plates 32 and 34 respectively, caps 60 and 62 being provided to enclose these bearings.

Upward flapping movements of the blade are limited by the engagement of surfaces 64 and 66 (Fig. 3) on flapping link 52 and block 54 respectively. Somewhat similar stop means are provided to prevent movement of the flapping link 52 beyond a certain distance below the horizontal position of this link shown in Fig. 3. These stop means are shown in my copending application Serial No. 208,911, filed February 1, 1951. As these stops form no part of the present invention they have been omitted from the drawings in the interest of clarity.

The flap restraining means 30 of the invention consists essentially of two linkages comprising a toggle, one of these linkages is shown in detail in Fig. 5 and the other includes a pair of parallel links 68 each of which is pivotally connected by a bolt 72 to one of a pair of spaced ears 70 depending from the flapping link 52. The lower ends of links 68 are connected by a through bolt 74 to the other toggle linkage, the bolt 74 comprising the common pivotal connection of the toggle assembly.

Referring to Fig. 5, it will be noted that this toggle linkage includes outer and inner telescoping cylindrical members 78 and 80. The outer cylindrical member 78 carries an apertured lug 82 through which bolt 74 extends while the inner cylinder carries a bifurcated lug 84 having apertures 85 through which the bolt 86 extends, this latter bolt also extending through depending ear 88 carried by a downwardly and outwardly extending bracket 90 which is formed integral with the drag link block 54. It will thus be evident that the two bolts 72 comprise the pivotal support for one end of the toggle mechanism and the bolt 86 comprises the pivotal support for the other end thereof, while bolt 74 comprises the common pivotal connection for the toggle linkages.

The outer and inner tubes 78 and 80 are permitted a small amount of axial movement by reason of the limited movement of a through bolt 92 carried by cylinder 80 in diametrically opposed longitudinal slots 94 in cylinder 78. This slot and bolt arrangement also prevents possible torsional displacement between these parts. The tubes 78 and 80 are constantly biased into the contracted position thereof shown in Fig. 5 in

4

which the end of tube 78 engages lug 84 by a compression spring 96, the opposite ends of which rest in cup-shaped washers 98 and 100. Cup 100 is supported by a nut 102 threaded onto the end of cylinder 78 while cup 98 is supported by a collar 104 which loosely surrounds tube 78 and is connected to the inner tube 80 by bolt 92. The spring 96 is sufficiently compressed between its end abutments to continuously urge the telescoping tubes 78 and 80 into their contracted positions as limited by the engagement of the free end of tube 78 and nut 102 with lug 84.

The locking toggle 30 is constantly biased by torsion springs 105 into the slightly over-center position shown in Fig. 3. As best shown in Fig. 4 these springs, which extend back of bolts 72, have their longer ends hooked over links 68 and their shorter ends hooked over ears 70 so as to bias links 68 about bolts 72 in a counterclockwise direction.

In the over-center position of the toggle shown in Fig. 3, the pivot bolt 74 has passed slightly to the right of a straight line C intersecting the pivot bolts 72 and 86 for the opposite ends of the toggle. The toggle is arrested in this slightly over-center position by the engagement of abutment surfaces 106 on the ends of the parallel ears of lug 84 with the abutment surfaces 108 of bracket 88 as shown in Fig. 3.

When the helicopter is on the ground and the rotor is either stationary or is turning slowly the locking toggle mechanism 30 occupies the over-center position shown in Figs. 1 and 3 in which the toggle locks the flapping link 52 and hence the blade against upward flapping movement due to a gust of wind W indicated in Fig. 1. Any tendency for the blade to move upwardly is absorbed in the toggle by thrust forces acting against the substantially in-line pivots 72, 74 and 86. The toggle in the Fig. 3 position effectively resists this thrust because the end of tube 78 carrying nut 102 engages lug 84, the toggle thus becoming a compact and rigid strut to resist upward forces directed against the blade. The relatively light force tending to rotate the toggle about the bolt 86 due to the over-center position of bolt 74 is resisted by the flat abutment surfaces 106 and 108 previously described.

When the speed of the rotor is increased to a predetermined R. P. M. at which the centrifugal forces acting on the blades are sufficient to safeguard the blades against flapping due to gusts of wind or the like, the centrifugal forces acting on the toggle mechanism 30 overcome the bias of springs 105 and the toggle moves into the broken position shown in Figs. 2 and 4, in which the blade is free to flap upwardly due to aerodynamic forces acting thereon.

It will be noted that in moving from the over-center locked position of Fig. 3 to the broken unlocked position of Fig. 4 the centrifugal forces have only to overcome the bias of springs 105 as the bolt 92 moves upwardly in slot 94. This slight telescoping movement of the tubes 78 and 80 is required due to the fact that the distance from bolt 74 to bolt 86 is somewhat less than the distance from bolt 74 to bolts 72. This telescoping movement afforded during the movement of bolt 92 in slot 94 thus enables the toggle to move from a blade locking position to a blade unlocking position even though the blade continues to rotate in a horizontal position as it may do if no blade pitch is imposing on the blade. The above described movement of the locking toggle from blade locking position to blade unlocking position

5

occurs at a much lower R. P. M. than that required for flight so that as the helicopter rotor is speeded up and the blade pitch is increased the blades will always be unlocked and free to come upwardly as the helicopter takes off.

Similarly when the helicopter comes in for a landing, as the blades slow down with the helicopter resting on the ground, the springs 105 will snap the locking toggles into the Fig. 3 position at the critical R. P. M. below which the centrifugal forces acting on the blades due to their rotation is not enough to protect the blades against being blown upward by a gust of wind.

While I have shown and described a preferred embodiment of the invention, it will be understood that various changes may be effected in the construction and arrangement of the parts without departing from the scope of the invention.

I claim:

1. In a helicopter rotor, a hub, a drag hinge 20 pivoted to said hub having a depending projection, a blade having a root portion pivoted to said drag hinge for flapping movements, said root portion having a depending portion terminating adjacent said projection, and centrifugally operated locking means including a toggle having a 25 pivotal connection at its opposite extremities with said blade and with said projection and movable bodily with said blade as the latter moves about said drag hinge for effecting a locking connection 30 between said projection and said depending portion and preventing upward flapping of said blade when the latter is rotating below a predetermined R. P. M.

2. In a helicopter rotor, a hub, a drag hinge 35 pivoted to said hub having a depending projection, a blade having a root portion pivoted to said drag hinge for flapping movements, said root portion having a depending portion terminating adjacent said projection, centrifugally 40 operated locking means including a toggle having a pivotal connection at one end with said blade root portion and at its other end with said projection and movable bodily with said blade as the 45 latter moves about said drag hinge for effecting a locking connection between said projection and said depending portion and preventing upward flapping of said blade when the latter is rotating 50 below a predetermined R. P. M., and spring means carried by said root portion and bearing against said toggle for constantly biasing the latter toward blade locking position.

3. An anti-flapping lock for a helicopter rotor 55 having a hub and a blade pivoted thereto on flapping and drag hinges, said lock comprising a centrifugally operated toggle having its ends pivotally connected to said flapping and drag hinges 60 respectively and bodily movable with said blade as the latter moves about said drag hinge, stop means on said drag hinge for arresting the inward swinging movement of said toggle in a slightly 65 over-center position, and spring means carried by said flapping hinge and engageable with said toggle for constantly biasing the latter into said over-center position.

4. A centrifugally operated anti-flapping lock 70 for a helicopter rotor having a hub, a drag hinge pivoted on said hub, a flapping hinge pivoted on said drag hinge and a blade mounted on said flapping hinge, said lock comprising two toggle 75 links having a common pivotal connection at one end and having their free ends pivotally connected to said flapping and drag hinges respectively, said toggle being movable with the blade as the latter flaps upwardly between a straight-

6

ened position in which the blade is locked against upward flapping and a broken position permitting blade flapping, stop means engageable by one of said links for arresting said toggle links in said 5 straightened position, and spring means carried by said flapping hinge and engageable with one of said toggle links for constantly urging said links toward said straightened position.

5. In a helicopter rotor, a hub rotatable about 10 an upright axis, a drag hinge pivoted to said hub, a blade pivoted to said drag hinge for flapping movements, and means bodily movable with said blade as the latter moves about its drag 15 pivot for locking said blade against upward flapping movement whenever the speed of the rotor is below a predetermined R. P. M. including a locking toggle having its extremities connected between said drag hinge and said blade, said 20 toggle occupying a substantially on-center upright position when said rotor speed is below said predetermined R. P. M. and having centrifugal force responsive means adjacent its common pivot for breaking said toggle when said hub is rotated 25 above said speed to unlock said blade for upward flapping movement.

6. A centrifugally operated anti-flapping lock 30 for a helicopter rotor having a hub, a drag hinge pivoted on said hub, a flapping hinge pivoted on said drag hinge and a blade mounted on said flapping hinge, said drag hinge having a portion 35 extending outboard beneath said flapping hinge, said lock comprising two toggle members pivotally connected together at adjacent ends and adapted when in position to lock said flapping 40 hinge to lie in a collapsed over-center position, means pivotally connecting the free end of one member with said extension, means pivotally 45 connecting the free end of the other member with said flapping link, stop means on said drag hinge engageable with one of said toggle members for arresting said toggle members in said 50 collapsed position with the common pivot of said toggle members located slightly inward beyond a line intersecting both pivotal connections for the ends of said toggle members, and spring means 55 carried by said flapping hinge and acting on one member of said toggle for constantly urging said toggle into engagement with said stop means.

7. In a helicopter having a rotatable hub and 60 a blade pivoted to said hub for flapping movement, said blade being connected to said hub by pivoted drag and flapping hinges, means operable in response to the speed of rotation of said 65 hub for limiting flapping movement of said blade about its flapping hinge comprising toggle mechanism connected between said flapping and drag 70 hinges and movable bodily with said blade as it pivots about the latter and movable between a slightly over-center locked position and a broken 75 unlocked position concurrently with flapping movements of said blade, stop means on said drag hinge for arresting said toggle in said over-center position, and means carried by said flapping hinge and acting on said toggle for constantly biasing said toggle mechanism into blade 80 locked position against said stop means, said toggle having centrifugal force responsive means for overcoming said biasing means and moving 85 said toggle into unlocked position when said hub attains a predetermined speed to release said blade for flapping movement.

8. In a helicopter, a rotor hub, a drag hinge 90 pivoted on said hub for movement about a generally vertical axis, a flapping hinge pivoted on said drag hinge for movement about a generally

7

horizontal axis, said drag hinge having a depending extension which lies beneath said flapping hinge, and centrifugally operated locking means including a toggle connected between said extension and said flapping hinge and movable out of locking position with said blade as the latter flaps upwardly for positively locking said blade against upward flapping movement whenever said rotor is turning below a predetermined R. P. M.

9. In a helicopter, a rotor hub, a drag hinge pivoted on said hub for movement about a generally vertical axis, a flapping hinge pivoted on said drag hinge for movement about a generally horizontal axis, said drag hinge having a depending extension which lies beneath said flapping link, a toggle mechanism having its extremities

8

pivotaly connected to said extension and to said flapping link respectively, and spring means carried by said flapping hinge and engageable with said toggle mechanism for normally biasing said mechanism to an on-center locking position.

MICHEL D. BUIVID.

REFERENCES CITED

10 The following references are of record in the file of this patent:

UNITED STATES PATENTS

Number	Name	Date
2,475,333	Morris	July 5, 1949
2,549,887	Buivid	Apr. 24, 1951