

E. P. BERGMAN & A. E. RENARD.

BUCKLE.

(Application filed June 18, 1901.)

(No Model.)

Fig. 1.

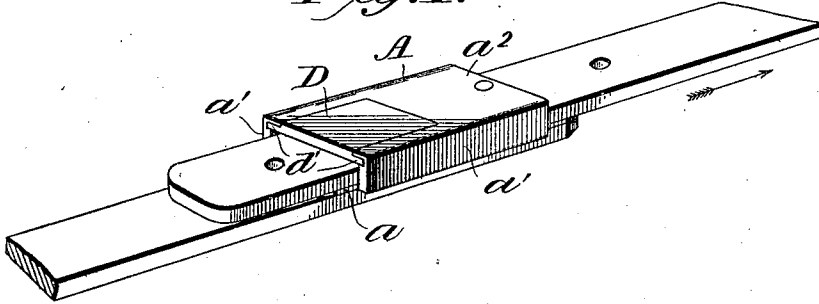

Fig. 2.

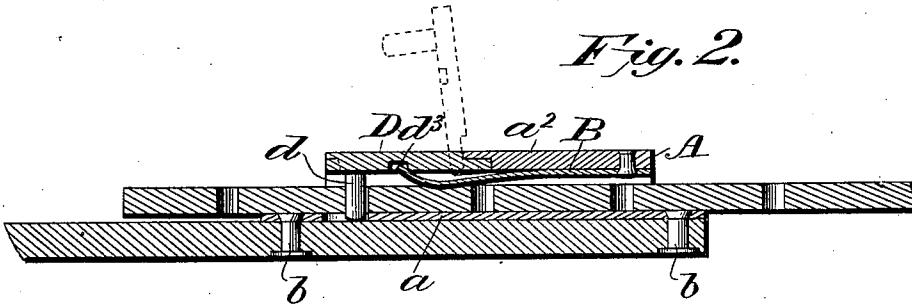

Fig. 4.

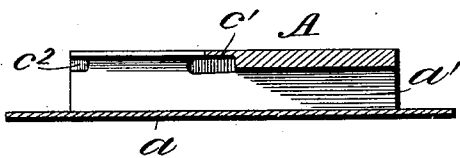

Fig. 3.

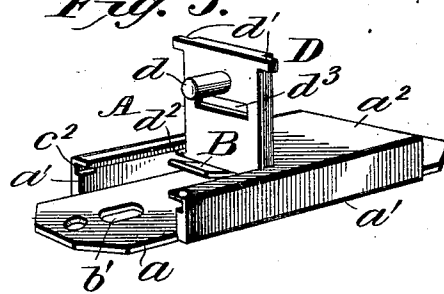
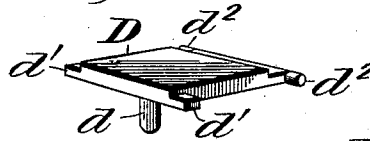

Fig. 5.



WITNESSES:

*C. H. Walker*  
*H. H. Johnson*

INVENTORS

*E. P. Bergman*  
*A. E. Renard*

BY *Eugene M. Johnson*  
 Attorney

# UNITED STATES PATENT OFFICE.

ERICK P. BERGMAN AND ARTHUR E. RENARD, OF CONCORDIA, KANSAS.

## BUCKLE.

SPECIFICATION forming part of Letters Patent No. 680,370, dated August 13, 1901.

Application filed June 18, 1901. Serial No. 65,029. (No model.)

*To all whom it may concern:*

Be it known that we, ERICK P. BERGMAN and ARTHUR E. RENARD, citizens of the United States, residing at Concordia, in the county of Cloud and State of Kansas, have invented new and useful Improvements in Buckles, of which the following is a specification.

This invention relates to certain new and useful improvements in buckles, the object being to provide a buckle which is simple in construction and when applied will have no projecting parts, the same being designed particularly as a trace or hame-tug buckle; and the invention consists in the construction and combination of the parts, which includes an open-ended frame or box to which one of the straps is attached, the other strap being adapted to be adjustably secured within the box by a pivoted and sliding tongue-piece, the box being provided with a spring which is adapted to swing the tongue-piece upon its pivot, as will be hereinafter set forth.

In the accompanying drawings, which illustrate the invention, Figure 1 is a perspective view showing two straps connected by the improved buckle. Fig. 2 is a longitudinal sectional view, the tongue-piece being shown elevated in dotted lines. Fig. 3 is a perspective view of the buckle with the tongue-piece raised. Fig. 4 is a sectional view of the frame or box, and Fig. 5 is a detail perspective view of the tongue-piece.

The box or frame A has a base-piece *a*, with projecting ends which are perforated for the reception of rivets *b b*, which are used to connect a hame-tug or other strap to the buckle, and from the base-piece project the sides *a'* and a partial top *a<sup>2</sup>*. The sides *a'* beyond the partial top extend inward, and beneath the inward-extending portion and the end of the top *a<sup>2</sup>* are slotted bearings *c'*, in which are adapted to be placed so as to be susceptible of a longitudinal movement the lugs or pivots which project from the sides of the tongue-carrying piece, and at the front end of the box-frame on a line with the slotted bearings are recesses *c<sup>2</sup>*, which receive lugs at the front end of the tongue-piece. On a line with the front end of the side pieces of the buckle is a slot *b'*, with which the tongue of the buckle may engage, and to the

rear end of the upper side of the top is secured by means of a rivet or otherwise a spring B. It will be noted that the buckle is constructed so as to provide a top piece which is reduced in thickness at its front end, and the upper ends of the sides extend slightly inward.

The part A of the buckle may be made up of a single piece, and the spring B, which is carried thereby, has its front end curved upward.

D refers to the tongue-piece, which carries near its front end a tongue *d*, and from the sides of the tongue-piece project lugs *d'* and pivots *d<sup>2</sup>*, the rear edge slightly in advance of the pivot being cut away or reduced in thickness, so as to lie under the front portion of the top of the box-frame when the tongue-piece is on a line with the top. The under side of the tongue-piece has a transverse recess *d<sup>3</sup>*, with which the free end of the spring engages when the tongue-piece is lowered.

When the tongue-piece D is raised, as shown in Fig. 3, a strap may be passed into the box-frame, and the tongue-piece when depressed can be placed in engagement with one of the perforations through the strap. Then by drawing the strap in the direction of the arrow, Fig. 1, and at the same time bearing upon the tongue-carrying piece the lugs will be passed into the recesses *c<sup>2</sup>*, and thus the straps will be securely connected. To release or throw the tongue-carrying piece out of engagement with the front end of the box-frame, it is only necessary to draw upon the front end of the strap, as such pressure will cause the pivots to move forward in their slotted bearings, and when so moved the lugs will be disengaged from the recesses *c<sup>2</sup>*, and when so disengaged the spring will throw the tongue-piece upward and out of engagement with the strap. The spring then engaging the end of the tongue-piece will hold it inclined. The parts of the buckle are so constructed that there are no projecting parts, and said buckle may be ornamented as desired.

Having thus described the invention, what we claim as new, and desire to secure by Letters Patent, is—

1. In a buckle, the combination with a box-frame having a partially cut-away top and open ends, the side pieces having elongated

bearings, a spring carried by the top, of a plate having a tongue and at its sides pivots which engage the elongated slots, and lugs which engage the front of the box-frame, substantially as shown and for the purpose set forth.

2. In a buckle, the combination with an open-ended box-frame, of a tongue-carrying piece pivotally connected thereto so as to be susceptible of a longitudinal movement the tongue-piece having near its front end laterally-projecting lugs for retaining the tongue-carrying piece on a line with the upper side of the box-frame, substantially as shown.

3. In a buckle the combination of a box-frame comprising a base-plate having a slot

therethrough, side pieces which are cut away to provide near the ends recesses, elongated bearings adjacent to the partial top of the box-frame, a spring carried by said partial top so that its free end will project beyond the same, a tongue-carrying piece having a tongue and at its ends laterally-projecting pivots and lugs, substantially as shown.

In testimony whereof we have hereunto set our hands in presence of two subscribing witnesses.

ERICK P. BERGMAN.  
ARTHUR E. RENARD.

Witnesses:

W. W. BAUMAN,  
H. C. WONES.