

DAVIES COLLISON CAVE
10 Barrack St., Sydney, 2000, Australia
Telephone 02 2622611 Patent Office Speed Dial 510

Our Ref: 346097/AJC

P/00/008
Section 29(1)
Regulation 3.1(2)

AUSTRALIA

Patents Act 1990

644794

NOTICE OF ENTITLEMENT

T.D. PREECE & CO. PTY. LTD., of 265 Condamine Street, Manly Vale, New South Wales, 2093, Australia, the Applicant/Nominated Person in respect of Australian Patent Application No. 57350/90 state the following:-

The Nominated Person is entitled to the grant of the patent because the Nominated Person has entitlement from the actual inventor KIM PREECE by assignment.

The Nominated Person is entitled to claim priority from the basic application listed in the declaration under Article 8 of the PCT because the Nominated Person made the application listed in the declaration under Article 8 of the PCT, and because the application is the first application made in a Convention country in respect of the invention.

DATED this 1st day of November 1993.

.....
a member of the firm of
DAVIES COLLISON CAVE for
and on behalf of the applicant(s).



(11) AU-B-57350/90
(10) 644794

-2-

normally closing said valve and said poppet when urged against said bias opening said flow path, means connecting said diaphragm and said poppet for moving said poppet responsive to said diaphragm; and, first and second air baffles on or integral with said elongated member, the first of which baffles is located at the first end of the elongated member and the second of which is located intermediate said ends wherein, the second baffle is larger than the first baffle and air entering the flow path impinges on then by passes the first baffle thence impinges on the second baffle before exiting the valve towards the mouth of a user, the combined effect of the air on said baffles urging said poppet away from the air inlet and wherein when air is demanded by a user of the regulator, the diaphragm activates the connecting means to urge the poppet away from the said inlet, wherein air travels through said valve and creates a dynamic force which continually impinges upon said baffles thereby assisting opening of the valve and allowing a reduced but constant inhalation effort by the user required to operate the valve upon demand for air.

12. A breathing regulator for use in underwater breathing comprising;

a primary housing with a breathing chamber, a valve enabling travel of air upon demand by a user from an inlet to an outlet in the valve thence to an outlet in the housing via a mouth piece to the lungs of a user,

a movable diaphragm for creating a vacuum in the housing in response to user demand for air, characterised in that said valve across said housing comprises:

a flow path within the valve between the inlet and outlet, a poppet slidably mounted in said flow path to open and close said flow path, said poppet including an elongated member having first and second ends; means for providing a bias on said poppet to close said flow path, said poppet

(11) AU-B-57350/90
(10) 644794

-3-

when urged by said bias operative to maintain said poppet normally closing said valve and said poppet when urged against said bias opening said flow path, means connecting said diaphragm and said poppet for moving said poppet responsive to said diaphragm; and, first and second air baffles on or integral with said elongated member, the first of which baffles is located at the first end of the elongated member and the second of which is located intermediate said ends wherein, the second baffle is larger than the first baffle and air entering the flow path impinges on then by passes the first baffle thence impinges on the second baffle before exiting the valve towards the mouth of a user, the combined effect of the air on said baffles urging said poppet away from the air inlet and wherein when air is demanded by a user of the regulator, the diaphragm activates the connecting means to urge the poppet away from the said inlet, wherein air travels through said valve and creates a dynamic force which continually impinges upon said baffles thereby assisting opening of the valve and allowing a reduced but constant inhalation effort by the user required to operate the valve upon demand for air;

a venturi assisted air directing means comprising an opening in the body of the valve and a rotatable concentric sleeve disposed about the valve body and also having an opening therein which selectively partly or wholly aligns with the opening in the valve to either direct or throttle air to the mouthpiece via the shortest distance, inhibit or prevent the free flow of air through the regulator according to which direction and the degree to which the concentric sleeve is rotated relative to the valve.

INTERNATIONAL APPLICATION PUBLISHED UNDER THE PATENT COOPERATION TREATY (PCT)

<p>International Patent Classification ⁵ : B63C 11/22</p>	<p>A1</p>	<p>(11) International Publication Number: WO 90/14990 (43) International Publication Date: 13 December 1990 (13.12.90)</p>
<p>(21) International Application Number: PCT/AU90/00249 (22) International Filing Date: 6 June 1990 (06.06.90) (30) Priority data: PJ 4577 6 June 1989 (06.06.89) AU (71) Applicant (for all designated States except US): T.D. PREECE & CO. PTY. LTD. [AU/AU]; 265 Condamine Street, Manly Vale, NSW 2093 (AU). (72) Inventor; and (75) Inventor/Applicant (for US only): PREECE, Kim [AU/AU]; 265 Condamine Street, Manly Vale, NSW 2093 (AU). (74) Agent: TAYLOR, Paul, Robert; Arthur S. Cave & Co., Level 10, 10 Barrack Street, Sydney, NSW 2000 (AU).</p>	<p>(81) Designated States: AT, AT (European patent), AU, BE, BE (European patent), BF (OAPI patent), BG, BJ (OAPI patent), BR, CA, CF (OAPI patent), CG (OAPI patent), CH, CH (European patent), CM (OAPI patent), DE*, DE (European patent)*, DK, DK (European patent), ES, ES (European patent), FI, FR (European patent), GA (OAPI patent), GB, GB (European patent), HU, IT (European patent), JP, KP, KR, LK, LU, LU (European patent), MC, MG, ML (OAPI patent), MR (OAPI patent), MW, NL, NL (European patent), NO, RO, SD, SE, SE (European patent), SN (OAPI patent), SU, TD (OAPI patent), TG (OAPI patent), US. Published With international search report.</p> <p style="font-size: 2em; text-align: center;">644794</p>	

(54) Title: DIVING REGULATOR DEMAND VALVE

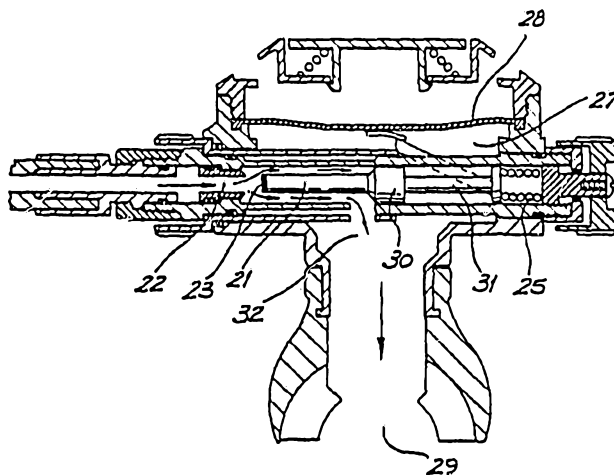

(57) Abstract

A regulator for use in underwater breathing comprises a primary housing with a breathing chamber and a demand valve (20) enabling flow of air, upon demand by a user, from an inlet orifice (22) to an outlet (16) in the valve (20) and then to an outlet (32) in the primary housing and then via a mouthpiece (29) to the lungs of a user. The valve (20) comprises a slidably mounted poppet (21) one end (23) of which is urged against orifice (22) by a biasing spring (25). Movable diaphragm (28) in response to demand for air draws end (23) of the poppet away from the orifice (22) against the force of the biasing spring (25) allowing the flow of air. An air baffle (30) is located on the poppet intermediate its ends and the air flowing through the valve continuously impinges on the baffle (30) urging the poppet away from the orifice (22) thereby reducing the effort of the user to operate the valve upon demand for air.

* See back of page

- 1 -

DIVING REGULATOR DEMAND VALVE

The present invention relates to self contained underwater breathing apparatus and more specifically relates to improvements in regulators associated therewith whereby the breathing characteristics in a regulator are altered so as to reduce the inhalation effort required by a user upon demand for air. The alteration in the breathing characteristics is effected according to the present invention by adjustments to the demand valve in the regulator.

Regulators are well known in the diving industry as a crucial component of the apparatuses required. A regulator acts in concert with a pressure reducing valve and as a means for regulation of air for a diver. The pressure reduction activity is known as the first stage of regulation and this involves the reduction in air pressure between the air tank and the regulator. The supply of air upon demand by a diver passes through the first stage thence through a second stage.

It is the second stage of operation to which the present invention is primarily directed.

The second stage of operation is controlled by a demand valve which is located near the air discharge end of the regulator which comprises a mouthpiece.

It is one object of the present invention to reduce the effort required on the part of the user of the regulator upon demand for air.

Regulators are well known with numerous designs for these being readily available. In its most basic form a typical regulator comprises a housing having a mouthpiece and a demand valve which acts in concert with a vacuum assisted diaphragm located inside the housing. The diaphragm is, and consequently the demand valve, are operably responsive to demand for air. The demand valve is typically adapted with an internal element known as a poppet which is adapted to operate between a closed and open position in response to demand for air by a user.

- 2 -

The poppet when in the closed position, is urged against an air inlet hole in the valve under the assistance of a spring bias closing off the supply of air via the inlet. The compression force in the spring must
5 be at least slightly greater than the pressure exerted immediately upstream of the inlet orifice to enable the closing of the orifice.

The poppet moves from the closed configuration to an open configuration upon demand for air. When the poppet
10 is open unbalanced forces are generated due to the gradient of increasing effort required to overcome the increasing compressive force exerted by the spring bias when demand is made for air by the user.

When a user of a regulator demands air the initial
15 inhalation effort is called the cracking effort. That is, the effort required to move the sealing end of the poppet away from the air inlet. The cracking effort required is generally a function of the dynamic air pressure acting on the end of the poppet at the air inlet end of the valve
20 relative to the energy in the biasing spring coupled with the degree of vacuum required to overcome the counteracting spring force upon demand for air.

The air travel is also affected by a venturi effect created when air is demanded due to the high velocity of
25 the air.

The prior art poppet arrangement suffers from the major disadvantage that an unbalanced force regime is generated at the air entry orifice and within the valve chamber due to the prior art configuration of the typical
30 poppet.

In the prior art arrangement, when the diver breathes the forces become unbalanced due to the fact that the poppet is in the open position and also due to the fact that the line pressure of the air does not bear
35 sufficiently on the poppet to reduce breathing effort. In this case, full reliance must be placed on the vacuum to maintain the poppet in the open position. This requires

valves by providing a newly configured demand valve which results in balanced forces in the valve and a reduced effort on the part of the user when demanding air.

In a further improvement to the demand valve, the valve is adapted with a concentric sleeve operable by a knob external of the housing to enable adjustment by a user when in use of the air passage such that the vacuum can be cancelled to conserve air or to adjust venturi flow so as to direct air into the mouthpiece of the regulator. The prior art regulators could only be adjusted by use of a screw driver or like instrument.

In one broad form the present invention comprises a demand valve of the type comprising an air passage chamber, an inlet port and an outlet port and having disposed therein a poppet biased against the inlet port, characterised in that the poppet comprises a first flange and second flange for receiving line pressure and/or deflection of air passage, wherein when said demand valve is in use and vacuum assisted air from said inlet port impinges upon and is urged against said first means, air also from said inlet impinges on said second flange and is contemporaneously deflected by said second flange so that air leaves the said valve said outlet port thereby reducing the effort required by the user upon demand for air to overcome the biasing force.

In another form the invention comprises;

a breathing regulator for use in underwater breathing comprising;
a primary housing with a breathing chamber, a valve enabling travel of air upon demand by a user from an inlet to an outlet in the valve thence to an outlet in the housing via a mouth piece to the lungs of a user,
a movable diaphragm for creating a vacuum in the housing in response to user demand for air, characterised in that said valve across said housing comprises:

a flow path within the valve between the inlet and outlet, a poppet slidably mounted in said flow path to open and close said flow path, said poppet including an elongated member having first and second ends; means for providing a bias on said poppet to close said flow path, said poppet

when urged by said bias operative to maintain said poppet normally closing said valve and said poppet when urged against said bias opening said flow path, means connecting said diaphragm and said poppet for moving said poppet responsive to said diaphragm; and, first and second air baffles on or integral with said elongated member, the first of which baffles is located at the first end of the elongated member and the second of which is located intermediate said ends wherein, when air is demanded by a user of the regulator, the diaphragm activates the connecting means to urge the poppet away from the said inlet, wherein air travels through said valve and creates a dynamic force which continually impinges upon said baffles thereby assisting opening of the valve and reducing the inhalation effort of the user required to operate the valve upon demand for air;

a venturi assisted air directing means comprising an opening in the body of the valve and a rotatable concentric sleeve disposed about the valve body and also having an opening therein which selectively partly or wholly aligns with the opening in the valve to either direct or throttle air to the mouthpiece via the shortest distance, inhibit or prevent the free flow of air through the regulator according to which direction and the degree to which the concentric sleeve is rotated relative to the valve.

In its broadest form the present invention comprises;
a breathing regulator for use in underwater breathing through the mouth of a regulator user of the type comprising;
a primary housing with a breathing chamber having an inlet and an outlet, a valve enabling travel of air between said inlet and outlet upon demand by a user and thence from the housing via a mouth piece to the lungs of a user,
a movable diaphragm for creating a vacuum in the housing in response to user demand for air, characterised in that said valve across said housing comprises:

a flow path within the valve between the inlet and outlet, a poppet slidably mounted in said flow path to open and close said flow path, said poppet including an elongated member having first and second ends; means for providing a

bias on said poppet to close said flow path, said poppet when urged by said bias operative to maintain said poppet normally closing said valve and said poppet when urged against said bias opening said flow path, means connecting said diaphragm and said poppet for moving said poppet responsive to said diaphragm; and, first and second air baffles on or integral with said elongated member, the first of which baffles is located at the first end of the elongated member and the second of which is located intermediate said ends wherein, the second baffle is larger than the first baffle and air entering the flow path impinges on then by passes the first baffle thence impinges on the second baffle before exiting the valve towards the mouth of a user, the combined effect of the air on said baffles urging said poppet away from the air inlet and wherein when air is demanded by a user of the regulator, the diaphragm activates the connecting means to urge the poppet away from the said inlet, wherein air travels through said valve and creates a dynamic force which continually impinges upon said baffles thereby assisting opening of the valve and allowing a reduced but constant inhalation effort by the user required to operate the valve upon demand for air.

In the preferred embodiment the demand valve also comprises a sleeve which is concentric about the air passage chamber. The purpose of the sleeve is to facilitate more efficient air delivery to the user following exiting of the air from the housing. The drum also enables selective control of air by the user external of the housing to either enhance the venturi flow of air on to cancel the effect of the vacuum according to user requirements.

The invention will now be described in more detail according to a preferred but non limiting embodiment and with reference to the accompanying illustrations wherein;

Figure 1 shows an abbreviated longitudinal sectional view of a prior art demand valve with the valve poppet shown in the closed configuration,

Figure 2 shows an abbreviated longitudinal sectional view of a prior art demand valve with the valve poppet shown in the open configuration,

Figure 3 shows an abbreviated longitudinal sectional view of a demand valve according to one embodiment of the present invention with the valve poppet shown in the closed position,

Figure 4 shows an abbreviated longitudinal sectional view

of a demand valve according to one embodiment of the present invention with the valve poppet shown in the open position,

Figure 5 shows a cross sectional plan view of a regulator with demand valve and with the poppet in the closed configuration.

Figure 6 shows a cross sectional plan view of a regulator with demand valve and with the poppet in the open

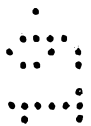

- 6 -

demand valve with poppet 5 contained therewithin draws
breath in order to obtain air, a vacuum is created which
causes a diaphragm to engage with lever 18 to enable air
to pass into the chamber 7. At the same time the poppet 5
5 is drawn back against the spring bias allowing the air to
pass through the chamber 7 and exit via opening 4. At
this moment the demand valve force regime becomes
unbalanced because the spring bias force gradually
increases due to increasing compression of the spring.
10 This has a resultant effect of decreasing the opposing air
inlet line force on poppet 5 generated by the ingress of
air through opening 3. This consequently results in a
decrease in the air pressure on the poppet. This is also
exacerbated by the effect that air is at the same time
15 escaping through outlet opening 4. As a result of this
force regime, the effort in order to maintain air flow
during the activity of drawing breath to demand air
gradually increases over a gradient thereby requiring
greater force to be exerted to maintain the poppet 5 in
20 the open position. This occurs at the time when the
energy of the user during inhalation is at its weakest;
that is at the end of the inhalation.

It is therefore desirable to provide a demand valve
having improved facility for creating a reduction in
25 effort necessary to be exerted by a user upon demand for
air.

Figure 3 shows a portion of a demand valve according
to the preferred embodiment of the present invention
showing a newly configured poppet valve 10 and an
30 externally adjustable outer concentric sleeve 17 which
assists in directing air flow to the mouth of the user.

The demand valve of figure 3 comprises a valve
housing 8 having there within an inlet orifice 9 similar
to the inlet orifice 3 of the prior art valve in figure
35 1. The valve also contains a poppet 10 which is urged
against the orifice of inlet opening 9 under the
assistance of biasing spring 11. The valve also has a

- 7 -

conventional lever 12 which is actuated by linkage to the valve and which is responsive to the action by vacuum assistance of a regulator diaphragm (see figures 5 and 6) upon demand for air by a user of the demand valve.

5 The demand valve of the present invention differs in one respect from the prior art according to one embodiment by firstly comprising a newly configured poppet 10. As can be seen from figure 3 the poppet 10 comprises an elongated shaft 13 having located thereon or thereabout a
10 first baffle or flange 14 and a second baffle or flange 15. The configuration of this poppet results in a change in the force regime which occurs around the poppet upon demand for air by a user of the demand valve. Figure 3 shows the demand valve according to the present invention
15 with the poppet in the closed position. When a user demands air, the action of the diaphragm in the regulator (not shown) causes arm 12 to allow passage of air through inlet opening 9. The configuration of the demand valve in the open position is shown in figure 4. When air is
20 demanded by a user, the air travels through passage 9 as previously stated. The passage of this air which is under pressure causes a number of effects. The first being counteraction of the force exerted by biasing spring 11, the second being the impingement of air upon the broad
25 face of wider flange or baffle 14 and a deflection of air around narrower flange or baffle 15.

The effect of the forces so generated cause an increase of and/or a maintenance of pressure in the flange or baffle 15 at the same time as deflection of air is
30 caused by and about flange 14. At this time air is also escaping via outlet orifice 16 located in the wall of the housing 8 and via orifice 19 located in concentric sleeve 17. The configuration of the poppet 10 is such that the air can only either escape through exit 16 or
35 alternatively impinge upon the surface of baffle 15. The impingement of the air on baffle 15 has the effect of countering the increase in the size of the biasing force

exerted by spring 14 as it is compressed under the action of the air pressure. The impinging air on baffle 15 also compensates for air loss through orifice 16. The overall result of this effect is to reduce the effort required by the user demanding air due to the air line forces being maintained on the poppet thereby enabling optimum force balance.

Referring to figure 5 there is shown a cross sectional plan view of a regulator having a demand valve 20 shown in the configuration commensurate with exhalation by a user. In this configuration the demand valve 20 is shown poppet 21 urged against orifice 22 such that the orifice 22 is sealed by poppet end 23. Line pressure from a supply tank (not shown) is exerted in supply line 24 usually the line pressure exerted in line 24 would be at or around 28 pounds force. In order to counteract this force, biasing spring 25 urges the end of the poppet 26 in a direction contrary to that exerted by the line pressure on the end 23 of the poppet 21.

Ideally the pressure exerted by the biasing spring 25 should be as close as possible to the line pressure but slightly above the line pressure so that when air is not demanded the poppet remains in the closed configuration.

Figure 6 shows the regulator of figure 5 this time in the air demand or inhalation configuration when a user demands air. Upon demand for air the end 23 of the poppet 21 is drawn away from the orifice under the assistance of the vacuum created in chamber 27 by diaphragm 28.

As the spring bias force is ideally slightly greater than the line pressure, a further effort is required to be exerted on the poppet 21 to move it away from the orifice 22 to thereby allow free flow of air to mouthpiece 29. In order to assist this process, the flange 30 which is located around the main shaft 31 of the poppet 21.

In the prior art poppet arrangement the line pressure had no effect in urging a force against the poppet once the poppet had released from the supply orifice.

- 9 -

According to the preferred embodiment of the present invention, the provision of the flange 31 provides a surface on which the incoming air can impinge thereby enabling retention of the line pressure on the poppet to
5 urge the poppet away from the inlet orifice thereby reducing the effort required by the user upon demand for air.

Although figures 5 and 6 show a flange on the poppet according to one embodiment it is envisaged that the
10 flange can be made up from one or more of a plurality of flanges provided obstruction is provided to the air incoming from the orifice 22 and passage via orifice 32 to the mouthpiece 29. Ideally the flange would be located when the poppet is in the fully open configuration at or
15 near orifice 32 so that air is contemporaneously impinging on the flange 31 and redirected via orifice 32 into the mouthpiece 29.

This results in the system having a balanced force regime in the valve and between the biasing force and the
20 line pressure impinging on the baffles thereby reducing the effort required by the user upon the demand for air. One advantage of the existence of the flange or baffle means on the poppet is that spring selection is not as critical as it has been in prior art valves when
25 unbalanced forces are introduced into the breathing system upon demand for air.

Thus, the line pressure which is exerted on the end 23 of the poppet 21 when in the closed position is maintained on the poppet but transferred when the poppet
30 is in the open position to impinge on flange 30. In addition to the altered configuration of the poppet valve, the improved valve also comprises a concentric sleeve 17 (see figures 3 and 4) adapted to concentrically rotate about housing 8. Alternatively, the housing 8 may
35 be fixedly attached to the sleeve 17 so that the whole demand valve portion can rotate as one. This allows the facility for directing the air towards the mouth piece of

- 10 -

the regulator thus facilitating improved passage of air and without the assistance of baffles as was required in the prior art.

Figure 7 shows an abbreviated cross sectional elevational view of the prior art configuration of the regulator showing a baffle used for deflection of air. The attitude of the baffle is selected according to the angle the air is to impinge on the baffle.

Figure 8 shows a cross sectional view of a regulator showing the venturi assist facility in the demand valve of the present invention located therein. Also in this regulator, it can be noted that the baffle is absent with the air being directed via rotational freedom of the demand valve so that the user may select the direction of air which leaves the demand valve, according to air demand requirements.

The disadvantage of the baffle arrangement for air delivery as shown in figure 7 in the cross section of the regulator is that the baffle or screen can work to obstruct the passage of air towards the mouth piece of the regulator. It can also result in drag on the air due to the change in direction thus slowing down entry of the air into the mouth piece of the regulator. This problem is overcome by the elimination of the baffle and also by the facility imparted to the demand valve of the present invention whereby it can be rotated within the regulator by external selective orientation of the directional passage of air towards the mouth piece of the regulator. With the rotational ability of the demand valve as shown in figure 6, it is possible that air could be directed anywhere within the range of 0 to 360° thereby resulting in freer passage of air to the mouth of a user.

Referring to figure 9 there is shown a side elevational cross sectional view of a regulator 33 having a demand valve 34 whereby air exists the demand valve in the direction of arrow 35 into the mouthpiece 36.

Figure 10 shows the regulator 33 this time with the

- 11 -

demand valve 34 reconfigured so that air travels in the direction of arrows 37 so that the vacuum effect created in chamber 38 by means of diaphragm 39 is counteracted. A control of the demand valve 34 is effected by means of a sleeve 40 which is operable by means of a knob 41 which is external to the regulator 33. This enables a user to alter the direction of air in the mouthpiece during use.

According to the prior art methodology, such adjustment could only be effected by using an instrument to gain access to the inside of the regulator to select a air direction configuration prior to use.

The demand valve arrangement of the present invention enables a user to make an air boost selection at any time during use by means of the external knob 41. This enhances a venturi effect of high velocity air when required and it may also counteract the vacuum effect created in chamber 38 by diaphragm 39 when a user demands air through the mouthpiece 36.

Thus, figure 9 shows the configuration of the demand valve 34 when maximum air delivery would be presented to mouthpiece 36.

Figure 9 shows the demand valve 34 with the configuration of sleeve 40, disposed so that air delivery to mouthpiece 36 is at a minimum. A selection of the configuration as shown in figure 10 would be likely to be made by an operator when less air is required.

Different users have different air requirements to maintain a comfortable breathing rate when diving. Thus, it is desirable to have a manual air delivery control which can be adjusted during use according to the particular circumstances.

As a diver dives deeper, the density of air increases necessitating ideally a facility for compensating adjustment to the air delivery. The improvement to the demand valve 34 enables this to be achieved. Also, the adjustment enables unwanted free flow of air to be prevented or minimised where necessary.

- 12 -

Furthermore, it has been found by divers that too much air can lead to nausea and discomfort when diving. The improvement to the demand valve can stop this by restricting the amount of air free flowing to the user
5 thus, the valve can be adjusted to personal requirements according to air demand.

It will be recognised by persons skilled in the art that numerous variations and modifications may be made to the present invention without departing from the overall
10 spirit and scope of the invention as broadly described herein.

The claims defining the invention are as follows:

1. A breathing regulator for use in underwater breathing through the mouth of a regulator user of the type comprising; a primary housing with a breathing chamber having an inlet and an outlet, a valve enabling travel of air between said inlet and outlet upon demand by a user and thence from the housing via a mouth piece to the lungs of a user, a movable diaphragm for creating a vacuum in the housing in response to user demand for air, characterised in that said valve across said housing comprises:

a flow path within the valve between the inlet and outlet, a poppet slidably mounted in said flow path to open and close said flow path, said poppet including an elongated member having first and second ends; means for providing a bias on said poppet to close said flow path, said poppet when urged by said bias operative to maintain said poppet normally closing said valve and said poppet when urged against said bias opening said flow path, means connecting said diaphragm and said poppet for moving said poppet responsive to said diaphragm; and, first and second air baffles on or integral with said elongated member, the first of which baffles is located at the first end of the elongated member and the second of which is located intermediate said ends wherein, the second baffle is larger than the first baffle and air entering the flow path impinges on then by passes the first baffle thence impinges on the second baffle before exiting the valve towards the mouth of a user, the combined effect of the air on said baffles urging said poppet away from the air inlet and wherein when air is demanded by a user of the regulator, the diaphragm activates the connecting means to urge the poppet away from the said inlet, wherein air travels through said valve and creates a dynamic force which continually impinges upon said baffles thereby assisting opening of the valve and allowing a reduced but constant inhalation effort by the user required to operate the valve upon demand for air.

2. A regulator according to claim 1 wherein the said first end of said poppet operates to alternatively prevent and allow passage of air from an inlet line to a chamber in said

valve responsive to demand for air.

3. A regulator according to claim 2 wherein the said second end which engages with the lever arm is adapted to engage said means for connecting said diaphragm and poppet with a lever arm which operates the poppet in response to movement of said vacuum dependent diaphragm.

4. A regulator according to claim 3, wherein, when the poppet is in the fully open position said baffles are located at or near said valve outlet so that air continues to impinge on said baffles immediately prior to exiting from said outlet thereby creating a balance between the biasing force and the line pressure force in said valve.

5. A regulator according to claim 4 wherein the air impinges predominately on the leading surface of each of said baffles.

6. A regulator according to claim 5 wherein the bias is created by a helical spring.

7. A regulator according to claim 6 wherein the biasing spring is concentric with a portion of said poppet and engages a surface on one of said baffles.

8. A regulator according to claim 7 wherein the biasing spring engages the second end of said poppet.

9. A regulator according to claim 8 wherein the said first end comprises a baffle having an area less than the cross sectional area of the chamber in said valve but greater in area than the cross sectional area of the air inlet to thereby act as a closure for said inlet when said poppet is in the closed position and as an air baffle when said poppet is in the open position.

10. A regulator according to claim 9 wherein the said first end is adapted with sealing means to seal said inlet when said poppet is in the closed position.

11. A regulator according to any one of the foregoing claims wherein the regulator valve also comprises a venturi assisted air directing means comprising an opening in the body of the valve and a rotatable concentric sleeve disposed about the valve body and also having an opening therein which selectively partly or wholly aligns with the opening in the valve to either direct or throttle air to the



mouthpiece via the shortest distance, inhibit or prevent the free flow of air through the regulator according to which direction and the degree to which the concentric sleeve is rotated relative to the valve.

12. A breathing regulator for use in underwater breathing comprising;

a primary housing with a breathing chamber, a valve enabling travel of air upon demand by a user from an inlet to an outlet in the valve thence to an outlet in the housing via a mouth piece to the lungs of a user,

a movable diaphragm for creating a vacuum in the housing in response to user demand for air, characterised in that said valve across said housing comprises:

a flow path within the valve between the inlet and outlet, a poppet slidably mounted in said flow path to open and close said flow path, said poppet including an elongated member having first and second ends; means for providing a bias on said poppet to close said flow path, said poppet when urged by said bias operative to maintain said poppet normally closing said valve and said poppet when urged against said bias opening said flow path, means connecting said diaphragm and said poppet for moving said poppet responsive to said diaphragm; and, first and second air baffles on or integral with said elongated member, the first of which baffles is located at the first end of the elongated member and the second of which is located intermediate said ends wherein, the second baffle is larger than the first baffle and air entering the flow path impinges on then by passes the first baffle thence impinges on the second baffle before exiting the valve towards the mouth of a user, the combined effect of the air on said baffles urging said poppet away from the air inlet and wherein when air is demanded by a user of the regulator, the diaphragm activates the connecting means to urge the poppet away from the said inlet, wherein air travels through said valve and creates a dynamic force which continually impinges upon said baffles thereby assisting opening of the valve and allowing a reduced but constant inhalation effort by the user required to operate the valve upon demand for air;

a venturi assisted air directing means comprising an opening in the body of the valve and a rotatable concentric sleeve disposed about the valve body and also having an opening therein which selectively partly or wholly aligns with the opening in the valve to either direct or throttle air to the mouthpiece via the shortest distance, inhibit or prevent the free flow of air through the regulator according to which direction and the degree to which the concentric sleeve is rotated relative to the valve.

13. A regulator according to claim 12 wherein the concentric sleeve is operable via a knob external of the regulator.

14. A regulator according to claim 13 wherein the selective adjustment of the mechanical sleeve via said knob alters the direction of the air either towards or away from the mouthpiece of the regulator.

15. A regulator according to claim 14 wherein the concentric sleeve is made from a plastics material.

16. A regulator according to claim 15 wherein the said knob has associated therewith gradations indicating the available settings for said concentric sleeve.

17. A regulator according to claim 16 wherein the said first end of said poppet operates to alternatively prevent and allow passage of air from an inlet line to a chamber in said valve responsive to demand for air.

18. A regulator according to claim 17 wherein the said second end is adapted to engage with a lever arm which operates said poppet in response to movement of said vacuum dependent diaphragm.

19. A regulator according to claim 18 wherein the poppet has two spaced apart baffles disposed approximately midway between the ends of said poppet.

20. A regulator according to claim 19, wherein, when the poppet is in the fully open position said baffle or baffles are located at or near said valve outlet so that air continues to impinge on said baffles immediately prior to exiting from said outlet thereby creating a balance between the biasing force and the line pressure force in said valve.

21. A regulator according to claim 20 wherein the air

impinges predominately on the loading surface of each of said at least one baffle/s.

22. A regulator according to claim 21 wherein the bias is created by a helical spring.

23. A regulator according to claim 22 wherein the biasing spring is concentric with a portion of said poppet and engages a surface on one of said baffles.

24. A regulator according to claim 23 wherein the biasing spring engages the second end of said poppet.

25. A regulator according to claim 24 wherein the said first end comprises a baffle having an area less than the cross sectional area of the chamber in said valve but greater in area than the cross sectional area of the air inlet to thereby act as a closure for said inlet when said poppet is in the closed position and as an air baffle when said poppet is in the open position.

26. A regulator according to claim 25 wherein the said first end is adapted with sealing means to seal said inlet when said poppet is in the closed position.

DATED this 1st day of November, 1993.

T.D. PREECE & CO. PTY. LTD.
By Its Patent Attorneys
DAVIES COLLISON CAVE

1/3

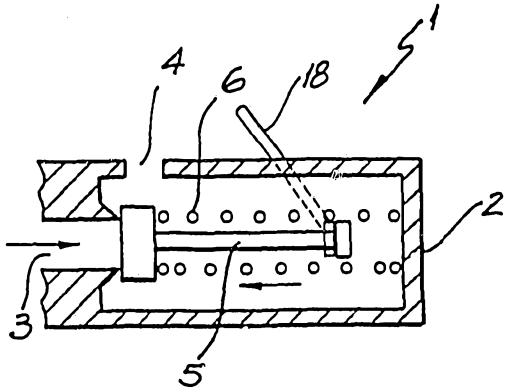

FIG. 1

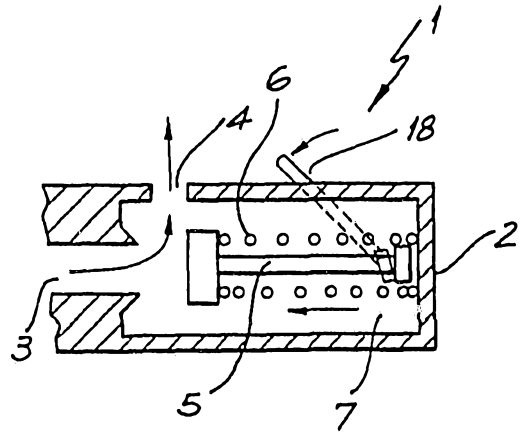

FIG. 2

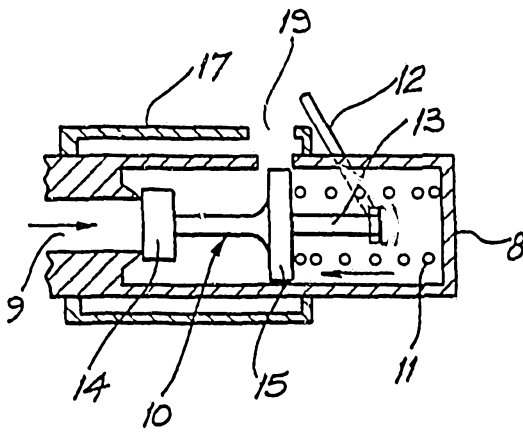

FIG. 3

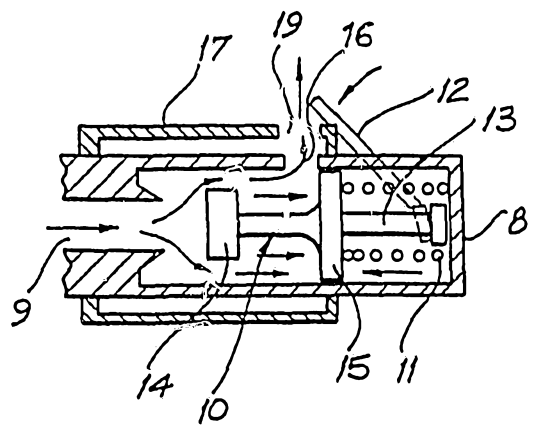

FIG. 4

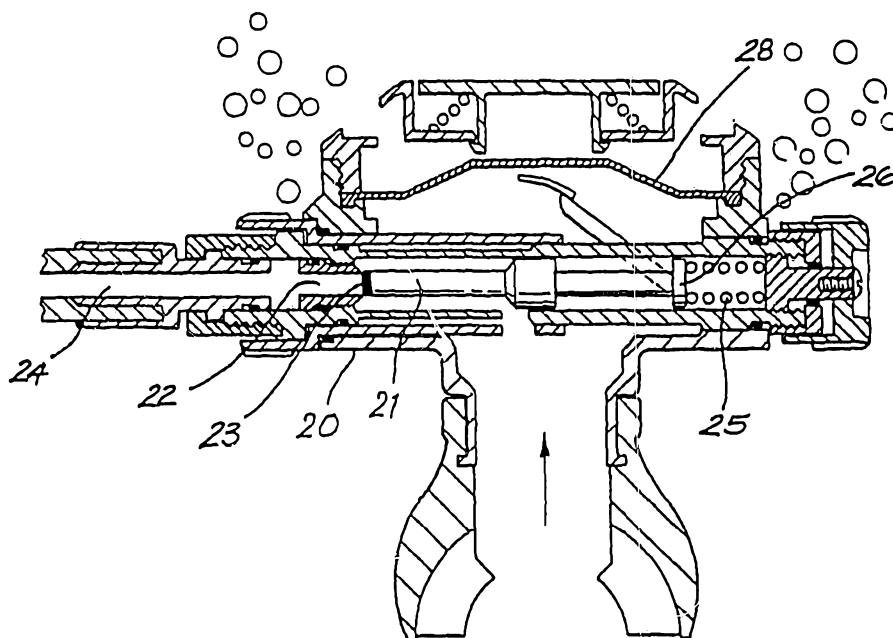

FIG. 5

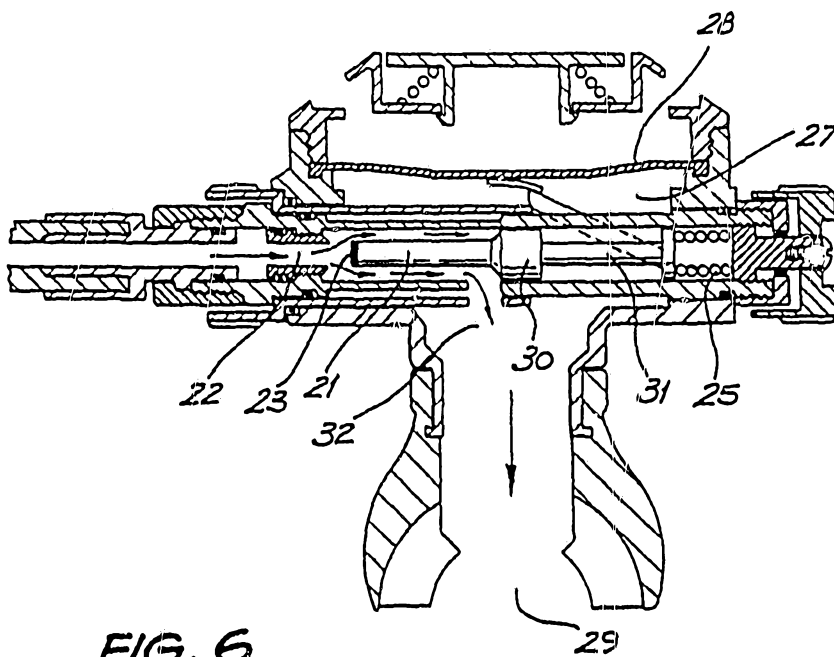

FIG. 6

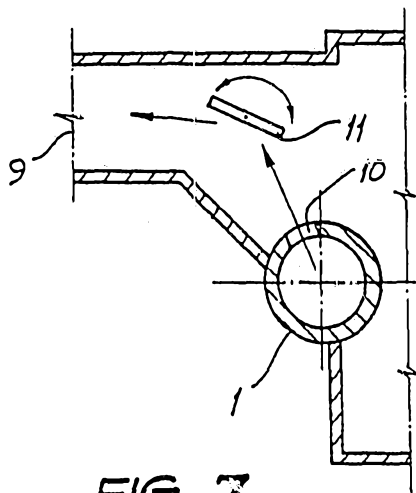

FIG. 7

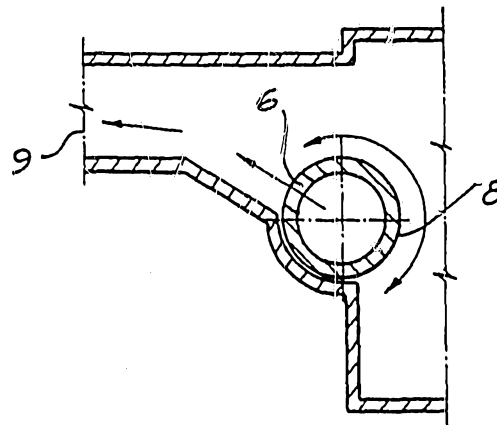

FIG. 8

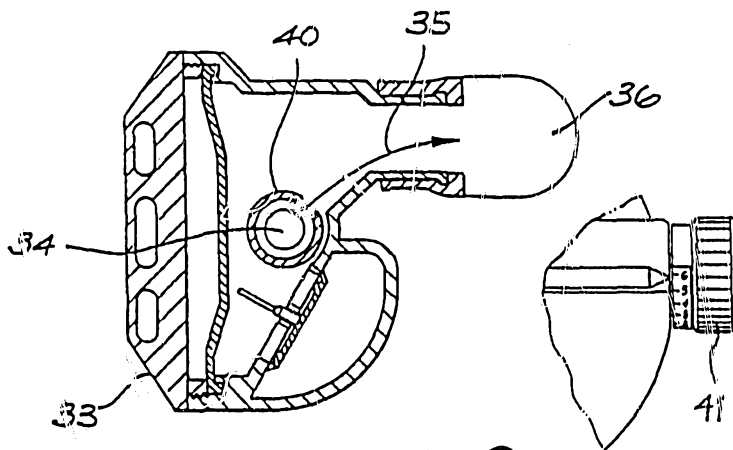

FIG. 9

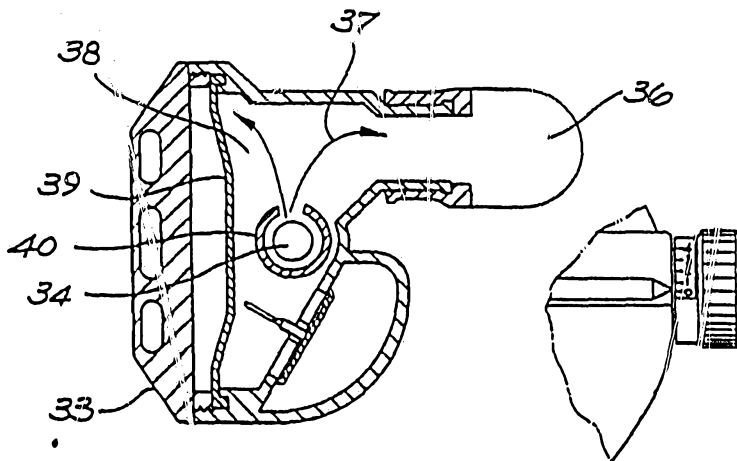
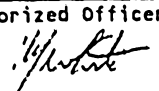

FIG. 10

INTERNATIONAL SEARCH REPORT

International Application No. PCT/AU 90/00249

I. CLASSIFICATION OF SUBJECT MATTER (if several classification symbols apply, indicate all) 6		
According to International Patent Classification (IPC) or to both National Classification and IPC		
Int. Cl. ⁵ B63C 11/22		
II. FIELDS SEARCHED		
Minimum Documentation Searched 7		
Classification System	Classification Symbols	
IPC	B63C 11/22, A62B 9/02	
Documentation Searched other than Minimum Documentation to the extent that such Documents are Included in the Fields Searched 8		
AU: IPC as above		
III. DOCUMENTS CONSIDERED TO BE RELEVANT 9		
Category*	Citation of Document, ¹¹ with indication, ¹² where appropriate, of the relevant passages	Relevant to Claim No 13
X	US,A, 3028860 (GAGNAN) 10 April 1962 (10.04.62) - Column 1 line 46 to column 2 line 21	1, 2, 3
X	US,A, 2695609 (NOURSE) 30 November 1954 (30.11.54) - Column 1 line 74 to column 2 line 56	1, 2, 3
X	CH,A, 194284 (DEGEA AKTIENGESSELLSCHAFT) 1 March 1938 (01.03.38) - Column 3 line 15 to end of column 4	1, 2, 3
X	US,A, 4076041 (CHRISTIANSOHN) 28 February 1978 (28.02.78) - Column 7 line 47 to column 8 line 21 Figures 8-10	1
X,P	US,A, 4889115 (BOZANO) 26 December 1989 (26.12.89) - Column 1 line 53 to Column 2 line 44	1
A	US,A, 4834086 (GAROFALO) 30 May 1989 (30.05.89)	
A	CH,A, 216130 (DRAGER) 17 November 1941 (17.11.41)	
A	CH,A, 466051 (STIRNEMANN) 15 January 1969 (15.01.69)	
<p>* Special categories of cited documents: 10 "T" later document published after the international filing date or priority date and not in conflict with the application but cited to understand the principle or theory underlying the invention</p> <p>"A" document defining the general state of the art which is not considered to be of particular relevance</p> <p>"E" earlier document but published on or after the international filing date</p> <p>"L" document which may throw doubts on priority claim(s) or which is cited to establish the publication date of another citation or other special reason (as specified)</p> <p>"O" document referring to an oral disclosure, use, exhibition or other means</p> <p>"P" document published prior to the international filing date but later than the priority date claimed</p> <p>"X" document of particular relevance; the claimed invention cannot be considered novel or cannot be considered to involve an inventive step</p> <p>"Y" document of particular relevance; the claimed invention cannot be considered to involve an inventive step when the document is combined with one or more other such documents, such combination being obvious to a person skilled in the art.</p> <p>"&" document member of the same patent family</p>		
IV. CERTIFICATION		
Date of the Actual Completion of the International Search 29 August 1990 (29.08.90)	Date of Mailing of this International Search Report 6 September 1990	
International Searching Authority Australian Patent Office	Signature of Authorized Officer P J WHITE 	

ANNEX TO THE INTERNATIONAL SEARCH REPORT ON
INTERNATIONAL APPLICATION NO. PCT/AU 90/00249

This Annex lists the known "A" publication level patent family members relating to the patent documents cited in the above-mentioned international search report. The Australian Patent Office is in no way liable for these particulars which are merely given for the purpose of information.

Patent Document Cited in Search Report	Patent Family Members			
US 4076041	FR 2285154	FR 2285155	GB 1487676	
	GB 1487677	IT 1047553	IT 1047555	
	JP 51057996	JP 51058295	JP 59021835	
	JP 60015338	US 4029120		
<hr/>				
US 4889115				
<hr/>				
US 4834086	EP 276676			

END OF ANNEX