

March 16, 1937.

T. L. RUSH

2,074,094

CAN OPENER

Filed July 15, 1936

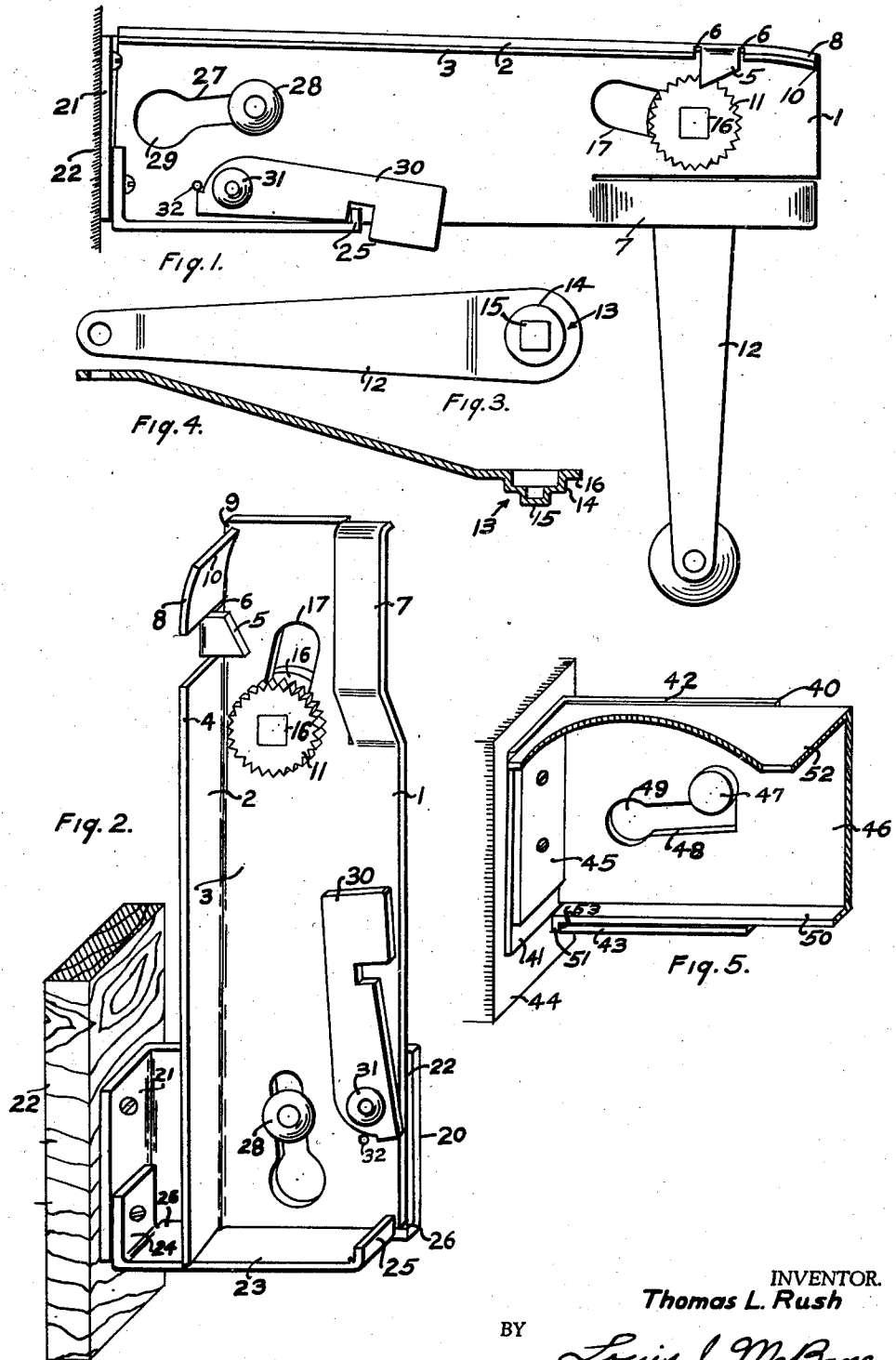

INVENTOR.

Thomas L. Rush

BY

Louis J. McBane.
ATTORNEY.

UNITED STATES PATENT OFFICE

2,074,094

CAN OPENER

Thomas L. Rush, Cleveland, Ohio

Application July 15, 1936, Serial No. 90,722

8 Claims. (Cl. 30--3)

This invention relates to a can opener.

It is an object of this invention to provide a novel can opener, improved in the structure and mode of operation of can opening mechanism proper and improved in the structure and operation of its mounting facilities.

It is an object of this invention to provide a novel can opener characterized by the simplicity and ruggedness of its structure and by the economy of its manufacture. It is an object of this invention to provide a can opener adapted to be mounted upon a suitable support and which may be arranged in operative position, moved to an out-of-the-way non-operative position, or which may be dismantled for cleaning or other purposes, all with great facility and without the exercise of skill or the use of tools. It is an object of this invention to provide a novel can opener which is substantially automatic in its action of engaging, opening, and disengaging a can. It is an object of this invention to provide a can opener having means for adapting the can opener to cans of variously sized beads and to accommodate variations in the dimensions of the bead of any particular can.

Other objectives and advantages in the present invention appear in the following detailed description, taken in connection with the accompanying drawing in which:

Figure 1 is a view, in side elevation, of a device of this invention.

Figure 2 is a view, in perspective, of the device shown in Figure 1, arranged in a different position.

Figures 3 and 4 are, respectively, a top plan view and a longitudinal cross-sectional view, of the handle for the can opener of Figure 1.

Figure 5 is a view, in perspective, of a modified form of mounting structure for the can opener.

In order to obtain economy of manufacture, a minimum number of parts, each made with a minimum number of inexpensive manufacturing operations, and a minimum of assembly operations of simple and inexpensive kind, are objectives to be taken into account in the design of a can opener. From the standpoint of use, durability and ruggedness, simplicity and ease of operation, adaptability to cans of various sizes, accessibility in use and ease of cleaning, all are objectives.

Ruggedness and economy of manufacture both are afforded by the use of a metal plate 1, shaped to provide many of the operating elements of the can opener as well as to constitute the support for the can opener. The plate 1 has the forward-

ly extending flange 2, formed by a simple bending operation. Flange 2 is at an angle relative to the back 3, of plate 1, less than 90°, so that flange 2 slants downwardly from the back 3 of the can opener, as arranged in the position illustrated in Figure 1. This insures that the forward edge 4 of flange 2 will engage the top of the can bead. This arrangement affords a certain line of contact between the flange 2 and the can bead, and that line of contact is at a position relative to the other can engaging and supporting parts where it affords a maximum of support for steadying the can while being opened. The edge 4 engages the top of the can bead at points on opposite sides of the blade.

In the interest of simplicity and ruggedness of structure as well as economy of manufacture, the blade 5 for shearing open the can is formed by making incisions 6 in the flange 2 and turning down the free end of the strip between the incisions. This structure insures a permanent position for blade 5 and a maximum of rigidity for the blade during operation.

Various cans have differently sized beads, and the bead of a can frequently varies somewhat, both in thickness and in height. Where the blade is rigidly fixed, as in this invention, it is desirable to provide can engaging and supporting structure, for maintaining the can in proper position relative to the blade when the can is being opened, which permits such movement of the can as is necessary to accommodate variations in size of bead, and which is adapted for use with cans having differently sized beads. To that end, a tongue 7 is struck up from the back 3 of plate 1. The tongue 7 provides a surface for engaging the side of the can, when the can is being opened, to support the can laterally, the lateral movement of the can being limited by engagement of the top of the bead with the edge 4 of flange 2. The tongue 7 is resilient and serves as a spring to maintain the can in position, with the bead of the can in engagement with edge 4, and the resiliency of tongue 7 permits the can to shift its position laterally as determined by variations in size of the bead. The resiliency of tongue 7 also accommodates cans having beads of different sizes. A leaf spring, or other resilient supporting means, may be attached to the plate 1, in lieu of the tongue 7, if desired.

To afford additional freedom of movement of the can, for variations in size of the bead, the flange 2 has a stub 8 which is stripped away from the plate 1, as indicated at 9, so that the end 10 of stub 8 may flex slightly. Variations in

bead size of a particular can and variations of bead size from can to can are accommodated by the resilient engagement of stub 8 with the top of the can bead.

5 The resilient structure described above also adapts the opener for use with cans of various sizes, both cylindrical and square, the variations in curvature from can to can, and in a square can, are accommodated by the resiliency of that structure without loss of the support afforded.

10 A traction wheel 11, is provided for engaging the underside of the can bead, and for turning the can relative to the blade 5 during opening movement of the can. The traction wheel 11 is carried on handle 12. The handle 12, and the connections between the traction wheel and the handle may vary, a desirable structure being illustrated, in detail, in Figures 3 and 4. As shown in Figures 3 and 4, the handle 12 is provided with a pressed portion 13, consisting of a circular shoulder 14 and with a square projection 15. The circular shoulder 14 affords bearing support for the handle 12 and the traction wheel 11, the square projection 15 engaging in an aperture 16, through the center of the traction wheel 11. The traction wheel 11, may have a press fit on the square projection 15, or the projection 15 may be peined over after being thrust through the aperture 16, or both. Any other suitable manner of mounting the wheel 11 on the projection 15 may be practised. The handle and the traction wheel structure is a very simple and inexpensive one and the bearing surfaces, at the periphery of the cylindrical shoulder 14, and between the face of wheel 11 and the surface 16 of handle 12, arranged in opposite sides of plate 1, afford adequate support for the wheel 11 in use.

The wheel and handle ensemble are mounted for rotation on plate 1 in a position where the wheel may engage the underside of a can bead when the blade 5 is in can opening engagement with the top of the can, the can being supported by engagement with tongue 7, edge 4, and end 10 of stub 8. In order to permit free and easy insertion of a can into can-opening position, a slot 17 is provided in the plate 1, the wheel and handle ensemble being mounted for rotatable and sliding movement in the slot. By moving the traction wheel 11 to the left, from the position shown in Figure 1, a can easily may be arranged in position to be opened. When the can is in position, with the tip of blade 5 touching the can top, adjacent to and within the bead, the handle 12 is manipulated to move the traction wheel to the right, thus bringing the traction wheel into contact with the underside of the can bead. Rotation of the handle 12 in a counter clockwise direction, as viewed in Figure 1, forces the traction wheel 11 to the right to the limit of movement permitted by slot 17 and forces the can upwardly and drives the point of the blade 5 through the can top. Continued rotation of handle 12, in counter clockwise direction, causes the can to turn and the blade to cut the top out of the can. The can is supported in can-opening position, without external assistance, by the engagement of the traction wheel 11 with the underside of the can bead and the engagement of the blade 5 with the can top at the inside face of the can bead, and by engagement of the can with the tongue 7, the flange 2, and the stub 8. These several points of engagement between the can opening structure and the can, not only support the can, but maintain it in

proper position for cutting out the can top as the can is turned by rotation of the traction wheel.

Upon rotating the handle 12 in a counter clockwise direction, when the handle 12 is being turned through the arc from the up position to the down position of the handle 12, there is a thrust upon the wheel and handle ensemble tending to move the ensemble to the left, as viewed in Figure 1, along slot 17. To prevent disengagement of wheel 11 with the can bead during that arc of movement of the handle, the slot 17 is arranged at an angle extending upwardly to the left, as viewed in Figure 1. Such a thrust, tending to move the wheel and handle ensemble to the left, while the wheel 11 is engaged with the bead, tends to move the traction wheel 11 upwardly along the slot 17. The upward movement of the traction wheel 11 forces it into tighter engagement with the can bead and limits such movement, to the left, of the traction wheel 11, to a very small amount and prevents disengagement of the traction wheel from the can bead.

When the can has been opened, the handle 12 is turned in a clockwise direction which rolls the traction wheel 11 from beneath the can bead, the can being thrust to the right, as viewed in Figure 1, so that the traction wheel 11 may escape from beneath the can bead even though the angle of slot 17 may cause the traction wheel to raise at that time. At such time, the blade 5 is riding in the slot cut in the can top and offers little or no resistance to an upward movement of the can bead as the wheel 11 moves from beneath the can bead. The disengaged wheel 11 is moved clear of the can and the can removed from the opener.

The slot 17 is straight, it may be curved, or other structure may be substituted for the slot. The traction wheel may be supported for rotation and shifting or lateral movement by a link system or by a pivoted arm, within the purview of this invention. The path of lateral displacement of the traction wheel may be varied as desired so long as it is in an oblique direction, upwardly as in Figure 1, relative to the shortest distance from the blade point to the wheel axis, when the latter is in can opening position, at least in proximity to can opening position of the wheel.

It will be apparent from the foregoing description and the drawing that a simple, rugged, reliable, and inexpensive construction of can opener has been afforded. The flange 2 provides rigidity to the plate 1, and at the same time, affords supporting engagement for the can bead. The simply made tongue 7 affords the requisite lateral support for the can. The blade 5 is simply made and is indestructible under ordinary conditions of use. The wheel and handle ensemble may be made inexpensively and the manner in which that ensemble is mounted on plate 1 affords a substantially automatic operation of the can opener, is adequate to withstand the strains imposed upon the ensemble, and involves a minimum of inexpensive assembly operations. The plate 1 may be provided with a foot to be mounted fixedly upon a suitable supporting wall, if desired.

To satisfy the requirements for ease in cleaning, for accessibility, and for disposal of when not in use, the mounting structure, illustrated in the drawing, is provided. A metal stamping 20 is formed with end plate 21 adapted to be secured to a supporting wall 22 by screws or in any other

suitable manner. The stamping 20 has face plate 22 adapted to project outwardly, in a substantially vertical plane, from the supporting wall. Base plate 23 is bent up from face plate 22 and adapted to extend in a substantially horizontal plane from the supporting wall. The base plate 22 has lug 24 turned up from one end thereof. Lug 24 is juxtaposed to the end plate 21 and a fastening screw may pass through both the lug 24 and the end plate 21. At the other end of base plate 23, an upturned portion 25 is provided, formed by a bending operation. The lug 24 and the upturned portion 25 are spaced from the face plate 22, by a distance approximating the thickness of plate 1. This affords a narrow ledge 26 along which the edge of plate 1 may be arranged with the margin of plate 1 extending between the side of lug 24 and upturned portion 25 and the face plate 22.

Plate 21 is provided with a slot 27 through which a rivet 28 extends, the rivet 28 being secured in the face plate 22. The plate 1 is held between the head of the rivet 28 and face plate 22. The slot 27 is provided with an enlarged opening 29 which may be slipped over the head of rivet 28 to mount or dismount plate 1 from the stamping 20.

As shown in Figure 1, the plate 1 is arranged in operating position on the stamping 20 with the rivet 28 at the end of slot 27. In that position, engagement between the rivet 28 and slot 27 prevents movement of plate 1 upwardly. Movement of plate 1 downwardly is obstructed by engagement of the bottom edge of plate 1 with face plate 23 of the stamping 20. Movement of plate 1 to the left is prevented by engagement of the end of the plate with end plate 21. Movement of plate 1 to the right is prevented by engagement of catch 30 with the upturned portion 25 of stamping 20. The catch 30 is pivoted on the plate 1 by a rivet or pin 31. A stop 32 is provided to limit the throw of catch 30 about pivot 31. Thus the plate 1 is held against any movement in a vertical plane parallel with face plate 22 of stamping 20. Engagement of plate 1 with the head of rivet 28 and with face plate 22, together with engagement of margins of plate 1 between upturned portion 25 and face plate 22 and between lug 24 and face plate 22, in the position illustrated in Figure 1, holds the plate secure in a vertical plane, against the face plate 22. Thus the rigid and secure mounting for the can opener is afforded.

The can opener easily may be detached from its mounting simply by moving the catch 30 out of engagement with upturned portion 25 when the plate 21 may be moved to the right, as illustrated in Figure 1, the slot 27 being at an angle so that, as the plate 1 moves to the right, rivet 28 lifts the bottom edge of plate 1 clear of base plate 23. When the plate 1 has been moved as far to the right as slot 27 permits, the plate 1 may be turned to a right angle and set in an upright position, such as illustrated in Figure 2, where it will be out of the way and yet in a convenient position for further use. When the plate 1 is arranged in an upright position, it rests upon the base plate 23, as illustrated in Figure 2, the head of rivet 28 supporting the plate 1 in place against face plate 22 and the corner of plate 1 being arranged between the upturned portion 25 and face plate 22. At any time, the plate 1 may be moved so that the head of rivet 28 is in register with the enlarged opening 29 of slot 27 and the plate 21 may then be removed from

the stamping 20 to be put away or to be washed, as desired.

The above described structure for mounting the can opener is simple and inexpensive to make. Stamping 20 is of inexpensive material and made by a few simple stamping operations. The catch 30 and the slot 27 provided on plate 1 both are made by inexpensive manufacturing operations. The catch 30 is mounted upon plate 1 by a rivet, or the like, and the plate 1 is mounted upon stamping 20 by another rivet, both of which are inexpensive operations. The resulting structure is rugged, durable, and exceedingly simple to operate. To arrange the can opener in operative position, from the position shown in Figure 2, it is necessary only to lift the plate 1 upwardly, turn it to a horizontal position, and thrust it back into position, the catch 30 falling into place by its own weight. The can opener is disengaged simply by reversing those operations. No skill or tools are required for mounting or dismounting the can opener.

A modified structure of mounting facility is illustrated in Figure 5. A bracket 40 has an end plate 41 turned up from the face plate 42. A base plate 43 is turned up from another side of the face plate 42. The bracket 40 is mounted to a supporting wall 44 by screws passing through the end plate 41. A flat plate 45 is juxtaposed to the end plate 41 and held in place by the fastening screws. The edge of flat plate 45 next to face plate 42 is spaced from the face plate 42 a distance such as snugly to receive a margin of the plate 46 of the can opener. A rivet 47 is secured to the face plate 42.

Plate 46 is provided with a slot 48, adapted to fit beneath the head of rivet 47. The slot 48 has an enlarged opening 49 through which the head of the rivet 47 may pass. The plate 46 has a lateral margin 50 struck up from the plate. The lateral margin 50 has a lug 51 turned down therefrom. The plate 46 has a forwardly extending flange 52 which imparts rigidity to the plate and may afford certain functions in connection with the can opening mechanism proper.

In order to secure the plate 46 rigidly in place upon the bracket 40, the plate 46 is arranged in the position illustrated in Figure 5, with the end margin of plate 46 arranged between the edge of flat plate 45 and the face plate 42. The plate 46 is arranged so as to lodge the lug 51 behind the edge 53 of base plate 43. The configuration of slot 48 is such as to permit the above described arrangement. In that position, movement to the left of plate 46 is prevented by engagement by the end of the plate with the end plate 41. Movement to the right of plate 46 is prevented by engagement of lug 51 with edge 53 of face plate 43. Movement downwardly of plate 46 is prevented by engagement of lateral margin 50 with base plate 43. Upward movement of plate 46 may be effected if that movement is in a straight line upward. However, the normal operation of the can opener, which is located at the end of plate 46 distant from the bracket 40, imposes a couple on the bracket 40 and does not impose any force directed vertically, only, on the plate 46. Such a couple imposed upon the mounting structure by operation of the can opener is resisted by engagement of lug 51 with edge 53, by engagement of end of plate 46 with end plate 41, and by engagement of rivet 47 with the slot 48. The mounting structure holds the plate 46 securely in place during all normal operations of the can opener.

When it is desired to disengage plate 46, it is necessary only, by a firm grasp on the plate 46, to impose a directly vertical force upon the plate 46 which lifts the plate 46 so as to free the lug 51 from engagement with edge 53. Then the plate 46 may be moved to the right, due to the configuration of slot 46. Subsequently, the plate 46 may be turned to an upstanding position and left in that position with the end of plate 46 resting upon base plate 43, the position of the parts being similar to that illustrated in Figure 2. Or, the plate 46 may be removed from bracket 40 by slipping the enlarged opening 49 over the head of rivet 47. The dismounted can opener may be put away or cleaned and returned to position, as desired. The lug 51 affords a function similar to that of catch 30 of Figures 1 and 2. The structure of the can opener proper may be like that of Figures 1 and 2 or may be a variation thereof.

The invention has been described in detail by way of illustration. It is not intended so to limit the invention inasmuch as variations in the details thereof may be made by one skilled in the art without departing from the scope of the following claims.

What I claim as my invention is as follows:

1. A can opener having a fixed blade, a traction wheel adapted to engage the bead of a can arranged in cutting engagement with the blade, means supporting the wheel for rotation and for movement lateral to the axis of rotation in a direction oblique to the shortest distance between the blade point and the wheel axis in can-opening position, the path of movement of the traction wheel between can opening position and can disengaging position being such that the side of the traction wheel engages and moves relative to the side of the can bead with the blade in can engaging position, the periphery of the traction wheel engaging the underside of the can bead when in can opening position, means for rotating the traction wheel.

2. A can opener having a fixed blade, a traction wheel adapted to engage the bead of a can arranged in cutting engagement with the blade, a plate supporting the blade, a slot in the plate, a traction wheel mounted for rotation and for lateral movement in the slot, said slot extending obliquely from the can-opening position of the wheel so that the path of movement of the traction wheel between can opening position and can disengaging position is such that the side of the traction wheel engages and moves relative to the side of the can bead with the blade in can engaging position, the periphery of the traction wheel engaging the underside of the can bead when in can opening position.

3. A can opener comprising a plate having a portion adapted to be arranged in a substantially vertical plane when in can opening position, the top margin of the plate extending laterally from the vertical portion, the outer edge of the lateral margin being arranged to engage the top of a can bead in can opening position, the end of the lateral margin being free from the vertical portion and being arranged to engage the top of the can bead resiliently, a blade integral with the lateral margin and arranged to extend downwardly therefrom in spaced relation to the vertical portion, a slot in the vertical portion having one end in proximity to the blade, a traction wheel and crank mounted for rotation and lateral movement in the slot, a leaf spring on the vertical portion and extending in a substantially horizon-

tal direction beneath the can opening position of the traction wheel, said spring being spaced from the vertical portion a distance such as resiliently to engage the side of a can arranged in opening position.

4. A can opener comprising a plate having a portion adapted to be arranged in a substantially vertical plane when in can opening position, the top margin of the plate extending laterally from the vertical portion, the outer edge of the lateral margin being arranged to engage the top of a can bead in can opening position, the end of the lateral margin being free from the vertical portion and being arranged to engage the top of the can bead resiliently, a blade integral with the lateral margin and arranged to extend downwardly therefrom in spaced relation to the vertical portion, a slot in the vertical portion having one end in proximity to the blade, a traction wheel and crank mounted for rotation and lateral movement in the slot, the path of movement of the traction wheel along the slot being obliquely downward relative to the blade from can dis-engaged position to can opening position, a leaf spring integral with the vertical portion and extending in a substantially horizontal direction beneath the can opening position of the traction wheel, said spring being spaced from the vertical portion a distance such as resiliently to engage the side of a can arranged in opening position.

5. A can opener having a plate constructed and arranged to support a can being opened, a blade and a traction wheel operatively mounted on the plate, a bracket adapted to be secured to a support; said bracket having substantially vertical end plate, a substantially vertical face plate extending away from the end plate, and a substantially horizontal base plate extending from the end plate along the bottom of the face plate; said opener plate being constructed for arrangement on the bracket with the bottom edge of the opener plate resting on the base plate, with the end of the opener plate abutting the end plate, and with the adjacent surfaces of the opener plate and the face plate juxtaposed; said base plate having upwardly projecting parts arranged to engage that face of the opener plate distant from the face plate, a pin and slot connection between the opener plate and the face plate, said pin having a head to maintain the opener plate and the face plate juxtaposed, said slot being arranged to permit sliding movement of the opener plate relative to the face plate in a direction away from the end plate and the base plate, a latch mounted on the opener plate for engaging with the base plate to restrain such sliding movement when the opener plate is engaged with the bracket in can opening position.

6. A can opener having a plate constructed and arranged to support a can being opened, a blade and traction wheel operatively mounted on the plate, a bracket adapted to be attached to a support; said bracket having a side wall, an end wall, and a bottom wall in three planes, each substantially perpendicular to the other two planes; said plate being mountable on the bracket with the side of the plate juxtaposed to said side wall, there being means on the bracket spaced from the side wall and arranged to engage the side of the plate distant from the side wall, said means and the side wall constituting a slot-like structure such that the plate may be inserted and withdrawn therefrom by sliding movement of the plate relative to the side wall, the end and bottom edges of the plate being engaged with the end wall and

bottom wall of the bracket when the plate is inserted into the slot-like structure, a pin and slot connection between the plate and side wall arranged to guide the plate during insertion and to maintain the bottom edge of the plate engaged with the bottom wall when the plate is in inserted position, dis-engageable means for locking the plate against sliding movement when in inserted position.

5
10
15
20
25
7. A can opener having a plate constructed and arranged to support a can being opened, a blade and traction wheel operatively mounted on the plate, a bracket adapted to be attached to a support; said bracket having a side wall, an end wall, and a bottom wall in three planes, each substantially perpendicular to the other two planes; said plate being mountable on the bracket with the side of the plate juxtaposed to said side wall, there being means on the bracket spaced from the side wall and arranged to engage the side of the plate distant from the side wall, said means and the side wall constituting a slot-like structure such that the plate may be inserted and withdrawn therefrom by sliding movement of the plate relative to the side wall, the end and bottom edges of the plate being engaged with the end wall and bottom wall of the bracket when the

plate is inserted into the slot-like structure, a pin and slot connection between the plate and side wall arranged to guide the plate during insertion and to maintain the bottom edge of the plate engaged with the bottom wall when the plate is in inserted position, dis-engageable means for locking the plate against sliding movement when in inserted position, said pin having a head for maintaining the plate in juxtaposition to the side wall, said slot being constructed and arranged to permit rearrangement of the plate relative to the bracket in an out-of-the-way position and to permit detachment of the plate from the bracket.

5
10
15
20
25
8. In combination with a can opener, a traction wheel and crank ensemble comprising a handle having a pressed portion extending laterally therefrom, said pressed portion having a cylindrical part and a projection extending beyond the cylindrical part, said traction wheel having an aperture, the handle and traction wheel being fixedly connected at the projection and aperture with the cylindrical part rotatably mounted on the can opener, the adjacent faces of the traction wheel and of the handle being arranged on opposite sides of a supporting plate of the can opener.

THOMAS L. RUSH.