

No. 770,577.

PATENTED SEPT. 20, 1904.

S. HATASHITA.
CAR ROOF.

APPLICATION FILED JUNE 25, 1902.

NO MODEL.

2 SHEETS—SHEET 1.

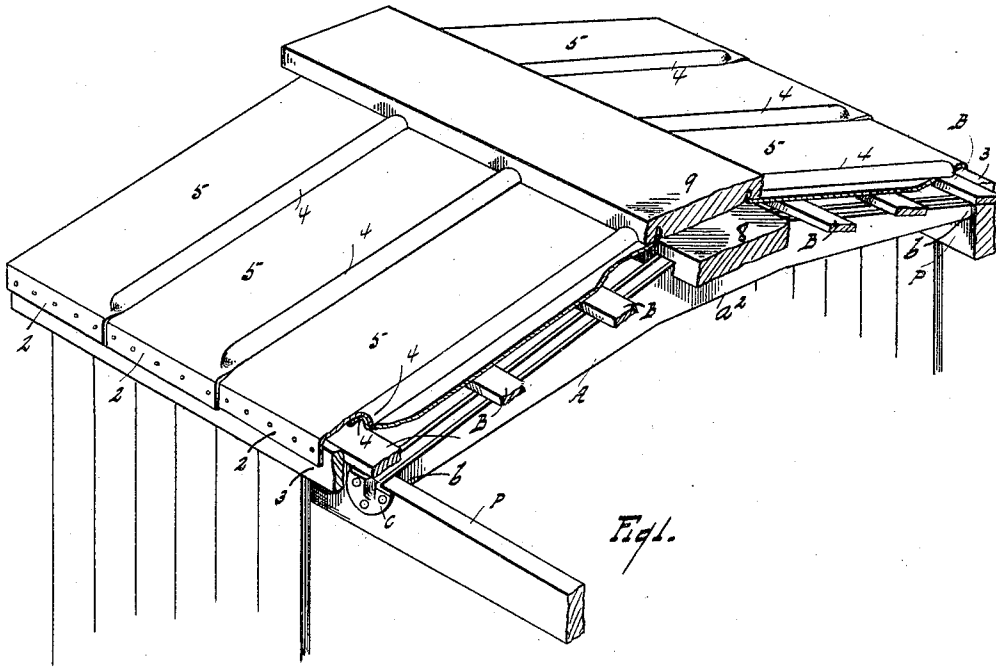

Fig. 1.

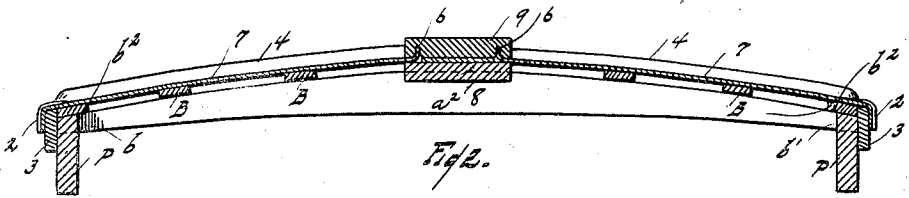

Fig. 2.

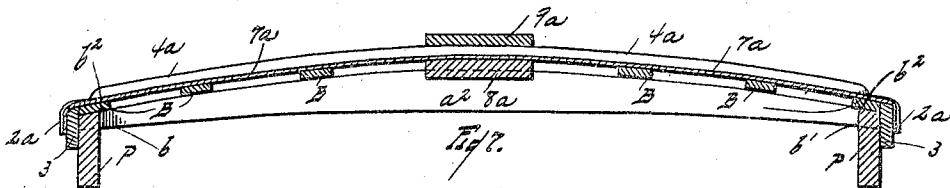

Fig. 3.

WITNESSES

Lotta Lee Hayton.
J. Y. Massey.

INVENTOR

Seyo Hatashita.

By

Parker & Burton.
Attorneys.

No. 770,577.

PATENTED SEPT. 20, 1904.

S. HATASHITA.
CAR ROOF.

APPLICATION FILED JUNE 25, 1902.

NO MODEL.

2 SHEETS—SHEET 2.

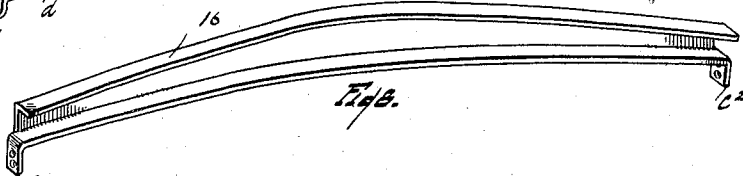
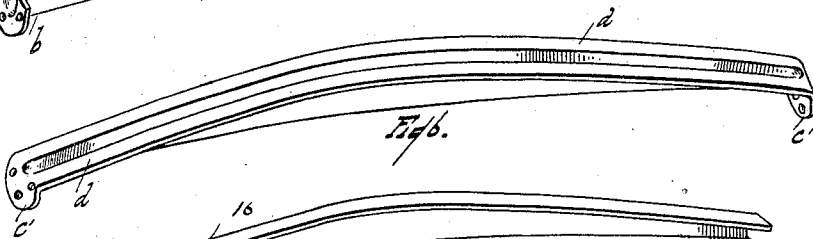
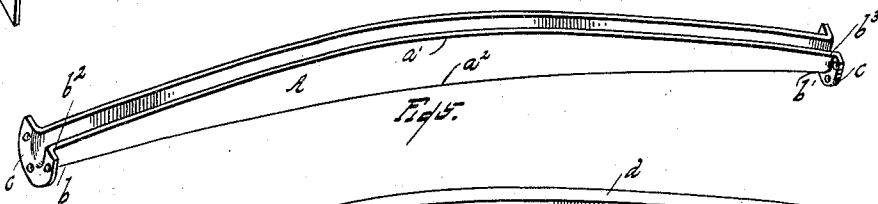
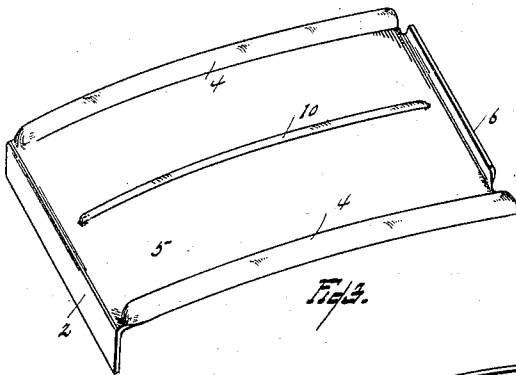
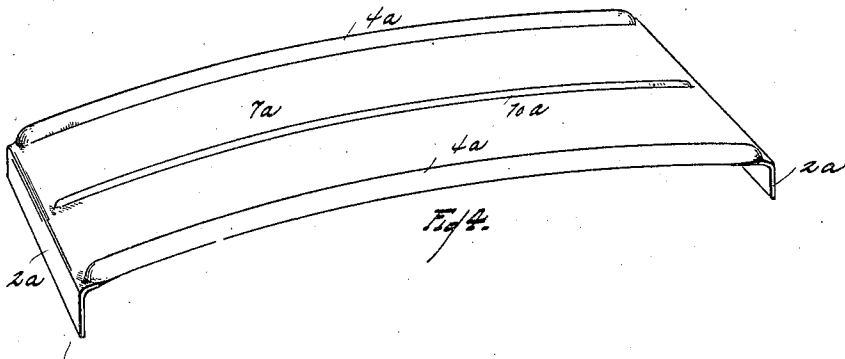

WITNESSES
Lotta Lee Hayton.
J. F. Massey

INVENTOR
Sezo Hatashita.
By Parker & Burton.
Attorneys.

UNITED STATES PATENT OFFICE.

SEZO HATASHITA, OF DETROIT, MICHIGAN.

CAR-ROOF.

SPECIFICATION forming part of Letters Patent No. 770,577, dated September 20, 1904.

Application filed June 25, 1902. Serial No. 113,066. (No model.)

To all whom it may concern:

Be it known that I, SEZO HATASHITA, a subject of the Emperor of Japan, residing at Detroit, county of Wayne, State of Michigan, have invented a certain new and useful Improvement in Car-Roofs; and I declare the following to be a full, clear, and exact description of the invention, such as will enable others skilled in the art to which it pertains to make and use the same, reference being had to the accompanying drawings, which form a part of this specification.

This invention relates to car-roofs, and has for its object an improved roof applicable to cars and similar structures.

In the drawings, Figure 1 is a perspective showing a portion of a car-roof, part of the roof being broken away to show one of the supporting-carlines. Fig. 2 is a cross-section of the roof. Fig. 3 is a perspective of the metal sheet used as a covering for the roof. Fig. 4 is a perspective of a sheet arranged to stretch from side to side over the roof. Fig. 5 is a perspective of a metal carline. Fig. 6 is a perspective of a metal carline differing slightly in shape from the carline of Fig. 5. Fig. 7 is a cross-section of the roof using the long roofing-sheet of Fig. 4. Fig. 8 is a perspective of a carline having the channel-opening at one side.

The carline which supports the roof is made of bent metal semitubular in form, curved, and provided with flanges at its ends and open on the upper side. This carline A is of metal bent into U form and curved or cambered between its ends, so that in position it arches at the middle point. The middle vertical line is longer from the point a' to the point a'' than is the vertical thickness of the carline at either end, so that while the line from b a'' b' is arched the line from b'' through a' to b'' is arched to a greater extent or with a shorter radius. The upper side of the carline is open, and it is preferably filled with a fillet of wood or other material suitable to hold nails. Each end of the carline is provided with a flange c , by means of which the ends of the carline engage outside the plate P of the car. In the form shown in Fig. 6 the upper or free edges of the carline d are flanged outward, and the strips B

may be bolted or nailed to the flanges or to a wood fillet placed in the opening. The carline of Fig. 6 is provided with flanges c' , similar to those in the carline of Fig. 5. The roofing material placed over the strips B is of sheet metal curved, provided with a flange 2 at the outer end, which drops over the plate B and over a facing-board 3, to which it is nailed or otherwise secured. On each edge (except the plate at the extreme end of the car) it is provided with a ribbed part 4 that is convex upward, and the rib vanishes on the main web 5 of the plate near the turn of the flange 2. On the inner end the plate is provided with an upturned flange 6, and the rib 4 extends to and terminates in a line which is in continuation of the plane of the upturned flange 6. The rib 4 of one plate is hollow on its under side and is arranged to nest over the corresponding rib on the opposite side of another plate, so that when the two plates are placed contiguous in making the roof of the car the rib of one plate engages over the underlying rib portion of the contiguous plate, making a strong water-tight seam, and the seam may be packed, if desired, with any suitable packing when the roof is laid. The upper end of the plates rest on a broad ridge-plank 8, and a plank 9, provided with grooves on the under side and at either edge, engages over the ridge-plank 8 with the upturned flanges 6 engaging in the grooves of the plank 9. The plank 9 firmly secures the ends of the plates with a fastening that is water-tight, and the planking constitutes a suitable running-board along the car. The plates are preferably provided with an additional rib 10, running parallel with the sides, which is convex upward and which vanishes at either end into the web of the plate.

A modified form of plate (shown in Fig. 4) is made long enough to extend from side to side over the car, and this is provided with the side ribs 4^a and with the strengthening-rib 10^a , which vanish at each end into the web 7^a . The long plate is provided with the end flanges 2^a , that engage over the plate P and the facing-board 3; but no provision is made for a middle flange, as none is used. The middle part of the plate is supported by a ridge-plank 8^a , and the running-board 9^a is

laid over the top of it, provided with suitable dross gains or grooves for the ribs 4^a of the metal.

5 8. A modified form of carline is shown in Fig. 8. The channel has its opening at one side, and the upper flange 16 curves under the roof and has the strips B secured to it. The ends c² are flanged to enable them to be secured to the facing-plate.

10 What I claim is—

1. In a car-roof, the combination of a sheet of metal provided with ribs extending along the edges convexed upward and concaved downward so that ribs on adjacent plates may
15 be placed one over the other and one within the other, said plates being provided with flanges at the ends, one of which is arranged to turn downward and engage over the edge of the roof, and the other of which is ar-
20 ranged to turn upward to engage in a groove extending upwardly from the under side of the running-board, and a running-board having a longitudinal groove extending upward from its under side and laterally-extending grooves
25 adapted to fit over said ribs, substantially as described.

2. The combination of a ridge-plank, a roofing-sheet comprising a sheet of metal provided

with ribs extending along the edges convexed upward and concaved downward so that ribs
30 on adjacent plates may be placed one over the other and one within the other, said plates being provided with flanges at its ends, one of which is arranged to turn downward and en-
35 gage over the edge of the roof and the other of which is arranged to turn upward to engage in a groove extending upwardly from the under side of the running-board, and a running-board having a longitudinal groove
40 extending upward from its under side and laterally-extending grooves adapted to fit over said ribs, substantially as and for the purpose described.

3. The combination of the ridge-board, a roofing-plate having its end resting on said
45 ridge-board and its edge at that end turned upward, and a running-board having a groove extending upward from its under surface adapted to fit over the upturned edge of the
50 roofing-plate.

In testimony whereof I sign this specification in the presence of two witnesses.

SEZO HATASHITA.

Witnesses:

MAY E. KOTT,

CHARLES F. BURTON.