

(No Model.)

2 Sheets—Sheet 1.

D. M. PROSSER.
WOOD SAWING MACHINE.

No. 497,209.

Patented May 9, 1893.

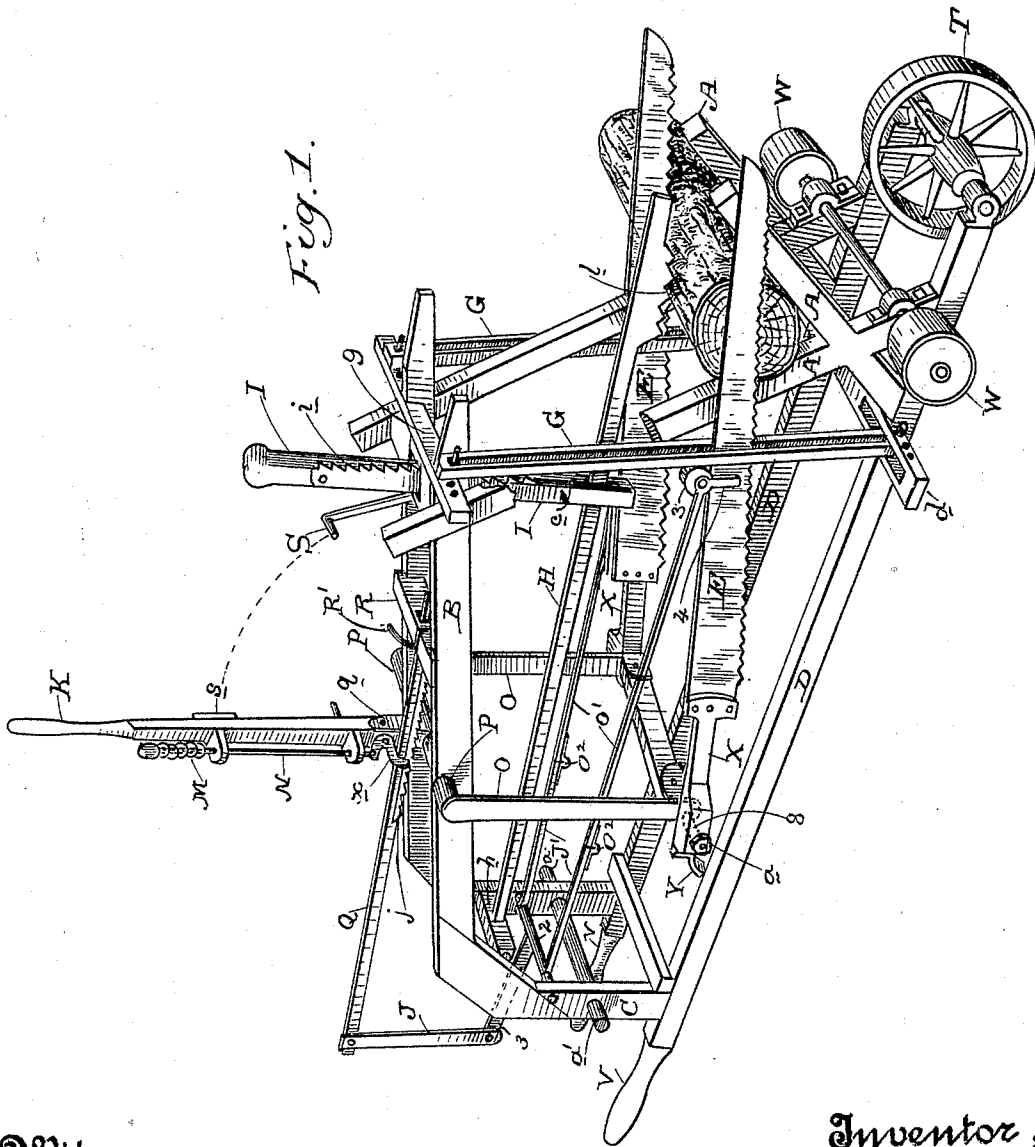

Witnesses,
J. H. Anouse
J. A. Bayless

Inventor,
David M. Prosser
By Dewey & Co.
attys

D. M. PROSSER.
WOOD SAWING MACHINE.

No. 497,209.

Patented May 9, 1893.

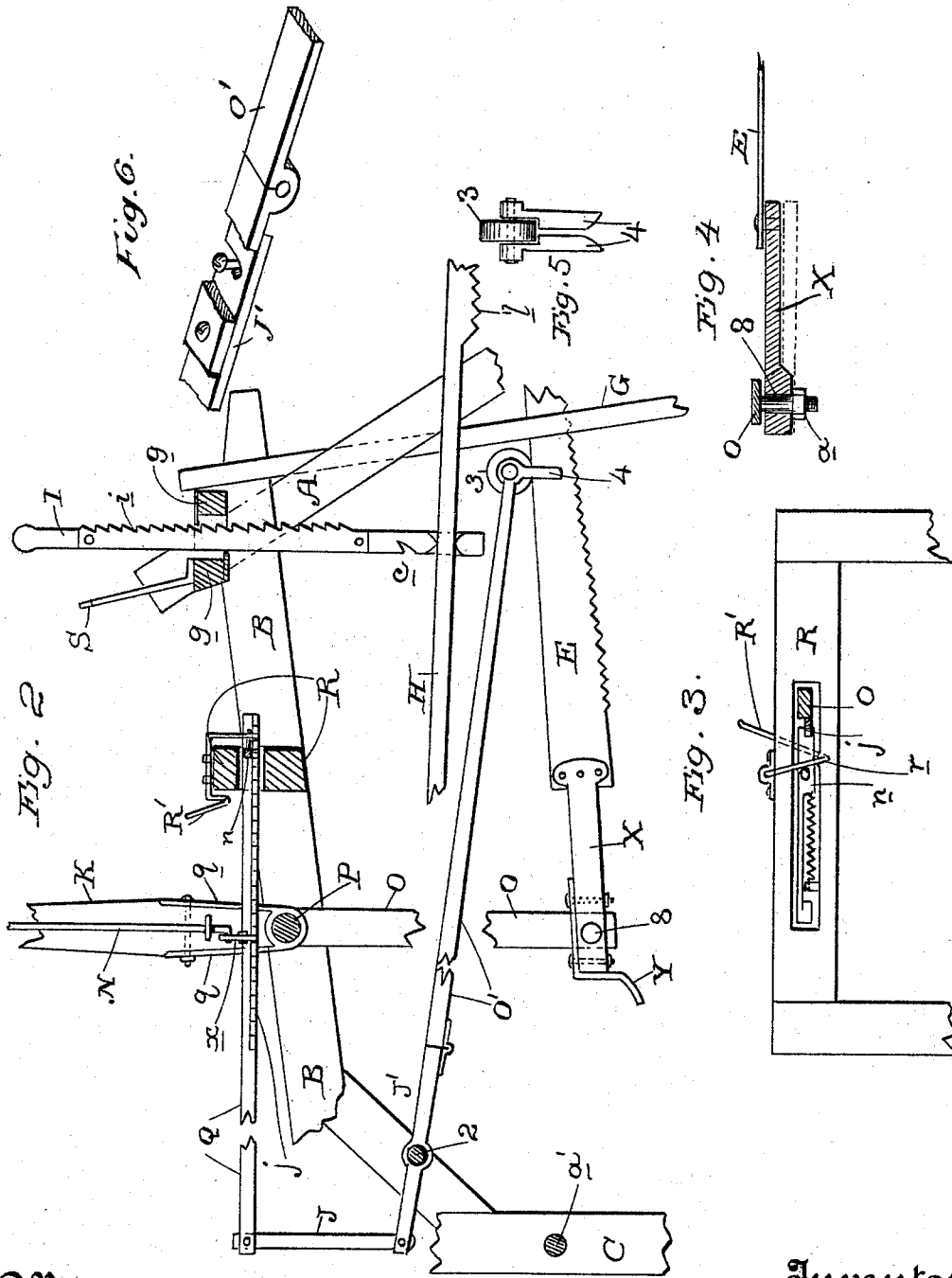

Witnesses,
J. A. Prosser
J. A. Boyless

Inventor,
David M. Prosser
By Dewey & Co.
attys

UNITED STATES PATENT OFFICE.

DAVID MANSFIELD PROSSER, OF RENO, NEVADA.

WOOD-SAWING MACHINE.

SPECIFICATION forming part of Letters Patent No. 497,209, dated May 9, 1893.

Application filed May 27, 1892. Serial No. 434,671. (No model.)

To all whom it may concern:

Be it known that I, DAVID MANSFIELD PROSSER, a citizen of the United States, residing at Reno, Washoe county, State of Nevada, have invented an Improvement in Wood-Sawing Machines; and I hereby declare the following to be a full, clear, and exact description of the same.

My invention relates to a wood sawing apparatus.

It consists in the combination of one or more saws with adjusting and operating mechanism, and a saw-buck upon which the wood is placed, with means for retaining it in place while being sawed, and in certain details of construction which will be more fully explained by reference to the accompanying drawings, in which—

Figure 1 is a perspective view of my invention. Fig. 2 shows the working parts in detail. Fig. 3 shows the beam R and latching mechanism. Fig. 4 is a section of one of the saw handles—dotted line shows it reversed for making a longer cut. Fig. 5 is a front view of one of the pressing rolls and guide. Fig. 6, is a detail showing the connection of the arms J' with the spring arms O'.

The object of my present invention is to provide a simple sawing apparatus by which wood is rapidly cut into suitable lengths.

A is the saw-buck (as it is technically called) made of crossed timbers suitably connected together, the rear most timbers extending upwardly to a considerable height to serve for the attachment of timber B which extends rearwardly therefrom and has its rear end supported by the vertical timber C. The lower end of this timber, and the lower ends of the saw-buck frame are supported upon a horizontal frame-work D which forms the base of the whole apparatus. Near the front end of the frame D is journaled a wheel or wheels T for the purpose of transporting the machine from place to place. At the rear end are handles V by which the apparatus may be easily handled.

P is a horizontal shaft journaled across the frame B having upwardly projecting plates q between which the lower end of a handle K is securely bolted. From the outer ends of the shaft P arms O extend downwardly and have pins 8 projecting outwardly from each

with suitable nuts or keys a by which the saw handles may be secured upon these pins.

The saw handles are made two inches in thickness at the rear ends and one inch at the front ends, being beveled off from one side to give this reduced thickness. The two saws E are secured to the front ends of the handles and extend forward so as to cross the saw-buck frame and when the handle K is reciprocated, the arms O and the saws receive a corresponding motion so that when the stick of wood is laid upon the saw-buck and properly held in place the saws being reciprocated across it, will cut it into lengths.

The apparatus is designed to cut wood into twelve, fourteen, or sixteen inch lengths, and this is done as follows:—To cut sixteen inches attach the saws to the straight sides of the handles and place the handles upon the pins with the straight sides outward. To change to cut twelve inches, the handles are changed upon the pins to stand with the straight sides in the saws being attached to the straight sides. To cut fourteen inches the saws are changed upon the handles and are fixed to the beveled sides, and as these sides are fourteen inches apart the handles may be placed upon the pins with either side outward.

In order to hold the stick in place I have shown a bar H, the rear end of which is pivoted or fulcrumed upon a cross-bar or timber h at the rear of the frame-work, and the front end is provided with teeth l which rest upon the stick after it is placed upon the saw-buck. This is held firmly in place by means of a vertically sliding rack bar I having teeth i. This rack bar moves through a guide hole or slot in the cross bar g which extends across between the timbers B. The slotting through which the bar I passes, has a plate in front which the teeth of the rack I engage when the bar H has been pressed down, so that the teeth l press upon the stick to hold it in place. When it is desired to remove the stick and replace it with a new one, the rack of this bar I is detached from the holding plate which it engages in front and is lifted up until the notch c made in the rear of the bar, near the lower end, engages with a plate upon the rear of the slot in the bar g and this holds the bar I and the bar H up while the block is being replaced.

The saws are guided by vertical slotted guide bars G, through which they pass, the upper and lower ends of these guide bars being supported by the cross bar *g* and a bar *d* which extends across between the bottom timbers D. These vertical guide timbers are secured by pins or bolts and are movable laterally to correspond with the movement of the saws to cut different lengths.

When it is desired to raise the saw out of its position for the purpose of introducing or removing a stick, it is done by pressing the handle K forward. This causes the arms O, by which the saws are carried, to move rearwardly, and each of the saw handles X has a hook or projection Y at the rear end and behind the pin 8.

a' is a rod or bar extending across between the supporting timbers C at the rear with projecting ends, and when the saw handles are carried backward by the forward movement of the lever K, the projections Y engage with this cross-piece, which thus forms a fulcrum and a further movement forward of the handle, raises the saw up against the under part of the cross-bar *g*. The handle has a little projecting lug *s* upon one side, and when the handle is thrown forward it engages a corresponding catch S upon the rear of the cross-bar *g*, and this holds the saws up out of the way while the stick is being removed or replaced, after which the handle is disengaged from the catch and the saw allowed to drop into position upon the top of the stick.

In order to exert a sufficient pressure upon the saws to cause them to work properly, I have shown a spring arm O' having at the front end a roller 3 journaled between two guide forks 4 which extend down upon each side of the saw plate.

The upper part of the guide forks, between which the roller is journaled, has a wider space than the thickness of the saw so that the roller which fills this space projects on each side of the back of the saw and prevents the latter from slipping past it.

Pressure is brought upon the backs of the saws by means of a lever arm Q, the rear end of which is connected with the rear of the spring arm O' by a connecting rod J transversely journaled arms 2 and rearward extension 3, and the arms J' extending forward in line with the spring arms O' which are bolted to them as shown. The front bolt holes are slotted transversely to allow the front ends of the spring arms to be moved to one side or the other when the saws are set to cut different lengths.

N is a sliding bar moving upon the side of the handle K and having a spring M by which it is actuated. The lower end of the bar N is connected with a bell crank catch *z* which is adapted to engage with the teeth of a rack *j* upon the side of the sliding bar Q. When the rod N is pushed down until this engagement is made, the handle K is then pushed forward, thus moving the bar Q until suffi-

cient pressure is brought upon the spring arm O' through its connections J and J'.

When the bar Q is drawn forward, as described, it slides in a hole made in the cross-bar R, and the rack *j* upon it engages with a spring-actuated holding catch *n* in the bar R which thus keeps a constant tension and elastic pressure through the connecting arms J J' and their adjuncts and the spring arm O' upon the back of the saw. Whenever the saw has cut down into the stick so that this pressure is too much reduced, it is increased by again pressing the rod N downward to engage the pawl X and rack *j*, and thus when the handle K is moved forward, to again draw the latter forward to increase the pressure. This pressure may be increased regularly by moving the bar Q forward a single notch at each stroke of the saw, if desired.

When it is desired to disengage the rack from the holding catch *n* in bar R it is done by means of a small arm R' which is engaged by the handle K when the latter is pushed forward so as to engage the arm R' and cause it to turn in engage a pin upon the sliding catch *n* and thus force it back out of engagement with the rack *j*, which allows the bar Q to slide backward and relieve the spring arms O' which press upon the backs of the saws.

When the saws have cut through either end of the stick, the saw which first cuts through (as in case the stick is smaller at one end than the other), will drop upon a loosely journaled roller W mounted upon a shaft journaled to the saw buck, or the front braces thereof, and near the front end of the saw. This allows the saw which has finished its cut to reciprocate on the roller, the latter merely turning backward and forward until the other saw has cut through its portion and the work is complete, after which both saws may be raised as previously described, and the work will proceed.

The spring arms O' are hinged as shown at O² so that the front ends may be bent downward, but can only be bent up so far as to stand in a straight line with the rear portion. This allows the saws to accommodate themselves to sticks having a considerable difference in diameter.

Having thus described my invention, what I claim as new, and desire to secure by Letters Patent, is—

1. In a sawing machine, saws having the handles made of different thicknesses with offsets at the front end, means whereby the saws are secured to either side of the handles to adjust them toward and from each other, a frame-work having a rock shaft with arms extending downwardly, and connecting with the saw handles by means of journal pins, and a single lever arm bolted between clamping plates extending upwardly from the rocker shaft, and a saw-buck or support for wood to be cut, whereby the latter is supported transversely beneath the line of travel of the saws, substantially as herein described.

2. In a sawing machine, a saw-buck or support for wood to be cut, a frame having a rocker shaft with upwardly projecting handle, arms projecting downwardly from the ends, journal pins fixed to said arms, saws having handles with offsets to which the saws are removably attached whereby the saws may be adjusted toward and from each other, slotted guides G through which the front ends of the saws pass, having the upper and lower ends fixed and capable of adjustment to or from each other to correspond with the adjustment of the saws, substantially as herein described.

3. In a sawing machine, a saw-buck or support for the wood to be cut, the main frame having a rocker shaft with operating lever and arms to which the rear of the saw handles are adjustably connected, slotted guides between which the front ends of the saw blades move and by which they are kept in position, the holding bar H having a serrated plate at the front which rests upon the stick, and the vertically moving adjustable rack bar I through which the bar H passes and by which it is pressed down to hold the stick in position upon its support while being cut, substantially as herein described.

4. In a sawing machine, a support for the wood to be cut, saws reciprocating transversely thereto; rocker arms to which the handles of the saws are connected, and a lever by which the rocker arms and saws are moved, a bar H adapted to press upon the stick and hold it in place, a vertical rack bar I engaging the holding bar H, the transverse bar g through which the vertical rack bar moves having a plate at the front of the slot with which the teeth of the rack bar engage, and a separate plate at the rear with which a notch c in the lower end of the rack bar is engaged when the rack bar and the holding bar H are raised for the purpose of removing or replacing the stick, substantially as herein described.

5. In a sawing machine, a support for the wood to be cut, one or more saws reciprocating transversely across the wood, a rocker shaft, arms depending therefrom to which the handles of the saws are adjustably connected, a handle by which the rock shaft and saws are oscillated, vertically slotted guides for the front ends of the saws, and the movable holding device by which the stick is held in place, in combination with the elastic arms O' having the guides 4 fitting upon each side of the front end of the saw blade and the roller 3 journaled between said guides and resting upon the back of the saw upon which it exerts a pressure, substantially as herein described.

6. In a sawing machine, horizontally reciprocating saws with the actuating rocker arms, guides for the front ends of the saws and the spring arms pressing upon the backs of the saws, in combination with the levers J J' with the integral fulcrum shaft, the rear of the spring arm being attached to the end of the

lever J', a movable rack bar Q connected with the lever J, and a catch by which said bar is retained so as to cause the levers to exert a pressure upon the spring arm, substantially as herein described.

7. In a sawing machine, the horizontally reciprocating saws with the rocker arms to which the handles are connected, guides for the front ends, spring arms resting upon the backs of the saws, a rock shaft with levers rigidly fixed thereto, one of which is connected with the spring arms, and the other with a horizontal sliding rack bar Q, a spring catch by which the rack bar is retained in any desired position, a spring actuated sliding arm N movable upon the lever K which actuates the saws, a pawl X connected with the rod N and adapted to engage the rack upon the bar Q whereby when so engaged the forward movement of the lever K will carry the rack bar Q forward and place any degree of tension upon the spring arms which press upon the saws, substantially as herein described.

8. In a sawing machine, the horizontally reciprocating saws, a support for the wood to be cut, means for holding it in place, a rock shaft with arms to which the handles of the saws are connected so as to be reciprocated thereby, a handle projecting upwardly from the rock shaft through which power is applied to reciprocate the saws, a spring arm resting upon the back of each saw, a rock shaft with rigidly fixed levers, one of which is connected with the spring arm, and the other with the sliding rack bar Q, the pawl X, the sliding rod N connected therewith adapted to throw it into or out of engagement with the rack of the bar Q, and a yielding catch n by which the bar Q is retained in any position to which it may be moved by the movement of the lever K, in combination with the disengaging lever arm R' adapted to be engaged by the lever K when it is thrown forward for the purpose of disengaging the rack bar from the catch n and allowing it to move backward and relieve the pressure upon the spring arm, substantially as herein described.

9. In a sawing machine, the horizontally reciprocating saws, means whereby the saws are adjustable to increase or diminish the distance between them and thereby the length of the cut, rocker arms and handles by which the saws are reciprocated, spring arms O' having guide plates 4 4, and rollers 3 fitting the backs of the saws, and pressing thereon a rock shaft with the rigidly fixed arms J J', means whereby tension is applied through said arms to the spring arm O', a transverse slot made through the outer end of the arm J', and bolt-holes and bolts whereby the rear end of the spring arm is secured to the end of the arm J', and made adjustable from side to side to suit the movements of the saws for a longer or shorter cut, substantially as herein described.

10. In a sawing machine, the horizontally

reciprocating saws, a support for the wood to
be cut, across which the saws move, rocker
arms to which the handles of the saws are
adjustably journaled, a rock shaft to which
5 these arms are connected, and an actuating
lever projecting upwardly therefrom, bent
arms Y fixed to the rear ends of the handles
behind their journal pins, and fixed trans-
verse bar *a'* which is adapted to engage the
10 bent arms Y when the saws move rearwardly,
and to serve as a fulcrum about which the
saws are lifted by the forward movement of
the actuating lever arm K after the bent arms

engage the fulcrum bar, the catch *s* upon the
lever K and the latch S fixed to the main 15
frame or cross-bar thereof which is engaged
by the catch so as to hold the saw up, while
the stick is being placed upon its support or
removed therefrom, substantially as herein
described. 20

In witness whereof I have hereunto set my
hand.

DAVID MANSFIELD PROSSER.

Witnesses:

W. P. McLAUGHLIN,

CHAS. C. JONES.