

(19) World Intellectual Property Organization  
International Bureau



(43) International Publication Date  
1 March 2012 (01.03.2012)

(10) International Publication Number  
**WO 2012/025199 A1**

- (51) **International Patent Classification:**  
A61B 19/00 (2006.01) A61M 1/12 (2006.01)
- (21) **International Application Number:**  
PCT/EP2011/004063
- (22) **International Filing Date:**  
10 August 2011 (10.08.2011)
- (25) **Filing Language:** English
- (26) **Publication Language:** English
- (30) **Priority Data:**  
61/377,678 27 August 2010 (27.08.2010) US  
10075373.0 27 August 2010 (27.08.2010) EP
- (71) **Applicant (for all designated States except US):** ECP  
ENTWICKLUNGSGESELLSCHAFT MBH [DE/DE];  
Wiesenweg 10, 12247 Berlin (DE).
- (72) **Inventor; and**
- (75) **Inventor/Applicant (for US only):** SCHUMACHER,  
Jörg [DE/DE]; Potsdamer Strasse 19, 14513 Teltow  
(DE).
- (74) **Agent:** PFENNING, MEINIG & PARTNER GBR;  
Joachimstaler Strasse 12, 10719 Berlin (DE).

(81) **Designated States (unless otherwise indicated, for every kind of national protection available):** AE, AG, AL, AM, AO, AT, AU, AZ, BA, BB, BG, BH, BR, BW, BY, BZ, CA, CH, CL, CN, CO, CR, CU, CZ, DE, DK, DM, DO, DZ, EC, EE, EG, ES, FI, GB, GD, GE, GH, GM, GT, HN, HR, HU, ID, IL, IN, IS, JP, KE, KG, KM, KN, KP, KR, KZ, LA, LC, LK, LR, LS, LT, LU, LY, MA, MD, ME, MG, MK, MN, MW, MX, MY, MZ, NA, NG, NI, NO, NZ, OM, PE, PG, PH, PL, PT, QA, RO, RS, RU, SC, SD, SE, SG, SK, SL, SM, ST, SV, SY, TH, TJ, TM, TN, TR, TT, TZ, UA, UG, US, UZ, VC, VN, ZA, ZM, ZW.

(84) **Designated States (unless otherwise indicated, for every kind of regional protection available):** ARIPO (BW, GH, GM, KE, LR, LS, MW, MZ, NA, SD, SL, SZ, TZ, UG, ZM, ZW), Eurasian (AM, AZ, BY, KG, KZ, MD, RU, TJ, TM), European (AL, AT, BE, BG, CH, CY, CZ, DE, DK, EE, ES, FI, FR, GB, GR, HR, HU, IE, IS, IT, LT, LU, LV, MC, MK, MT, NL, NO, PL, PT, RO, RS, SE, SI, SK, SM, TR), OAPI (BF, BJ, CF, CG, CI, CM, GA, GN, GQ, GW, ML, MR, NE, SN, TD, TG).

**Published:**  
— with international search report (Art. 21(3))

(54) **Title:** IMPLANTABLE BLOOD CONVEYING DEVICE, MANIPULATING DEVICE AND COUPLING DEVICE

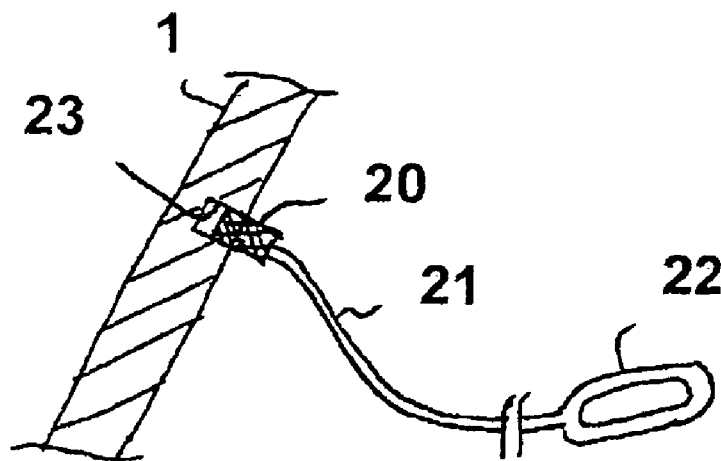

**Fig. 6**

(57) **Abstract:** The invention provides an implantable component (1) which is connectable to a manipulating device (20, 21, 22) in a self-retaining manner by means of a coupling device, which provides a first coupling element (23) and a second coupling element (20). The implantable component (1) can thus be readily positioned by the manipulating device which can, for example, already be connected to the implantable component before a therapeutic procedure and can be separated therefrom again after the surgical procedure. This is in particular advantageous with minimally invasive procedures.

WO 2012/025199 A1

5

Implantable blood conveying device, manipulating device and coupling device

10 The invention is in the field of medical engineering, in particular implant medicine, and in particular relates to the possibilities of implanting components with a minimal effort using minimally invasive procedures.

15 Implant medicine allows the use of the most varied units and elements in a patient's body for the replacement of specific organs and body parts in a temporary or permanent manner or the insertion of specific units to support bodily functions.

20 Such units can usually be put in place in a simple manner with a large opening of the patient's body, but with considerable surgical trauma arising. The reduction of surgical trauma requires smaller procedures, with the openings for introducing components into the body in part only being a little larger or even smaller, with an elastic widening, than the components to be introduced. Corresponding units can be introduced in parts and can also be assembled inside the body.

25

The minimal invasive introduction often does not allow the direct handling of components by hand so that additional instruments such as forceps are used. However, the use of such holding instruments is also not always simple. The components to be implanted are frequently designed as small as possible and also rounded so as to provide as little irritation as possible in the body, in particular with  
30 cardiac assist systems having a plurality of parts which conduct blood. On the other hand, it brings along a difficult management by corresponding holding

instruments such as forceps. A precisely targeted positioning or the assembly of individual components in the patient's body is also difficult. This can in particular be the case with cardiac assist systems when pumps, canulae and drive components have to be assembled.

5

Various aids are known from the prior art for implanting parts of cardiac assist systems into a patient's body.

10 An apparatus is known from PCT/US2008/081082 having an anchor which can be inserted close to the heart and which is connected to a guide fiber. A tubular hollow body is displaceable toward the anchor on the guide fiber and can be held there by means of a magnetic device.

15 A handling device for a canula is known from WO 2009/029387 A1 which has a guide body extending through the interior of the canula and a holding body which can be expanded radially in the manner of a cushion to hold the canula. Said holding body can be expanded so far that it jams in the interior of the canula.

20 Against the background of the prior art, it is the underlying object of the invention to provide a blood-conductive implantable component which effectively cooperates with a corresponding manipulating device to allow a reliable insertion and positioning in a patient's body with minimally invasive surgery. A further subject of the solution is a corresponding manipulating device, a coupling device for the mechanical coupling of an implantable component with a manipulating device as  
25 well as the system comprising the component and the manipulating device and a corresponding method for connecting the components to a manipulating device and for separating them.

The object is achieved by an implantable component in accordance with the invention, by a manipulating device for handling such a component, by a coupling device for the mechanical coupling of a component with a manipulating device, by a system comprising at least one implantable component and at least one  
5 manipulating device, by a corresponding method for connecting an implantable component to a manipulating device and by a method for separating an implantable component from a manipulating device.

The invention relates to an implantable component which bounds a blood-  
10 conductive passage within a human or animal body in operation, which in particular forms a part of a blood conveying device and which has a coupling element which is configured for mechanical coupling to a manipulating device, wherein the coupling between the manipulating device and the component allows a manipulation in all spatial directions. This means that the component is  
15 displaceable in freely selectable spatial directions depending on the necessities in handling. In addition, the component can also be rotatable and/or pivotable about different axes, in particular a plurality of axes. These axes can extend inside and/or outside of the implantable component and, for example, also through a coupling element. A fixed-angle connection of the coupling elements to one  
20 another in one or more planes, in particular at all sides, can in particular be provided for this purpose.

Such a component can generally be any component usable in a patient's body, in particular a part of a cardiac assist system, a blood pump, a blood pump for  
25 coupling to a heart, a valve, a canula, a catheter, corresponding connection systems between these components as well as a medicine dispensing pump.

Many of these components are equipped with particularly smooth and rounded surfaces to avoid lesions on the insertion into or dwelling in a body. This makes

the handling by the hand of the surgeon or by grasping forceps difficult. For this reason, in accordance with the invention, a coupling element is provided which is configured for the mechanical coupling of a manipulating device to the component. In this connection, a surgical instrument is, for example, understood as a  
5 manipulating device which has, for example, a handle at the proximal end facing the surgeon as well as a shaft and a distal end which is connectable to the coupling element of the component.

For this purpose, a further coupling element which is connectable to the first  
10 coupling element fastened to the implantable component or integrated therein can be provided at the distal end of the manipulating device.

A mechanical coupling is thus provided which allows a reliable manipulation of the implantable component from outside the body by means of the manipulating  
15 device both on the first implantation and later.

More than one coupling element can also be arranged at the implantable component to be able to use a plurality of manipulating devices or a divided manipulating device which can, in simplified terms, also be used in this case for  
20 the alignment of the implantable component. The plurality of coupling elements at the implantable component are spaced apart from one another at the surface of the implantable component for this purpose and can also be used to be able to select the most suitable access path depending on the implantation site.

25 The coupling element at the component is furthermore configured for the self-retaining coupling of a manipulating device. This means that the implantable component does not have to be held tight permanently by actuation of the manipulating device as is the case, for example, with various surgical forceps. The coupling between the component and the manipulating device is advantageously

designed as self-retaining so that the manipulating device can also be left out of consideration at times by the surgeon without the coupling being released.

5 The coupling devices are advantageously configured so that corresponding coupling forces are only developed between the coupling elements, for example by elastic deformation of one of the coupling elements, without forces being transmitted via the shaft of the manipulating device for this purpose.

10 The surgeon can hereby concentrate sequentially on different manipulating devices and it is ensured that the relative position of a manipulating device to the implantable component is fixed in a stable and unmovable manner.

15 The coupling element can be integrated in the component or fixedly connected thereto. In this respect, the coupling between the coupling element fastened to or integrated in the component and the manipulating device should advantageously also be releasable again in a particularly easy manner so that the manipulating device can be easily removed from the patient's body after the positioning and assembly of the implantable component.

20 The coupling element itself can in this respect, for example, be formed as an internal thread in the implantable component, preferably inside a bore and a further coupling element in the form of a threaded spigot can be screwed into it.

25 The coupling element can equally be designed as a bore or as a group of bores in the component into which bolts of a further coupling element can be introduced. Corresponding bolts can, for example, comprise metal, but also elastic materials such as rubber or also spring wire which can be introduced into the corresponding bores in a force-locking manner. A coupling element can typically also be designed as a groove, for example, having an undercut, for example, as a dovetail

groove, into which a body of a further component which is designed in a correspondingly complementary manner can be inserted.

Bores or blind holes or other openings with or without undercuts can also form a coupling element, with the respective complementary coupling element then, for example, being able to have a deformable and/or movable body having projections and/or latching elements which effect a coupling and which can either be latched by means of an actuation device or which can be deformed on the provision of a pulling force and the exceeding of a specific trigger force to separate the coupling elements. For this purpose, for example, one of the coupling elements can at least partly comprise an elastomer or a spring.

For example, the manipulating device can include a corresponding coupling element and additionally a hollow shaft which is coupled to a handle. The corresponding actuation member for latching noses or for releasing a screw connection in the region of the coupling between the coupling elements can be provided within the shaft and the actuation member can be actuatable in the region of the handle of the manipulating device.

It is also conceivable to form a coupling element as a cone which is integrated in the component, for example, a wall of the component, and into which a further cone can be pushed which forms a second coupling element which is connected to a manipulating device. The cone surfaces can, for example, be coupled to one another by a press fit, but also by means of adhesive or by a vacuum-tight closure. Skew cone clamps can also be used for such a connection.

It is moreover conceivable that one or more wrench flats at the implantable component serve as the coupling element and allow the shape-matched engagement of a corresponding coupling element of the manipulating device.

Provision can also advantageously be made that the corresponding coupling element at the component side is fastened to the implantable component, for example bonded, welded or soldered thereto or also formed in one part therewith.

5 This can be made, for example, in that a coupling plate having a threaded bore or an eyelet or a solid body, which can in turn have a bore, a groove, wrench flats or cone surfaces, is fastened to the implantable component.

The coupling element can, for example, also be formed as a smooth, surface-  
10 smoothed area onto which a suction cup serving as a second coupling element can be placed. The suction cup can, for example, be directly aerated and vented through the shaft of the manipulating device to which it is connected in order directly to establish and release the coupling between the coupling elements.

15 The connection of two smooth coupling surfaces of two coupling elements by means of an adhesive is also conceivable, with the adhesive being able to be directly dissolved or embrittled to release the connection. The adhesive can, for example, be made as a thermoplastic which can be liquefied in a short time to separate the coupling elements from one another or as a curable resin which can  
20 be embrittled by radiation cross-linking, for example by UV light, so that the adhesive bond can be easily broken.

It is also conceivable to connect the implantable component to a coupling element of the manipulating device in one piece in the manufacture by casting so that the  
25 implantable component, the coupling element connected thereto and at least one part of the manipulating device itself or the total manipulating device are made in one piece, for example in an injection molding process.



A desired break point is then provided between the coupling elements of the implantable component and of the manipulating device to be able to remove the manipulating device after the positioning of the implantable component by breaking the coupling between the coupling elements.

5

A magnet or a ferromagnetic workpiece can, for example, be provided as a coupling element at the component side which is arranged at the outer side or in the interior of the component and which cooperates with a magnet or with a ferromagnetic part of the manipulating device for the coupling. A part of a motor or of a rotor can also act as a magnet in the component, for example. A fitting surface can be provided at the outer side of the component for the coupling of the manipulating device. One of the magnets of the coupling device can be designed as a switchable electromagnet. A corresponding fitting surface can be designed, for example when it forms a part of the coupling element at the component side, as a mechanical catching device for the second coupling element associated with the manipulating device and can have a recess which has introduction chamfers or similar introduction aids for the second coupling element. An introduction chamfer can, for example, be integrated in an introduction cone, a hollow sphere or another recess tapering toward the component interior. The second coupling element can optionally have a complementary geometrical shape.

In particular when the first coupling element is formed as a fitting surface, particularly with an introduction chamber, and in particular when the fitting surface itself is not located in direct proximity to a ferromagnetic body of the component, but also in all other cases described here, the component can be designed such that the contour of the fitting surface can be reproduced by imaging processes, for example X-rays or ultrasound. This is e.g. possible by a metal surface cover of the component in the region of the fitting surface or by a marker body which has a higher density than the wall of the component and which is integrated in the

component in direct proximity of the fitting surface or with a recognizable geometrical relation to the fitting surface. A coupling can thus be established more easily and without visual contact between a manipulating device having a ferromagnetic coupling element and the component on a further invention which  
5 may become necessary after the first implantation.

An eyelet can also be provided at an outer surface of the component as a coupling element through which eyelet a thread is guided which serves as a coupling element of the manipulating device. Such a design is in particular of interest when  
10 a part of a longer flexible component such as a tubular canula should be drawn from an entry site to a target site. The coupling can then be easily separated by separation of the thread.

The associations with the component, on the one hand, and with the manipulating  
15 device, on the other hand, can generally be swapped over in the above-described complementary coupling elements.

A coupling device in accordance with the invention correspondingly provides a first coupling element which is associated with the implantable component as well as a  
20 second coupling element which is associated with the manipulating device, with the coupling elements being connectable or connected to one another in a force-locking manner and/or in a shape-matching manner and/or with material continuity.

25 The coupling device is in this respect advantageously configured so that the coupling is kept stable without an external effect.

If the coupling comprises a connection with material continuity between the first component and the second component, said connection can be separated by

breaking, cutting or changing the mechanical material properties of at least one part of the coupling device. The change in the mechanical material properties is understood, for example, as an embrittlement by radiation effect or thermal effect or a melting of a part of the coupling or a vaporizing, for example by the effect of a  
5 laser.

The invention also relates, in addition to an implantable component, a manipulating device and a coupling device, to a corresponding system having one or more components and one or more manipulating devices which are  
10 correspondingly configured to be couplable in a simple self-retaining manner by means of the coupling elements. The corresponding couplings must also be able to be released again in a simple and gentle manner inside the patient.

The invention further also relates to a method of connecting an implantable  
15 component to a manipulating device, with the component being mechanically connected to the manipulating device before the introduction into the patient's body by means of a self-retaining releasable coupling device.

This can, for example, already take place in the manufacture of the implantable  
20 component by integration of the coupling device, in that, for example, the component and at least one part of the manipulating device are manufactured in one piece together with the coupling device in an injection molding process or are connected to one another in a joining process.

25 The implantable component can also be releasably screwed, clamped, bonded or latched to the manipulating device, with a respective one of the coupling elements cooperating in a complementary manner with the other coupling element and with, for example, a threaded bore being arranged in the component and a corresponding threaded bolt at the manipulating device and with each of the

coupling elements also each being able to be provided in swappable manner at the respective other part. If, therefore, for example, an eyelet is provided at the implantable component and a corresponding hook at the manipulating device, the hook can also be provided at the implantable component and the eyelet at the  
5 manipulating device. This also applies to all other embodiments of the coupling elements.

If the implantable component and the manipulating device are already connected to one another before the start of a surgical procedure, this facilitates and  
10 accelerates the surgical procedure.

The separation of the implantable component from the manipulating device can typically only take place after the end of the implantation, for example by mechanical breaking of the coupling device or by another separation of the  
15 coupling device.

The coupling device can be mechanically weakened, for example, before the separation, e.g. by cooling, heating, irradiating, bending or by kinking the coupling device.  
20

If the method for separating the implantable component from the manipulating device takes place in manner which does not provide any displacement or movement of the manipulating device with respect to the component, this has the advantage that the positioning of the component does not have to be changed  
25 again after the end of the surgical procedure. A corresponding release of the coupling device can take place, for example, by cutting or chemical dissolving, degrading, liquefying or vaporizing of a part of the coupling device.

The invention will be shown and described in the following with reference to an embodiment in a drawing. There are shown

- 5 Fig. 1 a representation of an implantable component and of two  
manipulating devices in a three-dimensional view;
- Fig. 2 schematically in section, a manipulating device, a section of an  
implantable component and a coupling device;
- 10 Fig. 3 a view of a coupling device;
- Fig. 4 a coupling device from Fig. 3 in a plan view;
- Fig. 5 a further coupling device;
- 15 Fig. 6 a coupling device, a section of a component and a manipulating  
device;
- Fig. 7 a section of a component and a coupling device;
- 20 Fig. 8 a section of an implantable component;
- Fig. 9 a section of an implantable component with a coupling device;
- 25 Fig. 10 an alternative coupling device to that shown in Fig. 9;
- Fig. 11 a section of a component with a coupling device;

Fig. 12 a part of an implantable component in a section with a coupling device;

5 Fig. 13 a further alternative of a coupling device with a section of an implantable component; and

Fig. 14 an alternative of a coupling device with an inflatable coupling element.

10 Fig. 1 shows schematically and in a stylized fashion an implantable component 1, which, for example, represents a pump for conveying blood as a part of a cardiac assist system, having a cylindrical outer wall 2 of a pump housing and a axial rotor, which is not shown in detail, supported in the hollow cylinder.

15 A coupling element 4 of a manipulating device 5 is fastened to the end face 3 of the component 1 and is connected to a coupling element which is not shown in any more detail and which is integrated in the component 1.

20 The coupling element 4 is connected to a shaft 6 of the manipulating device 5 which is connected at its proximal end to a handle 7. A knob 8 is moreover provided at the handle 7 and can, for example, be connected to a core 9 which extends in a hollow space of the shaft 6 up to the coupling element 4.

25 The knob 8 can be moved with respect to the handle 7, for example displaced and/or rotated, to move the core 9 with respect to the shaft 6 in order thus to actuate the coupling element 4 and, for example to release the manipulating device 5 from the component 1.

A further manipulating device 5' is connected to the component 1 at another point via a further coupling element 4'. The further manipulating device 5' likewise has a handle 7' and a knob 8'. The component 1 cannot only be displaced, but also rotated by both manipulating devices 5, 5' together which are fastened at the  
5 component 1 to points spaced apart from one another.

The second manipulating device 5' can also have a core 9', which is movable by means of the knob 8', within a hollow shaft 6'.

10 Fig. 2 shows an exemplary implementation of a coupling device 10 at the component 1 having a blind hole which has an internal thread into which a threaded bolt 11 is screwed. The threaded bolt 11 is connected as a coupling element of the manipulating device to a core 9 which extends through a hollow shaft 6 and can be rotated therein to screw the threaded bolt 11 into or out of the  
15 threaded bore 10. The shaft 6 can thus be fastened to the component 1, which is only shown sectionally in Fig. 2, and released from it again.

Generally, a coupling element can be formed by a cut-pout, in particular a bore or a groove, having an undercut or without an undercut.

20

It is prevented by additional spigots at the shaft, which engage into corresponding bores of the implant, that the implant also rotates on the release of the screw connection. This moreover ensures that the implant can also be rotatingly manipulated.

25

A flange 72 can also be provided in the shaft 6 and can be screwed to the component 1 by means of the threaded bolt 11 and a head 73 of the threaded bolt by screwing into the threaded bore 10.

Fig. 3 schematically shows a coupling element 12 of a manipulating device in the form of a flat, plate-shaped thermoplastic end part at which a shaft 13 is engaged which forms a part of a manipulating device. The plate-shaped part 12 is connected to the wall piece 14, for example made in a planar fashion and forming a coupling element at the component side, for example welded thereto, bonded  
5 thereto or manufactured in one piece therewith as an injection molded part. The component 1 can thus be manipulated by means of the shaft 13 until the coupling element 12 is broken off at the component by kinking the plate 12.

10 For better clarity, this configuration is shown in a plan view in Fig. 4, with the plate 12 and the shaft 13 being recognizable. The plate 12 can be kinked and removed by pivoting in the direction of the arrows 15, 16.

The attachment of the plate-shaped piece 12 in the wall 14 of the component 1  
15 forms the coupling element which is integrated there and to which the kinkable part of the plate 12 is connected as a coupling element of the manipulating device.

In accordance with Fig. 5, a shaft 17 is connected to a bell-shaped coupling element 18 which is connected to the implantable component 1 by means of a  
20 short wire 19. The wire 19 provides that the bell 18 is seated on the component 1 and the component 1 can thus be moved by means of the shaft 17.

The wire 19 can be turned off or torn off by a rotation of the shaft 17 at its longitudinal axis or by a tilting of the bell part with a large expenditure of force to  
25 remove the manipulating device 17, 18 from the component 1. The coupling elements 18, 19 provide a good handling of the component 1 via the manipulating device as long as the connection exists.



In Fig. 6, a coupling device is shown having a coupling element 20 which comprises an elastomer and which is connected to a handle 22 of a manipulating device by means of a shaft 21. The element 20 is fixed in a force-locking manner in a bore 23 as a coupling element of an implementable component 1. For  
5 example, the element 20 can be heated and pressed into the bore 23 to establish a connection of the coupling device 20, 23. The manipulating device 20, 21, 22 can subsequently be removed from the component 1 by pulling at the shaft 21. It is also conceivable previously to heat the coupling element 20 or to cool it considerably to allow it to shrink.

10

In Fig. 7, a coupling device is shown having a first component 1 onto which a coupling element in the form of a plate 24 is set, for example welded, soldered or bonded. The plate 24 can also be designed as an integrated part of the component 1.

15

A suction cup 25 is placed on the smooth surface of the coupling element 24 and can, for example, comprise an elastomer, but also a hard highly polished plate, for example of steel. The two plates 24, 25 adhere as coupling elements to one another in a sucking manner with a sufficient surface quality. This is in particular  
20 the case when one of the components is formed as an elastomer suction cup.

A ventilating passage 26 can be provided within the second coupling element 25; it extends through the shaft 27 and can be aerated or evacuated from the proximal end of the manipulating device 25, 26, 27 to couple or release the coupling device  
25 24, 25.

In Fig. 8, a section of an implantable component 51 is shown schematically having a dovetail groove 28 or a bore having undercuts.

If it is a radially symmetrical bore having undercuts, in accordance with Fig. 9, a tulip-like coupling element 29 having outwardly facing latching noses can thus be inserted therein which elastically latch into the undercuts of the bore 28. The coupling element 29 is connected to a shaft 30 of a manipulating device and can  
5 also only be pulled out of the bore 28 by sufficient pulling at this shaft 30 when a blocking element 51 in the form of a cylinder is spaced apart axially from the latching noses 29 within a cut-out 52 in the manipulation apparatus by means of movement of the core 53 and thus releases an inward movement of the latching noses. The shaft 30 is hollow to receive the core 53.

10

Another constellation of a coupling element 31 is shown in Fig. 10 which is equally arranged in a bore of the implantable component 1 having undercuts and which is substantially cylindrical with outwardly facing latching noses of elastically bendable end regions of end fingers of the coupling element. The coupling element 31 is  
15 also fixedly seated in the bore 28, but can be pulled out thereof by expenditure of force or by pulling in the latching noses of the coupling element 31.

Fig. 11 shows a coupling apparatus having a first coupling element 32 and a second coupling element 33 which are each formed in plate-shape. The first  
20 coupling element 32 is fastened to a section of an implantable component 1 by bonding, welding or other joining technique and has a planar, smooth surface on the side remote from the component 1. The second coupling element 33 is laid onto the surface and is fastened there, for example, by means of an adhesive, e.g. an epoxy resin or another curable resin.

25

The coupling elements are thereby connected to one another and the shaft 34 of a manipulating device is connected in a fixed and self-retaining manner to the component 1 via this coupling apparatus.

The connection can be permanently established, for example, before introduction of the component 1 into a patient's body.

To release the coupling connection, the epoxy resin between the coupling  
5 elements 32, 33 can be rehardened so much, for example by means of a UV radiation source 35, that it becomes brittle so that the coupling elements 32, 33 can easily be separated from one another.

Provision can, however, also be made that the coupling elements 32, 33 are  
10 connected to one another by a thermoplastic adhesive which can be liquefied by irradiation, for example by a heat source, so that the coupling can be dissolved in this manner and the manipulating device can be removed by separation of the second coupling element 33 from the first coupling element 32. Ultrasonic pulses or laser beams can also be used to dissolve the coupling.

15

A constellation is shown in Fig. 12 in which a hollow cylindrical component 1 as a coupling element has, for example, a spherical fitting surface 54 and two conical fitting surfaces 55, 56. The complementary cone 57 can run into the fitting surface 56 parallel to the longitudinal axis of the cylindrical component 1; the  
20 complementary bodies 58, 59 can move radially into the other fitting surfaces. The bodies 57, 58, 59 each represent coupling elements of a manipulating device and can be formed as ferromagnetic bodies, optionally as magnets, and also as switchable electromagnets.

25 The fitting surfaces 54, 55, 56 can each be surrounded by ferromagnetic and/or magnetized material of the component 1, as shown for the example of the fitting surface 56 by hatching of the magnetic region 60.

Provision can also be made that the magnetic effect of magnetically effective parts 61 in the interior of the component 1, for example of parts of a pump drive or of a magnetic valve, are used for the coupling.

- 5 To facilitate a coupling of the manipulating device to the component by means of imaging processes, a marker body 70 integrated in the wall of the component or a surface coat 71 of a fitting surface 54 comprising a material of high density, in particular metal, preferably a precious metal, chromium or surgical steel, can be provided.

10

To release such a magnetic coupling, either a corresponding electromagnet can be switched off or the manipulation apparatus can be moved in a jerky manner. A demagnetization of the magnets by means of an alternating field can also take place. A different alignment of the magnetic poles with respect to one another can  
15 however, also be achieved by rotating the one magnet with respect to the other so that a simplified release is made possible by the magnetic repelling forces which arise.

In Fig. 13, a coupling apparatus is shown having a plate 32' which is jointed to an  
20 implantable component 1 and which has a blind bore 44 having an internal thread. The plate 32' having the blind bore 44 in this respect represents a first coupling element of the component 1. A second coupling element can be connected to this first coupling element and has a threaded bolt 45 which is connected to a core 46. The core 46 extends in the hollow space of a shaft 47 which represents a part of a  
25 manipulating device and is proximally connected to a handle not shown in Fig. 13. The shaft 47 and the core 46 are connected to the coupling element 32' of the implantable component 1 by means of the threaded bolt 44.

If the core 46 is rotated with respect to the shaft 47 via a knob at the handle of the manipulating device, the threaded bolt 45 can hereby be screwed into the plate 32' or out of it or of the threaded bore 44 in order to establish or separate the coupling depending on the situation.

5

In the state of an established coupling, the coupling apparatus is self-retaining, i.e. the first component 1 can easily be displaced and positioned or rotated as desired at the handle, not shown, of the manipulating device.

10 The threaded bolt 47 can selectively also be replaced with a nut having an internal thread connected to the core 46 and the threaded bore 44 with a corresponding threaded bolt.

As a further embodiment, the implantable component can also have a wrench flat, for example a hexagonal flat, as a coupling element to which a complementary wrench can engage as a second coupling element. If this combination is designed in a press fit, the connection is self-retaining.

15 Provision is advantageously made in the described coupling devices to form them at the implant at the surface not conducting blood. Any contamination or damage to the passage conducting blood can thereby be prevented. In addition, any cut-outs, bores or the like provided are not provided at the blood conducting passage so that dead flow regions are avoided.

20 As shown in Fig. 14, a combination of an inflatable hollow body, in particular of cushion, on the one hand, and of a gripping surface, on the other hand, can also be provided as a coupling device, for example at the component side.

For example, a cushion inflatable via the shaft of a manipulating device can be introduced into a hollow space of a component and inflated there. For this purpose, the corresponding hollow space can have an undercut. The inflatable hollow body can also be made as a torus 63, 64 and be pushed over the  
5 component 1 or a part 62 of the component and inflated there.

As soon as the implant has been positioned and aligned, the pressure in the hollow body can be reduced and the coupling apparatus thus separated.

10 The hollow body can be coated with an elastomer for better adhesion to the component and to save the component surfaces.

A fluid passage 66 is in each case provided in the shaft 65 of the manipulating device for inflating and pressure reducing of the hollow body. Beads 67, 68 can be  
15 provided at the component 1 for holding the hollow body which thus form corresponding fitting surfaces as a coupling element at the component side.

The component can be simply positioned and aligned by a surgeon by the different variants shown of a self-retaining coupling apparatus between an implantable  
20 component and a manipulating device without the hand of the surgeon having to be directly guided into the operating field. A comparatively small access to the operating field is thereby made possible. The connection between the instrument or the manipulating device, on the one hand, and the component, on the other hand, can already be established before the actual surgical procedure and can be  
25 dissolved after the implantation.

The manipulating device, the coupling device and the implantable component can be characterized generally by the following principles of action as special aspects of the invention:

- 1st aspect: the provision of fixed wrench flats at the component which cooperate with a complementary form of a coupling element;
- 5 2nd aspect: the coupling via a force locking (clamping) by an inflatable body or by a body of a coupling element spreadable in an opening;
- 3rd aspect: the coupling simultaneously at two points spaced apart from one another at the component, whereby the rotatability and tiltability is improved as a consequence of the separate manipulation possibilities of the coupling points;
- 10
- 4th aspect: the magnetic coupling of a coupling element of the manipulating device to a magnetically active part of the implantable component, in particular a drive unit, further particularly a pump unit.
- 15

## Claims

5

1. An implantable component (1) which bounds a passage conducting blood within a human or animal body in operation and which in particular forms a part of a blood conveying device, in particular of a blood pump for coupling to a heart, characterized by a coupling element (10, 14, 19, 23, 24, 28, 32, 32', 44, 54, 55, 56, 62, 67 68) which is arranged at a surface of the component remote from the blood-conductive passage and which is configured for the releasable mechanical coupling of a manipulating device (5, 6, 7, 8, 9, 5', 6', 7', 8', 9', 13, 17, 21, 22, 26, 27, 57, 58, 59), wherein the coupling between the manipulating device and the component enables a manipulation in all spatial directions.

10

15

2. An implantable component in accordance with claim 1, characterized in that the coupling element (10, 14, 19, 23, 24, 28, 32, 32', 44, 54, 55, 56, 62, 67 68) is configured for self-retaining coupling to a manipulating device (5, 6, 7, 8, 9, 5', 6', 7', 8', 9', 13, 17, 21, 22, 26, 27, 57, 58, 59).

20

3. An implantable component in accordance with either of claims 1 or 2, characterized in that the coupling element (10, 14, 19, 23, 24, 28, 32, 32', 44, 54, 56, 62, 67 68) is integrated into the component (1).

25

4. An implantable component in accordance with either of claims 1 or 2, characterized in that the coupling element (10, 14, 19, 23, 24, 28, 32, 32', 44) is fixedly connected to the component (1).



5. An implantable component in accordance with one of the claims 1 to 4, characterized in that the coupling element has a mechanical catching apparatus for a further coupling element of a manipulating device, with the catching apparatus in particular having an introduction chamfer, in particular a conical, pyramidal or spherical shape.
6. An implantable component in accordance with one of the claims 1 to 5, characterized in that a marker element (70, 71) in the form of a surface coat (71) and/or of a marker body (70) arranged in the wall of the component is integrated into the component, said marker element being able to be reproduced by means of an imaging process.
7. A manipulating device (5, 6, 7, 8, 9, 5', 6', 7', 8', 9', 13, 17, 21, 22, 26, 27) for handling a component of a system for blood conveying (1) implantable into a patient's body, characterized by a further coupling element (4, 4', 11, 12, 19, 20, 25, 29, 31, 33, 36, 37, 45, 57, 58, 59, 63, 64) which is configured for mechanical coupling to an implantable component (1).
8. A manipulating device in accordance with claim 7, characterized in that the coupling element is configured for self-retaining coupling of a manipulating device.
9. A manipulating device in accordance with claim 8, characterized in that a magnet or a ferromagnetic body is provided, in particular a switchable electromagnet, as a further coupling element (57, 58, 59).
10. A coupling device for the mechanical coupling of a component of a system for blood conveying (1) implantable into a patient's body to a manipulating device (5, 6, 7, 8, 9, 5', 6', 7', 8', 9', 13, 17, 21, 22, 26, 27) on the one hand,

characterized, on the other hand, by a first coupling element (10, 14, 19, 23, 24, 28, 32, 32', 44, 54, 55, 56) associated with the implantable component and a second coupling element (4, 4', 11, 12, 19, 20, 25, 29, 31, 33, 45, 57, 58, 59) associated with the manipulating device, with the first and second  
5 coupling elements being connectable to one another in a force-locking manner and/or a shape-matching manner and/or with material continuity or by magnetic forces.

11. A coupling device in accordance with claim 10, characterized in that the first  
10 and second coupling elements are configured connectable to one another such that the coupling of the coupling elements is made self-retaining.
12. A coupling device in accordance with either of claims 10 or 11,  
15 characterized in that the first and second coupling elements are connected to one another such that a connection with material continuity between the first coupling element and the second coupling element can be separated by breaking, cutting or changing the mechanical material properties of at least one part of the coupling device.
- 20 13. A system for blood conveying having at least one implantable component (1) and having at least one manipulating device (5, 6, 7, 8, 9, 5', 6', 7', 8', 9', 13, 17, 21, 22, 26, 27), characterized in that the system has at least one coupling device in accordance with one of the claims 10 to 12.
- 25 14. A method of handling an implantable component of a system for blood conveying (1) having a manipulating device (5, 6, 7, 8, 9, 5', 6', 7', 8', 9', 13, 17, 21, 22, 26, 27), characterized in that the component (1) is mechanically connected to the manipulating device before the introduction into the patient's body by means of a self-retaining, releasable coupling device.

15. A method in accordance with claim 14, characterized in that the component and the manipulating device are held together by magnetic forces, in particular using an electromagnet to which current is applied.
- 5
16. A method of separating an implantable component (1) from a manipulating device (5, 6, 7, 8, 9, 5', 6', 7', 8', 9', 13, 17, 21, 22, 26, 27), wherein the component and the manipulating device are mechanically connected to one another by means of a self-retaining coupling device, characterized in that
- 10 the coupling device is broken mechanically or in another destructive manner.
17. A method of separating an implantable component (1) from a manipulation device in accordance with claim 16, characterized in that a part of the
- 15 coupling device is mechanically weakened before the separation.
18. A method of separating an implantable component from a manipulation device in accordance with claim 16, characterized in that the elements of the coupling device are separated from one another by an actuation of the
- 20 manipulating device which is different from a displacement of the manipulating device with respect to the component.

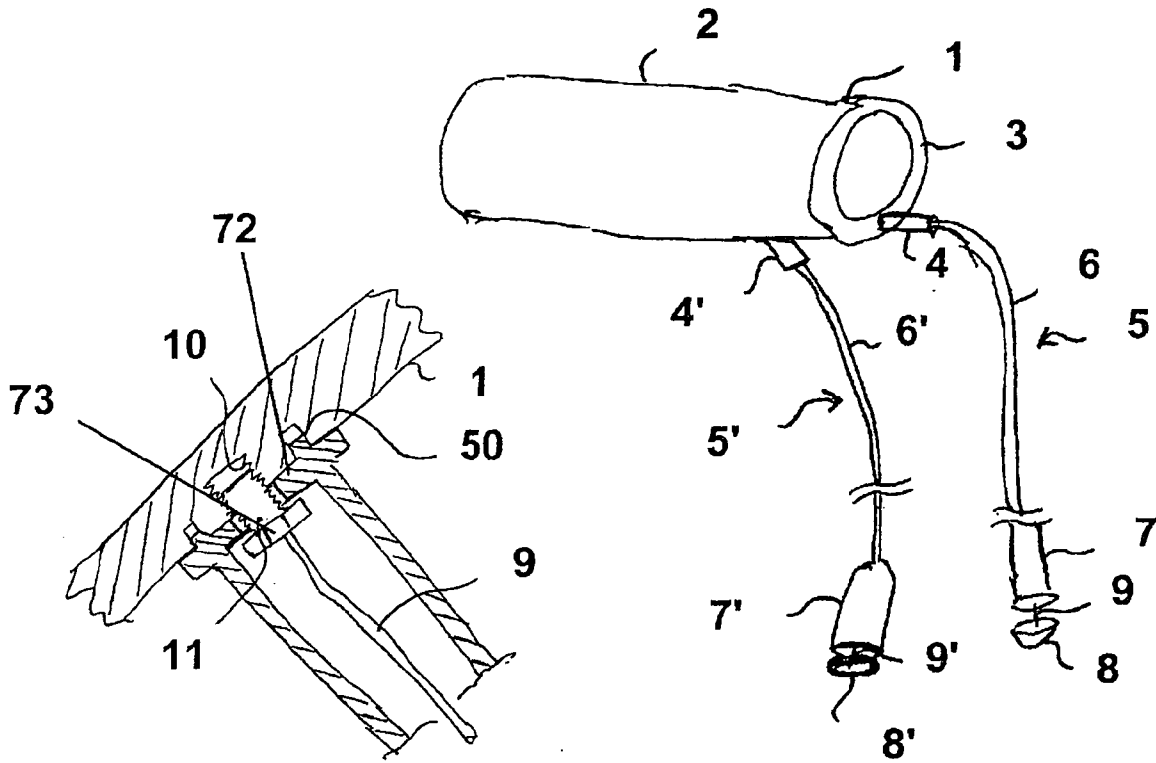

Fig. 2

Fig. 1

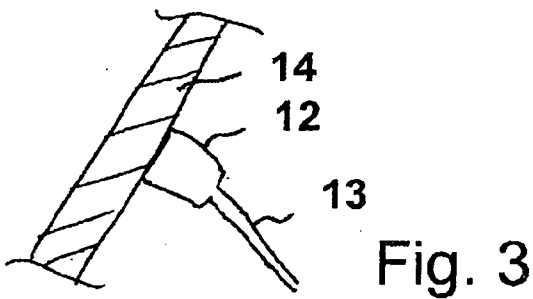

Fig. 3

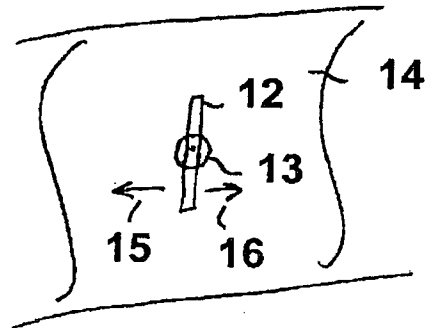

Fig. 4

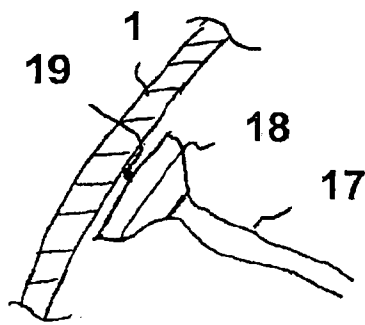

Fig. 5

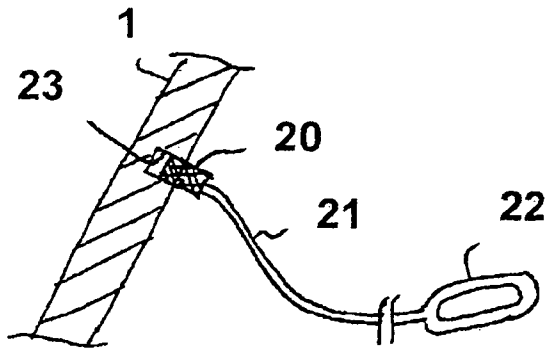

Fig. 6

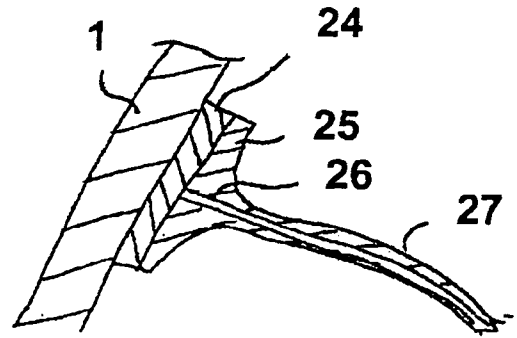

Fig. 7

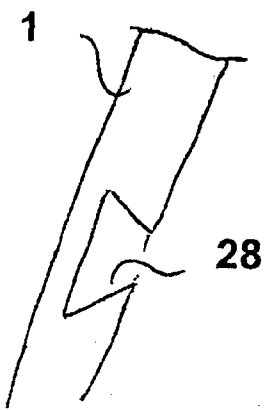

Fig. 8

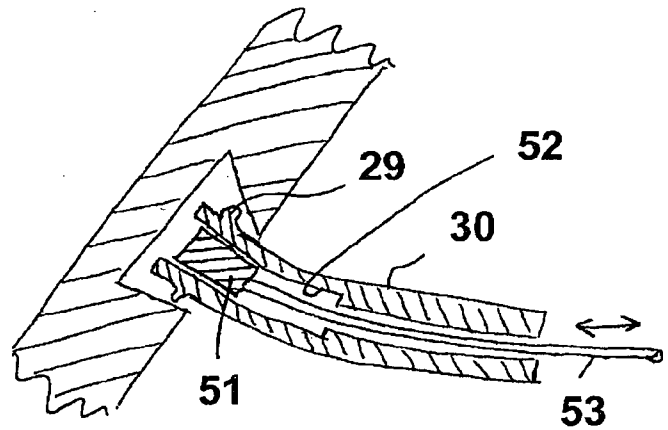

Fig. 9

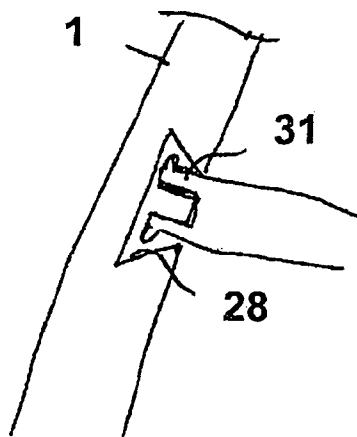

Fig. 10

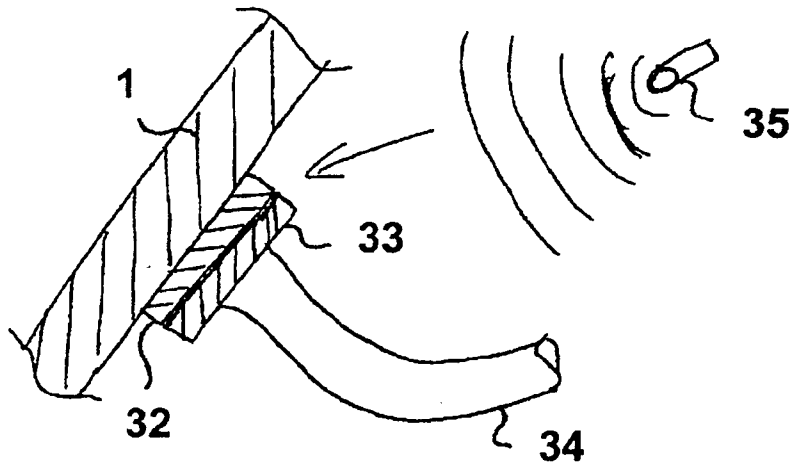

Fig. 11

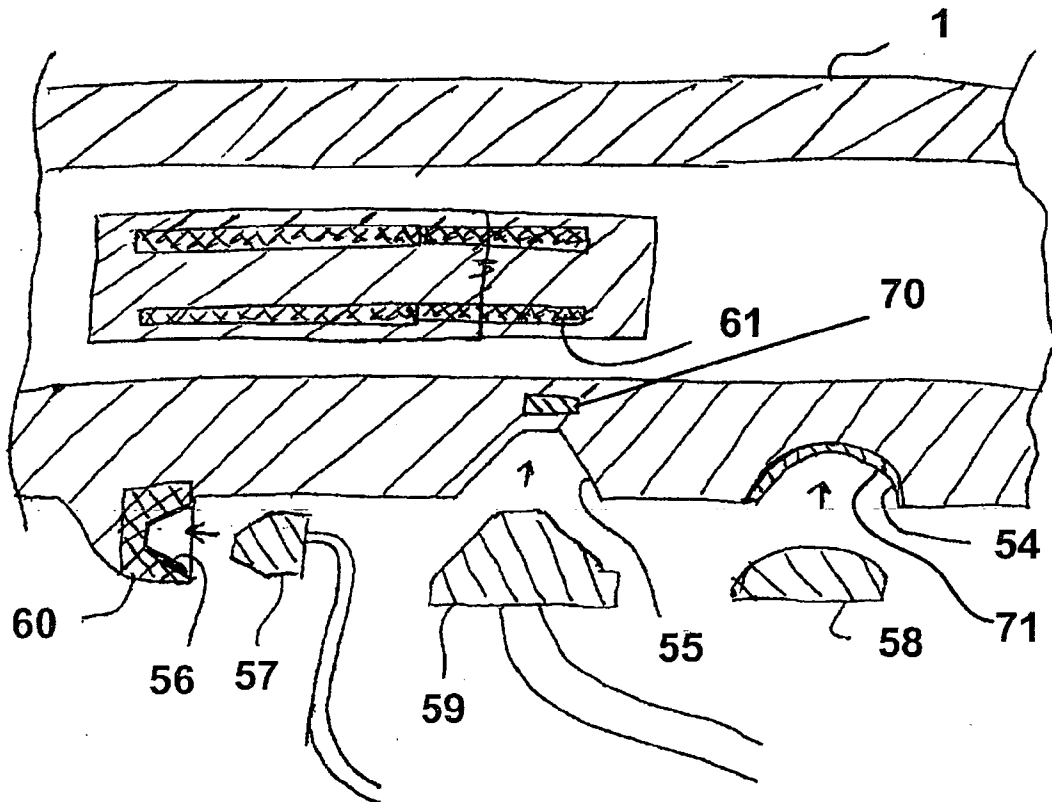

Fig. 12

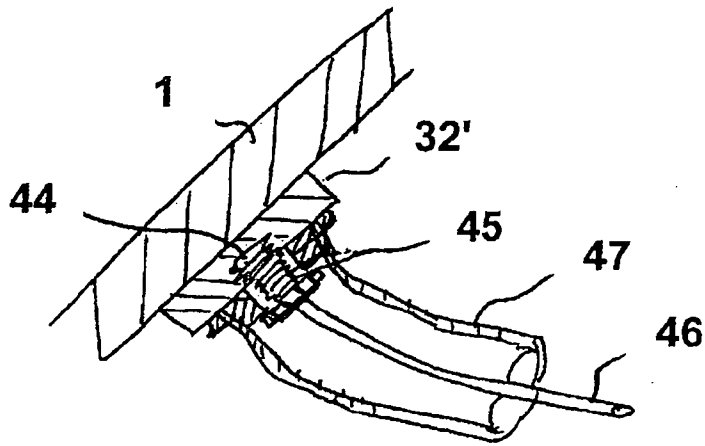

Fig. 13

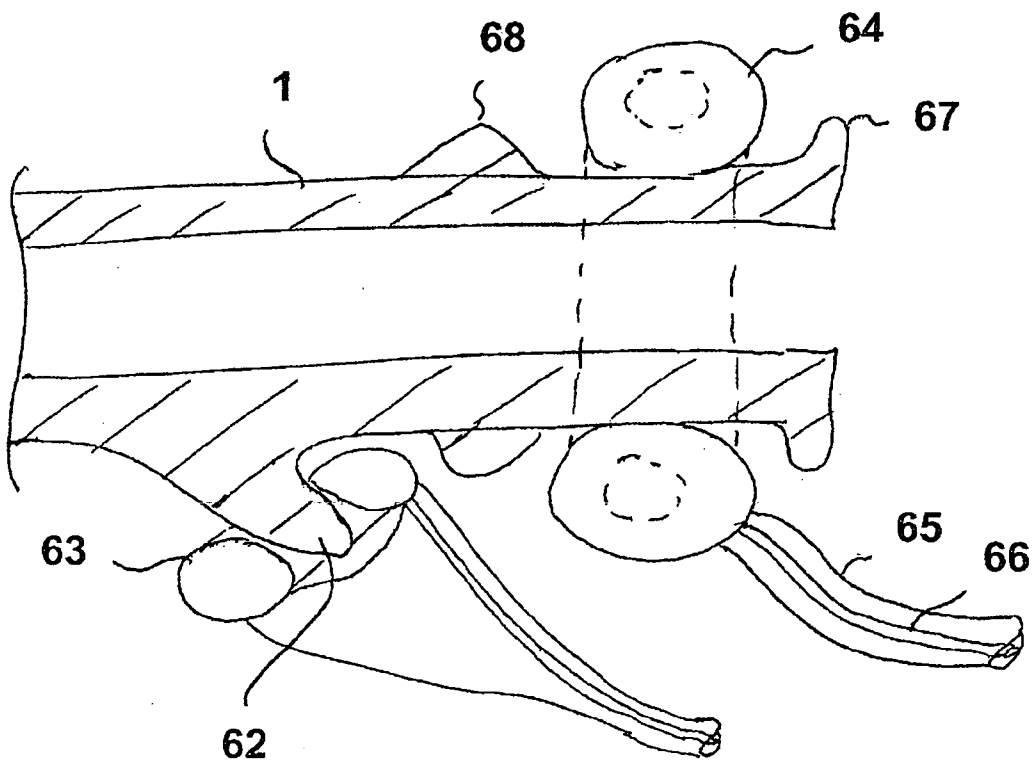

Fig. 14

INTERNATIONAL SEARCH REPORT

International application No  
PCT/EP2011/004063

A. CLASSIFICATION OF SUBJECT MATTER  
INV. A61B19/00 A61M1/12  
ADD.  
According to International Patent Classification (IPC) or to both national classification and IPC

B. FIELDS SEARCHED  
Minimum documentation searched (classification system followed by classification symbols)  
A61B A61M A61F

Documentation searched other than minimum documentation to the extent that such documents are included in the fields searched

Electronic data base consulted during the international search (name of data base and, where practical, search terms used)  
EPO-Internal

C. DOCUMENTS CONSIDERED TO BE RELEVANT

Category*	Citation of document, with indication, where appropriate, of the relevant passages	Relevant to claim No.
X	US 7 344 553 B2 (OPOLSKI STEVEN W [US] ET AL) 18 March 2008 (2008-03-18)	1-5,7-15
Y	column 4, lines 26-30 column 5, lines 17-29 column 7, lines 15-21; figure 2A	6
Y	US 2009/112050 A1 (FARNAN ROBERT C [US] ET AL) 30 April 2009 (2009-04-30) cited in the application paragraph [0106]; figure 8B	6
X	US 5 853 420 A (CHEVILLON GERARD [FR] ET AL) 29 December 1998 (1998-12-29) column 9, lines 35-47; figure 9	16-18

Further documents are listed in the continuation of Box C.

See patent family annex.

\* Special categories of cited documents :

- "A" document defining the general state of the art which is not considered to be of particular relevance
- "E" earlier document but published on or after the international filing date
- "L" document which may throw doubts on priority claim(s) or which is cited to establish the publication date of another citation or other special reason (as specified)
- "O" document referring to an oral disclosure, use, exhibition or other means
- "P" document published prior to the international filing date but later than the priority date claimed

- "T" later document published after the international filing date or priority date and not in conflict with the application but cited to understand the principle or theory underlying the invention
- "X" document of particular relevance; the claimed invention cannot be considered novel or cannot be considered to involve an inventive step when the document is taken alone
- "Y" document of particular relevance; the claimed invention cannot be considered to involve an inventive step when the document is combined with one or more other such documents, such combination being obvious to a person skilled in the art.
- "&" document member of the same patent family

Date of the actual completion of the international search  17 November 2011	Date of mailing of the international search report  24/11/2011
---	--

Name and mailing address of the ISA/ European Patent Office, P.B. 5818 Patentlaan 2 NL - 2280 HV Rijswijk Tel. (+31-70) 340-2040, Fax: (+31-70) 340-3016	Authorized officer  Böttcher, Stephanie
--	---



# INTERNATIONAL SEARCH REPORT

Information on patent family members

International application No

PCT/EP2011/004063

Patent document cited in search report	Publication date	Patent family member(s)	Publication date	
US 7344553	B2	18-03-2008	US 2003181945 A1	25-09-2003
			US 2008154302 A1	26-06-2008
-----				
US 2009112050	A1	30-04-2009	CA 2702609 A1	30-04-2009
			EP 2203213 A1	07-07-2010
			JP 2011500286 A	06-01-2011
			US 2009112050 A1	30-04-2009
			US 2011190567 A1	04-08-2011
			US 2011190707 A1	04-08-2011
			WO 2009055651 A1	30-04-2009
-----				
US 5853420	A	29-12-1998	NONE	
-----				