

(19) World Intellectual Property Organization
International Bureau



(43) International Publication Date
16 April 2009 (16.04.2009)

PCT

(10) International Publication Number
WO 2009/046717 A3

(51) International Patent Classification:

G01S 17/58 (2006.01) G01S 7/497 (2006.01)
G01S 7/481 (2006.01) G01S 17/95 (2006.01)
G01S 7/499 (2006.01)

(21) International Application Number:

PCT/DK2008/000350

(22) International Filing Date: 8 October 2008 (08.10.2008)

(25) Filing Language: English

(26) Publication Language: English

(30) Priority Data:

PA 2007 01457 9 October 2007 (09.10.2007) DK
PA 2008 00721 26 May 2008 (26.05.2008) DK

(71) Applicant (for all designated States except US): DAN-
MARKS TEKNISKE UNIVERSITET [DK/DK]; Anker
Engelundsvej 1, DTU-bygning 101A, DK-2800 Kgs. Lyn-
gby (DK).

(71) Applicant (for US only): PEDERSEN, Christian
[DK/DK]; Willemoesgade 22. 1. tv., DK-2100 Kobenhavn
ø. (DK).

(72) Inventor; and

(75) Inventor/Applicant (for US only): HANSEN, Rene,
Skov [DK/DK]; Risø Huse 27, Dk-4000 Roskilde (DK).

(74) Agent: ALBIHNS A/S; Havneholmen 29, bygn. 2, 3. sal,
DK-1561 Cøbenhavn V. (DK).

(81) Designated States (unless otherwise indicated, for every
kind of national protection available): AE, AG, AL, AM,
AO, AT, AU, AZ, BA, BB, BG, BH, BR, BW, BY, BZ, CA,
CH, CN, CO, CR, CU, CZ, DE, DK, DM, DO, DZ, EC, EE,
EG, ES, FI, GB, GD, GE, GH, GM, GT, HN, HR, HU, ID,
IL, IN, IS, JP, KE, KG, KM, KN, KP, KR, KZ, LA, LC, LK,
LR, LS, LT, LU, LY, MA, MD, ME, MG, MK, MN, MW,
MX, MY, MZ, NA, NG, NI, NO, NZ, OM, PG, PH, PL, PT,
RO, RS, RU, SC, SD, SE, SG, SK, SL, SM, ST, SV, SY, TJ,
TM, TN, TR, TT, TZ, UA, UG, US, UZ, VC, VN, ZA, ZM,
ZW.

(84) Designated States (unless otherwise indicated, for every
kind of regional protection available): ARIPO (BW, GH,
GM, KE, LS, MW, MZ, NA, SD, SL, SZ, TZ, UG, ZM,
ZW), Eurasian (AM, AZ, BY, KG, KZ, MD, RU, TJ, TM),
European (AT, BE, BG, CH, CY, CZ, DE, DK, EE, ES, FI,
FR, GB, GR, HR, HU, IE, IS, IT, LT, LU, LV, MC, MT, NL,
NO, PL, PT, RO, SE, SI, SK, TR), OAPI (BF, BJ, CF, CG,
CI, CM, GA, GN, GQ, GW, ML, MR, NE, SN, TD, TG).

Published:

- with international search report
- before the expiration of the time limit for amending the
claims and to be republished in the event of receipt of
amendments

(88) Date of publication of the international search report:
28 May 2009

(54) Title: COHERENT LIDAR SYSTEM BASED ON A SEMICONDUCTOR LASER AND AMPLIFIER

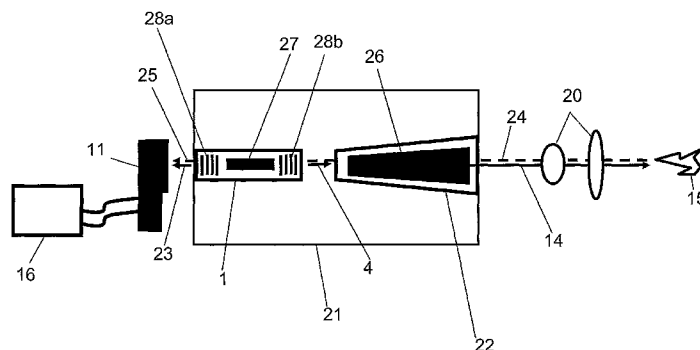

Fig. 1

(57) Abstract: The present invention relates to a compact, reliable and low-cost coherent LIDAR (Light Detection And Ranging) system for remote wind-speed determination, determination of particle concentration, and/or temperature based on an all semiconductor light source and related methods. The present invention provides a coherent LIDAR system comprising a semiconductor laser for emission of a measurement beam of electromagnetic radiation directed towards a measurement volume for illumination of particles in the measurement volume, a reference beam generator for generation of a reference beam, a detector for generation of a detector signal by mixing of the reference beam with light emitted from the particles in the measurement volume illuminated by the measurement beam, and a signal processor for generating a velocity signal corresponding to the velocity of the particles based on the detector signal.



WO 2009/046717 A3

INTERNATIONAL SEARCH REPORT

International application No
PCT/DK2008/000350

A. CLASSIFICATION OF SUBJECT MATTER
 INV. **G01S17/58** **G01S7/481** **G01S7/499** **G01S7/497** **G01S17/95**

According to International Patent Classification (IPC) or to both national classification and IPC

B. FIELDS SEARCHED

Minimum documentation searched (classification system followed by classification symbols)
G01S

Documentation searched other than minimum documentation to the extent that such documents are included in the fields searched

Electronic data base consulted during the international search (name of data base and, where practical, search terms used)
EPO-Internal, WPI Data, INSPEC

C. DOCUMENTS CONSIDERED TO BE RELEVANT		
Category*	Citation of document, with indication, where appropriate, of the relevant passages	Relevant to claim No.
X	HARRIS M ET AL: "CONTINUOUS-WAVE BISTATIC LASER DOPPLER WIND SENSOR" APPLIED OPTICS, OSA, OPTICAL SOCIETY OF AMERICA, WASHINGTON, DC, vol. 40, no. 9, 20 March 2001 (2001-03-20), pages 1501-1506, XP001066006 ISSN: 0003-6935	1-3, 7, 10, 12, 13, 17, 19, 22, 25-27, 34-36
Y	page 1501 - page 1502; figure 1	4, 8, 9, 11, 23, 28
A		5, 6, 24, 29, 39
Y	WO 2004/012994 A (OPHIR CORP [US]; NELSON LOREN D [US]; WEIMER CARL S [US]; CALDWELL LOR) 12 February 2004 (2004-02-12) page 4, paragraph 2	4, 28
	----- -/--	

Further documents are listed in the continuation of Box C. See patent family annex.

* Special categories of cited documents :

A document defining the general state of the art which is not considered to be of particular relevance	*T* later document published after the international filing date or priority date and not in conflict with the application but cited to understand the principle or theory underlying the invention
E earlier document but published on or after the international filing date	*X* document of particular relevance; the claimed invention cannot be considered novel or cannot be considered to involve an inventive step when the document is taken alone
L document which may throw doubts on priority claim(s) or which is cited to establish the publication date of another citation or other special reason (as specified)	*Y* document of particular relevance; the claimed invention cannot be considered to involve an inventive step when the document is combined with one or more other such documents, such combination being obvious to a person skilled in the art
O document referring to an oral disclosure, use, exhibition or other means	*&* document member of the same patent family
P document published prior to the international filing date but later than the priority date claimed	

Date of the actual completion of the international search 23 January 2009	Date of mailing of the international search report 26/03/2009
---	---

Name and mailing address of the ISA/ European Patent Office, P.B. 5818 Patentlaan 2 NL - 2280 HV Rijswijk Tel. (+31-70) 340-2040, Fax: (+31-70) 340-3016	Authorized officer Devine, John
--	---

INTERNATIONAL SEARCH REPORT

International application No

PCT/DK2008/000350

C(Continuation). DOCUMENTS CONSIDERED TO BE RELEVANT		
Category*	Citation of document, with indication, where appropriate, of the relevant passages	Relevant to claim No.
Y	US 7 027 475 B1 (ZEDIKER MARK S [US] ET AL) 11 April 2006 (2006-04-11) - paragraph [0047] - paragraph [0053]; figures 4a-4h -----	8,9,11
Y	US 2007/075546 A1 (AVAGLIANO AARON [US] ET AL AVAGLIANO AARON [US] ET AL) 5 April 2007 (2007-04-05) the whole document -----	23
A	US 5 689 363 A (DANE C BRENT [US] ET AL) 18 November 1997 (1997-11-18) column 5, line 35 - column 6, line 32 -----	10,11
A	WO 94/10729 A (BRITISH TECH GROUP [GB]; SIBBETT WILSON [GB]) 11 May 1994 (1994-05-11) page 14 - page 15 -----	10
A	WO 01/06473 A (GOU LITE LTD [IL]; KINROT URI [IL]) 25 January 2001 (2001-01-25) page 14, line 7 - line 14 page 5, line 10 - line 13 page 14, line 25 - page 15, line 10 page 16, line 3 - line 12 page 26, line 26 - page 27, line 15; figures 1,4a,4b -----	1,25,34
A	-----	6,14
A	US 5 164 784 A (WAGGONER ALAN P [US]) 17 November 1992 (1992-11-17) the whole document -----	1

INTERNATIONAL SEARCH REPORT

International application No.
PCT/DK2008/000350

Box No. II Observations where certain claims were found unsearchable (Continuation of item 2 of first sheet)

This international search report has not been established in respect of certain claims under Article 17(2)(a) for the following reasons:

1. Claims Nos.:
because they relate to subject matter not required to be searched by this Authority, namely:

2. Claims Nos.:
because they relate to parts of the international application that do not comply with the prescribed requirements to such an extent that no meaningful international search can be carried out, specifically:

3. Claims Nos.:
because they are dependent claims and are not drafted in accordance with the second and third sentences of Rule 6.4(a).

Box No. III Observations where unity of invention is lacking (Continuation of item 3 of first sheet)

This International Searching Authority found multiple inventions in this international application, as follows:

see additional sheet

1. As all required additional search fees were timely paid by the applicant, this international search report covers all searchable claims.

2. As all searchable claims could be searched without effort justifying an additional fees, this Authority did not invite payment of additional fees.

3. As only some of the required additional search fees were timely paid by the applicant, this international search report covers only those claims for which fees were paid, specifically claims Nos.:

4. No required additional search fees were timely paid by the applicant. Consequently, this international search report is restricted to the invention first mentioned in the claims; it is covered by claims Nos.:
1-13, 17, 19, 22-29, 34-36, 39

Remark on Protest

- The additional search fees were accompanied by the applicant's protest and, where applicable, the payment of a protest fee.
- The additional search fees were accompanied by the applicant's protest but the applicable protest fee was not paid within the time limit specified in the invitation.
- No protest accompanied the payment of additional search fees.

FURTHER INFORMATION CONTINUED FROM PCT/ISA/ 210

This International Searching Authority found multiple (groups of) inventions in this international application, as follows:

1. claims: 1-13,17,19,22-29,34-36,39

Coherent lidar with features of claim 1 is known from XP1066006, therefore, a posteriori 1st inventive subject is in claim 5: lidar with detection of particle concentration in mesurement volume

2. claims: 14-16,30,37

spatial filter in beam

3. claim: 18

beam splitter and beam combiner optical system

4. claims: 20,21,31,38

beam clean up device

5. claims: 32,33

trimming wind propulsion surfaces

INTERNATIONAL SEARCH REPORT

Information on patent family members

International application No

PCT/DK2008/000350

Patent document cited in search report	A	Publication date	Patent family member(s)	Publication date
WO 2004012994	A	12-02-2004	AT 361472 T AU 2003268051 A1 CA 2494458 A1 DE 60313616 T2 EP 1525484 A2	15-05-2007 23-02-2004 12-02-2004 31-01-2008 27-04-2005

US 7027475	B1	11-04-2006	NONE	

US 2007075546	A1	05-04-2007	AU 2006203289 A1 BR PI0603291 A CA 2552670 A1 CN 1940289 A EP 1770278 A2	19-04-2007 14-08-2007 30-03-2007 04-04-2007 04-04-2007

US 5689363	A	18-11-1997	WO 9642129 A1	27-12-1996

WO 9410729	A	11-05-1994	NONE	

WO 0106473	A	25-01-2001	AU 5843300 A CN 1367877 A EP 1234286 A2 JP 2003505676 T	05-02-2001 04-09-2002 28-08-2002 12-02-2003

US 5164784	A	17-11-1992	NONE	
