



- (51) International Patent Classification:  
*B26D 7/00* (2006.01)
- (21) International Application Number:  
PCT/US2015/013397
- (22) International Filing Date:  
29 January 2015 (29.01.2015)
- (25) Filing Language: English
- (26) Publication Language: English
- (30) Priority Data:  
14153724.1 3 February 2014 (03.02.2014) EP
- (71) Applicant: **3M INNOVATIVE PROPERTIES COMPANY** [US/US]; 3M Center, Post Office Box 33427, Saint Paul, Minnesota 55133-3427 (US).
- (72) Inventors: **SEKANINA, Martin**; V Parku 2343/24, 148 00 Praha 4 (CZ). **MARSOUN, Lukas**; V Parku 2343/24, 148 00 Praha 4 (CZ). **MELEZINEK, Rudolf**; V Parku 2343/24, 148 00 Praha 4 (CZ). **LUDVIK, Petr**; Wuchterlova 8/1609, 160 00 Praha 6 (CZ).
- (74) Agents: **KNECHT, Harold C., III** et al.; 3M Center, Office of Intellectual Property Counsel, Post Office Box 33427, Saint Paul, Minnesota 55133-3427 (US).

- (81) Designated States (unless otherwise indicated, for every kind of national protection available): AE, AG, AL, AM, AO, AT, AU, AZ, BA, BB, BG, BH, BN, BR, BW, BY, BZ, CA, CH, CL, CN, CO, CR, CU, CZ, DE, DK, DM, DO, DZ, EC, EE, EG, ES, FI, GB, GD, GE, GH, GM, GT, HN, HR, HU, ID, IL, IN, IR, IS, JP, KE, KG, KN, KP, KR, KZ, LA, LC, LK, LR, LS, LU, LY, MA, MD, ME, MG, MK, MN, MW, MX, MY, MZ, NA, NG, NI, NO, NZ, OM, PA, PE, PG, PH, PL, PT, QA, RO, RS, RU, RW, SA, SC, SD, SE, SG, SK, SL, SM, ST, SV, SY, TH, TJ, TM, TN, TR, TT, TZ, UA, UG, US, UZ, VC, VN, ZA, ZM, ZW.
- (84) Designated States (unless otherwise indicated, for every kind of regional protection available): ARIPO (BW, GH, GM, KE, LR, LS, MW, MZ, NA, RW, SD, SL, ST, SZ, TZ, UG, ZM, ZW), Eurasian (AM, AZ, BY, KG, KZ, RU, TJ, TM), European (AL, AT, BE, BG, CH, CY, CZ, DE, DK, EE, ES, FI, FR, GB, GR, HR, HU, IE, IS, IT, LT, LU, LV, MC, MK, MT, NL, NO, PL, PT, RO, RS, SE, SI, SK, SM, TR), OAPI (BF, BJ, CF, CG, CI, CM, GA, GN, GQ, GW, KM, ML, MR, NE, SN, TD, TG).

Published: — with international search report (Art. 21(3))

(54) Title: SELF-GUIDING CUTTING DEVICE

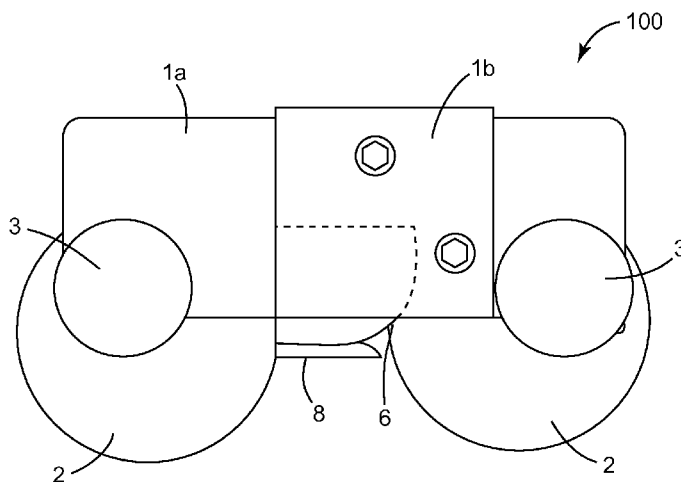

**FIG. 3A**

(57) Abstract: Self-guiding cutting tool (100) for cutting an adhesive film (20) applied to the roof panel (30) of a car, wherein the roof panel is connected to a side panel (31) of the car by a joint area (32) containing a welding ditch channel, said cutting tool (100) comprising a cutting device (6), at least one guiding means (2) guiding the cutting device (6) over the welding ditch channel of the joint area (32), and at least one transporting means (3) allowing the cutting device (6) to be moved over the welding ditch channel of the joint area (32). Also provided is a method of applying adhesive films to the roof panels of a car using the cutting tool.

WO 2015/116746 A1

## SELF-GUIDING CUTTING DEVICE

### Field

5 The invention relates to a self-guiding cutting device for cutting adhesive films applied to roof panels of cars.

### Background

10 Recently it has become very popular to use different colors on the bodywork of vehicles, for example, having a black color on the roof of a car while the remainder of the bodywork of the car has a different color. The application of different colors requires two subsequent lacquering processes. In the first step a first lacquer layer is applied to the entire bodywork of the vehicle. The first lacquer has to dry before the second lacquer layer can be applied onto the first lacquer layer to provide an area of different color. This operation takes time and increases the production costs. Therefore, there is a need for other methods to apply different colors to the bodywork of a vehicle.

15 It has been suggested to use appropriately colored polymeric films that can be adhesively attached to the respective portions of the bodywork of a vehicle. Attaching such films onto the roof of the car creates the visual impression of a uniformly continuous area between the car windows. The film may have a high-gloss finish to provide the impression of a continuous glass surface.

20 When applying adhesive films to the roof of cars the films may be cut into the desired shape after their application to the roof. In such case the lacquer layer of the roof may be damaged by the cutting. When using pre-cut films the precise positioning of the pre-cut films on the car roof is difficult under manufacturing conditions, in particular, in view of typical manufacturing tolerances.

25 Therefore, it has been an object of the present invention to provide a cutting tool and a corresponding method of cutting an adhesive polymer film being pre-attached to a car roof essentially without damaging the car roof when cutting the film. It has been another object of the present invention to provide a cutting tool that is easy to handle and that can be easily adapted to different car models. It has been still another object of the present invention to provide a cutting tool and a corresponding cutting method that can be reliably used under manufacturing conditions  
30 at reasonable costs.

### Summary

35 The above objects are met by the self-guiding cutting tool described herein. The cutting tool is suitable for cutting an adhesive film that has been applied to the roof panel of a car that contains a weld ditch channel. Cars are manufactured by assembling various components. Side panels and roof panels are prepared separately and then joint, typically by welding. The joint area between

side panel and roof panel is not even in many car types but contains a small raised area, or in most cases a lowered area, commonly referred to as “weld ditch channel”.

Therefore, in one aspect there is provided a self-guiding cutting tool (100) for cutting an adhesive film (20) applied to the roof panel (30) of a car, wherein the roof panel is connected to a side panel (31) of the car by a joint area (32) containing a welding ditch channel, said cutting tool (100) comprising a cutting device (6), at least one guiding means (2) guiding the cutting device (6) over the welding ditch channel of the joint area (32), and at least one transporting means (3) allowing the cutting device (6) to be moved over the welding ditch channel of the joint area (32), wherein the guiding means (2) is mechanical.

In another aspect there is provided a method of applying an adhesive film (20) to the roof panel (30) of a car wherein the roof panel is connected to a side panel (31) of the car by a joint area (32) containing a welding ditch channel, comprising the steps of

- attaching the adhesive film (20) to the roof panel (30) of the car without adhering the sections of the adhesive film (20) extending from the roof panel over the welding ditch channel towards the side panel;

- cutting off the non-adhered sections of the adhesive film by moving the cutting tool (100) according to any one of the preceding claims over the welding ditch channel.

#### Short description of the Figures

Fig. 1 is a schematic representation of the cutting of an adhesive film on a car roof by the cutting device of the cutting tool according to the present disclosure.

Fig.2 is schematic cross-sectional view of the cutting tool according to the present disclosure positioned on the joint area between side panel and roof panel of a car.

Fig. 3A is a schematic representation of the side view of an embodiment of a self-guiding cutting tool according to the present disclosure.

Fig. 3B is a detailed schematic view of a cutting knife and its protective housing of a cutting tool according to the present disclosure.

Fig. 3C is a schematic bottom view of a self-guiding cutting tool according to the present disclosure.

#### Detailed Description

The present invention provides a self-guiding cutting tool for cutting a polymeric film attached to the roof panel of a car.

The bodywork of a car comprises a front panel, a back panel, side panels and a roof panel. During manufacturing of the car the side panels and the roof panels are joined together applying various techniques such as resistance welding, laser stitch welding, laser welding and laser brazing. Depending on the design of the side panels and the roof panel, respectively, and the

joining technique used the joint areas can exhibit different shapes and geometries. In one embodiment, the side panel and the roof panel are arranged to form an overlap joint area that contains a ditch shaped welding line. This area is referred to as “roof ditch” or “welding roof ditch”. The two panels are joined, for example, by resistance welding resulting in seams running in the ditch joint areas between the respective side panel and the roof panel along both sides of the roof panel. Welding seams obtained by laser welding typically have a smoother surface than welding seams obtained by resistance welding so that laser welding is generally preferred.

When applying films to the roof of a car it is often desired to cut the film along the roof ditch. The self-guiding cutting tool of the present invention allows the films to be cut over the roof ditch or in areas in proximity thereof. The cutting tool contains a cutting device to cut the film. The cutting tool can be moved along the roof ditch by transportation means, for example wheels. The cutting tool may be configured such that the transportation means can be placed on the roof of the car. The position of the cutting device with respect to the roof ditch is controlled by the mechanical guiding means either alone or in combination with the transportation means. The guiding means may movably engage the cutting tool with a portion of the side panel and allow the cutting tool to be moved over the roof in a direction parallel to the side panel. Guiding means, transportation means and cutting device are configured on the cutting tool such that the cutting device is placed in a defined position, namely the position where the film is to be cut. Most conveniently the films can be cut over the roof ditch by the present cutting device.

To cut the films, typically, the films are adhered to the roof of the car and the sections of the film over the roof ditch and extending towards the side panel are not adhered to the roof and are lifted upwards. Lifting bars may be used to lift up the films. The cutting tool is then moved with its cutting device over the film along the line to be cut. This is exemplified in figure 1 to which is now referred. Figure 1 is a schematic cross-sectional representation of the joint area (32) between a side panel (31) and a roof panel (30) of a car. The joint area (32) represented in figure 1 is lower than its adjacent parts and forms a welding roof ditch. An adhesive polymeric film is placed over the roof panel and it is adhered to the roof panel (30) but is kept in a raised position over the joint area (32). The film is cut by the cutting device (6). The cutting device represented in figure 1 is shown together with a protective housing shielding the surface of the joint area (32) from being damaged by the cutting device (6). The cutting proceeds along a defined direction and is guided along that direction by the cutting tool containing guiding means and transportation means.

The configuration of the joint area shown in figure 1 is one where the raised area is on the side panel portion (31). However other configurations exist and the cutting tool can also be applied to such other configurations accordingly. For example the raised area may be on the roof panel side. There may also be two raised areas, one on the side panel part (31) and the other on the roof

panel part (30). The same cutting method is applied and the film is lifted at the areas where it is to be cut off.

The cutting tool will now be described in greater detail by referring to the figures. In figure 2 a cross-sectional view of the cutting device is shown positioned over the joint area between side panel and roof panel. The joint area shown in figure 2 is shaped as a roof ditch (32) extending to the roof panel, with a raised area on the side panel part (31). The opposite configuration of the joint area is also possible, for example a ditch shape where the raised area is not on the side panel part of the joint area but on the roof area. In that case the configuration of the cutting tool may be in reverse order to that shown in figure 2. The cutting tool (100) in figure 2 contains a body part (1) to which are attached a guiding means (2) and a transportation means (3). In a typical embodiment the guiding means (2) is a wheel, also other embodiments may also be used where the guiding means may be a rubber or plastic lip or a rail. The guiding means (2) is shaped such that it can movably engage the side panel (31) or a portion thereof. The engagement may be a simple contact. In the preferred embodiment where the guiding means (2) is a wheel, the wheel may be angular as shown in figure 2, or it may have added thereto a protrusion. In figure 2 the guiding wheel (2) has an angular portion adapted to the shape of the side panel. The angular portion of the wheel (2) is such that the inner side of the wheel facing the cutting tool body (1) or the side panel (31) has a smaller diameter than the opposite side, i.e. the side facing away from the side panel. Opposite to the guiding means (2) in figure 2 is the transportation means (3). Most conveniently the transportation means is also a wheel. The transportation wheel (3) may be placed on the roof panel. In the particular embodiment shown in figure 2, the transportation wheel (3) is of angular shape. It is shaped to engage the raised part of the roof ditch (32). This is achieved by an angular shape of the wheel where one side of the wheel has a smaller diameter than its opposite side, or, for example, by adding a protrusion to the wheel protruding into the ditch. In the embodiment shown in figure 2 the inner side of the transportation wheel (3) facing the side panel has a smaller diameter than its opposite side facing the roof panel, which in the embodiment shown in figure 2 is achieved by the protrusion on wheel (3). The cutting tool when placed over the roof ditch is now held in place over the ditch by guiding wheel (2) and transportation wheel (3) and can be rolled along the roof ditch in a direction from front to rear of the car or vice versa. The transportation wheel (3) does not have to be of angular shape as shown in figure 2. It may be a regular wheel and can simply be placed on a flat surface of the roof panel. The support provided by the guidance wheel (2) may be sufficient to guide the cutting tool over the joint area and control the position of the cutting device. Typically, the guidance wheel (2) which is placed on a portion of the side panel has a bigger diameter than the transportation wheel (3) as is also shown in figure 2.

The guidance and transportation means for the cutting tools according to the present disclosure are made of a material that is not damaging to lacquered surfaces. Typically,

transportation means and guidance means are made of an elastic or flexible material, such as rubber or plastics, like polyamides.

In a preferred embodiment the cutting device contains at least two guidance means (2) and/or at least two transportation means (3), preferably both guiding and transportation means  
5 being wheels. Such an embodiment is represented in figure 3A.

Figure 3A shows a schematic side view of a cutting carriage (100). It contains two transportation means (transportation wheels (3)). Opposite the transportation wheels (3) are the guidance wheels (2). According to the present disclosure, the transportation wheels and guidance wheels may be on the same axis or may be on different ones and may also be independently  
10 connected to the cutting tool. At least the transportation wheels are rotatably mounted to the body of the cutting tool. Preferably, also the guidance wheels are rotatably mounted to the body of the cutting tool. In the embodiment shown in figure 3A the cutting tool contains a body part (1a) to which the wheels are rotatably mounted by two axes.

The cutting tools according to the present disclosure contain at least one cutting device.

In the embodiment represented in figure 3A the cutting device (6) is contained in housing  
15 (1b) attached to the body part (1a) of the cutting tool. Any cutting device suitable for cutting polymeric films may be used as cutting devices according to the present disclosure. Typical examples include fixed knives and rotating blades. The cutting device may be mechanically driven or electronically. It may be controlled remotely. The cutting device may be connected to a lifting  
20 device, which raised the film to be cut. Cooling devices may be present to cool the cutting device. The cutting device may be positioned where suitable. For example the cutting device may be positioned between guiding means and transportation means or the transportation means may be positioned between cutting device and guiding device. The cutting device may be in a separate housing that can be positioned variably with respect to the body of the cutting tool. This way the  
25 cutting tool can be applied to different geometries.

The cutting device may be partially surrounded by a protective housing to avoid the cutting device contacting the surface of the car and prevent damage to the car during the cutting operation. In figure 3A a protective housing (8) is shown. The protective housing (8) may contain a groove in which the knife or a rotating blade runs during the cutting operation providing additional stability  
30 to the knife or rotating blade. The cutting device exemplified in figure 3A is a rotating blade which runs in a groove of the protective housing (8) as is shown in figures 3B and 3C.

Transportation means, guidance means and cutting device may be provided adjustably. This way the cutting tool could be applied to different car models and the distance between transportation means and guidance means can be adjusted as needed. Also the cutting device may  
35 be connected to the body of the cutting tool such that it can be placed in various positions.

The cutting device may be a carriage for manual use but may also be part of an automated unit and driven electronically. For example, the cutting tool according the present disclosure may be part of an assembly line. Such an assembly line may comprise an assembled car containing a roof panel (30) and a side panel (31) joined to each other to form a joint area (32) containing a welding ditch channel, an unit to apply an adhesive film (20) to the roof panel and a self-guided cutting tool (100) according to the present disclosure.

The cutting tool may be suitable to cut films that are used to provide protective coatings or coloring or other decoration to cars. Such films are typically adhesive films, containing one or more polymer layers and at least one adhesive layer. Typically, the adhesive layer is a pressure-sensitive adhesive. This means the adhesive can be applied to the substrate to provide an adhesive bond without requiring increased temperatures and is simply applied by pressure. Typical adhesives are acrylate-based adhesive, preferably solvent-free adhesives. Typical polymer layers include polyvinylchloride, polyurethanes, polyolefine polymers and combinations thereof. Such films are commercially available, for example under the trade designation SCOTHCAL from 3M Company.

#### Example 1

A roll of Scotchcal® film commercially available from 3M Co was inserted into a guiding bar. Then a piece of the Scotchcal® film having a sufficient length to cover the roof panel of a SKODA FABIA car was dewound from the roll, inserted into an application frame and cut off. The release liner was removed from the Scotchcal® film and the film was placed over the roof panel of the car, lowered onto the roof and adhered to the surface of the roof panel. The portions of the Scotchcal® film adjacent to the edges of the roof panel of the car were not adhered to the roof panel. Then the self-guided cutting tool as shown in figures 3A -3C was placed over the roof ditch with the guidance wheels placed on the side panel of the car and moved in front to rear direction along the side panel over the roof ditch to cut the unadhered Scotchcal® film off.

## CLAIMS

1. Self-guiding cutting tool (100) for cutting an adhesive film (20) applied to the roof panel (30) of a car, wherein the roof panel is connected to a side panel (31) of the car by a joint area (32) containing a welding ditch channel, said cutting tool (100) comprising a cutting device (6), at least one guiding means (2) guiding the cutting device (6) over the welding ditch channel of the joint area (32), and at least one transporting means (3) allowing the cutting device (6) to be moved over the welding ditch channel of the joint area (32), wherein the guiding means (2) is mechanical.
2. The self guiding cutting tool (100) of claim 1 wherein the transportation means (3) is a wheel.
3. The self-guiding cutting tool (100) according to any one of the preceding claims comprising at least two transportation means (3).
4. The self-guiding cutting tool (100) of any one of the preceding claims, wherein the guiding means (2) is a wheel configured to engage with a portion of the side panel (31) and allow movement of the cutting tool (100) along the side panel in a direction from the front part to the rear part of the car or vice versa.
5. The self-guiding cutting tool (100) according to any one of the preceding claims comprising at least two guiding means (2).
6. The self-guiding cutting tool (100) according to any one of the preceding claims wherein the cutting device (6) is positioned between the guiding means (2) and the transportation means (3).
7. The self-guiding cutting tool (100) according to anyone of the preceding claims wherein the transportation means (3) is positioned between cutting device (6) and the guiding means (2).
8. The self-guiding cutting tool (100) according to anyone of the preceding claims, wherein the cutting device (6) contains a cutting blade selected from a fixed blade or a rotating blade.
9. The self-guiding cutting tool (100) according to any one of the preceding claims further comprising a protective housing (9) surrounding the bottom part of the cutting device (6) to prevent the cutting device (6) from contacting the roof panel (30) when being moved over the roof ditch channel (32).

10. The self-guiding cutting tool (100) according to any one of the preceding claims wherein the guiding means is a wheel (2) and wherein the wheel contains an angular portion such that the side facing the cutting tool (100) has a smaller diameter than the side opposite thereto.

5

11. The self-guiding cutting tool (100) according to any one of the preceding claims wherein the transportation means (3) is a wheel that is spaced and configured such that it engages with a raised area of the weld ditch channel (32).

10 12. The self guiding cutting tool (100) wherein the guiding means (2) and the transportation means (3) are wheels that are configured and positioned such that the guiding means (2) engages with a portion of the side panel (31) and the transportation means (3) engages with a raised area of the weld ditch channel (32).

15 13. The self guiding cutting tool (100) wherein the transportation means (3) is a wheel containing an angular portion such that the side of the wheel facing the cutting tool (100) has a different diameter than the side opposite thereto.

20 14. An assembly line comprising an assembled car containing a roof panel (30) and a side panel (31) joined to each other to form a joint area (32) containing a welding ditch channel, an unit to apply an adhesive film (20) to the roof panel and a self-guided cutting tool (100) according to any one of claims 1 to 13.

25 15. Method of applying an adhesive film (20) to the roof panel (30) of a car wherein the roof panel is connected to a side panel (31) of the car by a joint area (32) containing a welding ditch channel, comprising the steps of

- attaching the adhesive film (20) to the roof panel (30) of the car without adhering the sections of the adhesive film (20) extending from the roof panel over the welding ditch channel towards the side panel;
- 30 - cutting off the non-adhered sections of the adhesive film by moving the cutting tool (100) according to any one of the preceding claims over the welding ditch channel.

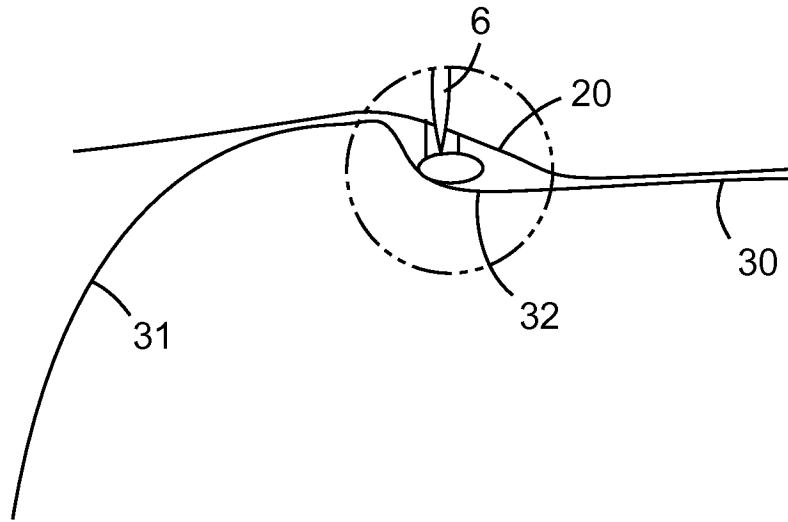

**FIG. 1**

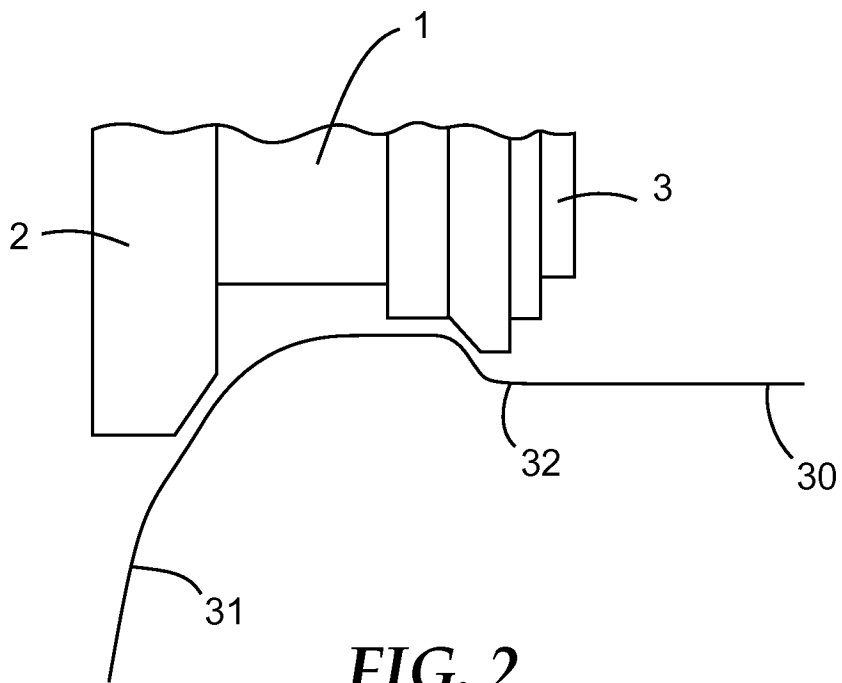

**FIG. 2**

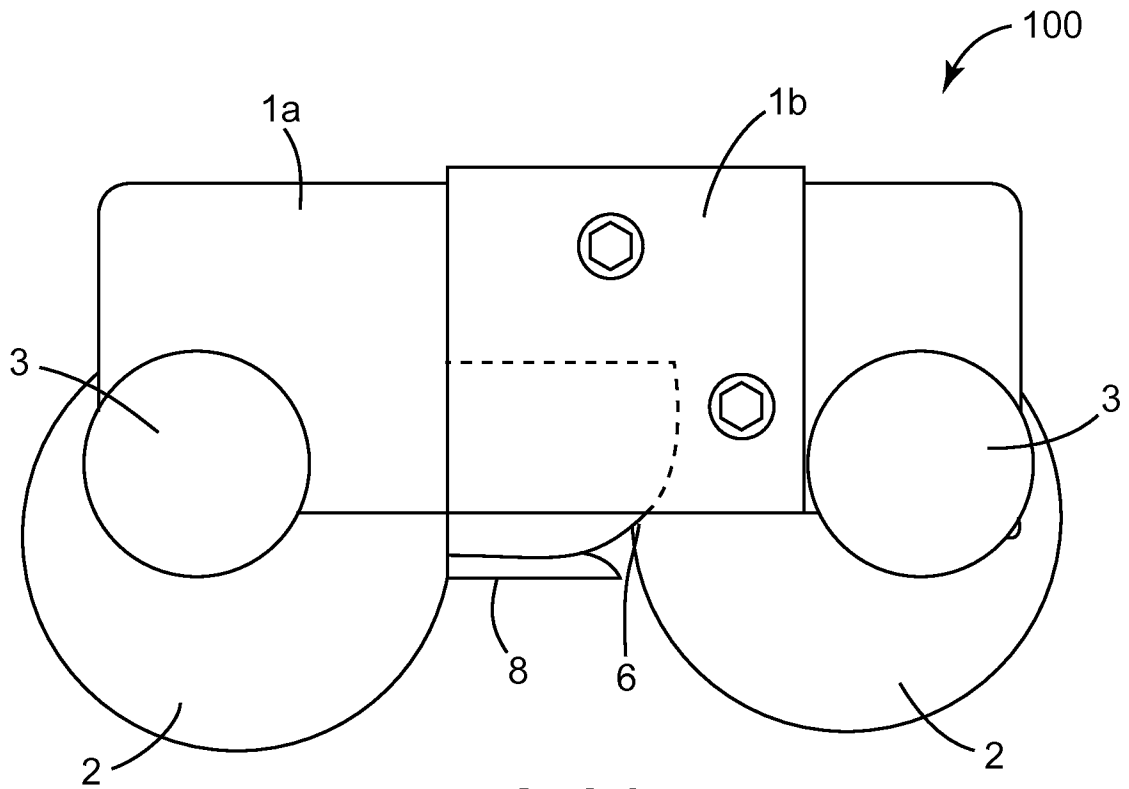

**FIG. 3A**

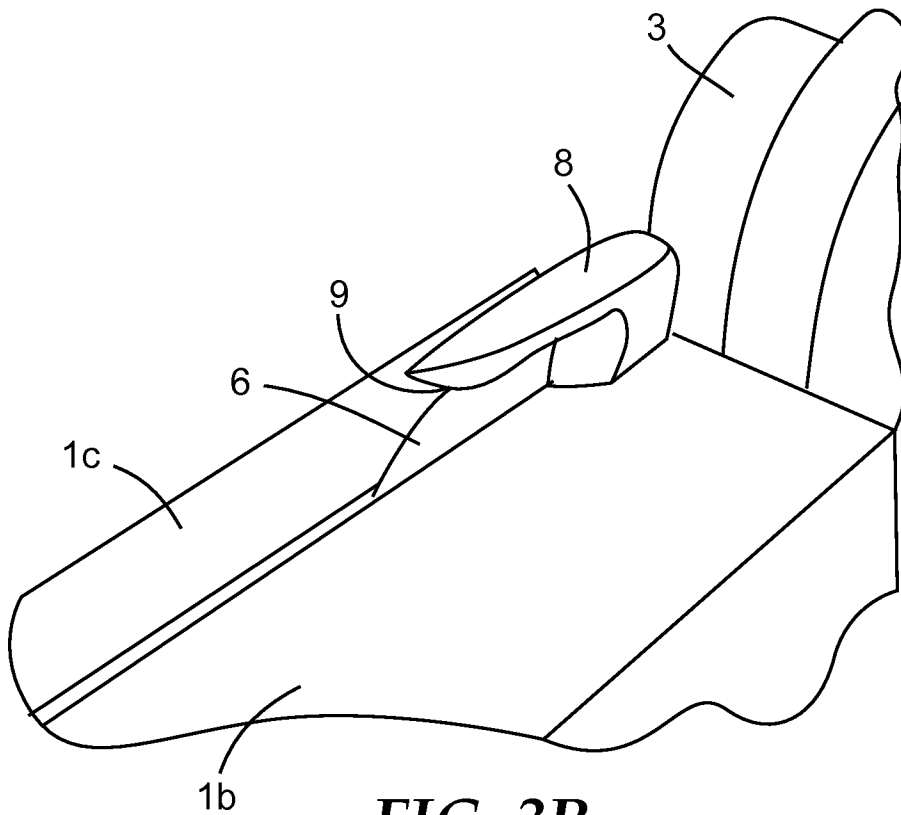

**FIG. 3B**

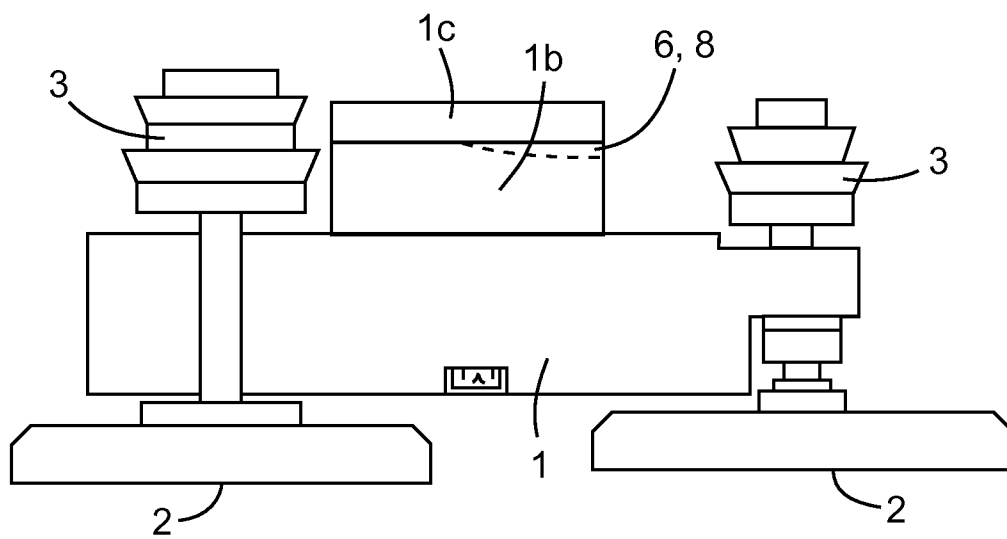

**FIG. 3C**

**INTERNATIONAL SEARCH REPORT**

International application No  
PCT/US2015/013397

**A. CLASSIFICATION OF SUBJECT MATTER**  
INV. B26D7/00  
ADD.  
  
According to International Patent Classification (IPC) or to both national classification and IPC

**B. FIELDS SEARCHED**  
Minimum documentation searched (classification system followed by classification symbols)  
B26D B26B

Documentation searched other than minimum documentation to the extent that such documents are included in the fields searched

Electronic data base consulted during the international search (name of data base and, where practicable, search terms used)  
EPO-Internal, WPI Data

**C. DOCUMENTS CONSIDERED TO BE RELEVANT**

Category*	Citation of document, with indication, where appropriate, of the relevant passages	Relevant to claim No.
X	US 1 776 046 A (SCHMIDT EDWIN T) 16 September 1930 (1930-09-16) figures 1-4	1-15
X	----- US 8 495 818 B1 (PEPPETT ROBERT ANTHONY [CZ]) 30 July 2013 (2013-07-30) figures 1,2	1-9
A	----- WO 2008/014546 A1 (RAYNER DESIGN PTY LTD [AU]; RAYNER WILLIAM [AU]) 7 February 2008 (2008-02-07) the whole document	10-15
X	----- WO 2008/014546 A1 (RAYNER DESIGN PTY LTD [AU]; RAYNER WILLIAM [AU]) 7 February 2008 (2008-02-07) the whole document	1-9
A	----- the whole document	10-15

Further documents are listed in the continuation of Box C.

See patent family annex.

\* Special categories of cited documents :

- "A" document defining the general state of the art which is not considered to be of particular relevance
- "E" earlier application or patent but published on or after the international filing date
- "L" document which may throw doubts on priority claim(s) or which is cited to establish the publication date of another citation or other special reason (as specified)
- "O" document referring to an oral disclosure, use, exhibition or other means
- "P" document published prior to the international filing date but later than the priority date claimed

- "T" later document published after the international filing date or priority date and not in conflict with the application but cited to understand the principle or theory underlying the invention
- "X" document of particular relevance; the claimed invention cannot be considered novel or cannot be considered to involve an inventive step when the document is taken alone
- "Y" document of particular relevance; the claimed invention cannot be considered to involve an inventive step when the document is combined with one or more other such documents, such combination being obvious to a person skilled in the art
- "&" document member of the same patent family

Date of the actual completion of the international search  
  
20 March 2015

Date of mailing of the international search report  
  
30/03/2015

Name and mailing address of the ISA/  
European Patent Office, P.B. 5818 Patentlaan 2  
NL - 2280 HV Rijswijk  
Tel. (+31-70) 340-2040,  
Fax: (+31-70) 340-3016

Authorized officer  
  
Wimmer, Martin

# INTERNATIONAL SEARCH REPORT

Information on patent family members

International application No

PCT/US2015/013397

Patent document cited in search report	Publication date	Patent family member(s)	Publication date
US 1776046	A	16-09-1930	NONE
-----			
US 8495818	B1	30-07-2013	NONE
-----			
WO 2008014546	A1	07-02-2008	AU 2007281020 A1 07-02-2008
			EP 2112965 A1 04-11-2009
			US 2009320664 A1 31-12-2009
			WO 2008014546 A1 07-02-2008
-----			