

P. HAHN.
 YARN MERCERIZING MACHINE.
 APPLICATION FILED AUG. 16, 1910.

998,288.

Patented July 18, 1911.

8 SHEETS—SHEET 1.

Fig. 1

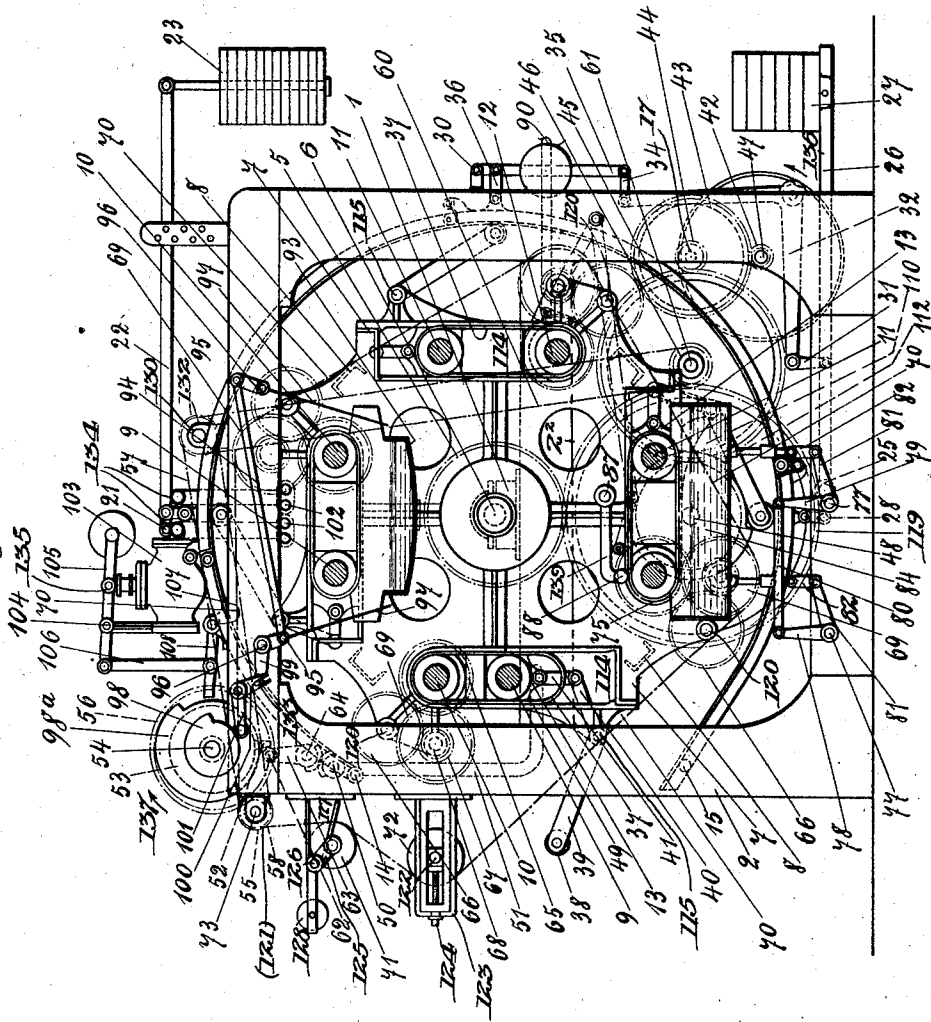

Witnesses:

Nikolai Meinen
Carl Hagen

Inventor

Paul Hahn

P. HAHN.
 YARN MERCERIZING MACHINE.
 APPLICATION FILED AUG. 15, 1910

998,288.

Patented July 18, 1911.

3 SHEETS—SHEET 2.

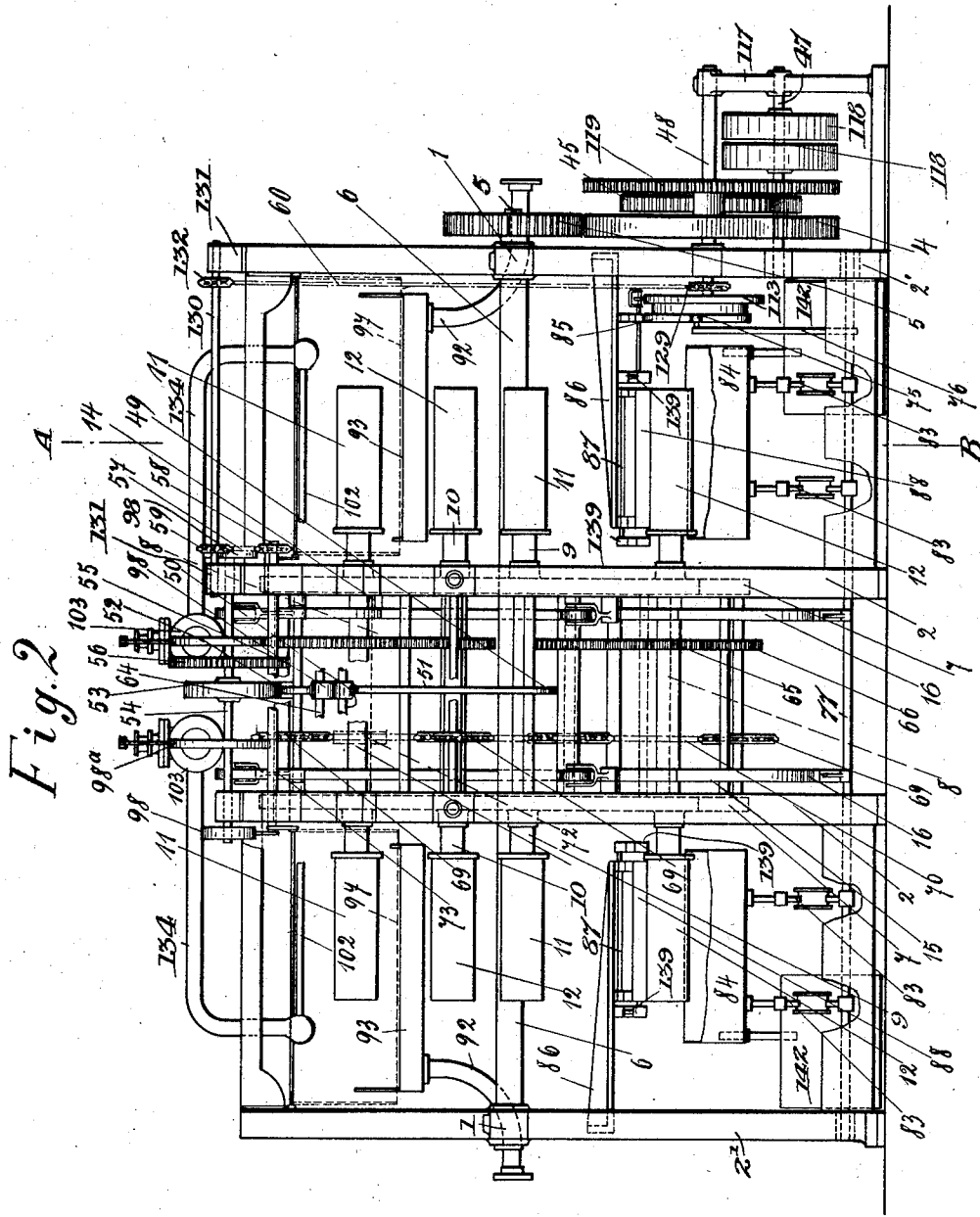

Fig. 2

Witnesses:
Antonius Meuser
Carl Heig

Inventor:
Paul Hahn

P. HAHN.
 YARN MERCERIZING MACHINE.
 APPLICATION FILED AUG. 16, 1910.

998,288.

Patented July 18, 1911.

3 SHEETS—SHEET 3.

Fig. 3

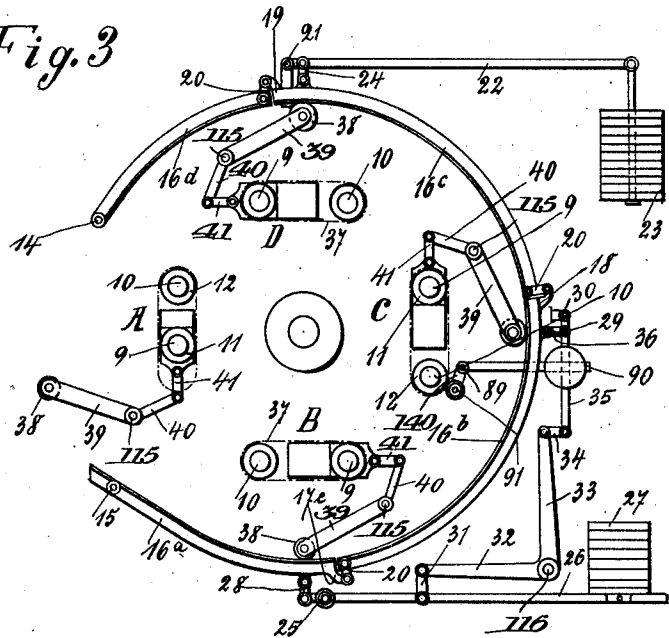
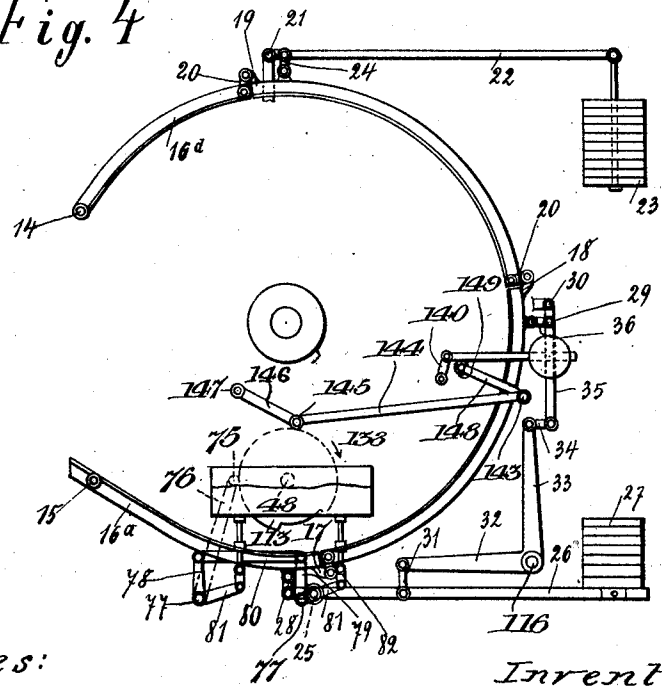

Fig. 4



Witnesses:
 Nikolai Meier
 Carl Meyer

Inventor:
 Paul Hahn

UNITED STATES PATENT OFFICE.

PAUL HAHN, OF NIEDERLAHNSTEIN, GERMANY.

YARN-MERCERIZING MACHINE.

998,288.

Specification of Letters Patent. Patented July 18, 1911.

Application filed August 15, 1910. Serial No. 578,062.

To all whom it may concern:

Be it known that I, PAUL HAHN, a citizen of the Empire of Germany, residing at Niederlahnstein-on-the-Rhine, in the Empire of Germany, have invented a new and useful Yarn-Mercerizing Machine, of which the following is a specification.

In my U. S. Patent No. 755,765 of March 29, 1904, I have shown and described a yarn mercerizing machine.

My present invention relates to improvements in such machines, whereby the output of the machine is considerably increased.

A revolver, that is to say a frame turnable around a central axis is disposed and is adapted to carry on one or both sides several pairs of rollers, the rollers of each pair being capable of being approached and moved away from one another. A driving gear is disposed for periodically turning the revolver through a certain angle and stopping it, so that each pair of rollers on either side of the frame can be consecutively brought into several positions, before it returns to the initial position. In the initial position the two rollers of any pair are brought nearer together and are ready for receiving a hank of yarn, and before the following turn of the revolver the two rollers of the pair are again moved away for preliminarily tightening the hank of yarn. In the following several positions of the same pair of rollers the impregnation, the squeezing, the rinsing, and if so desired the repeated squeezing of the yarn can take place consecutively, while the yarn is constantly tightened. On the pair of rollers returning to the initial position, the two rollers are again brought nearer together, so that the treated hank of yarn can be exchanged for a fresh hank of yarn. Means are provided for constantly driving the several pairs of rollers excepting those which occupy their initial position, so that the hanks of yarn can be easily put on and are afterward constantly moved while being treated, whereupon they are again stopped in the initial position of the revolver and can be easily taken off.

I will now proceed to describe my inven-

tion with reference to the accompanying drawings, in which—

Figure 1 is a vertical cross section through the improved yarn mercerizing machine on the line A—B in Fig. 2, Fig. 2 is a front elevation of the same, parts of the two lower tanks being broken away, Fig. 3 is a diagram showing certain parts alone out of Fig. 1, and Fig. 4 is a similar diagram, which shows other parts out of Fig. 1.

Similar characters of reference refer to similar parts throughout the several views.

The two outer standards 2¹, 2² have each a horizontal cross beam 2³ with a central bearing 1, and in the two bearings 1, 1 a horizontal revolver shaft 6 is mounted to turn. Fastened on this shaft 6 are two parallel shields 7, 7, which are shown to be connected together by four cross bars 8, 8 and to carry in suitable bearings four shafts 10, 10, while four other shafts 9, 9 are mounted to turn in movable bearings 13, 13, which slide in straight guides 114, 114 provided in the two shields 7, 7. Without the two shields 7, 7 the shafts 10, 10 carry on both sides rollers 12, 12 and the shafts 9, 9 the rollers 11, 11. In the two shields 7, 7 four shafts 115, 115 are mounted to turn, on which bell-crank levers 39, 40 are fastened. The short arms 40, 40 of these levers are pivotally connected with the movable bearings 13, 13 by means of links 41, 41. The long arms 39, 39 of the said levers carry at their free ends rollers 38, 38, which are adapted to roll on the inside of two parallel races 16, 16 of the following construction. Each race 16 comprises four parts 16^a, 16^b, 16^c and 16^d (Figs. 3 and 4) forming an arc of about 270°, the outer parts 16^a and 16^d being only partly curved, so that their straight portions form tangents to the circle concentric with the revolver shaft 6.

The four parts 16^a, 16^b, 16^c and 16^d of each race 16 are pivotally and indirectly connected with one another by radially disposed links 20, 20 and projections 17, 18, 19 made in one with the parts 16^a, 16^b, 16^c respectively. The free ends of the outer parts 16^a and 16^d are mounted to rock on pins 15 and 14 respectively, which are fastened on

the neighboring standard 2. The latter carries in any known manner a pin 21 above on which a weight-lever 22 is mounted to rock. This lever 22 is near the pin 21 pivotally connected with the upper inner race part 16^c by means of a radially disposed link 24. On each inner standard 2 a pin 25 is provided below, on which a two-armed weight-lever 26 is mounted to rock. The short arm of the latter is pivotally connected with the lower outer race part 16^a by means of a radially disposed link 28. The long arm of the lever 26 is pivotally connected by a link 31 with one arm 32 of a bell-crank lever 32, 33 rocking on a pin 116 provided on the standard 2. The latter carries a pin 30, on which a vertical lever 35 is mounted to rock. This lever 35 is pivotally connected at its free end by a link 34 with the arm 33 and near its fulcrum 30 at 29 by a radially disposed link 36 with the lower inner race part 16^b. The several parts 16^a, 16^b, 16^c, 16^d of each race 16 are so adjusted, that their ends bear on one another under the action of the weights 23 and 27 for the maximum distance of the two rollers 11 and 12 in each pair. The two rollers 11 and 12 of each pair are adapted to receive a hank of yarn 37 put over them, in which case their distance will be a little shorter than the said maximum distance on the yarn being stretched. The consequence of this will be that the roller 38 on the respective bell-crank lever 39, 40 bearing on the respective part of the race 16 will move the latter a little outward, which means, that small spaces will be formed between the ends of the several race parts 16^a, 16^b, 16^c, 16^d. The weights 23 and 27 consist each of detachable plates and it will be understood, that by reducing or increasing the number of plates the pressure of the weights 23, 27 on the race parts 16^a, 16^b, 16^c, 16^d can be varied and consequently the strain on the hanks of yarn 37, 37 can be diminished or increased, as may be required.

In the right outer standard 2¹ and in a low standard 117 in Fig. 2 four shafts 47, 17, 61 and 48 are mounted to turn, of which the shaft 47 carries two driving pulleys 118 (one fast and one loose) and a pinion 42. The pulleys 118 are to be driven in the direction of the arrow 136 in Fig. 1. The shaft 17 has fastened on it a gear wheel 43 meshing with the pinion 42 and a pinion 44, which latter meshes with a gear wheel 45 fastened on the shaft 61. On the latter are fastened a pinion 46 and a sprocket wheel 129. The pinion 46 meshes with a gear wheel 119 fastened on the shaft 48, which latter carries a wheel 4 provided with gear teeth on a short portion of its periphery only. A gear wheel 5 is fastened on the revolver shaft 6 mentioned above and can

periodically mesh with the toothed part of the wheel 4. The latter is adapted to turn the gear wheel 5 and thereby the revolver (that is the shaft 6 with the two shields 7, 7 and the various parts carried by the latter) each time through an angle of 90°, whereupon the revolver stops while the wheel 4 is constantly driven from the driving pulley 118. The gearing described so far is so proportioned, that the revolver can be turned consecutively into four different positions, in each of which two opposite pairs of rollers 11 and 12 on either side of the two inner standards 2, 2 are placed vertically and the two other pairs of rollers 11 and 12 horizontally, as is shown at Figs. 1 and 3. On the left side of the standard 2 in Fig. 2 the shaft 48 carries two cam disks 85 and 113 to be mentioned later on. Preferably the machine, that is the gearing, is so arranged, that each stoppage of the revolver shall last about four times as long as the period, during which the revolver is turned through an angle of 90°.

The four shafts 10, 10 of the revolver carry each a gear wheel 65 fastened on it, which meshes with a like gear wheel 66 keyed upon a shaft 120 that is mounted in the two shields 7, 7 to turn. The gear wheel 66 meshes with a pinion 67 fastened on a shaft 68, which has fastened on it a chain wheel 69. There are in all four sets of gear wheels 65, 66, 67 and four chain wheels 69, 69 on the revolver. An endless chain 70 passes over three of the four chain wheels 69, 69 and is prevented from engaging in the fourth chain wheel 69 by three chain wheels 71, 72 and 121. The chain wheel 72 which serves for tightening the endless chain 70, is fastened on a shaft 122, which turns in two movable bearings guided in two horizontal brackets 123 and therein adjusted by means of screw-spindles 124. The chain wheel 71 is fastened on a short shaft, which turns in the free ends of two arms 125 (Fig. 1) fastened on a shaft 126, that rocks in two brackets 127 provided on the two inner standards 2, 2 and carries on a third arm a weight 128. It will be understood, that the weight 128 prevents the strain in the endless chain 70 from exceeding a predetermined limit. The chain wheel 121 mentioned above is in Fig. 1 assumed to be hidden by a sprocket wheel 58 fastened on its shaft 73. The sprocket wheel 58 is connected by an endless chain 57 with a sprocket wheel 59, which is keyed upon a shaft 130 turning in two suitable bearings 131, 131 on two standards 2, 2¹. The shaft 130 has fastened on it a second sprocket wheel 132, which is connected with the above mentioned sprocket wheel 129 by an endless chain 60. It will be seen, that in this manner the endless chain 70 is put into constant motion from the driv-

ing pulley 118, so that it drives three of the four chain wheels 69, 69, while the fourth chain wheel 69 (on the left in Fig. 1) stops. It is also obvious, that during the periodical turns of the revolver three of the chain wheels 69 remain in engagement with the endless chain 70, until shortly before the end of the turn the uppermost chain wheel 69 comes out of engagement with the chain 70, while the fourth chain wheel 69 on the left in Fig. 1 which so far had stopped now engages below in the endless chain 70. The weight 128 in combination with its arm, the two arms 125 and the rocking chain wheel 71 permits the revolver to freely turn while its chain wheels 69, 69 engage the endless chain 70 at shifting points.

The above mentioned shaft 73 has keyed upon it a pinion 55, which meshes with a gear wheel 56 fastened on a shaft 54 that turns in suitable bearings on the two inner standards 2, 2 and in the direction of the arrow 137 in Fig. 1. The shaft 54 has fastened on it a cam disk 53 in its middle (Fig. 2), two cam disks 98 at its ends and two further cam disks 98^a, 98^a. The cam disk 53 has a single projecting cam or lug 52 and is otherwise cylindrical. The lug 52 can strike a roller 62 provided at the free end of an arm 63, which is keyed upon a shaft 64 rocking in the two inner standards 2, 2 and is made in one with a small toothed segment below. This toothed segment meshes with a like toothed segment fastened on a shaft 50 which is parallel to the one 64 mentioned and rocks in the two inner standards 2, 2. The said lower toothed segment is made in one with a long bent arm 51, 49, which normally occupies the position shown at Fig. 1, so that its one portion 51 is vertical and its other portion 49 is horizontal and engages in the path of any shaft 9. It will be understood, that during any turn of the revolver the next shaft 9 then above on the left in Fig. 1 will strike the horizontal portion 49 of the arm 49, 51, so that it will be thereby raised together with its two rollers 11, 11, whereby its distance from the other shaft 10 in the pair is shortened, as is shown at Figs. 1 and 3. Then it will be possible to take off the two hanks of yarn 37 meantime treated from the two pairs of rollers 11, 12 on both sides of the inner standards 2, 2 (Fig. 2) and to replace them by two fresh hanks of yarn. When the lug 52 on the cam disk 53 strikes the roller 62 and pushes it outward, then by means of the two said toothed segments the bent arm 49, 51 will be turned outward and thus withdrawn from the path of the shaft 9, so that the latter now released will drop together with its two rollers 11, 11, whereby the two fresh hanks of yarn 37 are preliminarily stretched. In consequence of this the two bell-crank

levers 39, 40 on the left in Fig. 3 will be turned, so that their rollers 38 will during the following turn of the revolver strike the two outer race parts 16^a at some distance before the points, where their straight portions run into their curved portions, and will be afterward moved a little inward, that is toward the revolver shaft 6 for straining the two hanks of yarn 37.

Two troughs 93, 93 are disposed above on both sides of the two inner standards 2, 2 between them and the two outer standards 2¹, 2¹. Each of them is provided with a curved discharge tube 92 leading to without the machine. The troughs 93, 93 are so located in the frame, that the rollers 11, 12 of all eight pairs can move over them without striking them. Two rocking splash plates 97, 97 are provided for each trough 93 and are adapted to rock about pivots 96, 96 turnable in the standards 2, 2¹. They are so connected together by a connecting rod 94 as to move in opposite directions on one of them being actuated by its arm 99. The free end of this arm 99 carries a pin, which engages in the slot at the free end of an arm 133 of a bell-crank lever 101 rocking on a suitable pin at the standard 2. The free end of the other arm 101 carries a roller adapted to roll on the periphery of the corresponding cam disk 98 mentioned above. This cam disk 98 is about for one half concentric with the shaft 54 and for the other half eccentric, a radial step connecting the highest point of the eccentric portion with the concentric portion. As long as the roller on the arm 101 rolls on the concentric portion of the cam disk 98, the two splash plates 97, 97 are to occupy their normal inclined position shown at Fig. 1, so that they are adapted to catch any splashing liquid and to conduct it downward into the trough 93. When, however, the roller on the arm 101 rolls on the eccentric part of the cam disk 98, the two splash plates 97, 97 are to be thereby turned outward into such a position, in which they permit the two rollers 11 and 12 of the then uppermost pair to move from their position shown into the next following position on the left in Fig. 1 and at the same time they permit the two rollers 11 and 12 of the following pair on the right in Fig. 1 to move from their position shown into the uppermost position.

Two valve boxes 103, 103 of any known construction are shown to be provided for supplying the rinsing liquid. They are to be connected together in any known manner and with the respective source by a pipe (not shown). Each valve box 103 is shown to be connected with four parallel horizontal perforated pipes 102 above the then uppermost hank of yarn 37 by means of two parallel bent pipes 134. The valve

proper of each valve box 103 is connected with a vertical spindle 135 guided in any known manner in the stuffing-box and pivotally connected with a weighted lever 105, which rocks on a pin 104 in a suitable support at the valve box 103. The rear arm of the weighted lever 105 is pivotally connected by a link 106 with a lever 108 rocking on a pin 107 at the standard 2. The corresponding cam disk 98^a is similar to that 98, only that it is larger, and its radial step is adapted to strike and depress the lever 108, whereby the weighted lever 105 is raised to open the valve proper and to permit the rinsing liquid to flow through the perforations of the pipes 102, 102 on the hank of yarn 37.

Two movable alkali tanks 84, 84 are provided below on both sides of the inner standards 2, 2 between them and the outer standards 2¹, 2¹. They are each on the underside provided with four vertical rods 83, 83, which are guided in suitable supports of any known construction (not shown). The lower ends of the rods 83, 83 are pivotally connected by means of links 82, 82 with arms 81, 81 fastened on two parallel shafts 77, 77, which extend from one outer standard 2¹ through the inner standards 2, 2 to the other outer standard 2¹ and are therein mounted to rock. The two shafts 77, 77 are coupled together by means of arms 78, 79 and connecting rods 80 (Fig. 4), so that it is sufficient to turn one of them by means of a lever 76 in either direction for simultaneously raising and lowering the two alkali tanks 84, 84. The free end of the lever 76 carries a roller 75, which is adapted to roll on the periphery of the already mentioned cam disk 85. The latter should be so shaped as to periodically raise the two alkali tanks 84, 84 during each stoppage of the revolver and to lower them before the turn of the latter, the shaft 48 running in the direction of the arrow 138 in Fig. 4.

Two brackets 86, 86 (Fig. 2) are provided on the inside of the outer standards 2¹, 2¹ and have each suitable bearings, in which a horizontal shaft 87 is mounted to rock. On each shaft 87 two arms 139 with curved free ends are fastened for carrying a squeezing roller 88, which is adapted to bear on the hank of yarn 37 above the lowermost roller 12 for squeezing the alkali out of the yarn. In a similar manner (not shown) two shafts 89, see Figs. 3 and 4, in the common axis are mounted to rock in the frame and have each two arms 140 fastened on it for carrying a squeezing roller 91, which is adapted to bear on the hank of yarn 37 on the right roller 12 in Fig. 3 for squeezing the alkali out of the yarn. The liquid squeezed out may be caught in any known manner, for example by means of a hopper, and conducted to some receptacle 142. A weighted lever 90 fastened

on each shaft 89 serves for pressing the roller 91 against the hank of yarn. In order to prevent the squeezing rollers 88, 88 and 91 from damaging the hanks of yarn 37, 37 during the change of the revolver from one position to the other one, they require to be withdrawn, which is effected by means of the cam disk 113 as follows. A shaft 143 (Fig. 4) is mounted in the two outer standards 2¹, 2¹ to rock and carries a long arm 144, which carries a roller 145 that is adapted to roll on the periphery of the cam disk 113. The arm 144 is made in one with a bent extension 146, which extends beneath one arm 139 (on the right in Fig. 2) and carries a roller 147 adapted to bear against the arm 139 from below. Another arm as long as 144, 146, but straight is fastened on the shaft 143 and extends beneath the extreme left arm 139 in Fig. 2 and carries a roller (similar to 147) adapted to bear against the said arm 139 from below. Two short arms 148 are fastened on the shaft 143 and extend beneath the weighted levers 90 and carry rollers 149 adapted to bear against them from below. It will be understood, that on the cam disk 113 raising the roller 145 also the rollers 147 will raise the squeezing rollers 88 off from the hanks of yarn 37 and the rollers 149 will raise the weighted levers 90 for turning the squeezing rollers 91 outward, that is off from the hanks of yarn 37.

The yarn mercerizing machine operates as follows: When the machine is started by shifting the driving belt (not shown) to the fast pulley 118 and the revolver is assumed to be stopped as shown, then two fresh hanks of yarn 37 are put on the two pairs of rollers 12, 11 in their initial position on the left in Figs. 1 and 3. Shortly afterward the bent arm 51, 49 is turned outward for releasing the shaft 9, so that the movable rollers 11, 11 dropping will preliminarily tighten the hanks of yarn 37, the two alkali tanks 84, 84 are lowered in the manner described and thereupon the toothed portion on the wheel 4 will engage in the teeth of the gear wheel 5 for turning the revolver through an angle of 90°, so that the two pairs of rollers 12, 11 will come into the lowermost position. Then the two alkali tanks 84, 84 are raised, so that the rollers 12, 11 with the hanks of yarn meanwhile put into motion will dip in the alkali for saturating the yarn with alkali. The squeezing rollers 88, which in the meantime had been raised, then lowered, will squeeze the alkali out of the upper part of the hanks of yarn 37. In this manner the moving yarn is treated, while two fresh hanks of yarn are put on the two following rollers 12, 11 now occupying their initial position on the left in Fig. 1. Then the two alkali tanks 84, 84 are again lowered, the squeezing rollers 88 are raised and the squeezing roll-

ers 91, 91 are moved outward, whereupon in the manner described the revolver is turned through another angle of 90°, so that the two first pairs of rollers 12, 11 now occupy the position on the right in Fig. 1, while the next following two pairs of rollers 12, 11 are shifted from their initial position to the lowermost position and the other following two pairs of rollers 12, 11 are shifted from the uppermost position to the initial position on the left in Fig. 1 for receiving fresh hanks of yarn. The two alkali tanks 84, 84 are raised and the squeezing rollers 88, 88 and 91, 91 are returned to their normal position. The squeezing rollers 91, 91 squeeze the alkali out of the hanks of yarn 37 on the two first pairs of rollers 12, 11, which with the hanks 37 continue to move, so that the yarn is given the required gloss. Thereupon the two alkali tanks 84, 84 are lowered, the squeezing rollers 88, 88 are raised off the yarn and the squeezing rollers 91, 91 are moved off from the yarn, also the two pairs of splash plates 97, 97 are turned outward for allowing the pairs of rollers 12, 11 to move under them, and next the revolver is turned through a third angle of 90°, so that the first pairs of rollers 12, 11 come into the uppermost position, whereupon the splash plates 97, 97 are returned to their normal position shown. At the same time the valves proper in the two valve boxes 103, 103 are in the described manner opened for permitting the rinsing water or other liquid to fall on the hanks of yarn 37. Any splashing liquid will be caught by the splash plates 97, 97 and conducted to the two troughs 93, 93. After the two hanks of yarn 37 have been sufficiently rinsed, the valves in the valve boxes 103, 103 are closed, the splash plates 97, 97 are turned outward and the revolver is turned through a fourth angle of 90°, so that the two first pairs of rollers 12, 11 will cease moving while returning to their initial position, in which the movable rollers 11, 11 are raised by the bent arm 51, 49 engaging their shaft 9, whereupon the two treated hanks of yarn 37 are replaced by fresh ones.

The yarn mercerizing machine described may be varied without departing from the spirit of my invention.

I claim:

1. In a yarn mercerizing machine, the combination with a frame, of a revolver turnable in said frame, a plurality of pairs of roller shafts disposed in the periphery of said revolver, one roller shaft of each pair being stationary and the other roller shaft tangentially movable, rollers fastened at the ends of said roller shafts and each pair adapted to receive a hank of yarn, two parallel races surrounding said revolver and each forming the greater part of a concentric circle with tangents and consisting of

sections, of which the two outer ones are at the ends mounted to rock on pins at said frame, while all of them are pivotally connected with one another by radial links, means for constantly pressing the sections of said two races toward the axis of said revolver while preventing a distortion of the circular form of the races, and means for transmitting the pressure of said races to the movable roller shafts in said revolver, whereby the hanks of yarn on all pairs of rollers except in the initial position are tightened.

2. In a yarn mercerizing machine, the combination with a frame, of a revolver turnable in said frame and having in its periphery a plurality of pairs of bearings, one bearing of each pair being stationary and the other tangentially movable, roller shafts turnable in the bearings of said revolver and carrying at the ends rollers, the rollers of each pair being adapted to receive a hank of yarn, means for alternately turning said revolver through an angle and stopping it so as to bring each pair of rollers into the position of the preceding pair, bell-crank levers in two parallel planes on said revolver and having each one arm pivotally connected with one movable bearing, while the other arm carries a pressing roller, two races for said pressing rollers surrounding said revolver, each race forming the greater part of a circle with adjoining tangents and consisting of sections, of which the outer ones are at the ends mounted to rock on pins at said frame, while all of them are pivotally connected with one another by radial links, levers and links on said frame connected with the sections of said two races near their radial links, means for constantly pressing by said levers and links the sections of said two races toward the axis of said revolver, whereby all the hanks of yarn except in an initial position are tightened, and means for constantly driving the stationary roller shafts of all pairs except one occupying the initial position.

3. In a yarn mercerizing machine, the combination with a frame, of a revolver turnable in said frame, a plurality of pairs of roller shafts disposed in the periphery of said revolver, one roller shaft of each pair being stationary and the other roller shaft tangentially movable, rollers fastened at the ends of said roller shafts and each pair adapted to receive a hank of yarn, pressing rollers guided in said revolver in two parallel planes at right angles to its axis, means for transmitting the motion of said pressing rollers to the movable roller shafts in said revolver, two races for said pressing rollers surrounding said revolver, each race forming the greater part of a circle with adjoining tangents and consisting of

sections, of which the outer ones are at the
ends mounted to rock on pins at said frame,
while all of them are pivotally connected
with one another by radial links, levers and
5 links on said frame connected with the sec-
tions of said two races near their radial
links, means for constantly pressing by said
levers and links the sections of said two
races toward the axis of said revolver,
10 whereby all the hanks of yarn except in an
initial position are tightened, and means for

constantly driving the stationary roller
shafts of all pairs except one occupying the
initial position.

In testimony whereof I have signed my 15
name to this specification in the presence of
two subscribing witnesses.

PAUL HAHN.

Witnesses:

JUST BROSE,
LOUIS VANDORN.

Copies of this patent may be obtained for five cents each, by addressing the "Commissioner of Patents,
Washington, D. C."
