

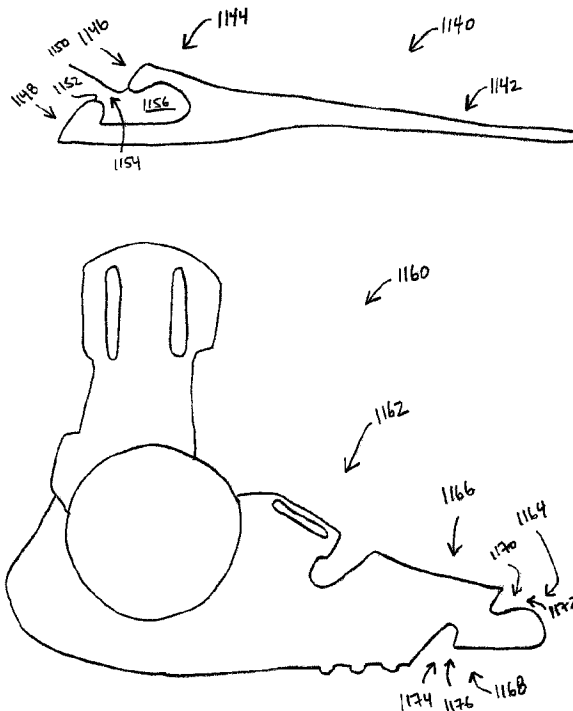

(22) Date de dépôt/Filing Date: 2011/04/07
(41) Mise à la disp. pub./Open to Public Insp.: 2011/10/13
(45) Date de délivrance/Issue Date: 2021/04/06
(62) Demande originale/Original Application: 2 796 127
(30) Priorité/Priority: 2010/04/08 (US61/322104)

(51) Cl.Int./Int.Cl. *A63B 31/11* (2006.01),
A43B 5/00 (2006.01), *B63H 1/36* (2006.01)
(72) Inventeur/Inventor:
ORTWIG, JAN PETER, CA
(73) Propriétaire/Owner:
HIEBLER SPORTS GMBH, AT
(74) Agent: SMART & BIGGAR LLP

(54) Titre : PALMES, BOTTES, SYSTEMES COMPRENANT CES DERNIERES, ET LEURS PROCEDES D'UTILISATION
(54) Title: FLIPPERS, BOOTS, SYSTEMS INCLUDING SAME, AND METHODS OF USING SAME



(57) Abrégé/Abstract:

A first flipper has a base, a deformable fin connected to the base, and a first spreader that imposes a first force on the fin that causes the fin to spread in response to relative movement between the first spreader and the fin caused by a first longitudinal deflection of the fin relative to the base. A second flipper has a fin and a foot coupling portion connectable to a foot holding portion of a boot to couple a foot in the foot holding portion to the flipper. A first system includes the flipper and the boot. Methods of using the flippers, the boot, and the system are also disclosed.

ABSTRACT

5 A first flipper has a base, a deformable fin connected to the base, and a first spreader that imposes a first force on the fin that causes the fin to spread in response to relative movement between the first spreader and the fin caused by a first longitudinal deflection of the fin relative to the base. A second flipper has a fin and a foot coupling portion connectable to a foot holding portion of a boot to couple a foot in the foot holding portion to the flipper. A first system includes the flipper and the boot. Methods of using the flippers, the boot, and the system are also disclosed.

**FLIPPERS, BOOTS, SYSTEMS INCLUDING SAME,
AND METHODS OF USING SAME**

This application claims the benefit of United States provisional patent application no. 61/322,104 filed April 8, 2010.

5 FIELD

This invention relates generally to flippers and boots, and more particularly to flippers, boots, systems including the flippers and boots, and methods of using the flippers, boots, and systems.

DESCRIPTION OF RELATED ART

10 A user can couple a known flipper to each foot of the user. These known flippers have fins, and when the user kicks in water, for example, the fins can facilitate generating propulsion in the water.

Many known flippers react passively to kicks in water. For example, in many known flippers, the fins maintain generally constant shapes in response to a kick in water.

15 These fins can disadvantageously generate inefficient water flow around the fins. For example, water in the kick path of the fin may be displaced towards lateral sides or a front side of the fin, and such water generally does not contribute to propulsion, disadvantageously reducing efficiency of the flipper.

Other known fins change shape in response to a kick in water, but water in the kick path
20 of these fins generally causes longitudinal center portions of these fins to be displaced away from longitudinal lateral portions of these fins opposite a direction of the kick, causing these fins to curve and become narrower in response to a kick. These fins therefore have reduced widths and thus reduced effective areas during a kick and greater widths when the user is not kicking. Thus, during a kick, effective areas of these
25 fins are disadvantageously reduced. When the user is not kicking, the fin is wider, disadvantageously causing greater drag in the water.

Also, many known flippers have foot pockets for receiving a foot of a user, but these foot pockets are generally integral to the fin and available only in a small number of standard sizes. Therefore, when a user selects a flipper, a user must also select a single foot pocket size of the flipper, often from among a small number of available sizes. Therefore, these foot pockets often do not comfortably fit a foot of a user, and space between the foot and an inside wall of the foot pocket can receive water, disadvantageously adding to drag of the flipper in water and limiting the control of the user over the flipper.

SUMMARY OF THE INVENTION

10 In accordance with one aspect of the invention, there is provided a method of changing a lateral shape of a deformable fin having first and second laterally opposite side elements connected to a base by respective first and second hinges. The method involves causing a first distal end of a first spreader having a first proximal end coupled to the base to impose a first force on the fin in response to relative movement between the first spreader and the fin caused by a first longitudinal deflection of the fin relative to the base in a first deflection direction. The method also involves using the first force from the first spreader to spread the first and second laterally opposite side elements apart.

15 In accordance with another aspect of the invention, there is provided a method of coupling a foot to a flipper having a fin coupled to a foot coupling portion. The method involves: connecting a first connector on a first end of the foot coupling portion to a first complementary connector in a first region of a foot holding portion of a boot; and connecting a second connector on a second end of the foot coupling portion opposite the first end of the foot coupling portion to a second complementary connector in a second region of the foot holding portion of the boot spaced apart from the first region of the foot holding portion of the boot.

20 In accordance with another aspect of the invention, there is provided a flipper apparatus including: a base; a deformable fin having first and second laterally opposite side elements; first and second hinges connecting the first and second laterally opposite side elements respectively to the base; first means for imposing a first force on the fin in

response to relative movement between the first means for imposing and the fin caused by a first longitudinal deflection of the fin relative to the base in a first deflection direction; and means for using the first force from the first means for imposing to spread the first and second laterally opposite side elements apart.

5 In accordance with another aspect of the invention, there is provided a flipper apparatus coupleable to a boot having a foot holding portion having first and second spaced-apart regions. The apparatus includes a fin and a foot coupling portion coupled to the fin. The foot coupling portion has: first and second opposite ends; a first connecting means on
10 the first end of the foot coupling portion for connecting with a first complementary connecting means in the first region of the foot holding portion of the boot; and a second connecting means on the second end of the foot coupling portion for connecting with a second complementary connecting means in the second region of the foot holding portion of the boot.

15 In accordance with another aspect of the invention, there is provided a boot coupleable to a flipper having a foot coupling portion having first and second opposite ends. The boot includes: a foot holding portion having first and second spaced-apart regions; a first connecting means of the first region of the foot holding portion for connecting with a first complementary connecting means on the first end of the foot coupling portion of the flipper; and a second connecting means of the second region of the foot holding portion
20 for connecting with a second complementary connecting means on the second end of the foot coupling portion of the flipper.

In accordance with another aspect of the invention, there is provided a flipper system including the flipper and the boot.

25 In accordance with another aspect of the invention, there is provided a flipper apparatus including: a base; a deformable fin having first and second laterally opposite side elements; first and second hinges connecting the first and second laterally opposite side elements respectively to the base; and a first spreader having a first proximal end coupled to the base and a first distal end operably configured to impose a first force on

the fin and to spread the first and second laterally opposite side elements to spread apart in response to relative movement between the first spreader and the fin caused by a first longitudinal deflection of the fin relative to the base in a first deflection direction.

5 In accordance with another aspect of the invention, there is provided a flipper apparatus coupleable to a boot having a foot holding portion having first and second spaced-apart regions. The apparatus includes a fin and a foot coupling portion coupled to the fin. The foot coupling portion has: first and second opposite ends; a first connector on the first end of the foot coupling portion configured to connect with a first complementary connector in the first region of the foot holding portion of the boot; and a second
10 connector on the second end of the foot coupling portion configured to connect with a second complementary connector in the second region of the foot holding portion of the boot.

15 In accordance with another aspect of the invention, there is provided a boot coupleable to a flipper having a foot coupling portion having first and second opposite ends. The boot includes: a foot holding portion having first and second spaced-apart regions; a first connector of the first region of the foot holding portion configured to connect with a first complementary connector on the first end of the foot coupling portion of the flipper; and a second connector of the second region of the foot holding portion configured to connect with a second complementary connector on the second end of
20 the foot coupling portion of the flipper.

In accordance with another aspect of the invention, there is provided a flipper system including the flipper and the boot.

25 In accordance with another aspect of the invention, there is provided a method of coupling a boot body to a fin apparatus comprising a fin body coupled to a foot coupling portion, the method comprising: connecting a first boot connector on the foot coupling portion to a first complementary boot connector on a top side of the boot body; and connecting a second boot connector on the foot coupling portion to a second complementary boot connector on a bottom side of the boot body; wherein

connecting the second boot connector to the second complementary boot connector comprises positioning a holding surface of the second boot connector against a retaining surface on the bottom side of the boot body; and wherein the retaining surface on the bottom side of the boot body is positioned to retain the second boot connector against movement in a direction towards the fin body when the holding surface of the second boot connector is positioned against the retaining surface on the bottom side of the boot body.

In accordance with another aspect of the invention, there is provided a fin apparatus coupleable to a boot body, the fin apparatus comprising a fin body. The apparatus further comprises a foot coupling portion coupled to the fin body and comprising: a first boot connector connectable with a first complementary boot connector on a top side of the boot body; and a second boot connector connectable with a second complementary boot connector on a bottom side of the boot body. The second boot connector comprises a holding surface positionable against a retaining surface on the bottom side of the boot body. The second boot connector is configured to be retained against movement in a direction towards the fin body when the holding surface of the second boot connector is positioned against the retaining surface on the bottom side of the boot body.

In accordance with another aspect of the invention, there is provided a system comprising: the apparatus; and the boot body. The boot body comprises: the first complementary boot connector on the top side of the boot body; and the second complementary boot connector on the bottom side of the boot body. The second complementary boot connector comprises the retaining surface on the bottom side of the boot body. The retaining surface on the bottom side of the boot body is positioned to retain the second boot connector against movement in the direction towards the fin body when the holding surface of the second boot connector is positioned against the retaining surface on the bottom side of the boot body.

In accordance with another aspect of the invention, there is provided a boot body coupleable to a fin apparatus comprising a fin body and a foot coupling portion, the boot body comprising: a first boot connector on a top side of the boot body connectable with a first complementary boot connector on the foot coupling portion; and a second boot connector on a bottom side of the boot body connectable with a second complementary boot connector on the foot coupling portion. The second boot connector comprises a retaining surface on the bottom side of the boot body for contacting a holding surface on the second complementary boot connector. The retaining surface on the bottom side of the boot body is positioned to retain the second complementary boot connector against movement in a direction towards the fin body when the holding surface of the second complementary boot connector is positioned against the retaining surface on the bottom side of the boot body.

Other aspects and features of the present invention will become apparent to those ordinarily skilled in the art upon review of the following description of specific embodiments of the invention in conjunction with the accompanying figures.

BRIEF DESCRIPTION OF THE DRAWINGS

In drawings that illustrate embodiments of the invention:

- Figure 1 is an exploded bottom view of a flipper in accordance with an embodiment of the invention;
- Figure 2 is a bottom oblique view of the flipper of Figure 1, showing an undeflected fin of the flipper of Figure 1;
- 5 Figure 3 is a bottom oblique view of the flipper of Figure 1, showing the fin of the flipper of Figure 1 deflected in a downward direction in response to an upward kick;
- Figure 4 is a cross-sectional view of the flipper of Figure 1, taken along the line IV-IV in Figure 3;
- 10 Figure 5 is a bottom oblique view of the flipper of Figure 1, showing the fin of the flipper of Figure 1 deflected upward in response to a downward kick;
- Figure 6 is a cross-sectional view of the flipper of Figure 1, taken along the line VI-VI in Figure 5;
- Figure 7 is an exploded bottom view of a flipper in accordance with another embodiment of the invention;
- 15 Figure 8 is an exploded bottom view of a flipper in accordance with another embodiment of the invention;
- Figure 9 is an exploded bottom view of a flipper in accordance with another embodiment of the invention;
- 20 Figure 10 is a bottom oblique view of the flipper of Figure 9, showing an undeflected fin of the flipper of Figure 9;
- Figure 11 is a bottom oblique view of the flipper of Figure 9, showing the fin of the flipper of Figure 9 deflected upward in response to a downward kick;
- Figure 12 is an exploded bottom oblique view of a flipper in accordance with another embodiment of the invention, showing an undeflected fin of the flipper of
- 25 Figure 12;
- Figure 13 is a bottom oblique view of the flipper of Figure 12, showing the fin of the flipper of Figure 12 deflected downward in response to an upward kick;
- Figure 14 is a top oblique view of the flipper of Figure 12, showing the fin of the
- 30 flipper of Figure 12 deflected upward in response to a downward kick;

- Figure 15 is an exploded bottom view of a flipper in accordance with another embodiment of the invention;
- Figure 16 is a bottom view of the flipper of Figure 15, showing an undeflected fin of the flipper of Figure 15;
- 5 Figure 17 is a cross-sectional view of the flipper of Figure 15, taken along the line XVII - XVII in Figure 16;
- Figure 18 is a cross-sectional view of the flipper of Figure 15, taken along the line XVIII – XVIII in Figure 16;
- Figure 19 is a bottom oblique view of the flipper of Figure 15, showing the fin of the flipper of Figure 15 deflected upward in response to a downward kick;
- 10 Figure 20 is a cross-sectional view of the flipper of Figure 15, taken along the line XX – XX in Figure 19;
- Figure 21 is an exploded bottom view of a flipper in accordance with another embodiment of the invention;
- 15 Figure 22 is a bottom view of the flipper of Figure 21, showing an undeflected fin of the flipper of Figure 21;
- Figure 23 is a cross-sectional view of the flipper of Figure 21, taken along the line XXIII – XXIII in Figure 22;
- Figure 24 is a bottom oblique view of the flipper of Figure 21, showing the fin of the flipper of Figure 21 deflected upward in response to a downward kick;
- 20 Figure 25 is a cross-sectional view of the flipper of Figure 21, taken along the line XXV – XXV in Figure 24;
- Figure 26 is an exploded bottom view of a flipper in accordance with another embodiment of the invention;
- 25 Figure 27 is an exploded bottom view of a flipper in accordance with another embodiment of the invention;
- Figure 28 is a bottom view of the flipper of Figure 27, showing an undeflected fin of the flipper of Figure 27;
- Figure 29 is a cross-sectional view of the flipper of Figure 27, taken along the line XXVIII – XXVIII in Figure 28;
- 30

- Figure **30** is a bottom oblique view of the flipper of Figure **27**, showing the fin of the flipper of Figure **27** deflected downward in response to an upward kick;
- Figure **31** is a bottom view of a flipper in accordance with another embodiment of the invention;
- 5 Figure **32** is a bottom view of a flipper in accordance with another embodiment of the invention, showing an undeflected fin of the flipper of Figure **32**;
- Figure **33** is a cross-sectional view of the flipper of Figure **32**, taken along the line XXXIII – XXXIII in Figure **32**;
- Figure **34** is a bottom oblique view of the flipper of Figure **32**, showing the fin of the flipper of Figure **32** deflected upward in response to a downward kick;
- 10 Figure **35** is a cross-sectional view of the flipper of Figure **32**, taken along the line XXXV – XXXV in Figure **34**;
- Figure **36** is an oblique top view of a flipper in accordance with another embodiment of the invention;
- 15 Figure **37** is a side view of a boot shell in accordance with another embodiment of the invention;
- Figure **38** is a side view of a boot in accordance with another embodiment of the invention;
- Figure **39** is a side view of a boot-flipper system in accordance with another embodiment of the invention;
- 20 Figure **40** is a bottom view of a flipper in accordance with another embodiment of the invention;
- Figure **41** is a cross-sectional view of the flipper of Figure **40**, taken along the line XLI-XLI in Figure **40**;
- 25 Figure **42** is a cross-sectional view of the flipper of Figure **40**, taken along the line XLII-XLII in Figure **40**;
- Figure **43** is a side view of a flipper in accordance with another embodiment of the invention; and
- Figure **44** is a side view of a boot shell in accordance with another embodiment of the invention.
- 30

DETAILED DESCRIPTION

Referring to Figure 1, a flipper in accordance with an embodiment of the invention is shown generally at **100**. The flipper **100** includes a base shown generally at **102**, a deformable fin shown generally at **104**, and a spreader **106**.

5 In the embodiment shown, the base **102** is made from a moderately flexible thermoplastic material. The thermoplastic materials in the various embodiments disclosed herein may include various known thermoplastic materials, such as thermoplastic polyurethane, polypropylene, polyamides, thermoplastic elastomers, styrene-butadiene-styrene, styrene-ethylene-butadiene-styrene, ethylene, polyolefine,
10 acetal resin, polyoxymethylene plastic such as Delrin™ or Delrin 107™, and/or combinations of two or more thereof, for example. These thermoplastic materials may also be fiber-infused, and/or include composite matrix materials including glass and/or carbon fibers, for example.

The base **102** defines a foot pocket **108** for receiving a foot of a user (not shown), and
15 a heel-retaining strap **110** extending from laterally opposite sides of the base **102** and across an opening of the foot pocket **108** for contacting a heel of the foot to hold the foot in the foot pocket **108**. The base **102** also has a bottom wall **112** defining through-holes **114**, **116**, and **118** for receiving fasteners **120**, **122**, and **124** respectively. The fasteners **120**, **122**, and **124** in the embodiment shown are metallic rivets, although it
20 will be appreciated that these fasteners may alternatively be threaded fasteners or other fasteners, for example.

When a user wearing the flipper **100** walks on a surface, the bottom wall **112** generally faces downward and therefore generally contacts the surface. In general, the “bottom” side of a flipper herein refers to a side of the flipper that faces downward and generally contacts a surface when a user of the flipper walks on the surface. However,
25 when using a flipper in water, a user generally faces downward, and therefore a “bottom” of a flipper herein refers to a surface that generally faces upward when the flipper is in use. A drawing of a “bottom view” herein generally refers to a view of such

a “bottom” side of a flipper, and in the case of a flipper in use, a “bottom view” herein therefore generally refers to a view from above.

5 The fin **104** has first and second laterally opposite side elements **126** and **128**, which in the embodiment shown are made from a relatively rigid thermoplastic material. Herein, a “relatively rigid thermoplastic material” may refer to a thermoplastic material having a modulus of elasticity of about **100** megapascals (MPa) to about **500** MPa, for example.

10 The fin **104** also has and an elastically deformable web **130** coupled to and extending between the first and second laterally opposite side elements **126** and **128**. In the embodiment shown, the web **130** is made from a relatively flexible thermoplastic material. Herein, a “relatively flexible thermoplastic material” may refer to a thermoplastic material having a modulus of elasticity of about **30** MPa to about **200** MPa, for example.

15 The first and second laterally opposite side elements **126** and **128** are connected to the base **102** by first and second hinges **132** and **134** respectively. The first and second hinges **132** and **134** respectively define first and second recesses shown generally at **136** and **138**. The first and second recesses **136** and **138** give the first and second hinges **132** and **134** respective minimum widths **140** and **142** that are less than respective widths **144** and **146** of the first and second laterally opposite side elements **126** and **128** respectively. In the embodiment shown, the first and second hinges **132** and **134** are made from a relatively flexible and resilient thermoplastic material, although the first and second hinges **132** and **134** also include first and second arcuate resilient restoring members **137** and **139** respectively surrounding the first and second recesses **136** and **138** respectively and made from a relatively rigid and resilient thermoplastic material.

In the embodiment shown, the base **102**, the first and second laterally opposite side elements **126** and **128**, the web **130**, and the first and second hinges **132** and **134** are

unitarily formed in a multi-stage injection moulding process, although alternatively these elements may be formed by other processes.

5 Because the first and second hinges **132** and **134** have respective minimum widths **140** and **142** that are less than the respective widths **144** and **146** of the first and second laterally opposite side elements **126** and **128** respectively, and because the first and second hinges are made from a more flexible material than the base **102** and the first and second laterally opposite side elements **126** and **128**, the flipper **100** is generally most flexible at the first and second hinges **132** and **134**. Therefore, the first and second laterally opposite side elements **126** and **128** have a tendency to rotate about first and second hinge axes **133** and **135** respectively of the first and second hinges **132** and **134** respectively in response to a kicking force applied by a foot coupled to the base **102** in a fluid such as water (not shown), for example. This rotation of the first and second laterally opposite side elements **126** and **128** about the first and second hinge axes **133** and **135** respectively facilitates longitudinal deflection of the fin **104** relative to the base **102**.

10 The first and second hinge axes **133** and **135** extend generally between the first and second recesses **136** and **138** respectively and an intersection region shown generally at **148** between the first and second laterally opposite side elements **126** and **128** and the base **102**. The first and second recesses **136** and **138** are disposed forwardly of (that is, in a direction toward the fin **104** and away from the base **102** from) the intersection region **148**. The first and second hinge axes **133** and **135** therefore extend away from a central longitudinal axis **149** of the fin **104** and away from the base **102** at respective acute angles **150** and **152** from the central longitudinal axis **149** of the fin **104**.

20 The first and second laterally opposite side elements **126** and **128** define first and second v-shaped guides shown generally at **160** and **162** respectively, which in the embodiment shown are channels extending through the first and second laterally opposite side elements **126** and **128** respectively.

The spreader **106** in the embodiment shown is made from a relatively rigid thermoplastic material, and has a proximal end shown generally at **164** and a distal end shown generally at **166**. At the proximal end **164**, the spreader **106** defines through-holes **168**, **170**, and **172** that are aligned with the through-holes **114**, **116**, and **118** in the bottom wall **112** of the base **102**. The through-holes **114**, **116**, **118** and the through-holes **168**, **170**, and **172** receive the fasteners **120**, **122**, and **124** respectively to couple the proximal end **164** of the spreader **106** to the base **102** and hold the proximal end **164** of the spreader **106** in a substantially fixed position relative to the base **102**.

At the distal end **166**, the spreader **106** defines through-holes **174** and **176**. The through-holes **174** and **176** and the first and second guides **160** and **162** respectively receive fasteners (which may also be referred to as “pins”) **178** and **180**. The fasteners **178** and **180** in the embodiment shown are metallic rivets, although it will be appreciated that these fasteners may alternatively be threaded fasteners or other fasteners, for example.

When the flipper **100** is not subjected to any deflecting forces, the flipper **100** may be referred to as being undeflected, such that the bottom wall **112** of the base **102** is generally coplanar with the fin **104**, and the spreader **106** is generally planar, and parallel to and spaced apart from, the bottom wall **112** and the fin **104**. When the flipper **100** is undeflected, the fasteners **178** and **180** are disposed at respective undeflected positions shown generally at **182** and **184** at respective apexes of the first and second guides **160** and **162**.

However, the fasteners **178** and **180** can slide away from the respective undeflected positions **182** and **184** towards respective inner proximal ends shown generally at **186** and **188** of the first and second guides **160** and **162**, or towards respective inner distal ends shown generally at **190** and **192** of the first and second guides **160** and **162** respectively. Therefore, while the proximal end **164** of the spreader **106** is held in a substantially fixed position relative to the base **102**, the distal end **166** of the spreader

106 is coupled to the first and second laterally opposite side elements **126** and **128** and held longitudinally slidably to the fin **104**.

Referring to Figure **2**, the flipper **100** is shown with the spreader **106** thus held on the base **102** and fin **104** while the flipper **100** is undeflected.

5 Referring to Figure **3**, the flipper **100** is shown deflected in response to an upward kick in the direction of the arrow **194** of the user in a fluid such as water (not shown), for example. In response to the upward kick, the fin **104** deflects in a downward deflection direction longitudinally relative to the base **102** at the first and second hinges **132** and **134** in the direction of the arrow **196**.

10 Because the spreader **106** is on a same side of the base **102** and the fin **104**, the proximal end **164** of the spreader **106** is held in a substantially fixed position relative to the base **102** by the fasteners **120**, **122**, and **124**, and the distal end **166** of the spreader **106** is held longitudinally slidably to the fin **104**, the spreader **106** flexes longitudinally in response to the longitudinal deflection of the fin **104** relative to the base **102**, and remains generally parallel to and spaced apart from the fin **104**. Thus,
15 in response to longitudinal deflection of the fin **104** relative to the base **102** in the direction of the arrow **196**, the distal end **166** of the spreader **106** moves longitudinally relative to the fin **104** in the direction of the arrow **198**, thus urging the fasteners **178** and **180** towards the respective inner proximal ends **186** and **188** (shown in Figure **1**)
20 of the first and second guides **160** and **162** respectively.

As indicated above, the spreader **106** in the embodiment shown is made from a relatively rigid thermoplastic material, and therefore maintains a generally constant separation distance **199** between the fasteners **178** and **180**. Thus, as the fasteners **178** and **180** move relative to the fin **104** towards the respective inner proximal ends
25 (**186** and **188**) of the first and second guides **160** and **162** respectively in response to the longitudinal deflection of the fin **104**, the fasteners **178** and **180** slide along respective walls **200** and **202** of the first and second guides **160** and **162**, and impose respective thrust forces in the direction of the arrow **198** on the respective walls **200**

and **202**. These respective thrust forces may collectively be referred to as “a first force” and the spreader **106** thus imposes the first force on the fin **104** in response to relative movement between the distal end **166** of the spreader **106** and the fin **104** caused by longitudinal deflection of the fin **104** relative to the base **102**.

5 The walls **200** and **202** are disposed at respective acute angles **204** and **206** to the central longitudinal axis **149** (shown in Figure 1) of the fin **104**. Because the respective walls **200** and **202** of the first and second guides **160** and **162** are disposed at the respective acute angles (**204** and **206**) to the central longitudinal axis (**149**) of the fin **104**, and because the spreader **106** maintains the generally constant separation distance (**199**) between the fasteners **178** and **180**, the respective walls **200** and **202** receive and use the respective thrust forces caused by the longitudinal deflection of the fin **104** relative to the base **102** to cause the walls **200** and **202** to be pushed apart and thereby to cause the first and second laterally opposite side elements **126** and **128** to spread apart by moving or rotating laterally about the first and second hinges **132** and **134** respectively in the directions of the arrows **207** and **209** respectively. This spreading elastically deforms the elastically deformable web **130** by stretching the elastically deformable web **130** to accommodate the separation of the first and second laterally opposite side elements **126** and **128**, and changes a lateral shape of the fin **104**.

20 When the first and second laterally opposite side elements **126** and **128** move laterally about the first and second hinges **132** and **134**, respective regions shown generally at **208** and **210** of the first and second laterally opposite side elements **126** and **128** move into the first and second recesses **136** and **138** respectively. The first and second recesses **136** and **138** thus accommodate lateral movement of the first and second laterally opposite side elements **126** and **128** respectively about the first and second hinges **132** and **134** respectively.

25 As the respective regions **208** and **210** of the first and second laterally opposite side elements **126** and **128** move into the first and second recesses **136** and **138** respectively, the first and second arcuate resilient restoring members **137** and **139** are

resiliently deformed, storing therein elastic potential energy. This elastic potential energy is usable to facilitate moving the first and second laterally opposite side elements **126** and **128** in respective directions opposite the directions of the arrows **207** and **209** respectively as the fin is restored to the undeflected position shown in Figure 2.

As shown in Figure 1 and discussed above, the first and second hinge axes **133** and **135** are disposed at respective acute angles **150** and **152** to the central longitudinal axis **149** of the fin **104**. Referring to Figures 1, 3, and 4, due to the acute angles **150** and **152** of the first and second hinge axes **133** and **135**, when the first and second laterally opposite side elements **126** and **128** rotate about the first and second hinge axes **133** and **135** respectively, respective inner sides **214** and **216** of the first and second laterally opposite side elements **126** and **128** move in the downward deflection direction of the arrow **196** by a greater distance than respective outer sides **218** and **220** of the first and second laterally opposite side elements **126** and **128**. The first and second hinges **132** and **134** thus impart a concave shape to the fin **104**, opposite the downward deflection direction of the arrow **196**, when the first and second laterally opposite side elements **126** and **128** are rotated about the first and second hinge axes **133** and **135** respectively in response to longitudinal deflection of the fin **104** relative to the base **102**.

In different embodiments, the acute angles **150** and **152** may be varied to vary the degree of concavity that results from longitudinal deflection of the fin **104** relative to the base **102**. For example, the angles **150** and **152** may be reduced generally to increase concavity that results from longitudinal deflection of the fin **104** relative to the base **102**. Alternatively, the acute angles **150** and **152** may be increased generally to decrease concavity that results from longitudinal deflection of the fin **104** relative to the base **102**.

Referring to Figure 5, the flipper **100** is shown deflected in response to a downward kick in the direction of the arrow **222** of the user in a fluid such as water (not shown), for example. In response to the downward kick, the fin **104** deflects in an upward

deflection direction longitudinally relative to the base **102** at the first and second hinges **132** and **134** in the direction of the arrow **224**.

5 As with the upward kick shown in Figure **3**, the spreader **106** flexes longitudinally in response to the longitudinal deflection of the fin **104** relative to the base **102**, and remains generally parallel to and spaced apart from the fin **104**. Thus, in response to the longitudinal deflection of the fin **104** relative to the base **102** in the direction of the arrow **224**, the distal end **166** of the spreader **106** moves longitudinally relative to the fin **104** in the direction of the arrow **226**, thus urging the fasteners **178** and **180** towards the respective inner distal ends **190** and **192** of the first and second guides **160** and **162** respectively (shown in Figure **1**).

10 Again, the spreader **106** maintains the generally constant separation distance **199** between the fasteners **178** and **180**, such that as the fasteners **178** and **180** move towards the respective inner distal ends (**190** and **192**) of the first and second guides (**160** and **162**), the fasteners **178** and **180** slide along respective walls **228** and **230** of the first and second guides **160** and **162** (shown in Figure **1**), and impose respective thrust forces (which again may be collectively referred to as "a first force") in the direction of the arrow **226** on the respective walls (**228** and **230**).

15 The walls **228** and **230** are also disposed at respective acute angles **232** and **234** to the central longitudinal axis **149** (shown in Figure **1**) of the fin **104**. As with the upward kick shown in Figure **3**, the downward kick shown in Figure **5** causes the respective walls (**228** and **230**) of the first and second guides **160** and **162** to receive and use the respective thrust forces by causing the walls (**228** and **230**) to separate, and thereby causing the first and second laterally opposite side elements **126** and **128** to spread apart by moving or rotating laterally about the first and second hinges **132** and **134** respectively in the directions of the arrows **235** and **237** respectively, elastically deforming and stretching the web **130**, causing the respective regions **208** and **210** of the first and second laterally opposite side elements **126** and **128** to move into the first and second recesses **136** and **138** respectively, and thereby changing a lateral shape of the fin **104**.

Referring to Figures 1, 5, and 6, as with the upward kick shown in Figure 3, because the first and second hinge axes 133 and 135 extend away from the central longitudinal axis 149 of the fin 104 and away from the base 102 at respective acute angles 150 and 152 from the central longitudinal axis 149 of the fin 104, the downward kick shown in Figure 5 causes the respective inner sides 214 and 216 of the first and second laterally opposite side elements 126 and 128 to move in the upward deflection direction of the arrow 224 by a greater distance than the respective outer sides 218 and 220 of the first and second laterally opposite side elements 126 and 128, and the first and second hinges 132 and 134 thus impart a concave shape to the fin 104 opposite the upward deflection direction of the arrow 224.

Referring to Figure 7, a flipper in accordance with another embodiment of the invention is shown generally at 240. The flipper 240 includes a base shown generally and 242, a deformable fin shown generally at 244, and a spreader 246. The base 242 is substantially the same as the base 102 shown in Figures 1 to 6, and includes a bottom wall 248 defining through-holes 250, 252, and 254 for receiving fasteners 256, 258, and 260 respectively. The fasteners 256, 258, and 260 in the embodiment shown are metallic rivets, although it will be appreciated that these fasteners may alternatively be threaded fasteners or other fasteners, for example.

The fin 244 has first and second laterally opposite side elements 262 and 264, which in the embodiment shown are made from a relatively rigid thermoplastic material.

The first and second laterally opposite side elements 262 and 264 are connected to the base 242 by first and second hinges 266 and 268 respectively. The first and second hinges 266 and 268 are substantially the same as the first and second hinges 132 and 134 shown in Figures 1 to 6, and therefore function in substantially the same way. For example, the first and second laterally opposite side elements 262 and 264 have a tendency to rotate about first and second hinge axes 270 and 272 respectively of the first and second hinges 266 and 268 respectively in response to a kicking force applied by a foot coupled to the base 242 in a fluid such as water (not shown), for example, to facilitate longitudinal deflection of the fin 244 relative to the base 242. The

first and second hinges **266** and **268** also have respective recesses that accommodate lateral movement of the first and second laterally opposite side elements **262** and **264** respectively about the first and second hinges **266** and **268** respectively, and the first and second hinges **266** and **268** have respective arcuate resilient restoring members (not shown) to facilitate restoring the first and second laterally opposite side elements **262** and **264** to respective undeflected positions. The first and second hinge axes **270** and **272** are also disposed at respective acute angles **271** and **273** to a central longitudinal axis **275** of the fin **244**, such that the first and second hinges **266** and **268** also impart a concave shape to the fin **244** opposite a deflection direction of longitudinal deflection of the fin **244** relative to the base **242** when the first and second laterally opposite side elements **262** and **264** are rotated about the first and second hinge axes **270** and **272**, as discussed above and illustrated in Figures **3** to **6**.

As discussed above in relation to the acute angles **150** and **152**, the acute angles **271** and **273** may be varied in different embodiments to vary a degree of concavity that results from longitudinal deflection of the fin **244** relative to the base **242**. More generally, such acute angles in other embodiments, such as other embodiments described herein for example, may be varied to vary such degrees of concavity.

The first laterally opposite side element **262** defines a first plurality of v-shaped guides, which in the embodiment shown includes v-shaped guides shown generally at **274**, **276**, and **278**. The second laterally opposite side element **264** defines a second plurality of v-shaped guides, which in the embodiment shown includes v-shaped guides shown generally at **280**, **282**, and **284**.

In the embodiment shown, the base **242**, the first and second laterally opposite side elements **262** and **264**, and the first and second hinges **266** and **268** are unitarily formed in a multi-stage injection moulding process, although alternatively these elements may be formed by other processes.

The spreader **246** in the embodiment shown is made from a relatively rigid thermoplastic material, and has a proximal end shown generally at **286** and a distal end shown generally at **290**. At the proximal end **286**, the spreader **246** defines through-holes **292**, **294**, and **296** that are aligned with to the through-holes **250**, **252**, and **254** in the bottom wall **248** of the base **242**. The through-holes **250**, **252**, and **254** and the through-holes **292**, **294**, and **296** receive the fasteners **256**, **258**, and **260** respectively to couple the proximal end **286** of the spreader **246** to the base **242** and hold the proximal end **286** of the spreader **246** in a substantially fixed position relative to the base **242**.

At the distal end **290**, the spreader **246** defines through-holes **298**, **300**, **302**, **304**, **306**, and **308**. The through-holes **298**, **300**, **302**, **304**, **306**, and **308** and the v-shaped guides **274**, **276**, **278**, **280**, **282**, and **284** respectively receive fasteners (which may also be referred to as "pins") **310**, **312**, **314**, **316**, **318**, and **320**. The fasteners **310**, **312**, **314**, **316**, **318**, and **320** in the embodiment shown are metallic rivets, although it will be appreciated that these fasteners may alternatively be threaded fasteners or other fasteners, for example. The fasteners **310**, **312**, **314**, **316**, **318**, and **320** couple the distal end **290** of the spreader **246** to the first and second laterally opposite side elements **262** and **264**, hold the distal end **290** of the spreader **246** longitudinally slidably to the fin **244**.

As indicated above, the spreader **246** is made from a relatively rigid thermoplastic material, and therefore maintains a generally constant separation distance **322** between corresponding fasteners **310** and **316**, a generally constant separation distance **324** between corresponding fasteners **312** and **318**, and a generally constant separation distance **326** between corresponding fasteners **314** and **320**.

When the flipper **240** is not subjected to any deflecting forces, the flipper **240** may be referred to as being undeflected, such that the bottom wall **248** of the base **242** is generally coplanar with the fin **244**, and the spreader **246** is generally planar, and parallel to and spaced apart from, the bottom wall **248** and the fin **244**. When the flipper **240** is undeflected, the fasteners **310**, **312**, **314**, **316**, **318**, and **320** are

disposed at respective undeflected positions shown generally at **328, 330, 332, 334, 336, and 338** at respective apexes of the v-shaped guides **274, 276, 278, 280, 282, and 284** respectively. However, the fasteners **310, 312, 314, 316, 318, and 320** can slide away from the respective undeflected positions **328, 330, 332, 334, 336, and 338** towards respective proximal inner ends of the v-shaped guides **274, 276, 278, 280, 282, and 284**, or towards respective distal inner ends v-shaped guides **274, 276, 278, 280, 282, and 284**.

As with the flipper **100** shown in Figures **1 to 6**, the fin **244** deflects in a deflection direction longitudinally relative to the base **242** at the first and second hinges **266 and 268** in response to a kick of a user in a fluid such as water (not shown), for example. In response to the longitudinal deflection of the fin **244** relative to the base **242**, the spreader **246** flexes longitudinally and remains generally parallel to and spaced apart from the fin **244**, and the distal end **290** of the spreader **246** moves longitudinally relative to the fin **244**. The fasteners **310, 312, 314, 316, 318, and 320** slide along respective walls of the v-shaped guides **274, 276, 278, 280, 282, and 284**, the respective walls being disposed at respective acute angles to the central longitudinal axis **275** of the fin **244**. The fasteners **310, 312, 314, 316, 318, and 320** thus impose respective thrust forces (may be collectively referred to as “a first force”) in the direction of the longitudinal movement of the distal end **290** of the spreader **246** relative to the fin **244** on the respective walls of the v-shaped guides **274, 276, 278, 280, 282, and 284**, and the respective walls use the respective thrust forces to separate the first and second laterally opposite side elements **262 and 264** and change a lateral shape of the fin **244** in substantially the same way as discussed above and shown in Figures **1 to 6**.

Advantageously, the first and second pluralities of v-shaped guides shown in Figure **7** permit control over how the lateral shape of the fin **244** is changed at a plurality of points along the length of the fin **244** in response to longitudinal deflection of the fin **244** relative to the base **242**. For example, the respective angles to the central longitudinal axis **275** of the respective walls of the respective v-shaped guides may differ to permit differing spreading along the length of the fin **244**.

Referring to Figure 8, a flipper in accordance with another embodiment of the invention is shown generally at **350**. The flipper **350** includes a base shown generally at **352**, a deformable fin shown generally at **354**, and a spreader **356**. The base **352** is substantially the same as the base **102** shown in Figures 1 to 6.

5 The fin **354** has first and second laterally opposite side elements **358** and **360**, which in the embodiment shown are made from a relatively rigid thermoplastic material. The fin **354** also has an elastically deformable web **362** coupled to and extending between the first and second laterally opposite side elements **358** and **360**. In the embodiment shown, the web **362** is made from a relatively flexible thermoplastic material. The first
10 and second laterally opposite side elements **358** and **360** are connected to the base **352** by first and second hinges **364** and **366** respectively. The first and second hinges **364** and **366** are substantially the same as the first and second hinges **132** and **134** respectively shown in Figures 1 to 6, and therefore function in substantially the same way. The first and second laterally opposite side elements **358** and **360** define first
15 and second v-shaped guides shown generally at **368** and **370**.

In the embodiment shown, the base **352**, the first and second laterally opposite side elements **358** and **360**, and the first and second hinges **364** and **366** are unitarily formed in a multi-stage injection moulding process, although alternatively these elements may be formed by other processes.

20 The spreader **356** in the embodiment shown is made from a relatively rigid thermoplastic material, and has a proximal end shown generally at **372** and a distal end shown generally at **374**. The proximal end **372** of the spreader **356** is coupled to the base **352** and held in a substantially fixed position relative to the base **352** in substantially the same manner as discussed above and illustrated in Figures 1 and 7.

25 At the distal end **374**, the spreader **356** includes first and second elongate members **376** and **378** separated by an opening shown generally at **380**. The first and second elongate members **376** and **378** define respective through-openings **382** and **384** for receiving respective fasteners (which may also be referred to as "pins") **386** and **388**.

The fasteners **386** and **388** in the embodiment shown are metallic rivets, although it will be appreciated that these fasteners may alternatively be threaded fasteners or other fasteners, for example. The spreader **356** maintains a generally constant separation distance **390** between the fasteners **386** and **388**. The spreader **356** functions in substantially the same way as the spreader **106** discussed above and shown in Figures **1** to **6**, and the fasteners **386** and **388** cooperate with the first and second guides **368** and **370** in substantially the same manner as the fasteners **178** and **180** cooperate with the first and second guides **160** and **162** as discussed above and shown in Figures **1** to **6**.

The first and second laterally opposite side elements **358** and **360** are generally narrower than the first and second laterally opposite side elements **126** and **128** shown in Figures **1** to **6**, such that the web **362** is generally wider than the web **130** shown in Figures **1** to **6**. The opening **380** between the first and second elongate members **376** and **378** at the distal end **374** of the spreader **356** permits the web **362** to pass therethrough when the fin **354** is deflected longitudinally relative to the base **352** during operation of the flipper **350**. The relatively greater width of the web **362** permits a more continuously curved concavity of the fin **354**.

Referring to Figure **9**, a flipper in accordance with another embodiment of the invention is shown generally at **400**. The flipper **400** includes a base shown generally at **402**, a deformable fin shown generally at **404**, and a spreader **406**.

In the embodiment shown, the base **402** is made from a moderately flexible thermoplastic material. The base **402** defines a foot pocket **408** for receiving a foot of a user (not shown), and a heel-retaining strap **410** extending from laterally opposite sides of the base **402** and across an opening of the foot pocket **408** for contacting a heel of the foot to hold the foot in the foot pocket **408**. The base **402** also has a bottom wall **412** defining an opening **414** in communication with a threaded receptacle (not shown) in the base **402** for receiving a threaded fastener **416**. In the embodiment shown, the threaded fastener **416** and the threaded receptacle are metallic, although it will be appreciated that other fasteners and receptacles may alternatively be used.

The fin **404** has first and second laterally opposite side elements **418** and **420**, which in the embodiment shown are made from a relatively rigid thermoplastic material. The fin **404** also has an elastically deformable web **422** coupled to and extending between the first and second laterally opposite side elements **418** and **420**. In the embodiment shown, the web **422** is made from a relatively flexible thermoplastic material. The first and second laterally opposite side elements **418** and **420** are connected to the base **402** by first and second hinges **424** and **426** respectively. The first and second hinges **424** and **426** are substantially the same as the first and second hinges **132** and **134** respectively shown in Figures **1** to **6**, and therefore function in substantially the same way.

In the embodiment shown, the base **402**, the first and second laterally opposite side elements **418** and **420**, and the first and second hinges **424** and **426** are unitarily formed in a multi-stage injection moulding process, although alternatively these elements may be formed by other processes.

The spreader **406** in the embodiment shown is made from a relatively rigid thermoplastic material, and has a proximal end shown generally at **428** and a distal end shown generally at **430**. At the proximal end **428**, the spreader **406** defines a through-channel **432** for receiving the threaded fastener **416** at a selectable position along a length of the through-channel **432**. The threaded fastener **416** thus couples the proximal end **428** of the spreader **406** to the base **402**, and holds the proximal end **428** of the spreader **406** in a substantially fixed position relative to the base **402**. However, the threaded fastener **416** can hold the proximal end **428** of the spreader **406** at various selectable positions along the length of the through-channel **432**, and thus the substantially fixed position of the proximal end **428** of the spreader **406** relative to the base **402** is adjustable.

At the distal end **430**, the spreader **406** defines a through-hole **434** for receiving a fastener **436**. The fastener **436** in the embodiment shown is a metallic rivet, although it will be appreciated that this fastener may alternatively be a threaded fastener or another fastener, for example.

The fin **404** has first and second force transfer elements **438** and **440**, which in the embodiment shown are made from a relatively rigid thermoplastic material. The first and second force transfer elements **438** and **440** have respective distal ends **442** and **444** and respective proximal ends **446** and **448**. The respective distal ends **442** and **444** of the first and second force transfer elements **438** and **440** are pivotally connected to the first and second laterally opposite side elements **418** and **420** respectively at respective pivots **450** and **452**. The pivots **450** and **452** in the embodiment shown are metallic rivets, although it will be appreciated that these pivots may alternatively be other fasteners, for example. At the respective proximal ends **446** and **448**, the first and second force transfer elements **438** and **440** define respective through-holes for receiving the fastener **436**. The fastener **436** thus couples and pivotally connects the distal end **430** of the spreader **406** to the respective proximal ends **446** and **448** of the first and second force transfer elements **438** and **440**.

When the flipper **400** is not subjected to any deflecting forces, the flipper **400** may be referred to as being undeflected, such that the bottom wall **412** of the base **402** is generally coplanar with the fin **404**, and the spreader **406** is generally planar, and parallel to and spaced apart from, the bottom wall **412** and the fin **404**. Referring to Figure **10**, the flipper **400** is shown undeflected. When the flipper **400** is undeflected, the first force transfer element **438** is at a first undeflected angle **454** from the spreader **406**, and the second force transfer element **440** is at a second undeflected angle **456** from the spreader **406**.

Referring to Figure **11**, the flipper **400** is shown deflected in response to a downward kick in the direction of arrow **458** of the user in a fluid such as water (not shown), for example. In response to the downward kick, the fin **404** deflects in an upward deflection direction longitudinally relative to the base **402** at the first and second hinges **424** and **426** in the direction of the arrow **460**.

Because the spreader **406** is on a same side of the base **402** and the fin **404**, the proximal end **428** of the spreader **406** is held in a substantially fixed position relative to the base **402**, the distal end **430** of the spreader **406** is pivotally connected to the

respective proximal ends **446** and **448** of the first and second force transfer elements **438** and **440**, and the respective distal ends **442** and **444** of the first and second force transfer elements **438** and **440** are pivotally connected to the first and second laterally opposite side elements **418** and **420** respectively, the spreader **406** flexes
5 longitudinally in response to the longitudinal deflection of the fin **404** relative to the base **402**, and remains generally parallel to and spaced apart from the fin **404**. Thus, in response to longitudinal deflection of the fin **404** relative to the base **402** in the direction of the arrow **460**, the distal end **430** of the spreader **406** moves longitudinally relative to the fin **404** in the direction of the arrow **462** and imposes a force on the
10 fastener **436** in the direction of the arrow **462**.

The force on the fastener **436** in the direction of the arrow **462** rotates the first and second force transfer elements **438** and **440** about the pivots **450** and **452**, thereby changing respective angles between the first and second force transfer elements **438** and **440** and the spreader **406** from the respective undeflected angles **454** and **456**
15 shown in Figure **10** to respective deflected angles **464** and **466**, which in the embodiment shown are less than the respective undeflected angles **454** and **456** respectively shown in Figure **10**. The longitudinal movement of the distal end **430** of the spreader **406** in the direction of the arrow **462** thereby spreads the first and second laterally opposite side elements **418** and **420** apart in the respective directions
20 of the arrows **467** and **469** respectively. The first and second force transfer elements **438** and **440** thus receive and use a force from the distal end **430** of the spreader **406** in response to longitudinal movement of the distal end **430** of the spreader **406** relative to the fin **404** to spread the first and second laterally opposite side elements **418** and **420** apart, thereby elastically deforming the web **422** by stretching the web
25 **422** to accommodate the spreading of the first and second laterally opposite side elements **418** and **420** apart, and thereby changing a lateral shape of the fin **404**.

Further, it will be appreciated that when the substantially fixed position of the proximal end **428** of the spreader **406** relative to the base **402** is adjusted by moving the threaded fastener **416** along the length of the through-channel **432**, the respective
30 undeflected angles **454** and **456** (shown in Figure **10**) of the first and second force

transfer elements **438** and **440** can be adjusted, as can the respective deflected angles **464** and **466**, thereby adjusting an amount of spreading of the first and second laterally opposite elements **418** and **420**.

5 Referring to Figure **12**, a flipper in accordance with another embodiment of the invention is shown generally at **470**. The flipper **470** includes a base shown generally at **472**, a deformable fin shown generally at **474**, a first spreader **476**, and a second spreader **478**.

10 In the embodiment shown, the base **472** is made from a moderately flexible thermoplastic material. The base **472** defines a foot pocket **480** for receiving a foot of a user (not shown), and a heel-retaining strap **482** extending from laterally opposite sides of the base **472** and across an opening of the foot pocket **480** for contacting a heel of the foot to hold the foot in the foot pocket **480**. The base **472** also has a bottom wall **484** defining an opening **486** in communication with a threaded receptacle (not shown) in the base **472** for receiving a threaded fastener **488**. The base **472** also has
15 a top wall **490** (also shown in Figure **14**) defining an opening **492** in communication with a threaded receptacle (not shown) in the base **402** for receiving a threaded fastener **494**. In the embodiment shown, the threaded fasteners **488** and **494** and the threaded receptacles are metallic, although it will be appreciated that alternatively other fasteners and receptacles may be used, for example.

20 The fin **474** has first and second laterally opposite side elements **496** and **498**, which in the embodiments shown are made from a relatively rigid thermoplastic material. The fin **474** also has an elastically deformable web **500** coupled to and extending between the first and second laterally opposite side elements **496** and **498**. In the embodiment shown, the web **500** is made from a relatively flexible thermoplastic material. The first and second laterally opposite side elements **496** and **498** are
25 connected to the base **472** by first and second hinges **502** and **504** respectively. The first and second hinges **502** and **504** are substantially the same as the first and second hinges **132** and **134** respectively shown in Figures **1** to **6**, and therefore function in substantially the same way.

In the embodiment shown, the base **472**, the first and second laterally opposite side elements **496** and **498**, the web **500**, and the first and second hinges **502** and **504** are unitarily formed in a multi-stage injection moulding process, although alternatively these elements may be formed by other processes.

5 The first spreader **476** in the embodiment shown is made from a relatively rigid thermoplastic material, and has a first proximal end shown generally at **506** and a first distal end shown generally at **508**. At the first proximal end **506**, the first spreader **476** defines a through-channel **510** for receiving the threaded fastener **488** at a selectable position along a length of the through-channel **510**. The threaded fastener **488** thus
10 couples the first proximal end **506** of the first spreader **476** to the base **472**, and holds the first proximal end **506** of the first spreader **476** in a first substantially fixed position relative to the base **472**. However, the threaded fastener **488** can hold the first proximal end **506** of the first spreader **476** at various selectable positions along the length of the through-channel **510**, and therefore the first substantially fixed position of
15 the first proximal end **506** of the first spreader **476** relative to the base **472** is adjustable.

At the first distal end **508**, the first spreader **476** defines an elongate through-hole **512** for receiving a fastener **514**. In the embodiment shown, the fastener **514** is a metallic rivet, although it will be appreciated that this fastener may alternatively be a threaded
20 fastener or another fastener, for example.

The second spreader **478** in the embodiment shown is made from a relatively rigid thermoplastic material, and has a second proximal end shown generally at **516** and a second distal end shown generally at **518**. At the second proximal end **516**, the second spreader **478** defines a through-channel **520** for receiving the threaded
25 fastener **494** at a selectable position along a length of the through-channel **520**. The threaded fastener **494** thus couples the second proximal end **516** of the second spreader **478** to the base **472**, and holds the second proximal end **516** of the second spreader **478** in a second substantially fixed position relative to the base **472**. However, the threaded fastener **494** can hold the second proximal end **516** of the

second spreader **478** at various selectable positions along the length of the through-channel **520**, and therefore the second substantially fixed position of the second proximal end **516** of the second spreader **478** relative to the base **472** is adjustable.

5 At the second distal end **518**, the second spreader **478** defines an elongate through-hole **522** for receiving the fastener **514** through an opening **524** in the web **500**.

10 The fin **474** has first and second force transfer elements **526** and **528** having respective proximal ends **530** and **532** and respective distal ends **534** and **536**. The respective proximal ends **530** and **532** of the first and second force transfer elements **526** and **528** are pivotally connected to the first and second laterally opposite side elements **496** and **498** at respective pivots **538** and **540**. The pivots **538** and **540** in the embodiment shown are metallic rivets, although it will be appreciated that other fasteners may alternatively be used, for example. At the respective distal ends **534** and **536**, the first and second force transfer elements **526** and **528** define respective through-holes for receiving the fastener **514**. Thus, the fastener **514** couples and
15 pivotally connects the respective distal ends **534** and **536** of the first and second force transfer elements **526** and **528** to the first and second distal ends **508** and **518** of the first and second spreaders **476** and **478** respectively.

20 When the flipper **470** is not subjected to any deflecting forces, the flipper **470** may be referred to as being undeflected, such that the bottom wall **484** and the top wall **490** of the base **472** are generally parallel to the fin **474**, and the first and second spreaders **476** and **478** are generally planar, and parallel to and spaced apart from, the bottom wall **484**, the top wall **490**, and the fin **474**. When the flipper **470** is undeflected, as shown in Figure **12**, the first and second force transfer elements **526** and **528** are at
25 respective undeflected angles **542** and **544** from the first and second spreaders **476** and **478**.

Referring to Figure **13**, the flipper **470** is shown deflected in response to an upward kick in the direction of the arrow **546** of the user in a fluid such as water (not shown), for example. In response to the upward kick, the fin **474** deflects in a downward

deflection direction longitudinally relative to the base **472** at the first and second hinges **502** and **504** in the direction of the arrow **548**.

5 Because the first spreader **476** is on a same side of the base **472** and the fin **474**, the first proximal end **506** of the first spreader **476** is held in a first substantially fixed position relative to the base **472**, the first distal end **508** of the first spreader **476** is pivotally connected to the respective distal ends **534** and **536** of the first and second force transfer elements **526** and **528**, and the respective proximal ends **530** and **532** of the first and second force transfer elements **526** and **528** are pivotally connected to the first and second laterally opposite side elements **496** and **498** respectively, the first spreader **476** flexes longitudinally in response to the longitudinal deflection of the fin **474** relative to the base **472** and remains generally parallel to and spaced apart from the fin **474**. Thus, in response to the longitudinal deflection of the fin **474** relative to the base **472** in the direction of the arrow **548**, the first distal end **508** of the first spreader **476** moves longitudinally relative to the fin **474** in the direction of the arrow **550**.

15 In response to the longitudinal movement of the first distal end **508** of the first spreader **476** relative to the fin **474** in the direction of the arrow **550**, the first distal end **508** of the first spreader **476** contacts the fastener **514** at a distal end **552** of the elongate through-hole **512**, and urges the fastener **514** in the direction of the arrow **550**. The first spreader **476** thus imposes a force on the first and second force transfer elements **526** and **528** in the direction of the arrow **550** in response to the longitudinal movement of the first distal end **508** of the first spreader **476** relative to the fin **474** in the direction of the arrow **550**, and thus rotates the first and second force transfer elements **526** and **528** about the respective pivots **538** and **540**, thereby spreading the first and second laterally opposite side elements **496** and **498** apart in the respective directions of the arrows **553** and **555** respectively, thereby elastically deforming the web **500** by stretching the web **500** to accommodate the spreading of the first and second laterally opposite side elements **496** and **498**, and thereby changing a lateral shape of the fin **474**.

Accordingly, the first and second force transfer elements **526** and **528** receive and use a force in the direction of the arrow **550**, and imposed by the first distal end **508** of the first spreader **476** in response to the longitudinal movement of the first distal end **508** of the first spreader **476** caused by longitudinal deflection of the fin **474** relative to the base **472** in the direction of the arrow **548**, to spread the first and second laterally opposite side elements **496** and **498** apart in the respective directions of the arrows **553** and **555** respectively, and thereby change a lateral shape of the fin **474**.

Referring to Figures **12** and **13**, in response to movement of the fastener **514** in the direction of the arrow **550**, the fastener **514** moves in the elongate through-hole **522** of the second spreader **478** towards a proximal end **554** of the elongate through-hole **522**, and therefore the second spreader **478** does not obstruct the aforementioned movement of the fastener **514** caused by the first spreader **476**.

Referring to Figure **14**, the flipper **470** is shown deflected in response to a downward kick in the direction of the arrow **556** of the user in a fluid such as water (not shown), for example. In response to the downward kick, the fin **474** deflects in an upward deflection direction longitudinally relative to the base **472** and the first and second hinges **502** and **504** in the direction of the arrow **558**.

Because the second spreader **478** is on a same side of the base **472** and the fin **474**, the second proximal end **516** of the second spreader **478** is held in a second substantially fixed position relative to the base **472**, the second distal end **518** of the second spreader **478** is pivotally connected to the respective distal ends **534** and **536** of the first and second force transfer elements **526** and **528**, and the respective proximal ends **530** and **532** of the first and second force transfer elements **526** and **528** are pivotally connected to the first and second laterally opposite side elements **496** and **498** respectively, the second spreader **478** flexes longitudinally in response to the longitudinal deflection of the fin **474** relative to the base **472** and remains generally parallel to and spaced apart from the fin **474**. Thus, in response to the longitudinal deflection of the fin **474** relative to the base **472** in the direction of the

arrow **558**, the second distal end **518** of the second spreader **478** moves longitudinally relative to the fin **474** in the direction of the arrow **560**.

In response to the longitudinal movement of the second distal end **518** of the second spreader **478** in the direction of the arrow **560**, the second distal end **518** of the second spreader **478** contacts the fastener **514** at a distal end **562** of the elongate through-hole **522**, and thus the second distal end **518** of the second spreader **478** imposes a force on the fastener **514** in the direction of the arrow **560**, thereby rotating the first and second force transfer elements **526** and **528** about the respective pivots **538** and **540** (shown in Figures **12** and **13**), thereby spreading the first and second laterally opposite side elements **496** and **498** apart in the respective directions of the arrows **566** and **568** respectively to change a lateral shape of the fin **474**, and thereby elastically deforming the web **500** by stretching the web **500** to accommodate the spreading of the first and second laterally opposite side elements **496** and **498**.

Accordingly, the first and second force transfer elements **526** and **528** receive and use a force in the direction of the arrow **560**, and imposed by the second distal end **518** of the second spreader **478** in response to the longitudinal movement of the second distal end **518** of the second spreader **478** caused by longitudinal deflection of the fin **474** relative to the base **472** in the direction of the arrow **558**, to spread the first and second laterally opposite side elements **496** and **498** apart in the respective directions of the arrows **566** and **568** respectively, and thereby to change a lateral shape of the fin **474**.

When the fastener **514** moves in the direction of the arrow **560**, the fastener **514** moves in the elongate through-hole **512** of the first spreader **476** to a proximal end **564** of the elongate through-hole **512** (shown in Figures **12** and **13**), and therefore the first spreader **476** does not obstruct the aforementioned movement of the fastener **514** caused by the second spreader **478**.

Referring to Figures **15** and **16**, a flipper in accordance with another embodiment of the invention is shown generally at **570**. The flipper **570** includes a base shown

generally at **572**, first and second laterally opposite side elements **574** and **576**, an elastically deformable web **578**, a spreader **580**, and a curving element **582** coupled to the web **578**.

5 In the embodiment shown, the base **572** is made from a moderately flexible thermoplastic material. The base **572** defines a foot pocket **584** for receiving a foot of a user (not shown), and a heel-retaining strap **586** extending from laterally opposite sides of the base **572** and across an opening of the foot pocket **584** for contacting a heel of the foot to hold the foot in the foot pocket **584**. The base **572** also defines a longitudinal recess **588**, and a transverse cylindrical hole **590** centered about and
10 extending across the longitudinal recess **588** for receiving a pivot **592**.

Referring to Figures **15**, **16**, **17**, and **18**, the first laterally opposite side element **574** is connected to the base **572** by a first hinge **594**, and includes an elongate member defining a channel **596** (shown in Figure **17**) and a recess **598** (shown in Figure **18**). The first laterally opposite side element **574** in the embodiment shown is made from a
15 relatively rigid thermoplastic material. The channel **596** has a relatively narrow opening **600** and a widened inner portion **602** for slidably retaining a bead **604** coupled to the web **578**. The recess **598** includes a first guide shown generally at **606** having a first wall **608** extending at an acute angle **610** from a central longitudinal axis **612** of the flipper **570**. The second laterally opposite side element **576** is connected to
20 the base **572** by a second hinge **614**, and is substantially a mirror image of the first laterally opposite side element **574**. The first and second hinges **594** and **614** are substantially the same as the first and second hinges **132** and **134** respectively discussed above and shown in Figures **1** to **6**, and therefore function in substantially the same way.

25 In the embodiment shown, the base **572**, the first and second laterally opposite side elements **574** and **576**, and the first and second hinges **594** and **614** are unitarily formed in a multi-stage injection moulding process, although alternatively these elements may be formed by other processes.

Referring back to Figures **15** and **16**, the web **578** is made from a relatively flexible thermoplastic material, and as discussed above, includes a bead **604** for being received within the channel **596** of the first laterally opposite side element **574**. The web **578** is also coupled to a corresponding bead **616** for being received within a
5 channel **618** of the second laterally opposite side element **576** corresponding to the channel **596** of the first laterally opposite side element **574**.

Also as discussed above, the web **578** is coupled to the curving element **582**, which in the embodiment shown is made from a relatively rigid thermoplastic material. The curving element **582** is generally arcuate, and includes a longitudinal projection **620** at an apex of the arc and having a transverse cylindrical through-hole **622** for receiving a
10 pivot **624** therethrough.

The spreader **580** in the embodiment shown is made from a relatively rigid thermoplastic material. The spreader **580** is generally arcuate, and has a proximal end shown generally at **626** at an apex of the arc, and a distal end shown generally at **628**.
15 At the proximal end **626**, the spreader **580** includes a longitudinal projection **630** having a transverse cylindrical through-hole **632** for receiving the pivot **592**. At the proximal end **626**, the spreader **580** further defines a longitudinal recess **640**, and a transverse cylindrical hole **642**, centered around and extending across the longitudinal recess **640**, for receiving the pivot **624**.

20 At the distal end **628**, the spreader **580** has first and second pins **634** and **636** on respective opposite spaced apart distal ends of the arc. Because the spreader **580** is made from a relatively rigid thermoplastic material, the spreader **580** maintains the first and second pins **634** and **636** at a generally constant separation distance **638**.

25 When the aforementioned components are assembled as shown in Figure **16**, the longitudinal projection **630** of the spreader **580** is received in the longitudinal recess **588** of the base **572**, and the pivot **592** is received in the transverse cylindrical hole **590** of the base **572** and the transverse cylindrical through-hole **632** of the longitudinal projection **630** of the spreader **580**, and the proximal end **626** of the spreader **580** is

thus pivotally coupled to the base **572** about the pivot **592**. Further, the longitudinal projection **620** of the curving element **582** is received in the longitudinal recess **640** of the spreader **580**, and the pivot **624** is received in the transverse cylindrical through-hole **622** of the longitudinal projection **620** of the curving element **582** and in the transverse cylindrical hole **642** of the spreader **580**, and the curving element **582** is thus pivotally coupled to the spreader **580** about the pivot **624**. As shown in Figure **16**, the curving element **582** extends longitudinally across the first and second hinges **594** and **614**.

Further, when the aforementioned components are assembled as shown in Figure **16**, the first pin **634** is received within the first guide **606** of the first laterally opposed side element **574**, and in slidable contact with the first wall **608** of the first guide **606**. Likewise, the second pin **636** is similarly received in a corresponding recess of the second laterally opposite side element **576**. Still further, the beads **604** and **616** coupled to the web **578** are received within the channels **596** and **618** of the first and second laterally opposite side elements **574** and **576** respectively, and thus the web **578** is coupled to and extends between the first and second laterally opposite side elements **574** and **576**. The first and second laterally opposite side elements **574** and **576** and the web **578** thus assembled may be said to form a fin shown generally at **645**.

When the flipper **570** is not subjected to any deflecting forces, the flipper **570** may be referred to as being undeflected, such that the fin **645**, the spreader **580**, and the curving element **582** are generally coplanar with a bottom wall **646** of the base **572**. The flipper **570** is shown undeflected in Figure **16**.

Referring to Figures **19** and **20**, the flipper **570** is shown deflected in response to a downward kick in the direction of the arrow **648** of the user in a fluid such as water (not shown), for example. In response to the downward kick, the fin **645** deflects in an upward deflection direction longitudinally relative to the base **572** at the first and second hinges **594** and **614** in the direction of the arrow **650**.

5 In the embodiment shown, the first and second hinges **594** and **614** are made from a relatively flexible thermoplastic material, while the first and second laterally opposite side elements **574** and **576** and the spreader **580** are made from relatively rigid thermoplastic materials. Referring to Figure **20**, when the fin **645** deflects in the upward deflection direction longitudinally relative to the base **572** in the direction of the arrow **650**, the first and second hinges **594** and **614** flex longitudinally along a first curve (shown for the second hinge **614** in Figure **20**). However, because the spreader **580** is more rigid than the first and second hinges **594** and **614**, the spreader **580** flexes longitudinally along a second curve (shown in Figure **20**) having a curvature less than a curvature of the first curve. This difference in curvature causes an intermediate portion shown generally at **652** of the spreader **580** to move away from the fin **645** in the direction of the arrow **650** as shown in Figure **20**, and causes longitudinal movement of the distal end **628** of the spreader **580** relative to the fin **645** in the direction of the arrow **654**.

15 Thus, in response to longitudinal deflection of the fin **645** relative to the base **572** in the direction of the arrow **650**, the distal end **628** of the spreader **580** moves longitudinally relative to the fin **645** in the direction of the arrow **654**, and this longitudinal movement causes the first pin **634** to move from a proximal end **656** of the first guide **606** (as shown in Figures **15** and **16**) to a distal end **658** of the first guide **606** (as shown in Figure **19**). Because the first wall **608** (shown in Figures **15** and **18**) is disposed at the acute angle **610** from the central longitudinal axis **612** of the flipper **570** (shown in Figure **15**), the longitudinal movement of the distal end **628** of the spreader **580** in the direction of the arrow **654** causes the first pin **634** to slide along the first wall **608** and impose a thrust force on the first wall **608** in the direction of the arrow **650**. Likewise, this longitudinal movement causes the second pin **636** to slide along a corresponding wall of a corresponding guide on the second laterally opposite side element **576**, and to impose a thrust force on the corresponding wall in the direction of the arrow **650**. These thrust forces from the first and second pins **634** and **636** may collectively be referred to as “a first force”.

Further, because the spreader **580** maintains the generally constant separation distance **638** between the first and second pins **634** and **636**, the first wall **608** and the corresponding wall of the second laterally opposite side element **576** receive and use these respective thrust forces from the first and second pins **634** and **636** in response to this longitudinal movement to cause the first and second laterally opposite side elements **574** and **576** spread apart in the respective directions of the arrows **659** and **661** respectively, thereby changing a lateral shape of the fin **645**, and thereby elastically deforming the web **578** by stretching the web **578** to accommodate the spreading of the first and second laterally opposite side elements **574** and **576**.

The first and second hinges **594** and **614** are substantially the same as the first and second hinges **132** and **134** shown in Figures **1** and **6**, and therefore, as discussed above and shown in Figures **3** to **6**, the first and second hinges **594** and **614** have respective hinge axes that extend away from a central longitudinal axis of the fin **645** and away from the base **572** at respective acute angles from the central longitudinal axis of the fin, thus imparting a concave shape to the fin opposite the direction of longitudinal deflection of the fin **645** relative to the base **572**. However, as shown in Figures **19** and **20**, the intermediate portion **652** of the spreader **580** moves away from the fin **645** in the direction of the arrow **650** when the fin **645** is deflected longitudinally in the direction of the arrow **650** relative to the base **572**. Because the distal end **628** of the spreader **580** is coupled to the first and second laterally opposite side elements **574** and **576** on respective inner sides **660** and **662** of the first and second laterally opposite side elements **574** and **576**, movement of the intermediate portion **652** of the spreader **580** away from the fin **645** imposes respective forces on the inner sides **660** and **662** in substantially the same direction as the direction of the arrow **650**, thereby rotating the first and second laterally opposite side elements **574** and **576** about respective generally longitudinal axes **664** and **666** of the first and second laterally opposite side elements **574** and **576** in the respective directions of the arrows **668** and **670** respectively. This rotation further imparts a concave shape to the fin **645** opposite the deflection direction of the arrow **650**.

Referring to Figure 20, as indicated above, when the fin 645 deflects in the upward deflection direction longitudinally relative to the base 572 in the direction of the arrow 650, the first and second hinges 594 and 614 flex longitudinally along a first curve (shown for the second hinge 614 in Figure 20). However, as indicated above, the curving element 582 is made from a relatively rigid thermoplastic material. Because the curving element 582 is more rigid than the first and second hinges 594 and 614, the curving element 582 has a curvature less than a curvature of the first curve. Therefore, when the first and second hinges 594 and 614 flex longitudinally along the first curve, the curving element 582 moves longitudinally relative to the first and second laterally opposite side elements 574 and 576 in the direction of the arrow 654, for similar reasons that the distal end 628 of the spreader 580 relative to the fin 645 in the direction of the arrow 654. However, the curving element 582 is coupled to the web 578, which is not generally movable longitudinally in the direction of the arrow 654. Therefore, to accommodate the longitudinal movement of the curving element 582 relative to the first and second laterally opposite side elements 574 and 576 in the direction of the arrow 654, the curving element 582 is deflected and rotates longitudinally about the pivot 624 generally in the direction of the arrow 650, as shown in Figure 20. This rotation further imparts a concave shape to the fin 645 opposite the deflection direction of the arrow 650.

Although Figures 19 and 20 show the fin 645 deflected upward in the direction of the arrow 650 relative to the base 572 in response to a downward kick in the direction of the arrow 648, the fin 645 may also be deflected downward in a deflection direction opposite the direction of the arrow 650 relative to the base 572 in response to an upward kick in a direction opposite the direction of the arrow 648. In the case of such downward deflection, the spreader 580 and the curving element 582 move away from the fin 645 generally in the direction opposite the direction the direction of the arrow 650, and the distal end 628 of the spreader 580 still moves in the direction of the arrow 654 relative to the fin 645. Such downward deflection therefore causes the first and second laterally opposite side elements 574 and 576 to spread and change the

lateral shape of the fin **645** in substantially the same way as discussed above and shown in Figures **19** and **20** in the case of upward deflection.

5 Referring to Figures **21** and **22**, a flipper in accordance with another embodiment of the invention is shown generally at **680**. The flipper **680** includes a base shown generally at **682**, first and second laterally opposite side elements **684** and **686**, first and second hinges **688** and **690** coupling the first and second laterally opposite side elements **684** and **686** respectively to the base **682**, an elastically deformable web **692**, a curving element **694** coupled to the web **692**, and a spreader **696**.

10 In the embodiment shown, the base **682** is made from a moderately flexible thermoplastic material. The base **682** defines a foot pocket **698** for receiving a foot of a user (not shown), and a heel-retaining strap **700** extending from laterally opposite sides of the base **682** and across an opening of the foot pocket **698** for contacting a heel of the foot to hold the foot in the foot pocket **698**. The base **682** also includes a longitudinal projection **702** having a longitudinal recess shown generally at **704** at a distal end thereof. The longitudinal projection **702** defines a transverse cylindrical through-hole **706** extending across the longitudinal recess **704** for receiving a pivot **708**. The base **682** also defines a cylindrical transverse through-hole **710** centered about and extending through the longitudinal projection **702** for receiving a pivot **712**.

20 In the embodiment shown, the first and second laterally opposite side elements **684** and **686** are made from a relatively rigid thermoplastic material. Referring to Figures **21**, **22**, and **23**, the first laterally opposite side element has a generally semi-circular recess **714** for receiving a first generally semi-circular projection **716** of the spreader **696**. Likewise, the second laterally opposite side element **686** defines a generally semi-circular recess **718** for receiving a second generally semi-circular projection **720** of the spreader **696**. As shown in Figures **22** and **23**, the first and second generally semi-circular projections **716** and **720** are rotatably received within the generally semi-circular recesses **714** and **718** respectively.

The first and second hinges **688** and **690** are substantially the same as the first and second hinges **132** and **134** described above and shown in Figures **1** to **6**, and therefore function in substantially the same way.

5 In the embodiment shown, the base **682**, the first and second laterally opposite side elements **684** and **686**, and the first and second hinges **688** and **690** are unitarily formed in a multi-stage injection moulding process, although alternatively these elements may be formed by other processes.

10 In the embodiment shown, the web **692** is made from a relatively flexible thermoplastic material. As shown in Figure **22**, the web **692** is coupled to and extends between the first and second laterally opposite side elements **684** and **686**, and as discussed above, the web **692** is also coupled to the curving element **694**.

15 The curving element **694** in the embodiment shown is made from a relatively rigid thermoplastic material, and includes a transverse through-hole **722** for receiving the pivot **708**. Thus as shown in Figure **22**, the curving element **694** is coupled to the base **682** by a generally transverse hinge at the pivot **708**. The curving element **694** also has a transverse through-hole **724** for receiving a transverse pivot **726** of the spreader **696**.

20 The spreader **696** in the embodiment shown is made from a relatively rigid thermoplastic material, and has a proximal end shown generally at **728**, a distal end shown generally at **730**, and an intermediate portion shown generally at **732** between the proximal and distal ends **728** and **730**. At the proximal end **728**, the spreader **696** has a longitudinal recess shown generally at **734** for receiving the longitudinal projection **702** of the base **682**, and the spreader **696** defines a transverse cylindrical through-hole **735** extending across the longitudinal recess **734** for receiving the pivot **712**. As shown in Figure **22**, the proximal end **728** of the spreader **696** is thus coupled to the base **682** by a generally transverse hinge at the pivot **712**.

25

At the distal end **730**, the spreader **696** has the first and second generally semi-circular projections **716** and **720** at respective ends of opposite and spaced apart members of the spreader **696**.

5 At the intermediate portion **732**, the spreader **696** has the transverse pivot **726**, which as discussed above is received in the transverse through-hole **724** of the curving element **694**. As shown in Figure **22**, the curving element **694** is therefore also coupled to the spreader **696** by a generally transverse hinge at the transverse pivot **726** at the intermediate portion **732** of the spreader **696**.

10 When the flipper **680** is assembled as shown in Figure **22**, the first and second laterally opposite side elements **684** and **686** and the web **692** may be said to form a fin shown generally at **736**. As indicated above, the first and second generally semi-circular projections **716** and **720** are rotatably received within the generally semi-circular recesses **714** and **718** respectively of the first and second laterally opposite side elements **684** and **686** respectively, and the distal end **730** of the spreader **696** is thus coupled to the fin **736**.

15 When the flipper **680** is not subjected to any deflecting forces, the flipper **680** may be referred to as being undeflected, such that the curving element **694**, the spreader **696**, and the fin **736** are generally planar with a bottom wall **738** of the base **682**. The flipper **680** is shown undeflected in Figure **22**.

20 Referring to Figures **24** and **25**, the flipper **680** is shown deflected in response to a downward kick in the direction of the arrow **740** of the user in a fluid such as water (not shown), for example. In response to the downward kick, the fin **736** deflects in an upward deflection direction longitudinally relative to the base **682** at the first and second hinges **688** and **690** in the direction of the arrow **742**.

25 In the embodiment shown, the first and second hinges **688** and **690** are made from a relatively flexible thermoplastic material, whereas the first and second laterally opposite side elements **684** and **686** are made from a relatively rigid thermoplastic material. Because the first and second hinges **688** and **690** are more flexible than the

surrounding material, longitudinal deflection of the fin **736** relative to the base **682** in the direction of the arrow **742** causes the first and second hinges **688** and **690** to flex longitudinally along a first curve (shown for the second hinge **690** in Figure **25**).

5 However, as indicated above, the spreader **696** is made from a relatively rigid thermoplastic material. Because the proximal end **728** of the spreader **696** is coupled to the base **682** about the pivot **712**, the distal end **730** of the spreader **696** is coupled to the first and second laterally opposite side elements **684** and **686**, and the spreader **696** is more rigid than the first and second hinges **688** and **690**, longitudinal deflection of the fin **736** in the direction of the arrow **742** causes the spreader **696** to flex
10 longitudinally along a second curve (shown in Figure **25**) having a curvature less than a curvature of the first curve, thereby causing the intermediate portion **732** of the spreader **696** to move away from the fin **736** generally in the direction of the arrow **742** as shown in Figure **25**.

15 Because the spreader **696** curves along a second curve having a curvature less than the curvature of the first curve of the first and second hinges **688** and **690**, the distal end **730** of the spreader **696** is urged longitudinally relative to the fin in the direction of the arrow **744**. Because the first and second generally semi-circular projections **716** and **720** of the spreader **696** are rotatably received within the generally semi-circular recesses **714** and **718** of the first and second laterally opposite side elements **684** and
20 **686** respectively, the longitudinal urging of the distal end **730** of the spreader **696** in the direction of the arrow **744** causes the first and second generally semi-circular projections **716** and **720** to impose respective thrust forces on the first and second laterally opposite side elements respectively in the respective directions of the arrows **746** and **748** respectively shown in Figure **24**. The respective thrust forces thus
25 imposed by the first and second generally semi-circular projections **716** and **720** may collectively be referred to as "a first force".

The respective thrust forces of the first and second generally semi-circular projections **716** and **720** in the directions of the arrows **746** and **748** respectively spread the first and second laterally opposite side elements apart in the respective directions of the

arrows **747** and **749** respectively. Thus, the first and second generally semi-circular projections **716** and **720** are coupled to the first and second laterally opposite side elements **684** and **686** by respective hinges that receive and use the forces imposed by the distal end **730** of the spreader **696** caused by longitudinal deflection of the fin **736** relative to the base **682** to spread the first and second laterally opposite side elements **684** and **686** apart, which elastically deforms the web **692** by stretching the web **692** to accommodate the spreading of the first and second laterally opposite side elements **684** and **686**, and changes a lateral shape of the fin **736**. Although the spreader **696** in the embodiment shown is made from a relatively flexible thermoplastic material, the spreader **696** is flexible enough to permit a separation distance **751** between the first and second generally semi-circular projections **716** and **720** to change as the first and second laterally opposite side elements **684** and **686** are spread apart.

As discussed above, the intermediate portion **732** of the spreader **696** is coupled to the curving element **694** by a generally transverse hinge at the transverse pivot **726** of the spreader **696**. Therefore, when the intermediate portion **732** of the spreader **696** moves away from the fin **736** generally in the direction of the arrow **742** in response to longitudinal deflection of the fin **736** relative to the base **682** in the direction of the arrow **742**, the intermediate portion **732** of the spreader **696** urges the curving element at the transverse through-hole **724** of the curving element **694** away from the fin **736** generally in the direction of the arrow **742**, thus deflecting the curving element about the pivot **708**. As shown in Figure **25**, this deflection of the curving element **694** about the pivot **708** causes the web **692** to move away from the first and second laterally opposite side elements **684** and **686** generally in the direction of the arrow **742**, thereby imparting a concave shape to the fin **736** opposite the deflection direction of the arrow **742**.

Further, the first and second generally semi-circular projections **716** and **720** of the spreader **696** contact the first and second laterally opposite side elements **684** and **686** respectively at respective inner sides **750** and **752** of the first and second laterally opposite side elements **684** and **686**. Therefore, when the intermediate portion **732** of

the spreader **696** moves generally in the direction of the arrow **742**, the distal end **730** of the spreader **696** imposes respective forces generally in the direction of the arrow **742** on the respective inner sides **750** and **752** of the first and second laterally opposite side elements **684** and **686**, thereby causing the first and second laterally opposite side elements **684** and **686** to rotate about respective generally longitudinal axes **754** and **756** of the first and second laterally opposite side elements **684** and **686** in respective directions of arrows **758** and **760** respectively. This rotation of the first and second laterally opposite side elements **684** and **686** further imparts a concave shape to the fin **736** opposite the deflection direction of the arrow **742**.

Although Figures **24** and **25** show the fin **736** deflected upward in the direction of the arrow **742** relative to the base **682** in response to a downward kick in the direction of the arrow **740**, the fin **736** may also be deflected downward in a deflection direction opposite the direction of the arrow **742** relative to the base **682** in response to an upward kick in a direction opposite the direction of the arrow **740**. In the case of such downward deflection, the spreader **696** and the curving element **694** move away from the fin **736** generally in the direction opposite the direction the direction of the arrow **742**. Such downward deflection therefore causes the first and second laterally opposite side elements **684** and **686** to spread and change the lateral shape of the fin **736** in substantially the same way as discussed above and shown in Figures **24** and **25** in the case of upward deflection.

Referring to Figure **26**, a flipper in accordance with another embodiment of the invention is shown generally at **770**. The flipper **770** includes a base shown generally at **772**, first and second laterally opposite side elements **774** and **776**, first and second hinges **778** and **780** coupling the first and second laterally opposite side elements **774** and **776** respectively to the base **772**, an elastically deformable web **782**, a curving element **784** coupled to the web **782**, a spreader **786**, and pivots **788** and **790**. The flipper **770** is substantially the same as the flipper **680** discussed above and shown in Figures **21** to **25**, although the flipper **770** further includes first and second elastomeric members **792** and **794** for hingedly coupling the first and second laterally opposite side elements **774** and **776** respectively to a distal end shown generally at **796** of the

spreader **786**. In the embodiment shown, the first and second elastomeric members **792** and **794** are made from a relatively flexible thermoplastic material. The flipper **770** may be formed using multi-stage injection moulding, for example.

5 More particularly, respective proximal ends **798** and **800** of the first and second elastomeric members **792** and **794** are coupled to respective distal ends **802** and **804** of respective spaced apart elongate members **806** and **808** of the spreader **786** at the distal end **796** of the spreader **786**. Also, respective distal ends **810** and **812** of the first and second elastomeric members **792** and **794** are received in respective recesses shown generally at **814** and **816** of the first and second laterally opposite side elements **774** and **776**, and coupled to the first and second laterally opposite side elements **774** and **776** respectively at the respective recesses **814** and **816**. The first and second elastomeric members **792** and **794** thus hingedly couple the distal end **796** of the spreader **786** to the first and second laterally opposite side elements **774** and **776** respectively, and the flipper **770** thus functions substantially the same as the flipper **680** discussed above and shown in Figures **21** to **25**.

Referring to Figures **27** and **28**, a flipper in accordance with another embodiment of the invention is shown generally at **820**. The flipper **820** includes a base shown generally at **822**, first and second laterally opposite side elements **824** and **826**, and an elastically deformable web **828** coupled to and extending between the first and second laterally opposite side elements **824** and **826**.

In the embodiment shown, the base **822** is made from a moderately flexible thermoplastic material. The base **822** defines a foot pocket **830** for receiving a foot of a user (not shown), and a heel-retaining strap **832** extending from laterally opposite sides of the base **822** and across an opening of the foot pocket **830** for contacting a heel of the foot to hold the foot in the foot pocket **830**.

The base **822** in the embodiment shown is unitarily formed (by multi-stage injection moulding, for example) with a spreader shown generally at **834**. The spreader **834** in the embodiment shown is made from a relatively rigid thermoplastic material. The

spreader **834** has a proximal end **836** coupled to the base **822**, and a distal end shown generally at **838**. At the distal end **838**, the spreader **834** defines recesses shown generally at **840**, **842**, and **844** for receiving complementary projections **846**, **848**, and **850** respectively on the first laterally opposite side element **824**, and
5 recesses shown generally at **852**, **854**, and **856** for receiving complementary projections **858**, **860**, and **862** respectively of the second laterally opposite side element **826**.

Also at the distal end **838**, the spreader **834** defines a cylindrical hole **864** extending across the recesses **840**, **842**, and **844** for receiving a pivot **866**. Further, at the distal end **838**, the spreader **834** defines a cylindrical hole **868** extending across the recess
10 **844** for receiving a pivot **870**. Still further, at the distal end **838**, the spreader **834** defines a cylindrical hole **872** extending across the recesses **852**, **854**, and **856** for receiving a pivot **874**. Still further, at the distal end **838**, the spreader **834** defines a cylindrical hole **876** extending across the recess **856** for receiving a pivot **878**. In the
15 embodiment shown, the pivots **866**, **870**, **874**, and **878** are metallic, although alternatively the pivots **866**, **870**, **874**, and **878** may include other materials.

In the embodiment shown, the first and second laterally opposite side elements **824** and **826** are made from relatively rigid thermoplastic materials. The first laterally opposite side element **824** defines a through-hole **880** across the projections **846**,
20 **848**, and **850** for receiving the pivot **866**. As shown in Figure **28**, the first laterally opposite side element **824** is thus coupled to the base **822** and to the distal end **838** of the spreader **834** at a first hinge by the pivot **866**. The second laterally opposite side element **826** defines a through-hole **882** across the projections **858**, **860**, and **862** for receiving the pivot **874**. As shown in Figure **28**, the second laterally opposite side
25 element **826** is thus coupled to the base **822** and to the distal end **838** of the spreader **834** at a second hinge by the pivot **874**.

Referring to Figure **29**, the projection **850** of the first laterally opposite side element **824** has a distal end **884** defining a channel **886** partially enclosed by end walls **888**

and **890** but open at an opening **892**. The projection **862** of the second laterally opposite side element **826** defines a similar channel **894** shown in Figures **27** and **28**.

5 Referring to Figures **27** to **29**, the flipper **820** further includes a first resilient element **896**, which in the embodiment shown is made from a relatively flexible and resilient thermoplastic material. The first resilient element **896** defines a through-hole **898** for receiving the pivot **870**, and the first resilient element **896** is thus pivotally coupled to the pivot **870**. The first resilient element **896** also defines a bead **900** receivable in the channel **886** of the projection **850** of the first laterally opposite side element **824** to couple the first resilient element **896** to the projection **850** of the first laterally opposite side element **824**. The flipper **820** also includes a second resilient element **902** that is coupled in substantially the same way to the pivot **878** and to the channel **894** of the projection **862** of the second laterally opposite side element **826**.

15 Referring to Figure **28**, the web **828** is coupled to and extends between the first and second laterally opposite side elements **824** and **826**. The web **828** and the first and second laterally opposite side elements **824** and **826** may be unitarily formed by multi-stage injection moulding, for example. The first and second laterally opposite side elements **824** and **826** and the web **828** thus coupled or unitarily formed may be referred to as a fin shown generally at **904**.

20 When the flipper **820** is not subjected to any deflecting forces, the flipper **820** may be referred to as being undeflected, such that the first and second laterally opposite side elements **824** and **826** and the web **828** are generally coplanar.

25 However, referring to Figure **30**, the flipper **820** is shown deflected in response to an upward kick in the direction of the arrow **906** of the user in a fluid such as water (not shown), for example. In response to the upward kick, the fin **904** deflects in a downward deflection direction longitudinally relative to the base **822** about the pivot **866** and **874** (shown in Figures **27** and **28**) in the direction of the arrow **908**.

Referring back to Figure **28**, the cylindrical holes **864** and **872** hold the pivots **866** and **874** respectively at respective acute angles **910** and **912** from a central longitudinal

axis **914** of the fin **904**. Therefore, the first and second laterally opposite side elements are coupled to the base **822** and to the distal end **838** of the spreader **834** at first and second hinges, the first and second hinges having respective hinge axes defined by the pivots **866** and **874** respectively and disposed at the respective acute angles **910** and **912** from the central longitudinal axis **914** of the fin **904**.

However, referring back to Figure **30**, the longitudinal deflection of the fin **904** relative to the base **822** tends naturally to involve rotation of the first and second laterally opposite side elements **824** and **826** about a generally transverse axis (not shown) of the fin **904**. Therefore, the distal end **838** of the spreader **834** exerts forces on the first and second laterally opposite side elements **824** and **826** in response to longitudinal deflection of the fin **904** relative to the base **822** to conform the movement of the first and second laterally opposite side elements **824** and **826** about the respective hinge axes defined by the pivots **866** and **874** respectively.

More particularly, in response to the downward deflection of the fin **904** relative to the base **822** in the deflection direction of the arrow **908**, the distal end **838** of the spreader **834** exerts an inward force in the direction of the arrow **911** on the outermost projection **846** of the first laterally opposite side element **824**, and an outward force in the direction of the arrow **913** on the innermost projection **850** of the first laterally opposite element **824**. Also, in response to the downward deflection of the fin **904** relative to the base **822** in the deflection direction of the arrow **908**, the distal end **838** of the spreader **834** exerts an inward force in the direction of the arrow **915** on the outermost projection **858** of the second laterally opposite side element **826**, and an outward force in the direction of the arrow **916** on the innermost projection **862** of the second laterally opposite side element **826**.

The aforementioned forces imposed by the distal end **838** of the spreader **834** may collectively be referred to as “a first force”, and spread the first and second laterally opposite side elements **824** and **826** apart in respective directions of the arrows **917** and **919**. Therefore, the projections **846**, **848**, and **850** of the first laterally opposite side element **824** and the projections **858**, **860**, and **862** of the second laterally

opposite side element **826** use forces imposed by the distal end **838** of the spreader **834**, in response to longitudinal deflection of the fin **904** relative to the base **822**, to spread the first and second laterally opposite side elements **824** and **826** apart, thereby elastically deforming the web **828** by stretching the web **828** to accommodate
5 the separation of the first and second laterally opposite side elements **824** and **826**, and thereby changing a lateral shape of the fin **904**.

Further, because the respective hinge axes defined by the pivots **866** and **874** are at the respective acute angles **910** and **912** from the central longitudinal axis **914** of the fin **904** (shown in Figure **28**), rotation of the first and second laterally opposite side
10 elements about these hinge axes imparts a concave shape to the fin opposite a direction of deflection of the fin, in substantially the same way as described above and illustrated in Figures **3** to **6**.

Because the first and second resilient elements **896** and **902** are coupled to the base **822** and to the projections **850** and **862** respectively of the first and second laterally
15 opposite side elements **824** and **826** respectively, rotating the first and second laterally opposite side elements **824** and **826** about the respective hinge axes defined by the pivots **866** and **874** respectively (shown in Figures **27** and **28**) causes resilient deformation of the first and second resilient elements **896** and **902**, thereby storing elastic potential energy in the first and second resilient elements **896** and **902** and
20 imparting elastic resistance to the fin **904** in response to longitudinal deflection of the fin **904** relative to the base **822**. This elastic potential energy is usable to restore the first and second laterally opposite side elements **824** and **826** from deflected positions shown in Figure **30**, for example, to undeflected positions shown in Figure **28**.

In the embodiment shown, the first and second resilient elements **896** and **902** may be
25 replaced by removing the first and second resilient elements **896** and **902** from the pivots **870** and **878** respectively, and from the channels **886** and **894** (shown in Figures **27** to **29**). Therefore, first and second resilient elements **896** and **902** may be replaced with other resilient elements having different moduli of elasticity, thereby

advantageously enabling adjustment of the elastic resistance of the fin **904** to longitudinal deflection of the fin **904** relative to the base **822**.

Although Figure **30** shows the fin **904** deflected downward in the direction of the arrow **908** relative to the base **822** in response to an upward kick in the direction of the arrow **906**, the fin **904** may also be deflected upward in a deflection direction opposite the direction of the arrow **908** relative to the base **822** in response to a downward kick in a direction opposite the direction of the arrow **906**. Such upward deflection therefore causes the first and second laterally opposite side elements **826** and **826** to spread and change the lateral shape of the fin **904** in substantially the same way as discussed above and shown in Figure **30** in the case of downward deflection.

Referring to Figure **31**, a flipper in accordance with another embodiment of the invention is shown generally at **920**. The flipper **920** includes a base shown generally at **922**, first and second laterally opposite side elements **924** and **926**, first and second hinges **928** and **930** coupling the first and second laterally opposite side elements respectively to the base **922**, first and second resilient elements **932** and **934** coupled to first and second projections **936** and **938** respectively of the first and second laterally opposite side elements **924** and **926** respectively, and pivots **940** and **942** pivotally coupling the first and second resilient elements **932** and **934** respectively to the base **922**.

The flipper **920** is substantially the same as the flipper **820** discussed above and shown in Figures **28** to **30**, except that the first and second hinges **928** and **930** of the flipper **920** are made of a relatively flexible thermoplastic material, and hingedly couple the first and second laterally opposite side elements **924** and **926** to the base **922** such that the flipper **920** functions in substantially the same way as the flipper **820** described above and shown in Figures **27** to **30**. The flipper **920** may be unitarily formed by multi-stage injection moulding, for example.

Referring to Figure **40**, a flipper in accordance with another embodiment of the invention is shown generally at **1090**. The flipper **1090** includes a base shown

generally at **1092**, first and second laterally opposite side elements **1094** and **1096**, and first and second hinges **1098** and **1100** coupling the first and second laterally opposite side elements **1094** and **1096** respectively to the base **1092**. The flipper **1090** also includes an elastically deformable web **1102** coupled to and extending
5 between the first and second laterally opposite side elements **1094** and **1096**.

In the embodiment shown, the elastically deformable web **1102** is detached from the base **1092**, leaving a gap shown generally at **1103** between the base **1092** and the elastically deformable web **1102**. The gap **1103** permits the fin comprised of the first and second laterally opposite side elements **1094** and **1096** and the elastically
10 deformable web **1102** to form a thrust channel along substantially the entire length of the fin when the fin is deflected longitudinally relative to the base **1092**, and such a longer thrust channel may advantageously increase efficiency of the flipper **1090** in generating thrust. However, in alternative embodiments, the elastically deformable web **1102** may be attached to the base **1092**.

15 In the embodiment shown, the base **1092** is made from a moderately flexible thermoplastic material. The base **1092** defines a foot pocket shown generally at **1104** for receiving a foot of a user (not shown), and a heel-retaining strap **1106** extending from laterally opposite sides of the base **1092** and across an opening of the foot pocket **1104** for contacting a heel of the foot to hold the foot in the foot pocket **1104**.

20 The base **1092** in the embodiment shown is unitarily formed (by multi-stage injection moulding, for example) with a spreader shown generally at **1108**. The spreader **1108** in the embodiment shown is made from a relatively rigid thermoplastic material. The spreader **1108** has a proximal end shown generally at **1110** and coupled to the base **1092**, and a distal end shown generally at **1112**. At the distal end **1112**, the spreader
25 **1108** is coupled to the hinges **1098** and **1100**.

Referring to Figure **41**, the hinge **1098** is made from a relatively flexible thermoplastic material. The embodiment shown includes a tapered member **1114** coupling the hinge **1098** to the distal end **1112** of the spreader **1108**, and a tapered member **1116**

coupling the hinge **1098** to the first laterally opposite side element **1094**. In the embodiment shown, the tapered members **1114** and **1116** are made from a relatively rigid thermoplastic material. The tapered member **1114** has tapered outer surfaces **1118** and **1120** extending between the hinge **1098** and the distal end **1112** of the spreader **1108**, and the tapered member **1116** has tapered outer surfaces **1122** and **1124** extending between the hinge **1098** and the first laterally opposite side element **1094**.

Thus, if the first laterally opposite side element **1094** is deflected upward in the direction of the arrow **1126** in response to a downward kick in a fluid such as water (not shown) for example, the tapered outer surfaces **1118** and **1122** make contact to prevent further deflection in the direction of the arrow **1126**. Similarly, if the first laterally opposite side element **1094** is deflected downward in the direction of the arrow **1128** in response to an upward kick in a fluid such as water (not shown) for example, the tapered surfaces **1120** and **1124** may contact to prevent further deflection in the direction of the arrow **1128**. Thus, angles of the tapered surfaces **1118**, **1120**, **1122**, and **1124** may be chosen to define a maximum amount of deflection of the flipper **1090**. Advantageously, such a maximum amount of deflection may maintain a desirable deflected shape of the flipper **1090** to prevent a loss of thrust that may result from excessive deflection, for example. In the embodiment shown, the hinge **1100** is substantially the same as the hinge **1098**, and is coupled to tapered members similar to the tapered members **1114** and **1116**. However, in alternative embodiments, the tapered members **1114** and **1116** may be omitted so that deflection of the flipper **1090** is generally less restricted. More generally, other embodiments described herein for example, hinges may or may not restrict deflection to predetermined maximum amounts of deflection.

Referring to Figure **42**, the elastically deformable web **1102** in the embodiment shown includes a first longitudinal curve **1130** projecting out of a bottom side **1132** of the elastically deformable web **1102**, and second and third longitudinal curves **1134** and **1136** projecting out of a top side **1138** opposite the bottom side **1132** of the elastically deformable web **1102**. In general, the shape and other physical properties of the

elastically deformable web **1102** of a fin may be varied in various embodiments such as the embodiments disclosed herein for example, may be varied to vary the curvature and spreading of the fins. For example, a web that is relatively rigid or less stretchable will permit generally less lateral spreading than a more flexible or stretchable web. In embodiments such as the flipper **1090** and other embodiments disclosed herein for example, longitudinal deflection and lateral spreading both result from rotation of first and second laterally opposite side elements (**1094** and **1096** in the embodiment shown) about hinges (**1098** and **1100** in the embodiment shown), and therefore, in such embodiments, a more stretchable web generally permits more longitudinal deflection. Therefore, a relatively more flexible web may be chosen to permit relatively greater degrees of longitudinal deflection, and a relatively more rigid web may be chosen to permit relatively less deflection, for example.

Referring to Figure **32**, a flipper in accordance with another embodiment of the invention is shown generally at **950**. The flipper **950** includes a base shown generally at **952**, a deformable fin shown generally at **954**, and a spreader **956**.

In the embodiment shown, the base **952** is made from a moderately flexible thermoplastic material. The base **952** defines a foot pocket **958** for receiving a foot of a user (not shown), and a heel-retaining strap **960** extending from laterally opposite sides of the base **952** and across an opening of the foot pocket **958** for contacting a heel of the foot to hold the foot in the foot pocket **958**. Further, referring to Figures **32** and **33**, the base **952** also has a distal end wall **962** defining transverse generally semi-cylindrical channels **964** and **966** for receiving corresponding generally semi-cylindrical transverse projections **968** and **970** respectively on the spreader **956**.

The fin **954** in the embodiment shown includes first and second laterally opposite side elements **972** and **974** and an elastically deformable web **976** coupled to and extending between the first and second laterally opposite side elements **972** and **974**. In the embodiment shown, the first and second laterally opposite side elements **972** and **974** are made from a relatively rigid thermoplastic material, and the web **976** is made from a relatively flexible thermoplastic material. The first and second laterally

opposite side elements **972** and **974** are coupled to the base **952** by first and second hinges **978** and **980**, and the first and second hinges **978** and **980** are substantially the same as the first and second hinges **132** and **134** discussed above and shown in Figures 1 to 6. The base **952**, the first and second laterally opposite side elements **972** and **974**, the web **976**, and the first and second hinges **978** and **980** may be unitarily formed by multi-stage injection moulding, for example.

Referring to Figures **32** and **33**, the spreader **956** in the embodiment shown is made from a relatively rigid thermoplastic material, and has a proximal end shown generally at **982** and a distal end shown generally at **984**. At the proximal end **982**, the spreader **956** has a generally rectangular proximal wall **986** that defines the projections **968** and **970** discussed above. When one or both of the projections **968** and **970** are received in one or both of the channels **964** and **966** respectively of the base **952**, the proximal end **982** of the spreader **956** is thus coupled to the base **952**.

The spreader **956** also has first and second generally parallel and spaced apart walls **988** and **990** extending away from the proximal wall **986** opposite the projections **968** and **970**. The walls **988** and **990** define respective openings that receive a fastener **992**. In the embodiment shown, the fastener **992** is a metallic rivet, although it will be appreciated that this fastener may alternatively be a threaded fastener or another fastener, for example.

Referring to Figure **33**, the first and second laterally opposite side elements **972** and **974** also define respective through-holes (not shown) for receiving the fastener **992**, and the first and second laterally opposite side elements **972** and **974** are thus pivotally coupled to the distal end **984** of the spreader **956**.

When the flipper **950** is not subjected to any deflecting forces, the flipper **950** may be referred to as being undeflected, such that the projections **968** and **970** at the proximal end **982** of the spreader **956** are both received within respective channels **964** and **966** in the distal end wall **962** of the base **952**, and the fin **954** is generally coplanar with a bottom wall **993** of the base **952**.

Referring to Figure 34, the flipper 950 is shown deflected in response to a downward kick in the direction of the arrow 994 of the user in a fluid such as water (not shown), for example. In response to the downward kick, the fin 954 deflects in an upward deflection direction longitudinally relative to the base 952 at the first and second hinges 978 and 980 in the direction of the arrow 996. This longitudinal deflection of the fin 954 causes the first and second laterally opposite side elements 972 and 974 to rotate about the first and second hinges 978 and 980 respectively.

Further, the first and second laterally opposite side elements 972 and 974 are coupled to the fastener 992 such that longitudinal deflection of the fin 954 relative to the base 952 in the deflection direction of the arrow 996 causes the spreader 956 to rotate about a hinge axis defined by the projection 968 and the channel 964, while the projection 970 moves away from the channel 966, as shown in Figures 34 and 35. The hinge axis defined by the projection 968 and the channel 964 lies in a plane shown by the line 998 in Figure 35. This plane is parallel to and spaced apart from a plane intersecting a longitudinal axis 1000 of the fin 954 when the fin 954 is undeflected.

Because of the separation between the respective planes shown by the lines 998 and 1000 in Figure 35, the distal end 984 of the spreader 956 moves longitudinally relative to the fin 954 and away from the base 952 in the direction of the arrow 1002 when the spreader 956 is rotated about the hinge axis defined by the projection 968 and the channel 964 in response to longitudinal deflection of the fin 954 relative to the base 952 in the deflection direction of the arrow 996. This longitudinal movement of the distal end 984 of the spreader 956 in the direction of the arrow 1002 causes the distal end 984 of the spreader 956 to impose a force using the fastener 992 on the first and second laterally opposite side elements 972 and 974 in the direction of the arrow 1002. The first and second laterally opposite side elements 972 and 974 receive and use this force, which causes the first and second laterally opposite side elements 972 and 974 to rotate laterally about the first and second hinges 978 and 980 respectively in respective directions of the arrows 1004 and 1006 respectively, thereby spreading the first and second laterally opposite side elements 972 and 974 apart, elastically

deforming the web **976** by stretching the web **976** to accommodate the spreading of the first and second laterally opposite side elements **972** and **974**, and changing a lateral shape of the fin **954**.

5 Although Figures **34** and **35** show the fin **954** deflected upward in the direction of the arrow **996** relative to the base **952** in response to a downward kick in the direction of the arrow **994**, the fin **954** may also be deflected downward in a deflection direction opposite the direction of the arrow **996** relative to the base **952** in response to an upward kick in a direction opposite the direction of the arrow **994**. In the case of such downward deflection, the spreader **956** rotates about a hinge defined by the projection **970** and the channel **966**, and the projection **968** moves away from the channel **964**.
10 Such downward deflection therefore causes the first and second laterally opposite side elements **972** and **974** to spread and change the lateral shape of the fin **954** in substantially the same way as discussed above and shown in Figures **34** and **35** in the case of upward deflection.

15 In general, the aforementioned flippers **100**, **240**, **350**, **400**, **470**, **570**, **680**, **770**, **820**, **920**, **950**, and **1090** have respective fins that are longitudinally deflectable relative to respective bases, and these fins advantageously spread laterally in response to such longitudinal deflection. Therefore, when one of the aforementioned flippers is not deflected in response to a kick, such as when a user of the flipper is coasting through
20 water, for example, a lateral width of the flipper is relatively small and the fin is relatively planar, which may advantageously reduce drag of the flipper in the water.

However, when the user kicks up or down with the flipper in the water, the fin spreads to a relatively greater width, which may advantageously increase an effective surface area of the fin, which may increase efficiency of propulsion of the user in the water. As
25 the user kicks with greater force, the fin is deflected by a greater degree, and spread laterally by a greater degree, and therefore the fin advantageously adapts to a degree of strength of the user's kick. Further, when the user kicks up or down with the flipper, the flipper tends to impart a concave shape to the fin in the direction of the kick. The fin thus forms a thrust channel, which in many embodiments alternates

advantageously to face the kick direction. This concave shape may prevent water in the kick path of the fin from passing over lateral sides of the fin, and may facilitate directing water in the kick path of the fin towards a distal end of the fin. This concave shape may therefore advantageously facilitate more efficient flow of water around the fin. Further, such a thrust channel can form and capture a fluid vortex, thereby permitting efficient generation of thrust in the fluid. Still further, the concave shape of the fin that results from longitudinal deflection of the fin creates a relatively longitudinally long thrust channel when compared to flippers that do not actively form such concavity. Such a long thrust channel may advantageously capture a larger amount of fluid, thereby more efficiently generating thrust in the fluid. Further, creation of such a relatively long thrust channel makes more efficient use of the fin, and thus may advantageously permit the fin to be smaller or lighter, or both. Again, the flipper imparts a greater degree of concavity in response to a greater strength of kick, and again the fin advantageously adapts to a degree of strength of the user's kick.

Further, flippers such as those described herein may advantageously form a concave shape to form a thrust channel at an early stage of a kick when the fin is longitudinally deflected relative to the base by a relatively small amount. However, further longitudinal deflection of the fin relative to the base may cause the fin to spread laterally, thereby reducing concavity in the fin. Such reduced concavity in the fin advantageously urges fluid from the thrust channel towards a distal end of the fin, thereby more efficiently generating thrust.

In general, flippers such as those described herein have been found to generate thrust significantly more efficiently than some know flippers.

Further, the aforementioned flippers are advantageously adjustable in numerous ways. For example, the relative flexibilities of the spreaders **106, 246, 356, 406, 476, 478, 580, 696, and 786** may be varied to vary a degree of spreading or concavity that results from a kick by a user, and these flexibilities can thus be advantageously adjusted to accommodate the user's kicking strength. For example, a user with relatively strong legs might generally prefer relatively less-flexible spreaders to avoid

- causing excessive spreading or concavity, while a user with relatively less-strong legs might generally prefer relatively more-flexible spreaders that would generally cause relatively higher degrees of spreading and concavity in response to relatively weaker kicks. Still further, the substantially fixed positions of the spreaders **406**, **476**, and **478** can be adjusted to adjust degrees of spreading and concavity of the respective fins, and moduli of elasticity of the first and second elastomeric members **792** and **794**, or of the resilient elements **896**, **902**, **932**, and **934**, can also be adjusted to adjust degrees of spreading and concavity of the respective to accommodate the user's kicking strength, for example.
- Although the bases **102**, **242**, **352**, **402**, **472**, **572**, **682**, **772**, **822**, **922**, **952** in the embodiments shown are configured to receive and hold a foot of a user, these bases may alternatively be configured to connect to a foot-holding boot (as described below and shown in Figures **38** and **39**, for example), or to connect to a prosthetic limb or other source of propulsive force, for example.
- Referring to Figure **36**, a flipper in accordance with another embodiment of the invention is shown generally **1010**. The flipper **1010** has a fin shown generally at **1012** and a foot coupling portion shown generally at **1014**. The fin **1012** may be any fin usable to generate propulsion in water, including any one of the aforementioned fins shown in Figures **1** to **35** and **40** to **42**, for example.
- The foot coupling portion **1014** includes a boot contacting surface **1016** for contacting a sole of a boot, and a boot connector **1018** on the boot contacting surface **1016**. The boot connector **1018** includes an elongate portion **1020** having a generally rectangular cross section, and defining an elongate through-channel **1022** for receiving a threaded fastener **1024**. The foot coupling portion **1014** has an opening (not shown) in the boot contacting surface **1016** in communication with a threaded receptacle (not shown) in the foot coupling portion **1014** for threadedly holding the threaded fastener **1024** at a selectable position along the length of the elongate through-channel **1022**. The boot connector **1018** is thus adjustably positionable on the boot contacting surface **1016** by

adjusting a position of the threaded fastener **1024** in the elongate through-channel **1022**.

5 The foot coupling portion **1014** has a first end shown generally at **1023**, and at the first end **1023**, the foot coupling portion **1014** has a holder **1025** (which may also be referred to more generally as a “first connector”) extending from laterally opposite sides of the foot coupling portion **1014** and over the boot contacting surface **1016**. In the embodiment shown, the holder **1025** is a metallic bar, although it will be appreciated that alternatively other materials may be used.

10 The foot coupling portion **1014** also has a second end shown generally at **1026**. At the second end **1026** of the foot coupling portion **1014**, the boot connector **1018** includes a clasp **1028** (which may also be referred to more generally as a “second connector”) above the boot contacting surface **1016** and projecting towards the first end **1023** of the foot coupling portion **1014**. The boot connector **1018** also includes a handle **1030** proximate the clasp **1028** to facilitate positioning the clasp **1028**.

15 Referring to Figure **37**, a boot shell in accordance with another embodiment of the invention is shown generally at **1040**. The boot shell **1040** in the embodiment shown is made from a relatively rigid thermoplastic material. The boot shell **1040** includes a foot holding portion **1042** having a first end (or, more generally, a “first region”) shown generally at **1044** and a second end (or, more generally, a “second region”) shown
20 generally at **1046**. In the embodiment shown, the first end **1044** is opposite, or more generally spaced apart from, the second end **1046**. At the first end **1044**, the foot holding portion **1042** of the boot shell **1040** defines a first receptacle shown generally at **1048** that is complementary to the holder **1025** shown in Figure **36** for receiving the holder **1025**. The holder **1025** and the first receptacle **1048** are thus complementary
25 connectors. Further, at the second end **1046** the foot holding portion **1042**, the boot shell **1040** defines a second receptacle shown generally at **1050** that is complementary to the clasp **1028** shown in Figure **36** for receiving the clasp **1028**. The clasp **1028** and the second receptacle **1050** are thus complementary connectors. The boot shell **1040** also includes an ankle stabilizer **1052** rotatably coupled to the

foot holding portion **1042** at a hinge shown generally at **1054**. The foot holding portion **1042** also has a sole **1082** that defines a longitudinal channel shown generally at **1083**.

5 Referring to Figure **38**, a boot in accordance with another embodiment of the invention is shown generally at **1060**. The boot **1060** includes the boot shell **1040** shown in Figure **37**, and further includes a liner **1062** made from a material such as neoprene, for example. The liner **1062** in the embodiment shown is removable from the boot shell **1040**, but alternatively the liner **1062** and the boot shell **1040** may be integrally formed. Also, the boot shell **1040** may alternatively hold a foot of a user without the
10 liner **1062**, for example.

In use, a user may position the liner **1062** around a foot of the user, fastening the liner **1062** to the foot with a zipper or other fastener (not shown), for example. The liner **1062** is received within the boot shell **1040** such that a foot in the liner **1062** is held in the foot holding portion **1042** of the boot shell **1040**. A strap **1064** received through an
15 opening **1066** in the boot shell **1040** facilitates holding the liner **1062** in the foot holding portion **1042** of the boot shell **1040**. Further, a strap **1068** passes through openings **1070** and **1072** in the ankle stabilizer **1052** of the boot shell **1040** to fasten an ankle within the liner **1062** to the ankle stabilizer **1052**. Because the ankle stabilizer **1052** is rotatable about the hinge **1054**, the ankle stabilizer **1052** may advantageously
20 permit flexion and extension of an ankle (not shown) in the liner **1062** and in the boot shell **1040** while preventing pronation or supination of the ankle, for example.

Referring to Figure **39**, a boot-flipper system in accordance with another embodiment of the invention is shown generally at **1080**. The system **1080** includes the flipper **1010** shown in Figure **36** and the boot **1060** shown in Figure **38**. The sole **1082** of the
25 foot holding portion **1042** contacts the boot contacting surface **1016** of the flipper **1010**, and the elongate portion **1020** of the boot connector **1018** is received within the longitudinal channel **1083** of the foot holding portion **1042** to prevent lateral movement of the foot holding portion **1042** relative to the foot coupling portion **1014**. Further, the holder **1025** of the flipper **1010** is received within the first receptacle **1048** of the foot

holding portion **1042**, and the clasp **1028** of the flipper **1010** is received in the second receptacle **1050** of the foot holding portion **1042**. The boot-flipper system **1080** thus facilitates coupling a foot (not shown) in the foot holding portion **1042** to the flipper **1010**. As indicated above, the ankle stabilizer **1052** permits flexion and extension of an ankle (not shown) in the liner **1062** and in the boot shell **1040** while preventing pronation or supination of the ankle, and therefore the boot-flipper system **1080** may advantageously offer a user a high degree of control over movement of the fin **1012** of the flipper **1010** coupled to the boot **1060**.

The boot-flipper system **1080** facilitates coupling a foot to the flipper **1010** in the foot holding portion **1042**, and a user may select a boot such as the boot **1060** but having a foot holding portion such as the foot holding portion **1042** that comfortably fits a foot of the user. Advantageously, the user can select such a boot independently of a flipper such as the flipper **1010**, and therefore with one such boot, the user may use any flipper such as the **1010** while advantageously using the boot selected to fit the user's foot comfortably.

Referring to Figure **43**, a flipper in accordance with another embodiment of the invention is shown generally at **1140**. The flipper **1140** has a fin shown generally at **1142** and a foot coupling portion shown generally at **1144**. The fin **1142** may be any fin usable to generate propulsion in water, including any one of the aforementioned fins shown in Figures **1** to **35** and **40** to **42**, for example.

The foot coupling portion **1144** has a first end shown generally at **1146** and a second end shown generally at **1148** opposite the first end **1146**. The foot coupling portion **1144** defines a first inward projection **1150** on the first end **1146**, and a second inward projection **1152** on the second end **1148**. The first and second inward projections **1150** and **1152** are spaced apart by a gap shown generally at **1154**, and the gap **1154** is an opening to a recess **1156** in the foot coupling portion **1144**.

Referring to Figure **44**, a boot shell in accordance with another embodiment of the invention is shown generally at **1160**. The boot shell **1160** is made from a relatively

rigid thermoplastic material and includes a foot holding portion shown generally at **1162**. The foot holding portion **1162** has a front end shown generally at **1164**, and the front end **1164** has a top side shown generally at **1166** and a bottom side shown generally at **1168**. In a first region shown generally at **1170** on the top side **1166** of the front end **1164** of the foot holding portion **1162**, the boot shell **1160** defines a first receptacle shown generally at **1172** complementary to the first inward projection **1150** of the flipper **1140** (shown in Figure **43**). Also, in a second region shown generally at **1174** on the bottom side **1168** of the front end **1164** of the foot holding portion **1162**, the boot shell **1160** defines a second receptacle shown generally at **1176** complementary to the second inward projection **1152** of the flipper **1140** (shown in Figure **43**).

Referring to Figures **43** and **44**, in operation, a user may insert a liner (such as the liner **1062** shown in Figure **38**, for example) in the boot shell **1160**, and the user may connect the flipper **1140** to the boot shell **1160** by receiving the first inward projection **1150** in the first receptacle **1172** and by receiving the second inward projection **1152** in the second receptacle **1176**. The first and second inward projections **1150** and **1152** thus function as connectors, clasps, and holders, and the first and second receptacles **1172** and **1176** thus function as connectors, for connecting the flipper **1140** to a boot including the boot shell **1160**. In the embodiment shown, the foot coupling portion **1144** is made from a relatively rigid but deformable thermoplastic material, so that the boot coupling portion **1144** may be temporarily deformed to connect the flipper **1140** to a boot including the boot shell **1160** as described above.

While specific embodiments of the invention have been described and illustrated, such embodiments should be considered illustrative of the invention only and not as limiting the invention as construed in accordance with the accompanying claims.

What is claimed is:

1. A method of coupling a boot body to a fin apparatus comprising a fin body coupled to a foot coupling portion, the method comprising:
 - 5 connecting a first boot connector on the foot coupling portion to a first complementary boot connector on a top side of the boot body; and
 - connecting a second boot connector on the foot coupling portion to a second complementary boot connector on a bottom side of the boot body;
 - 10 wherein connecting the second boot connector to the second complementary boot connector comprises positioning a holding surface of the second boot connector against a retaining surface on the bottom side of the boot body; and
 - 15 wherein the retaining surface on the bottom side of the boot body is positioned to retain the second boot connector against movement in a direction towards the fin body when the holding surface of the second boot connector is positioned against the retaining surface on the bottom side of the boot body.
2. The method of claim 1 wherein the foot coupling portion comprises a unitary body having the first and second boot connectors.
- 20 3. The method of claim 1 or 2 wherein connecting the first boot connector to the first complementary boot connector comprises positioning a holding surface of the first boot connector against a retaining surface on the top side of the boot body.
- 25 4. The method of claim 3 wherein the retaining surface on the top side of the boot body is positioned to retain the first boot connector against movement in the direction towards the fin body when the holding surface of the first boot

connector is positioned against the retaining surface on the top side of the boot body.

5. The method of claim **3** or **4** wherein positioning the holding surface of the first boot connector against the retaining surface on the top side of the boot body comprises receiving a projection on a top portion of the foot coupling portion in a receptacle on the top side of the boot body.
5
6. The method of claim **5** wherein the projection on the top portion of the foot coupling portion projects inward from the top portion of the foot coupling portion, and wherein the holding surface of the first boot connector is on the projection on the top portion of the foot coupling portion on an inward side of the top portion of the foot coupling portion.
10
7. The method of claim **5** or **6** wherein receiving the projection on the top portion of the foot coupling portion in the receptacle on the top side of the boot body comprises receiving the projection on the top portion of the foot coupling portion in the receptacle on the top side of the boot body from the top side of the boot body.
15
8. The method of any one of claims **1** to **7** wherein at least one of connecting the first boot connector to the first complementary boot connector and connecting the second boot connector to the second complementary boot connector comprises resiliently deforming the foot coupling portion to increase a separation distance between the first and second boot connectors.
20
9. The method of any one of claims **1** to **8** wherein the boot body comprises a boot shell.
10. The method of any one of claims **1** to **8** wherein the boot body is an integrally formed boot.
25

11. The method of any one of claims **1** to **10** wherein the boot body is shaped to receive at least a portion of a foot.
12. The method of any one of claims **1** to **11** wherein the foot coupling portion comprises first and second ends, wherein the first boot connector is on the first end of the foot coupling portion, and wherein the second boot connector is on the second end of the foot coupling portion.
13. The method of any one of claims **1** to **12** wherein positioning the holding surface of the second boot connector against the retaining surface on the bottom side of the boot body comprises receiving a projection on a bottom portion of the foot coupling portion in a receptacle on the bottom side of the boot body.
14. The method of claim **13** wherein the projection on the bottom portion of the foot coupling portion projects inward from the bottom portion of the foot coupling portion, and wherein the holding surface of the second boot connector is on the projection on the bottom portion of the foot coupling portion on an inward side of the bottom portion of the foot coupling portion.
15. The method of claim **13** or **14** wherein receiving the projection on the bottom portion of the foot coupling portion in the receptacle on the bottom side of the boot body comprises receiving the projection on the bottom portion of the foot coupling portion in the receptacle on the bottom side of the boot body from the bottom side of the boot body.
16. The method of any one of claims **1** to **15** wherein the first complementary boot connector is in a first region of a foot holding portion of the boot body on a front end of the foot holding portion of the boot body, and wherein the second complementary boot connector is in a second region of the foot holding portion of the boot body on the front end of the foot holding portion of the boot body.

17. A fin apparatus coupleable to a boot body, the fin apparatus comprising:

a fin body; and

a foot coupling portion coupled to the fin body and comprising:

5

a first boot connector connectable with a first complementary boot connector on a top side of the boot body; and

a second boot connector connectable with a second complementary boot connector on a bottom side of the boot body;

10

wherein the second boot connector comprises a holding surface positionable against a retaining surface on the bottom side of the boot body; and

15

wherein the second boot connector is configured to be retained against movement in a direction towards the fin body when the holding surface of the second boot connector is positioned against the retaining surface on the bottom side of the boot body.

18. The apparatus of claim **17** wherein the foot coupling portion comprises a unitary body having the first and second boot connectors.

20

19. The apparatus of claim **17** or **18** wherein the foot coupling portion comprises first and second ends, wherein the first boot connector is on the first end of the foot coupling portion, and wherein the second boot connector is on the second end of the foot coupling portion.

20. The apparatus of claim **17**, **18**, or **19** wherein the first boot connector comprises a holding surface positionable against a retaining surface on the top side of the boot body.

21. The apparatus of claim **20** wherein the first boot connector is configured to be retained against movement in the direction towards the fin body when the holding surface of the first boot connector is positioned against the retaining surface on the top side of the boot body.
- 5 22. The apparatus of claim **21** wherein the first boot connector comprises a projection on a top portion of the foot coupling portion, the projection on the top portion of the foot coupling portion comprising the holding surface of the first boot connector and receivable in a receptacle on the top side of the boot body.
- 10 23. The apparatus of claim **22** wherein the projection on the top portion of the foot coupling portion projects inward from the top portion of the foot coupling portion, and wherein the holding surface of the first boot connector is on the projection on the top portion of the foot coupling portion on an inward side of the top portion of the foot coupling portion.
- 15 24. The apparatus of any one of claims **17** to **23** wherein the foot coupling portion is resiliently deformable to increase a separation distance between the first and second boot connectors.
- 20 25. The apparatus of any one of claims **17** to **24** wherein the second boot connector comprises a projection on a bottom portion of the foot coupling portion, the projection on the bottom portion of the foot coupling portion comprising the holding surface of the second boot connector and receivable in a receptacle on the bottom side of the boot body.
- 25 26. The apparatus of claim **25** wherein the projection on the bottom portion of the foot coupling portion projects inward from the bottom portion of the foot coupling portion, and wherein the holding surface of the second boot connector is on the projection on the bottom portion of the foot coupling portion on an inward side of the bottom portion of the foot coupling portion.

27. A system comprising:

the apparatus of any one of claims **17** to **26**; and

the boot body;

wherein the boot body comprises:

5 the first complementary boot connector on the top side of the
boot body; and

the second complementary boot connector on the bottom side of
the boot body;

10 wherein the second complementary boot connector comprises the
retaining surface on the bottom side of the boot body; and

15 wherein the retaining surface on the bottom side of the boot body is
positioned to retain the second boot connector against movement in the
direction towards the fin body when the holding surface of the second
boot connector is positioned against the retaining surface on the bottom
side of the boot body.

28. The system of claim **27**, when directly or indirectly dependent from claim **20**,
wherein the first complementary boot connector comprises the retaining
surface on the top side of the boot body.

20 **29.** The system of claim **28** wherein the retaining surface on the top side of the
boot body is positioned to retain the first boot connector against movement in
the direction towards the fin body when the holding surface of the first boot
connector is positioned against the retaining surface on the top side of the boot
body.

30. The system of claim **28** or **29**, when directly or indirectly dependent from claim **22**, wherein the first complementary boot connector comprises the receptacle comprising the retaining surface on the top side of the boot body.
- 5 31. The system of claim **30** wherein the receptacle comprising the retaining surface on the top side of the boot body is open to the top side of the boot body and configured to receive the first boot connector from the top side of the boot body.
- 10 32. The system of any one of claims **27** to **31**, when directly or indirectly dependent from claim **25**, wherein the second complementary boot connector comprises the receptacle comprising the retaining surface on the bottom side of the boot body.
- 15 33. The system of claim **32** wherein the receptacle comprising the retaining surface on the bottom side of the boot body is open to the bottom side of the boot body and configured to receive the second boot connector from the bottom side of the boot body.
34. The system of any one of claims **27** to **33** wherein the boot body comprises a boot shell.
35. The system of any one of claims **27** to **33** wherein the boot body is an integrally formed boot.
- 20 36. The system of any one of claims **27** to **35** wherein the boot body is shaped to receive at least a portion of a foot.
- 25 37. The system of any one of claims **27** to **36** wherein the boot body comprises a foot holding portion, wherein the first complementary boot connector is in a first region of the foot holding portion of the boot body on a front end of the foot holding portion of the boot body, and wherein the second complementary boot

connector is in a second region of the foot holding portion of the boot body on the front end of the foot holding portion of the boot body.

38. A boot body coupleable to a fin apparatus comprising a fin body and a foot coupling portion, the boot body comprising:

5 a first boot connector on a top side of the boot body connectable with a first complementary boot connector on the foot coupling portion; and

a second boot connector on a bottom side of the boot body connectable with a second complementary boot connector on the foot coupling portion;

10 wherein the second boot connector comprises a retaining surface on the bottom side of the boot body for contacting a holding surface on the second complementary boot connector; and

15 wherein the retaining surface on the bottom side of the boot body is positioned to retain the second complementary boot connector against movement in a direction towards the fin body when the holding surface of the second complementary boot connector is positioned against the retaining surface on the bottom side of the boot body.

39. The boot body of claim **38** wherein the first boot connector comprises a retaining surface on the top side of the boot body for contacting a holding surface on the first complementary boot connector.

40. The boot body of claim **39** wherein the retaining surface on the top side of the boot body is positioned to retain the first complementary boot connector against movement in the direction towards the fin body when the holding surface of the first complementary boot connector is positioned against the retaining surface on the top side of the boot body.

41. The boot body of claim **39** or **40** wherein the first boot connector comprises a receptacle comprising the retaining surface on the top side of the boot body.
42. The boot body of claim **41** wherein the receptacle comprising the retaining surface on the top side of the boot body is open to the top side of the boot body and configured to receive the first complementary boot connector from the top side of the boot body.
- 5
43. The boot body of any one of claims **38** to **42** wherein the boot body comprises a boot shell.
44. The boot body of any one of claims **38** to **42** wherein the boot body is an integrally formed boot.
- 10
45. The boot body of any one of claims **38** to **44** wherein the boot body is shaped to receive at least a portion of a foot.
46. The boot body of any one of claims **38** to **45** wherein the second boot connector comprises a receptacle comprising the retaining surface on the bottom side of the boot body.
- 15
47. The boot body of claim **46** wherein the receptacle comprising the retaining surface on the bottom side of the boot body is open to the bottom side of the boot body and configured to receive the second complementary boot connector from the bottom side of the boot body.
- 20
48. The boot body of any one of claims **38** to **47** further comprising a foot holding portion, wherein the first boot connector is in a first region of the foot holding portion on a front end of the foot holding portion, and wherein the second boot connector is in a second region of the foot holding portion on the front end of the foot holding portion.

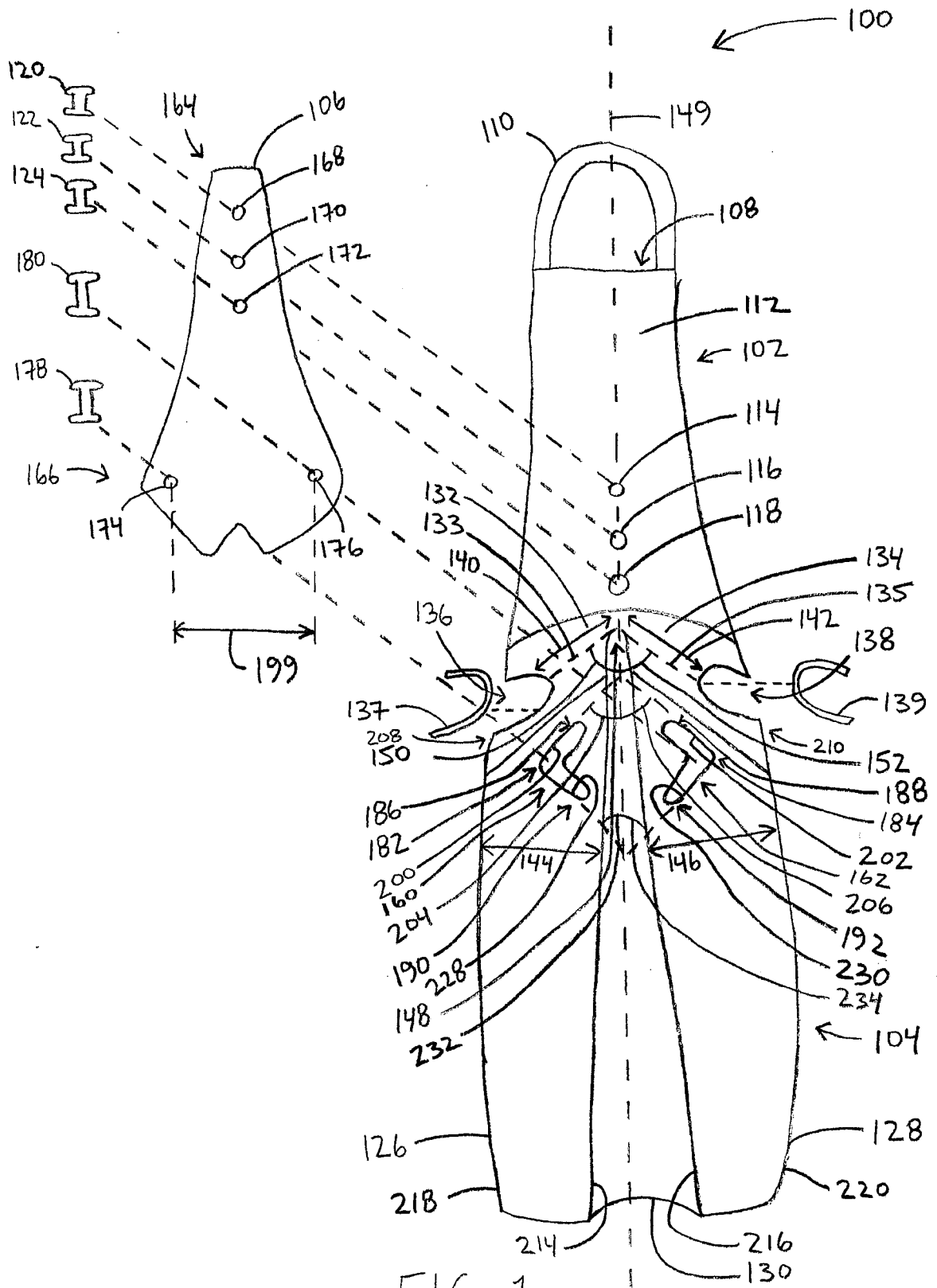
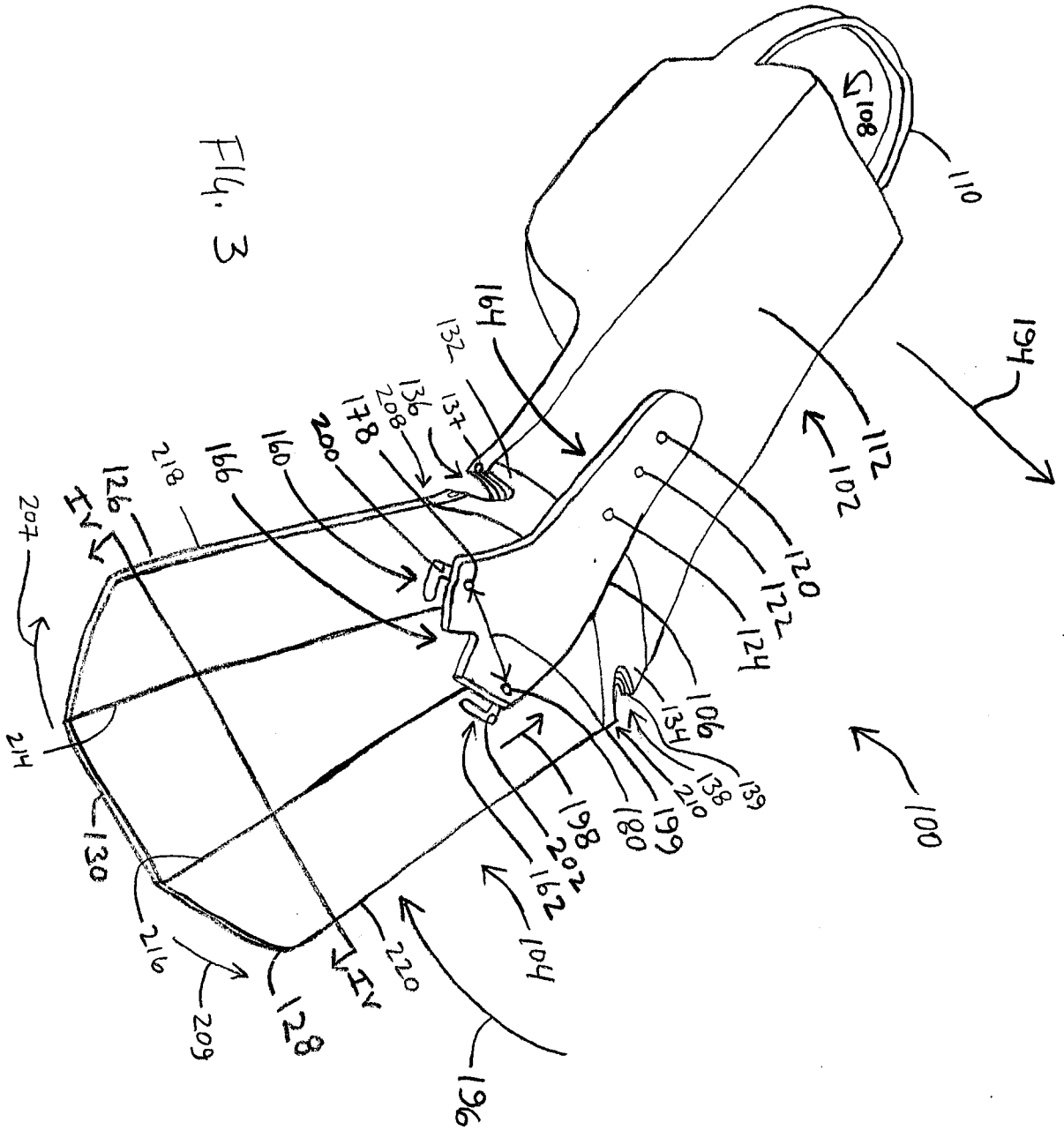

FIG. 1

FIG. 3



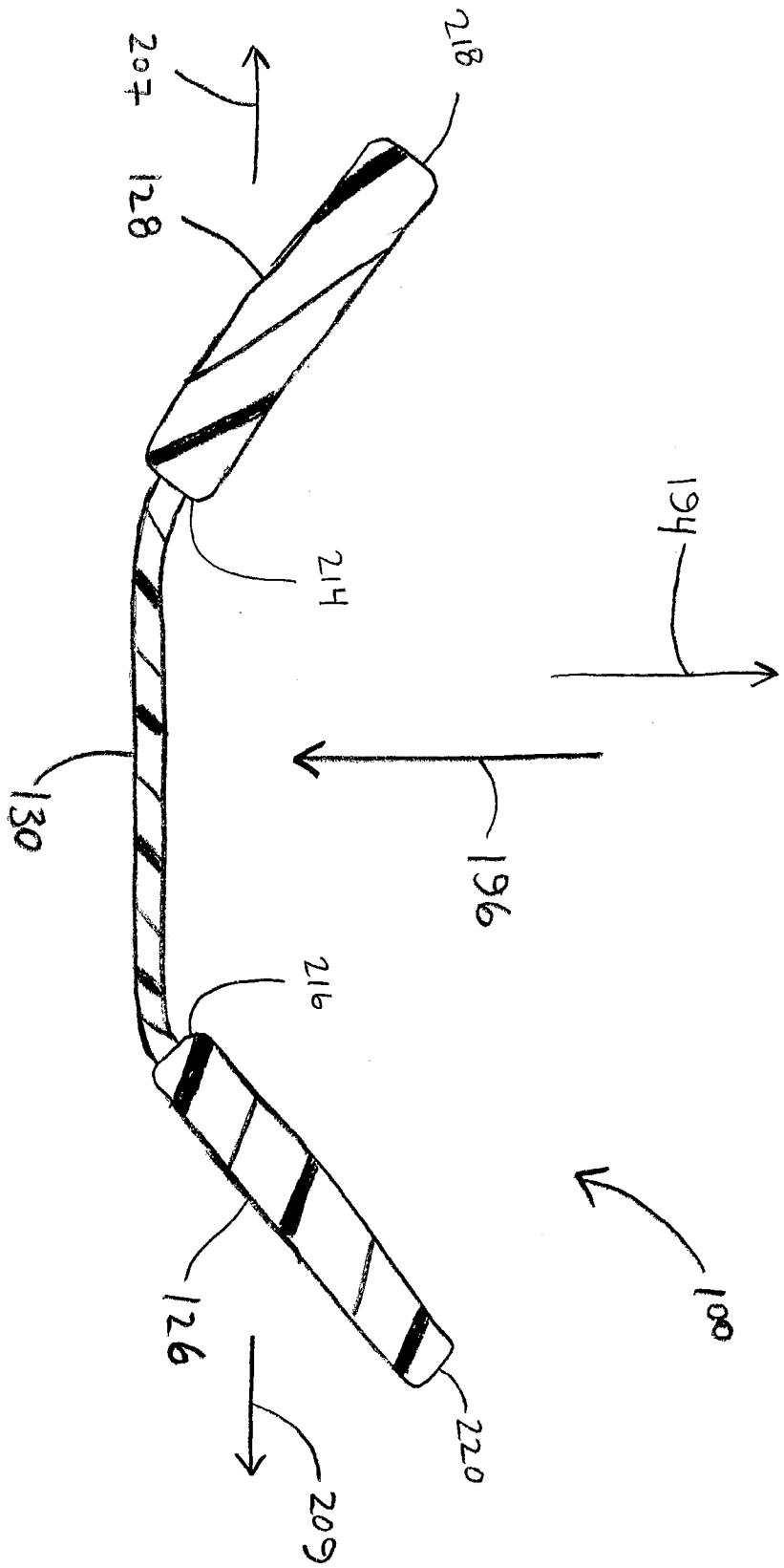

FIG. 4

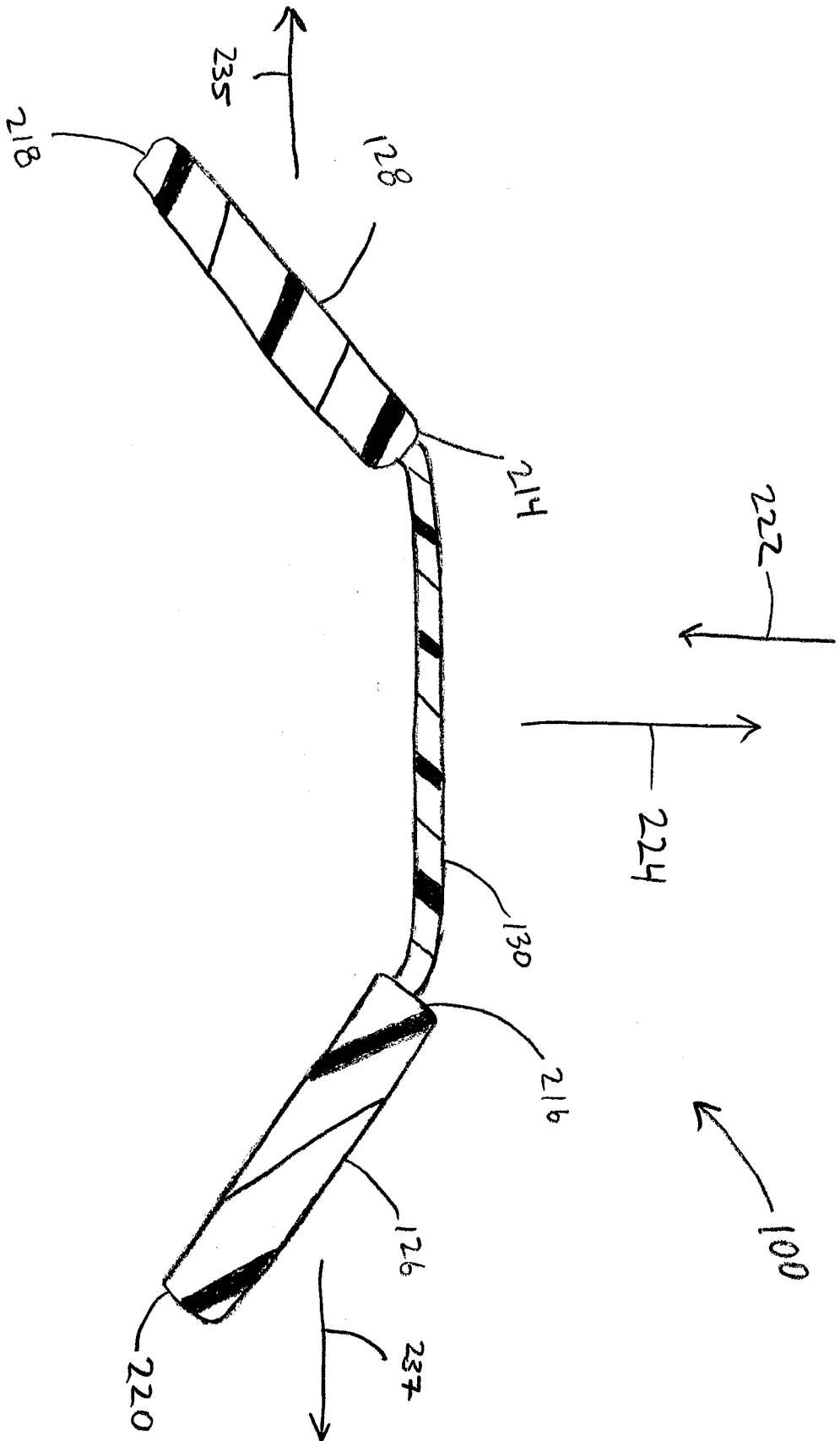

FIG. 6

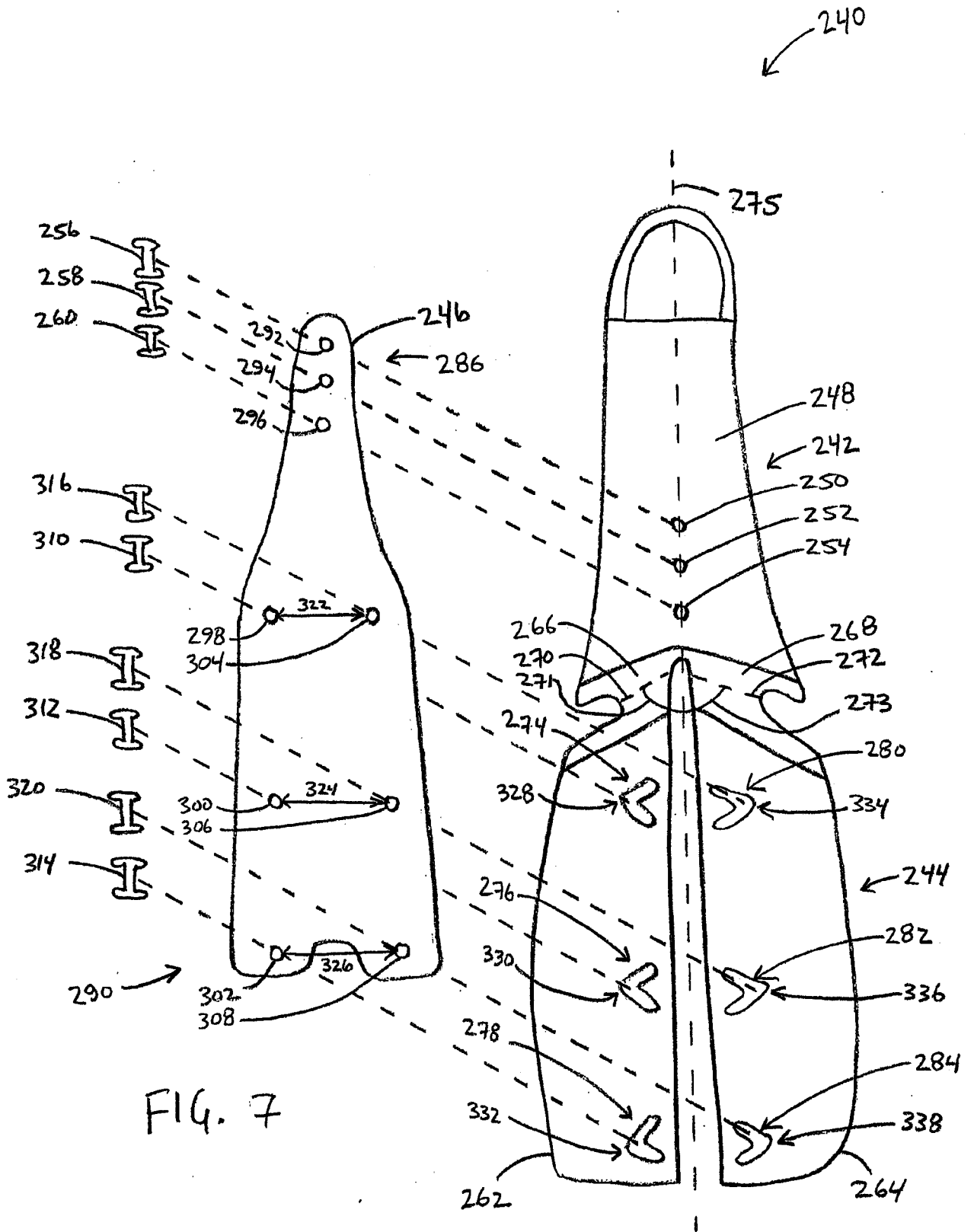

FIG. 7

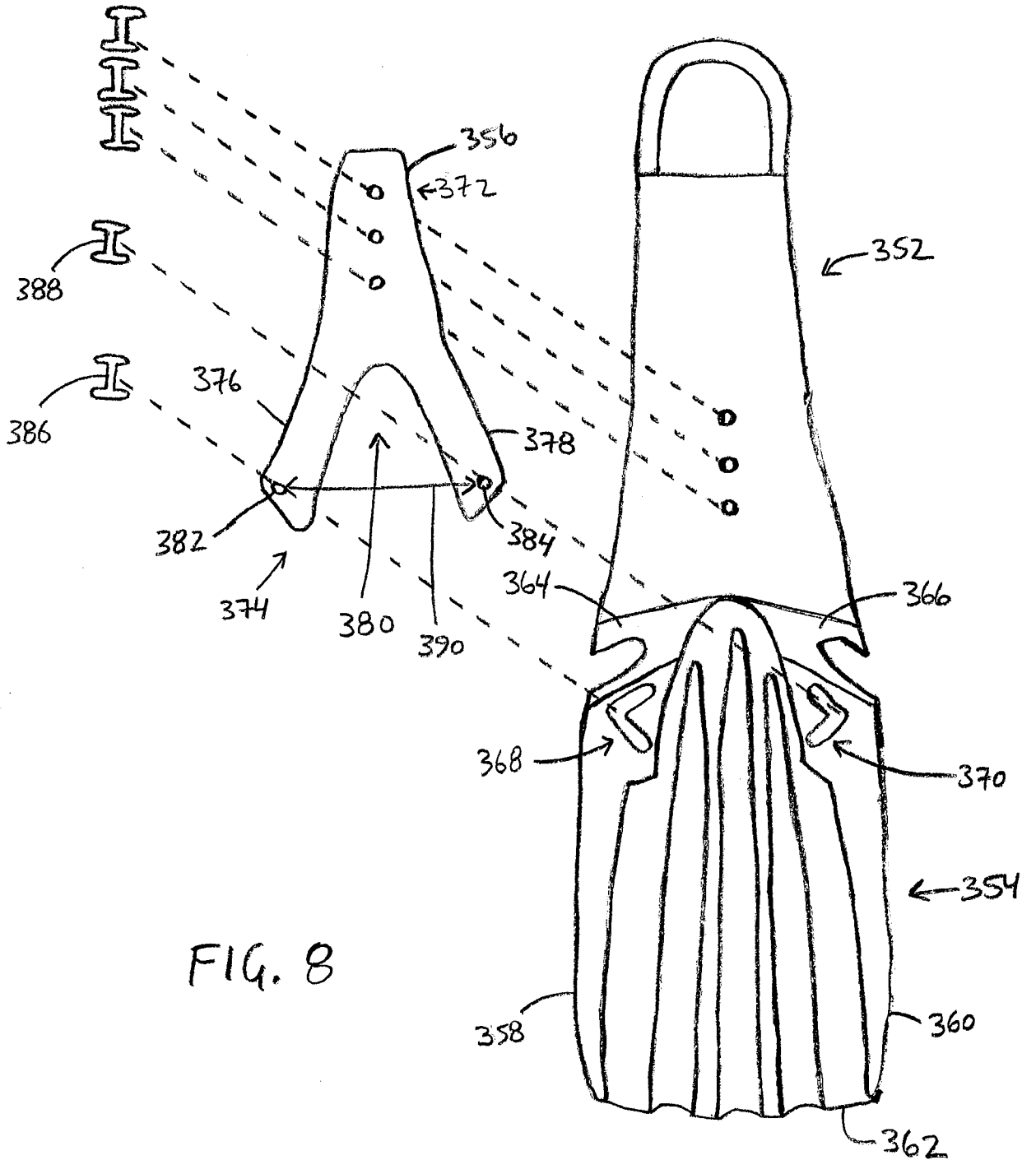

FIG. 8

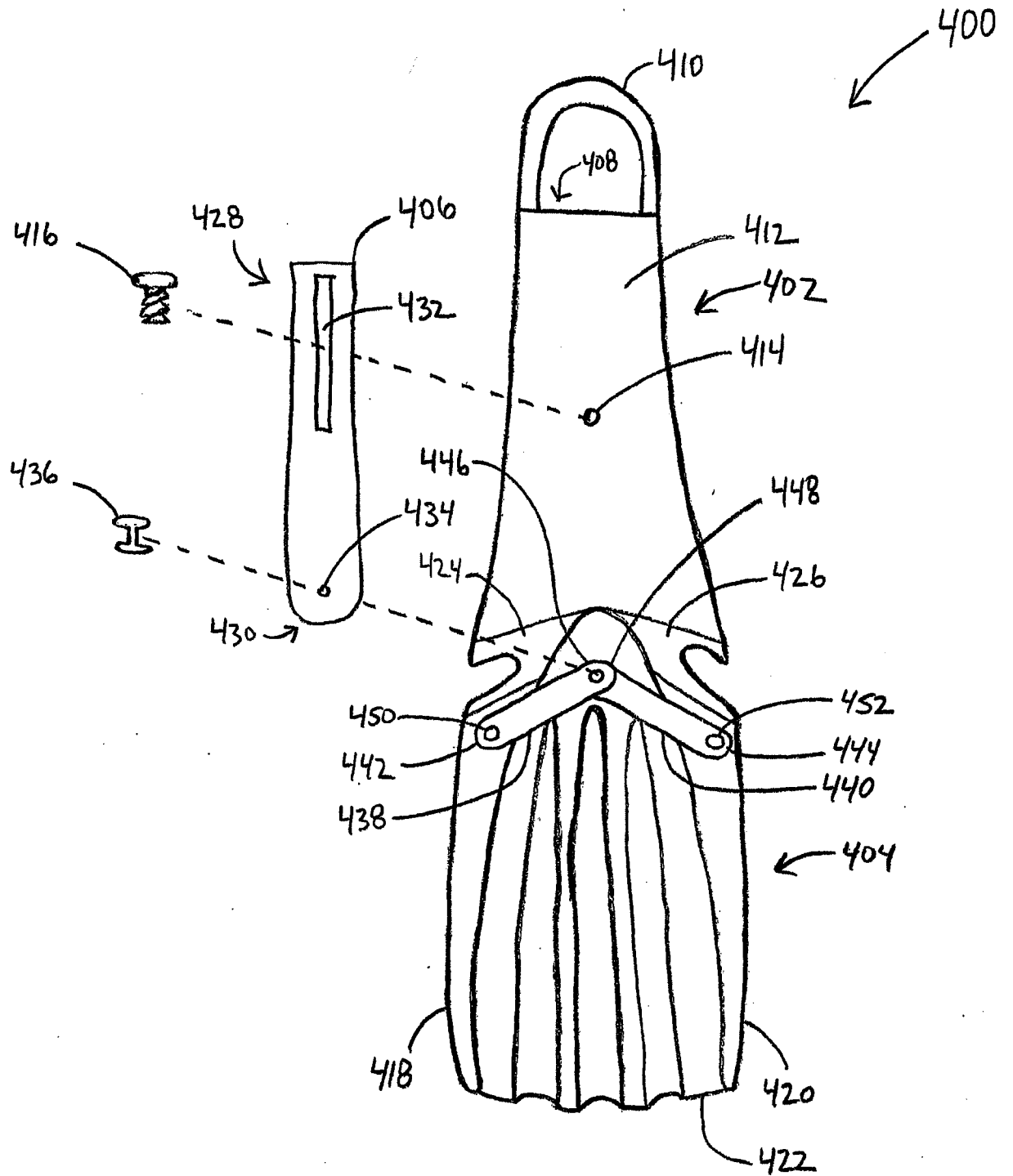

FIG. 9

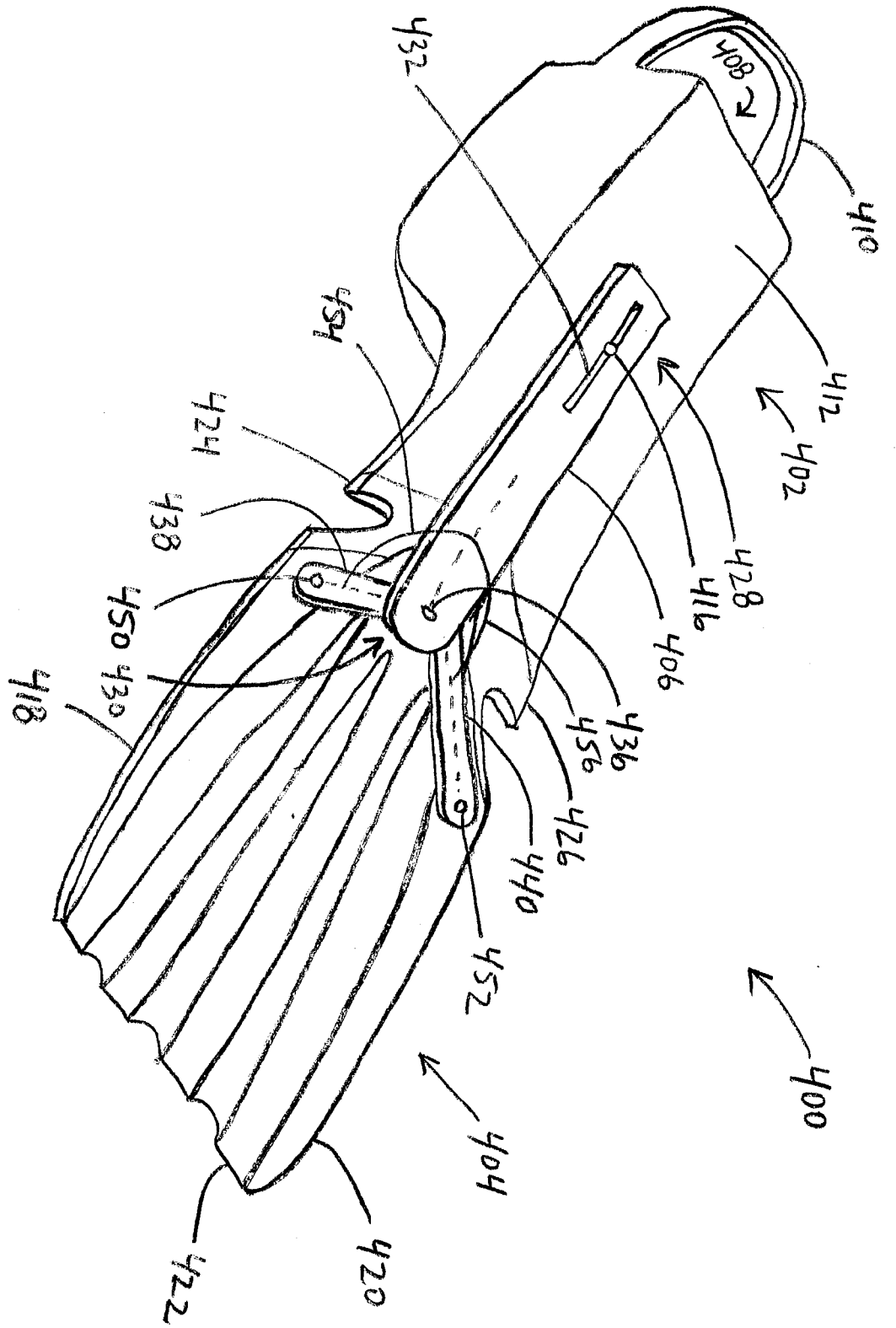

FIG. 10

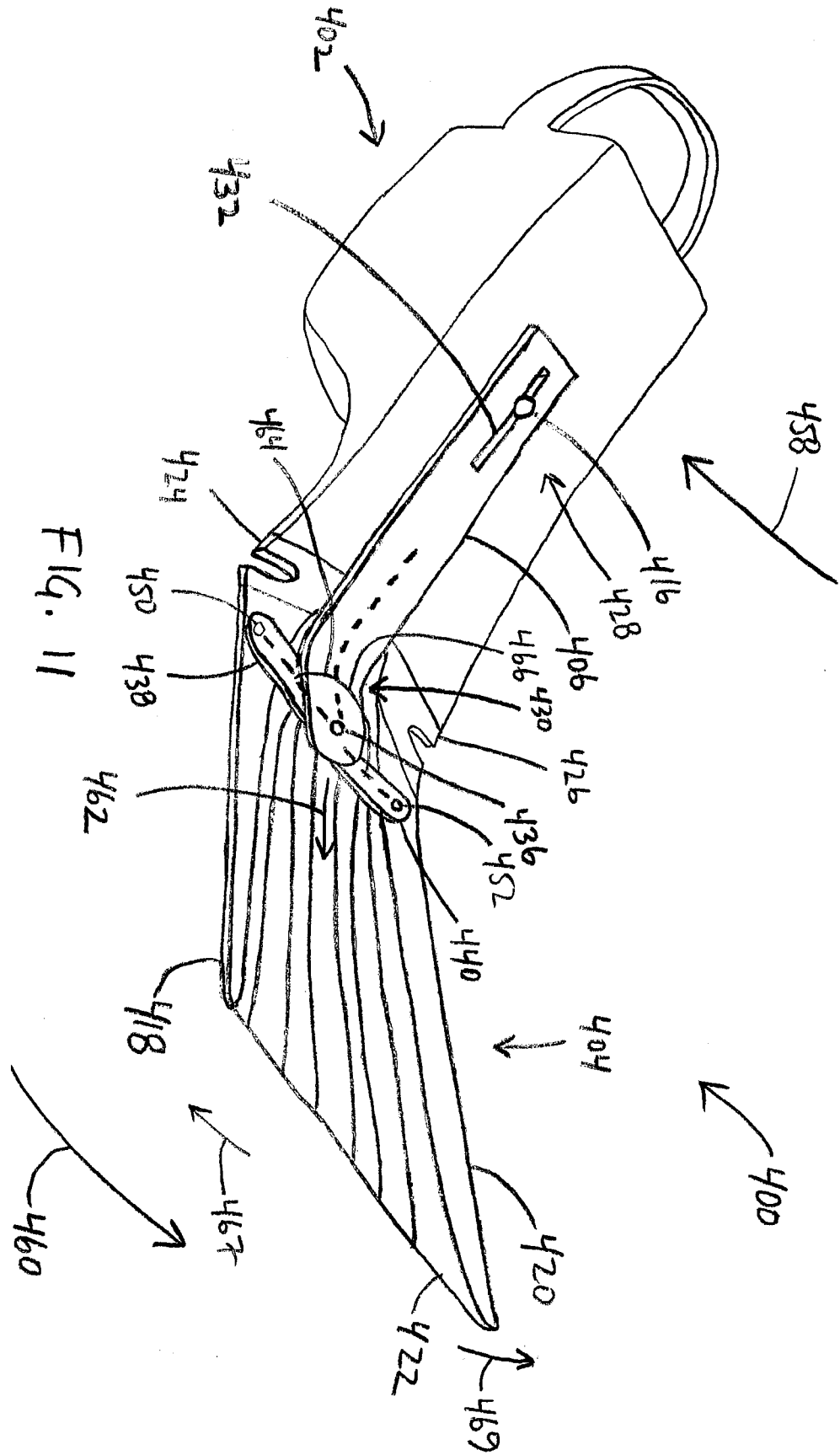
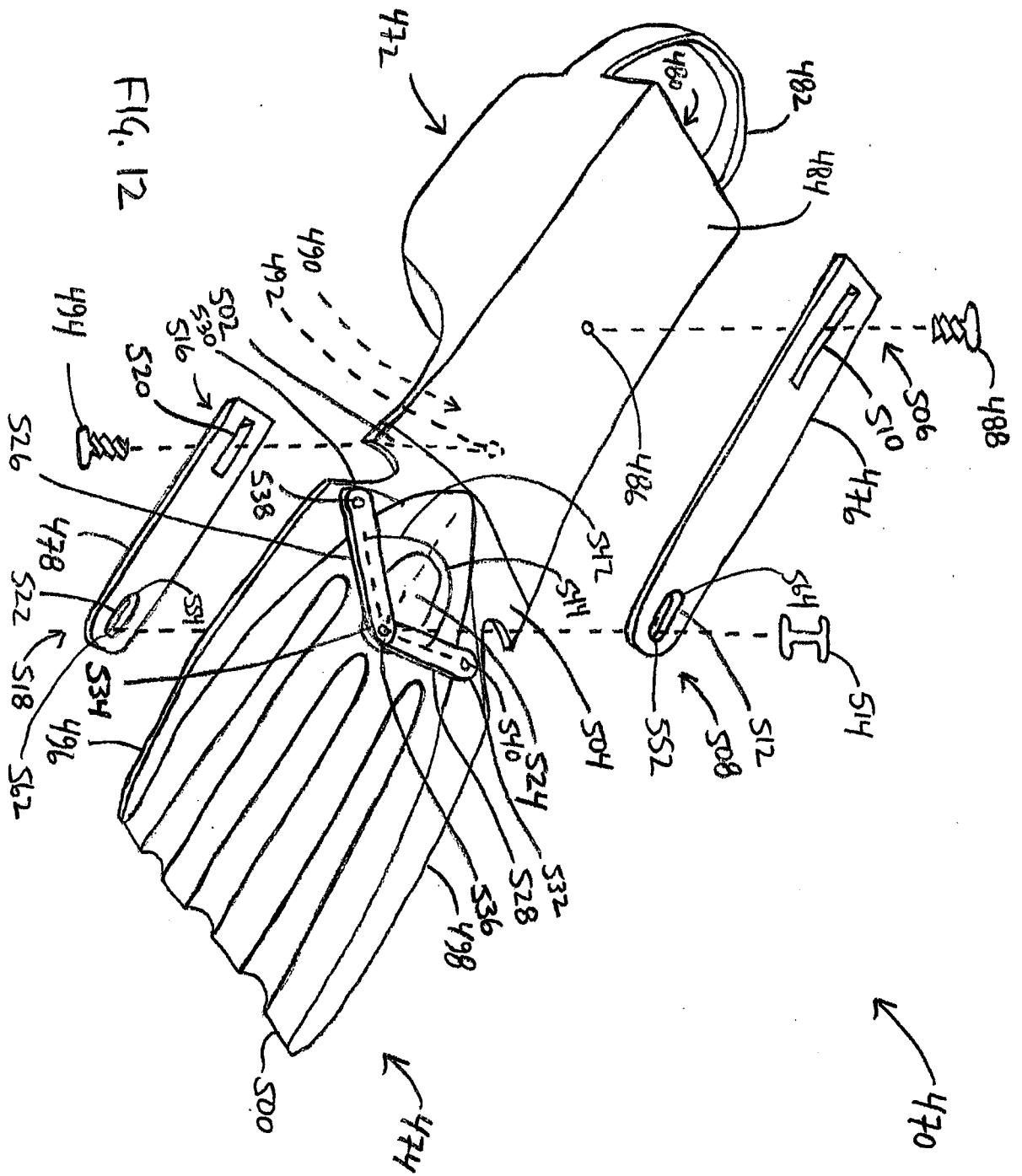

FIG. 11



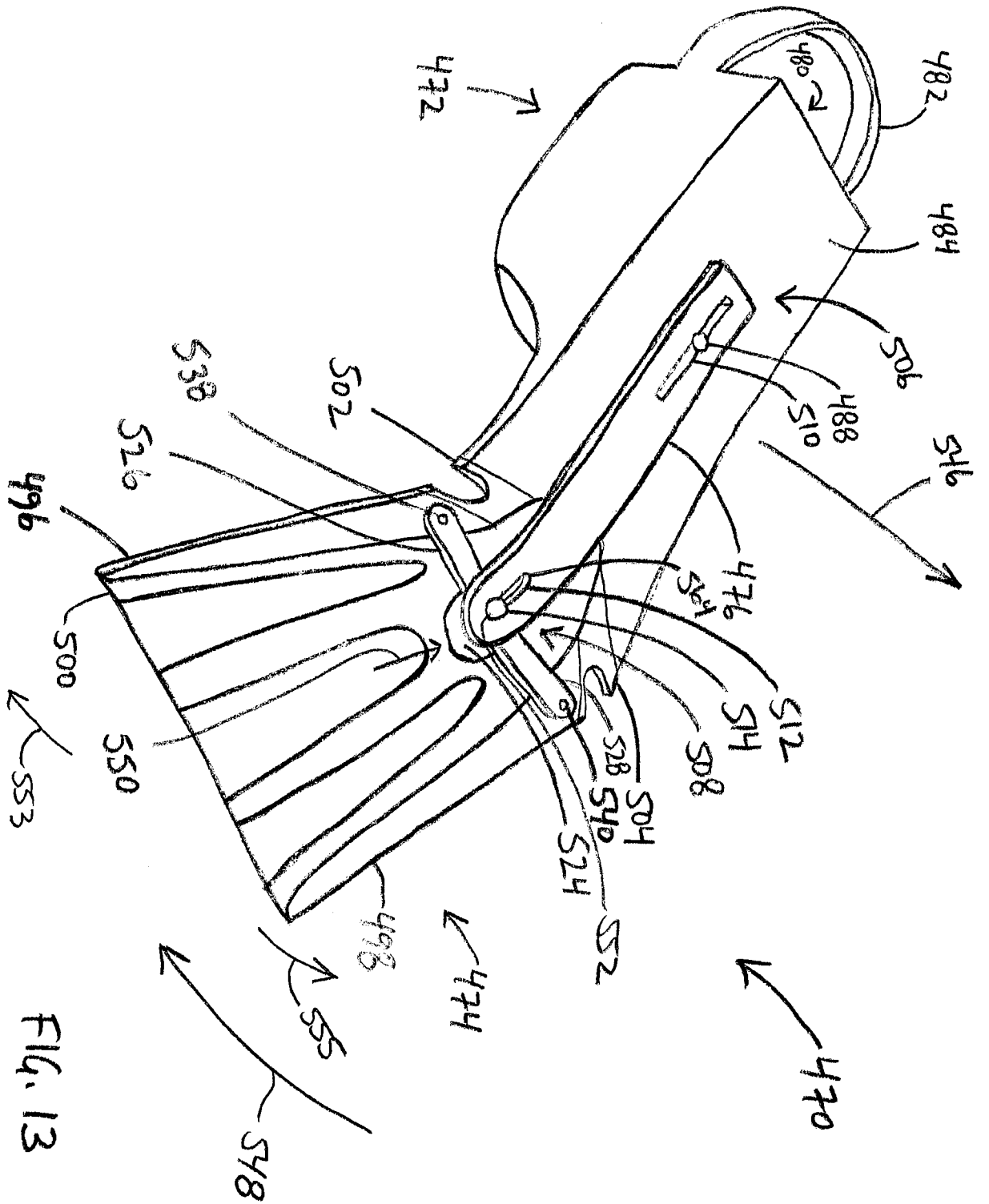

FIG. 13

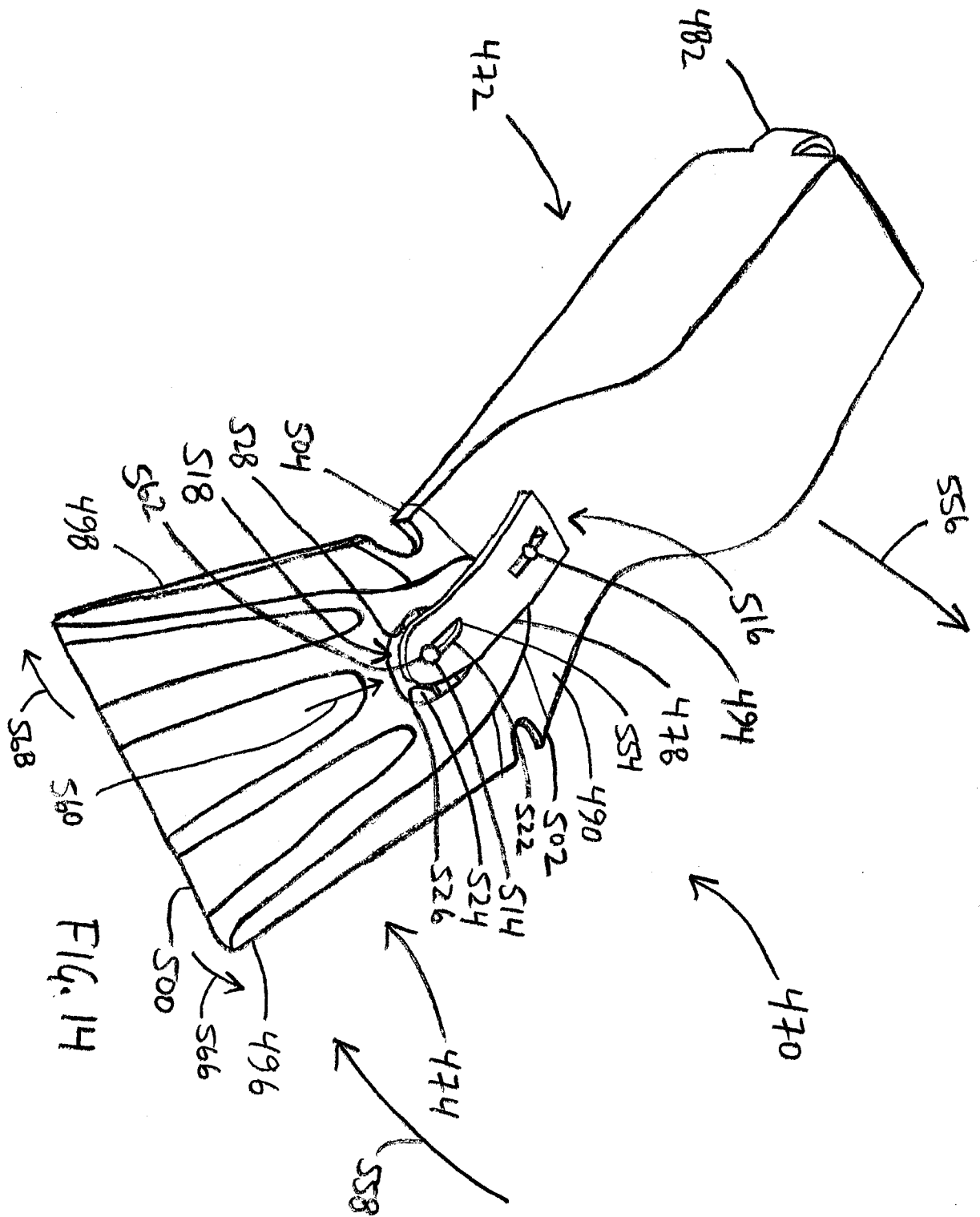

FIG. 14

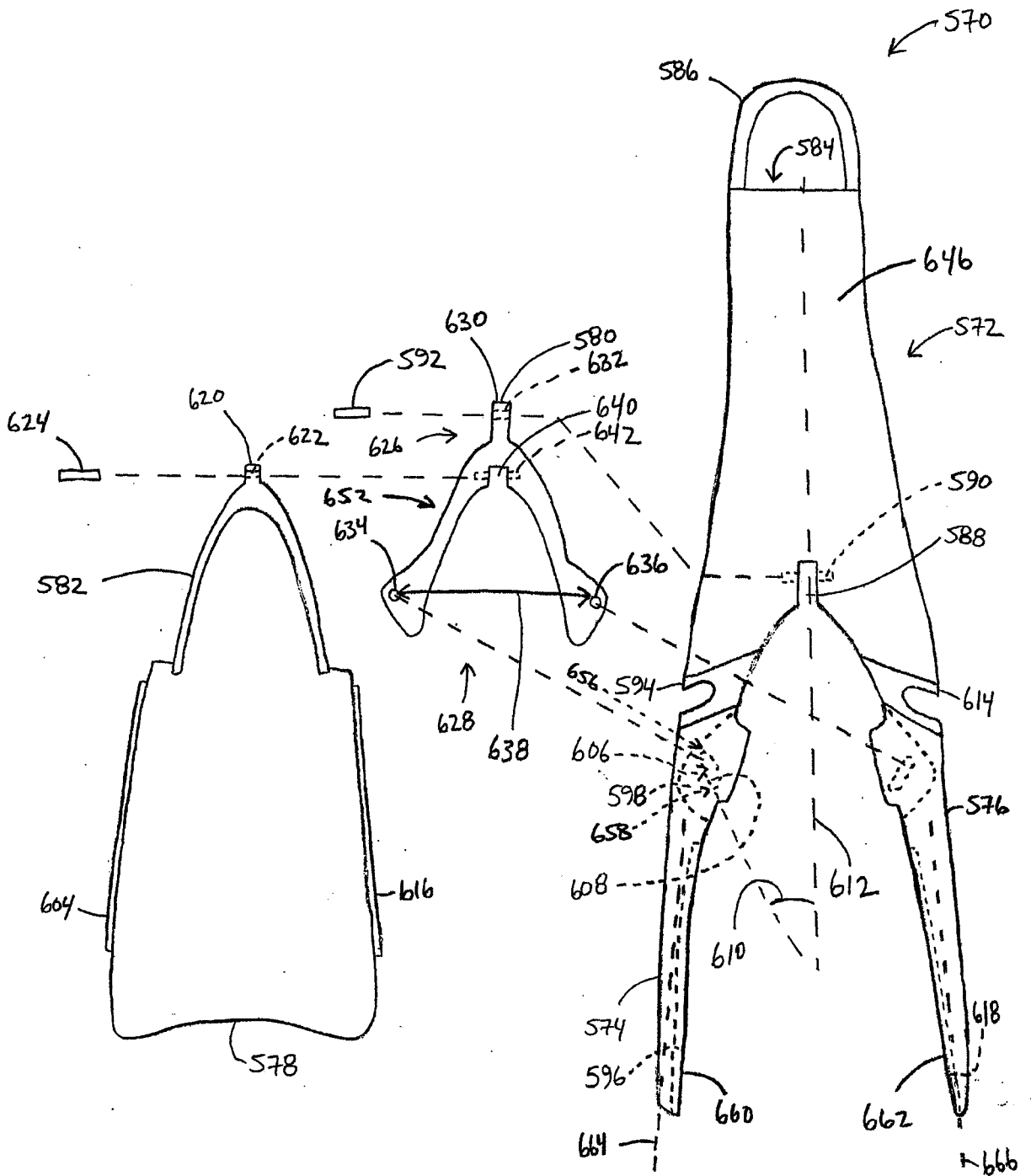

FIG. 15

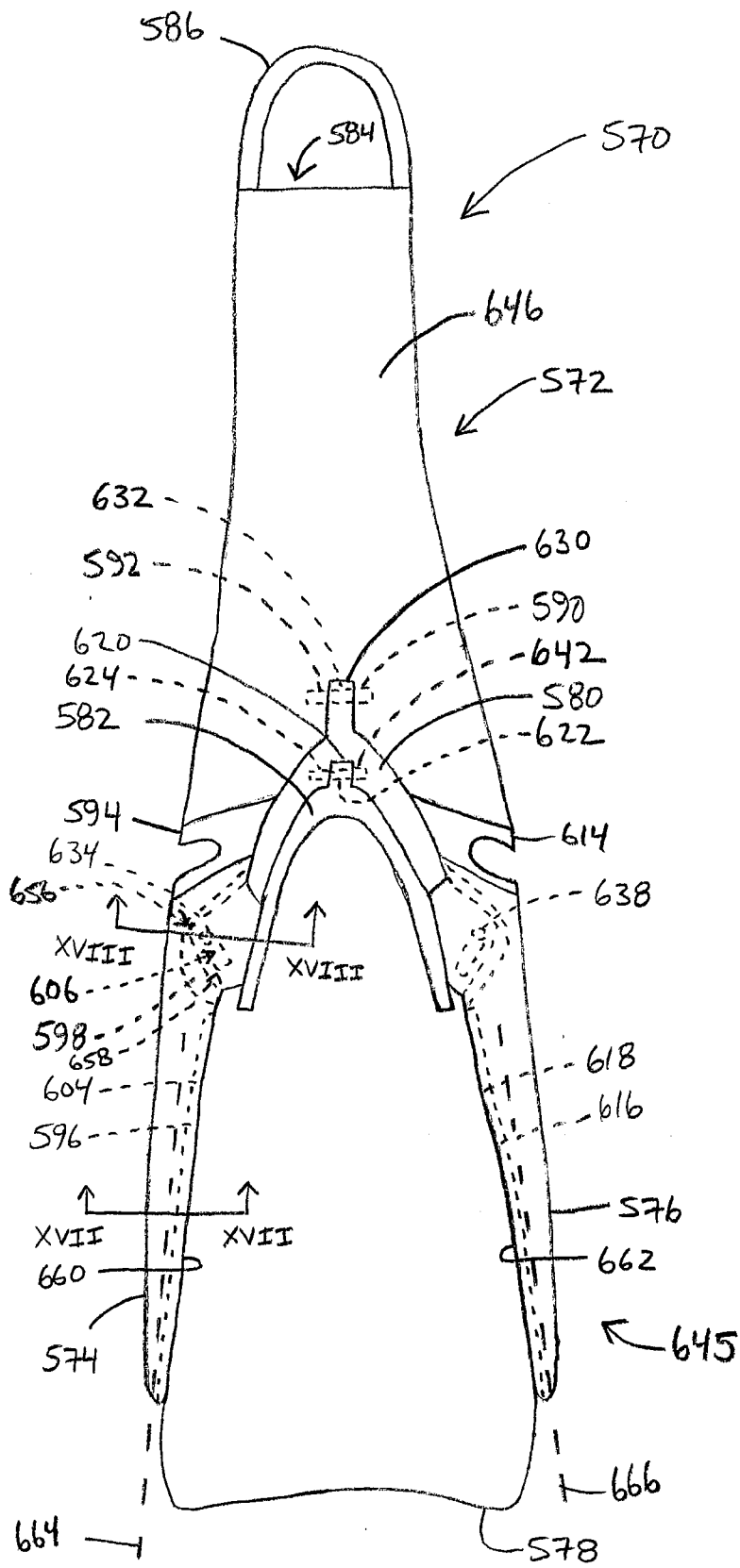

FIG. 16

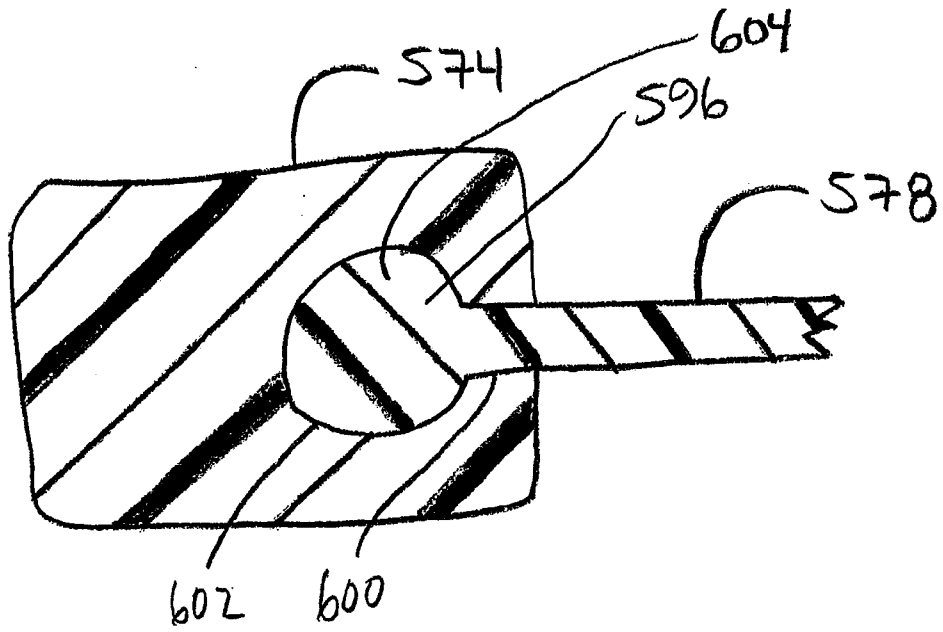

FIG. 17

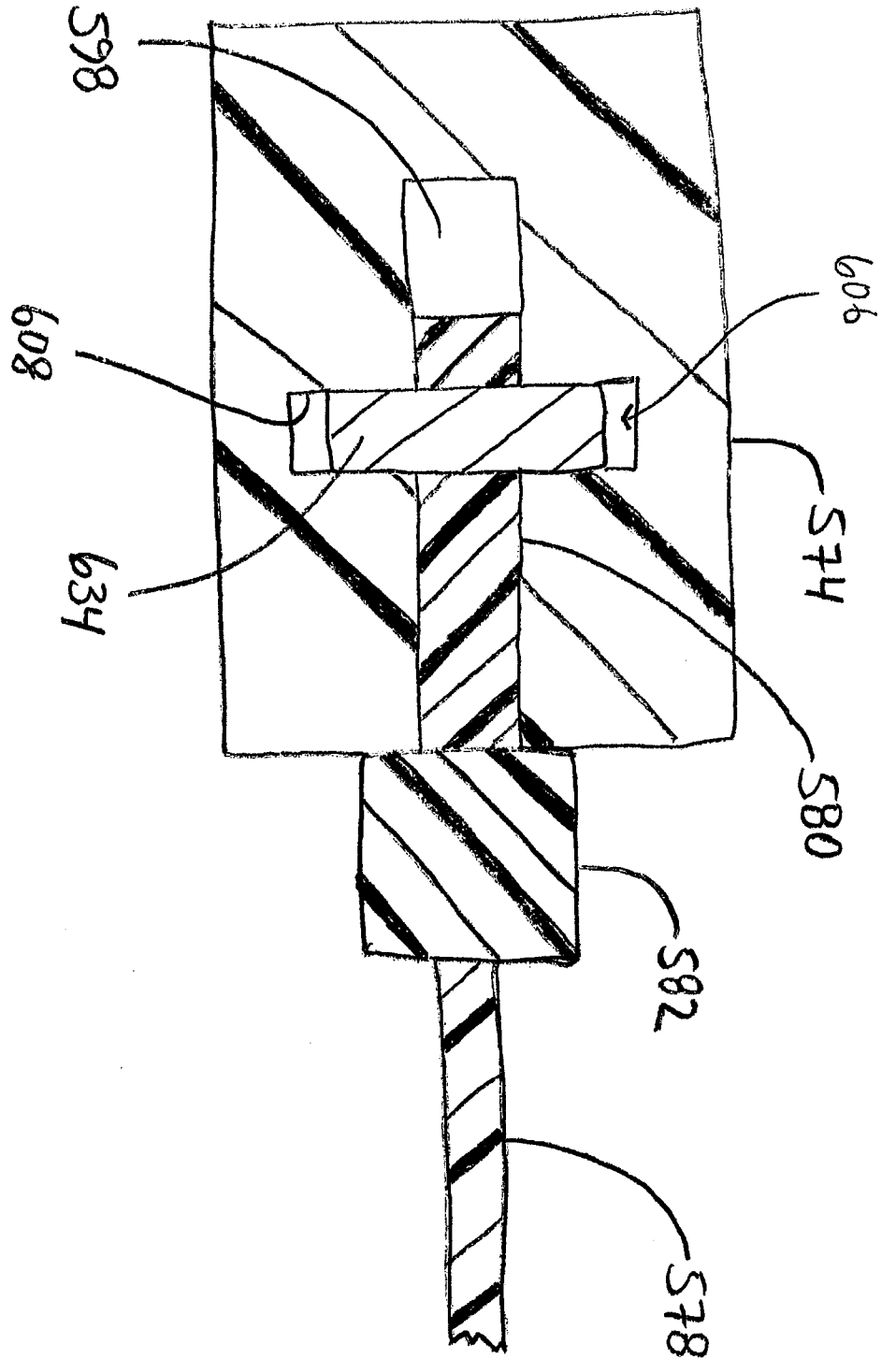

FIG. 18

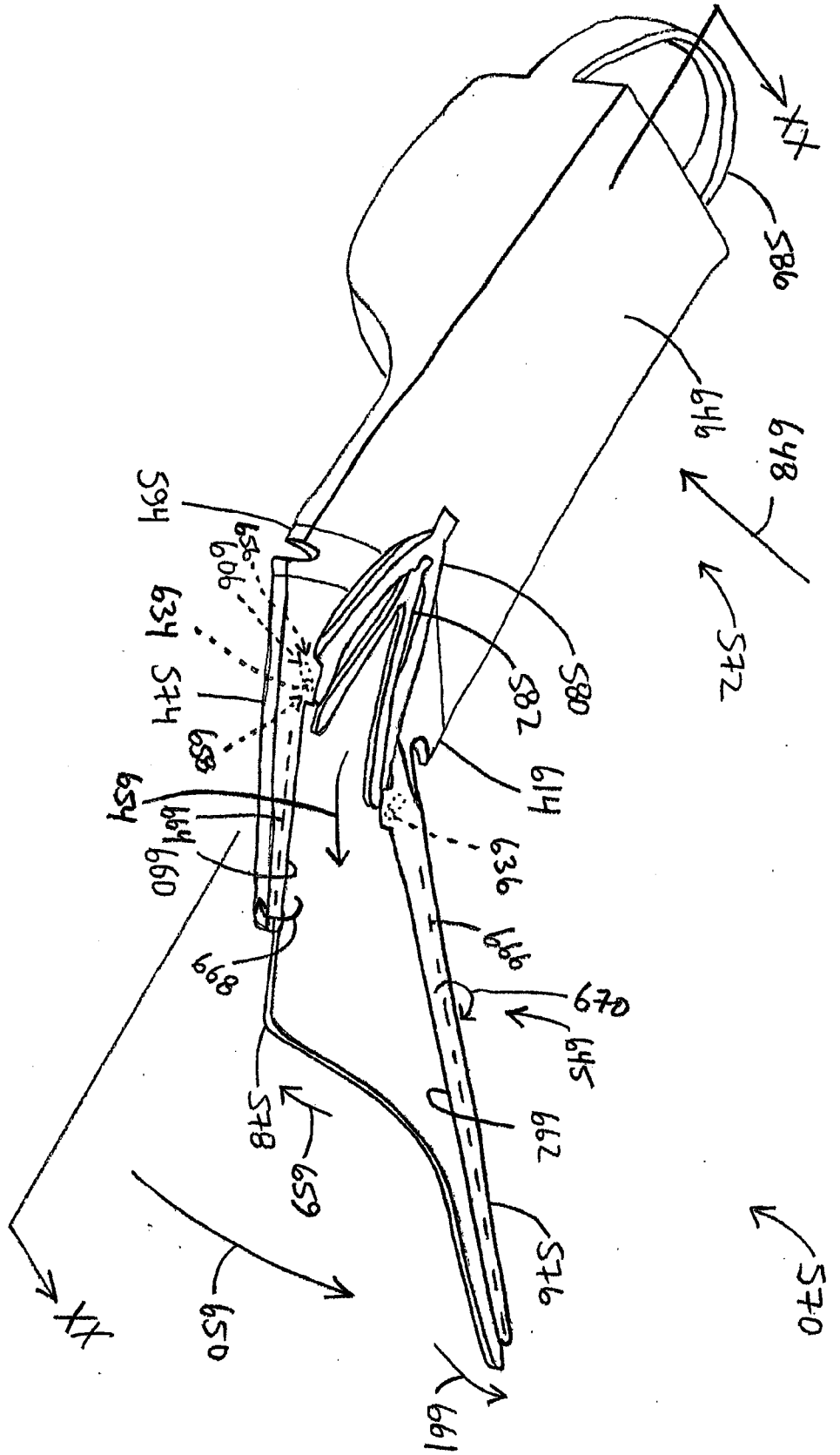

FIG. 19

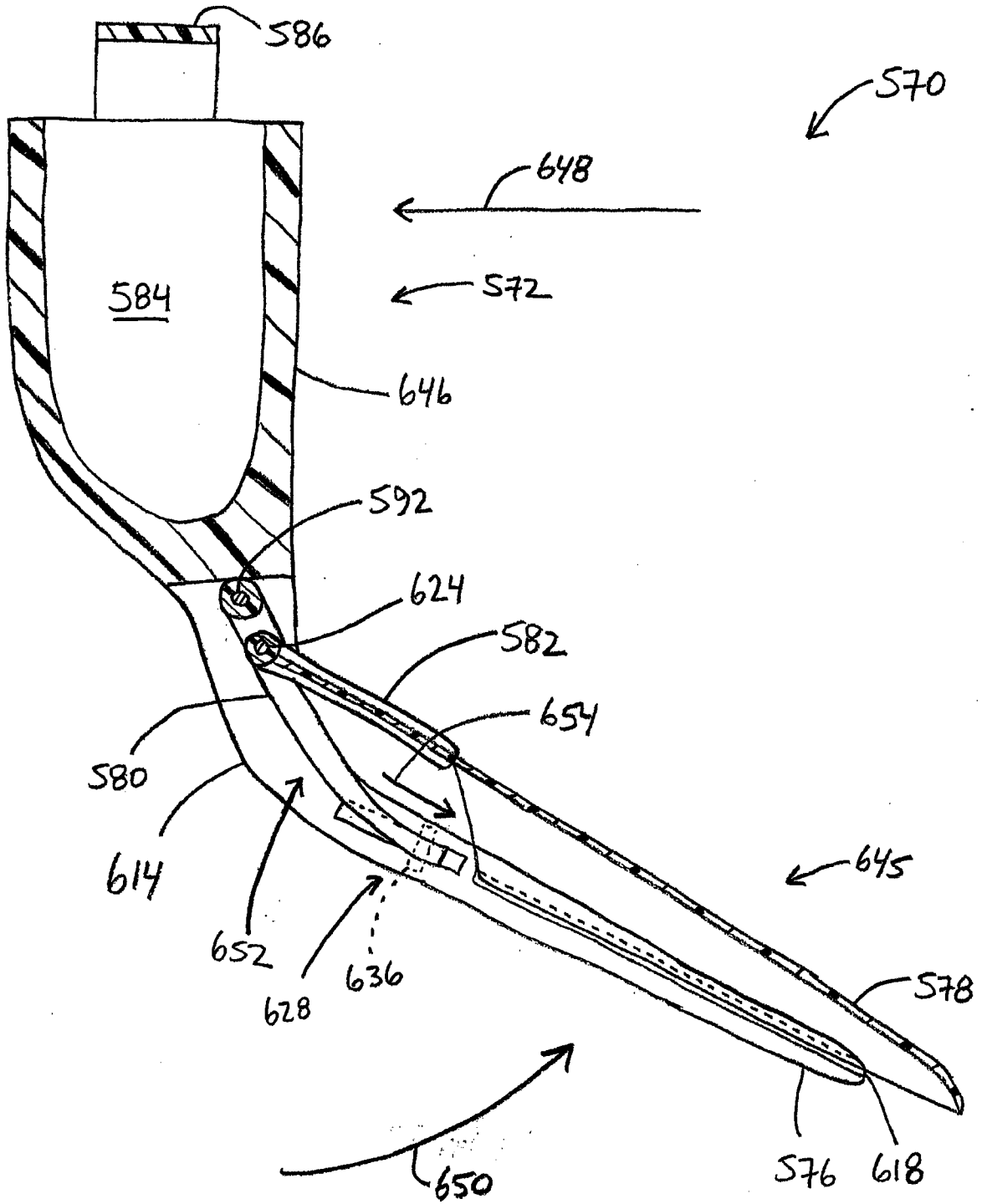
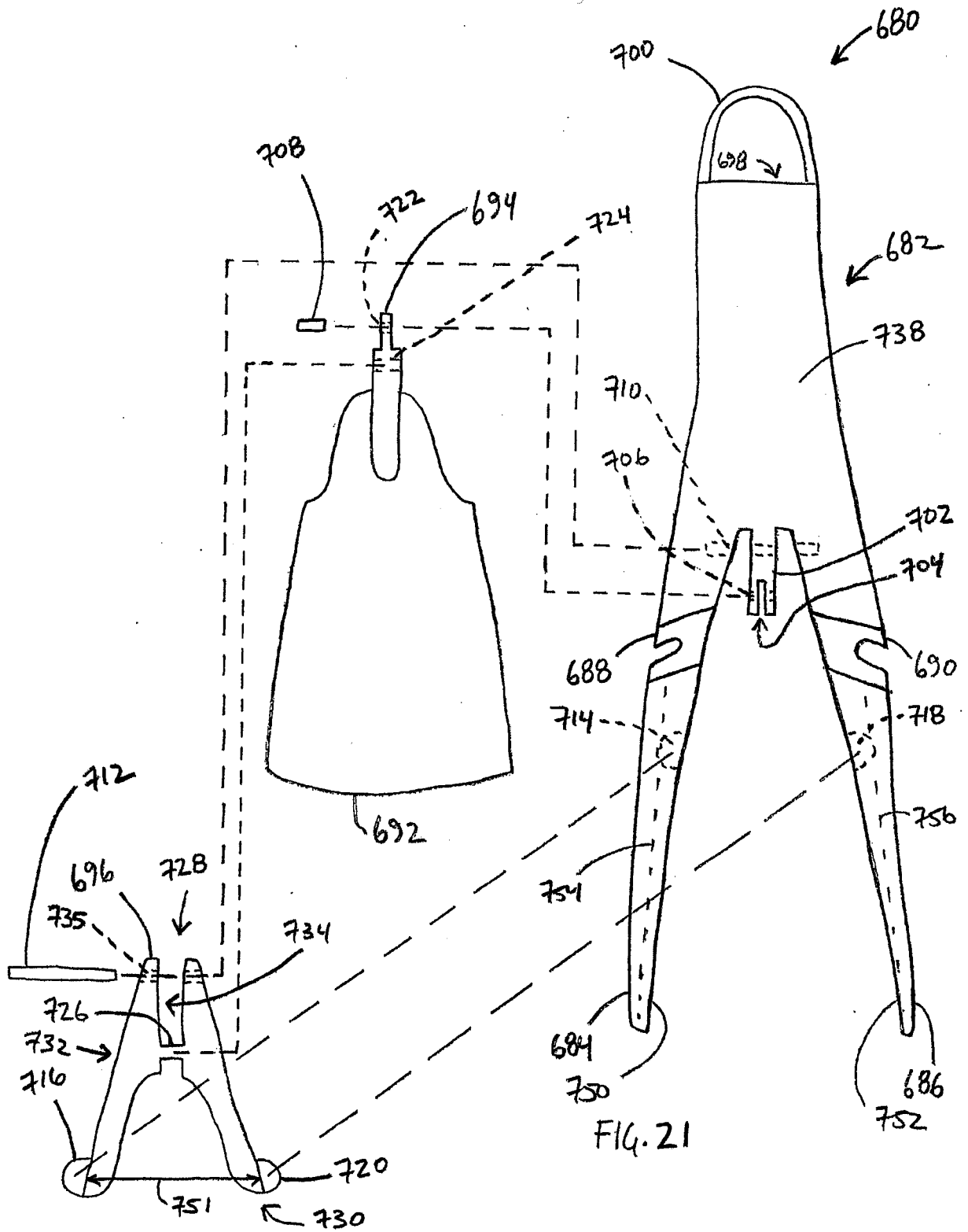

FIG. 20



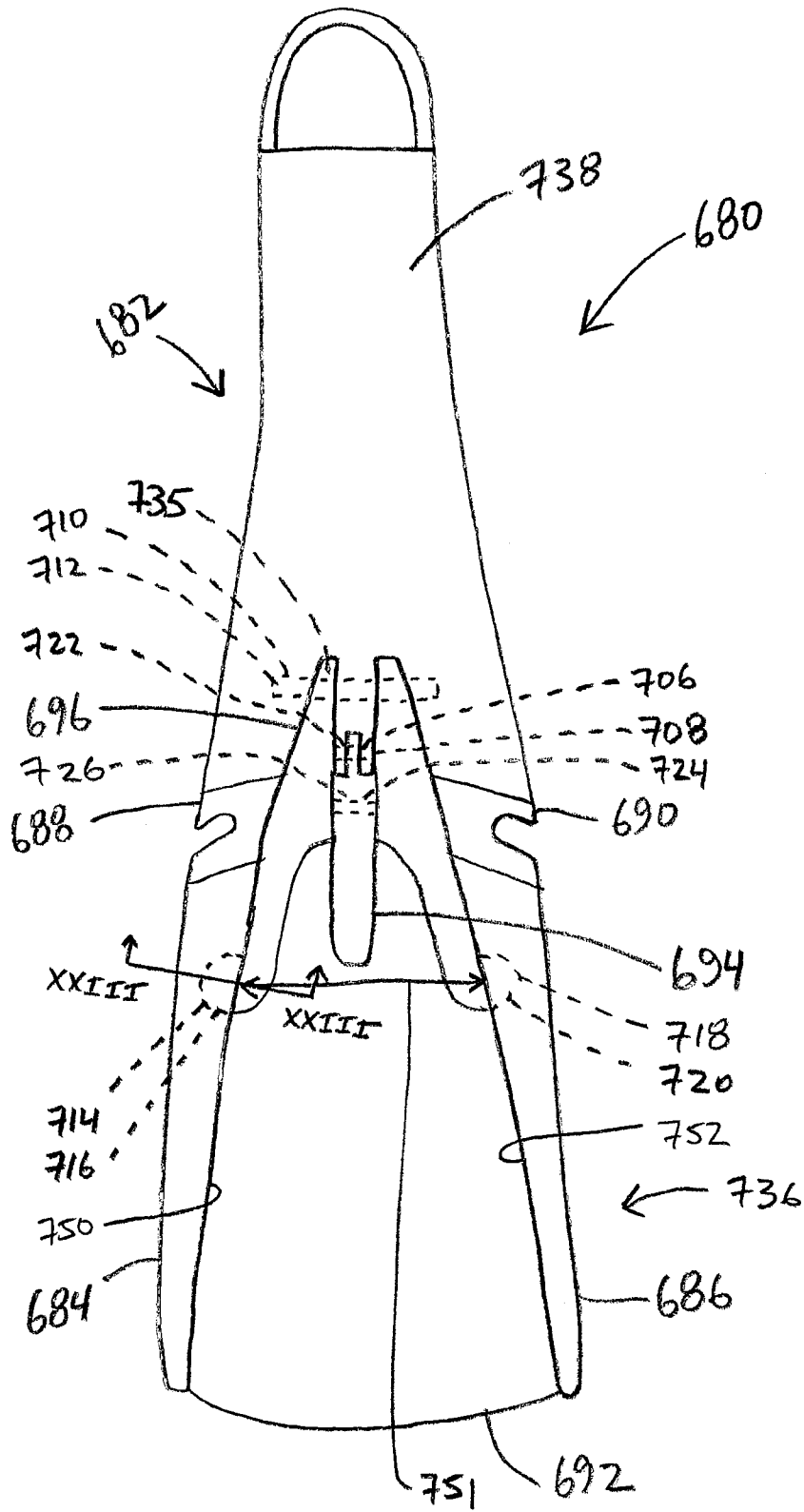

FIG. 22

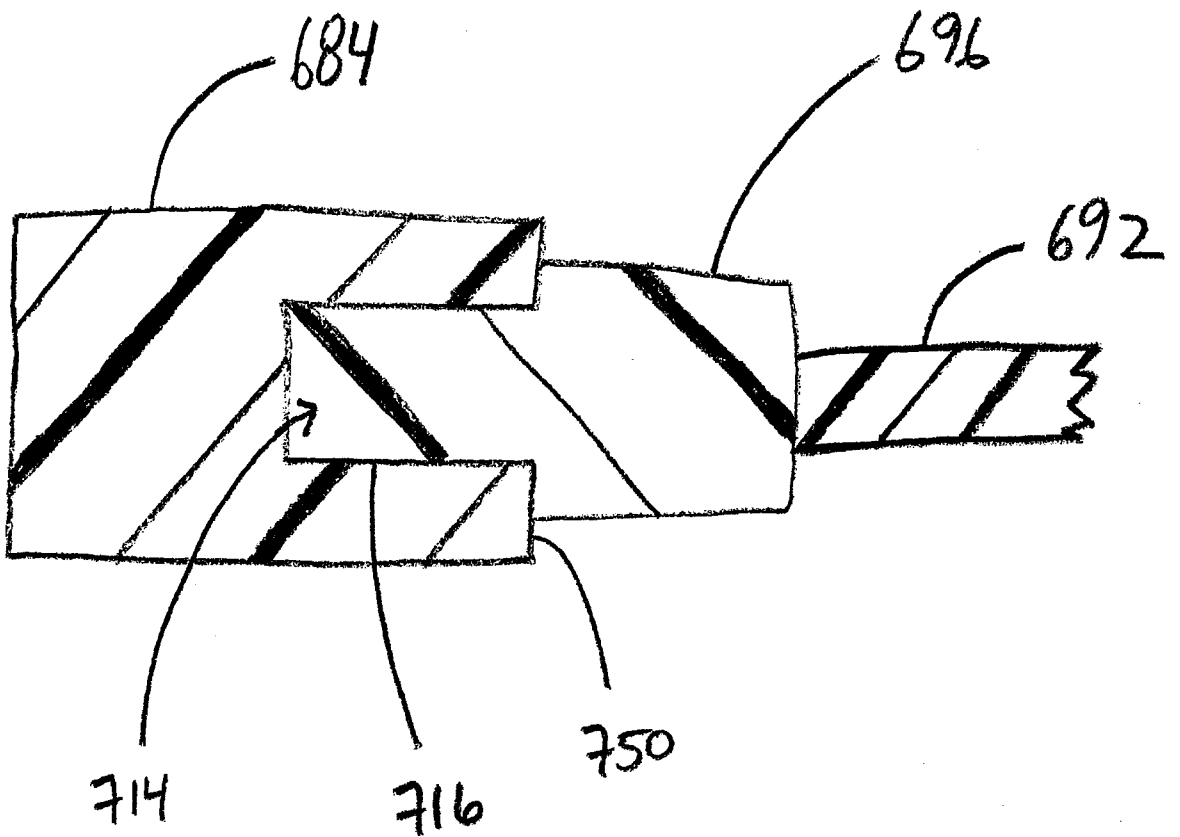

FIG. 23

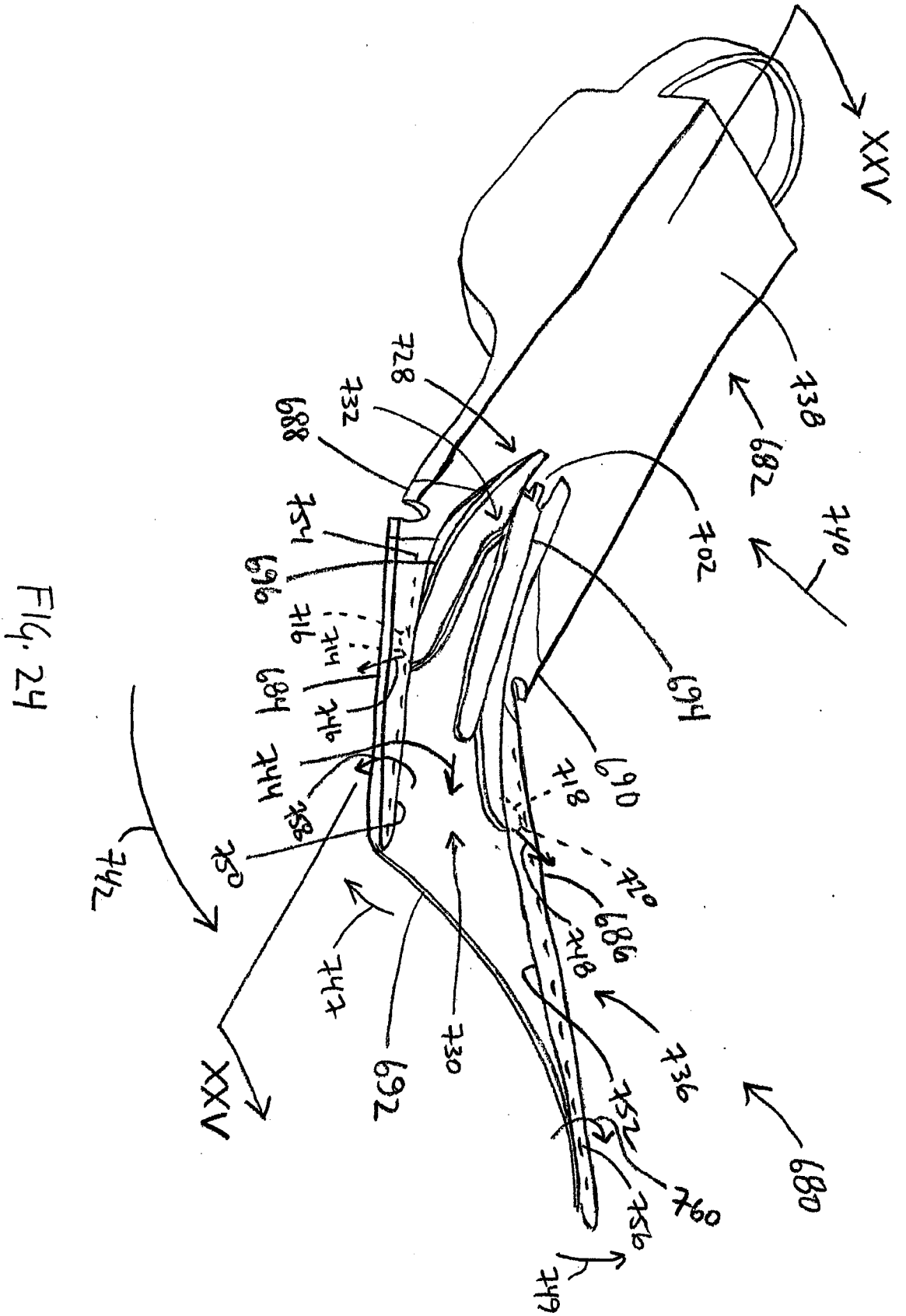
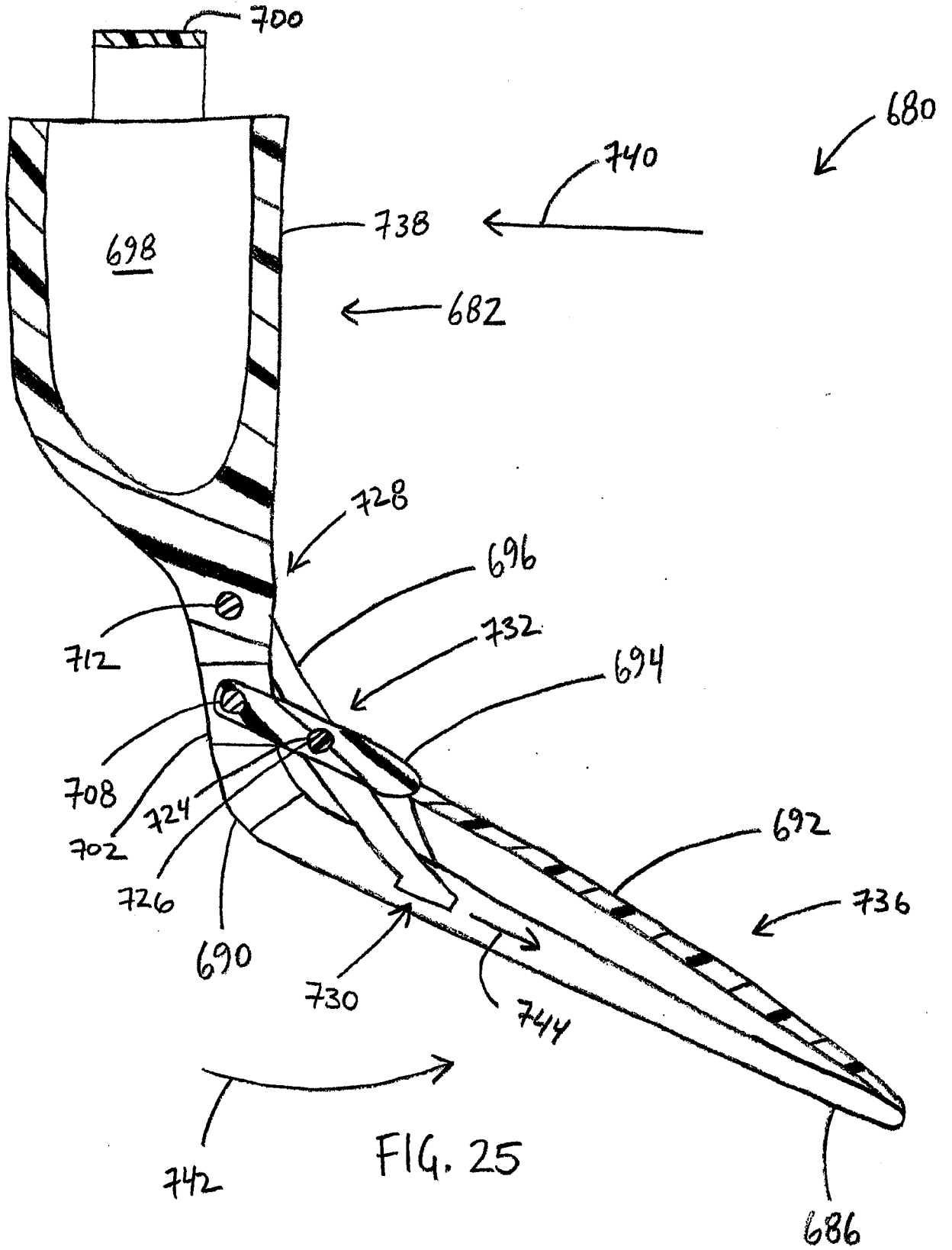

FIG. 24



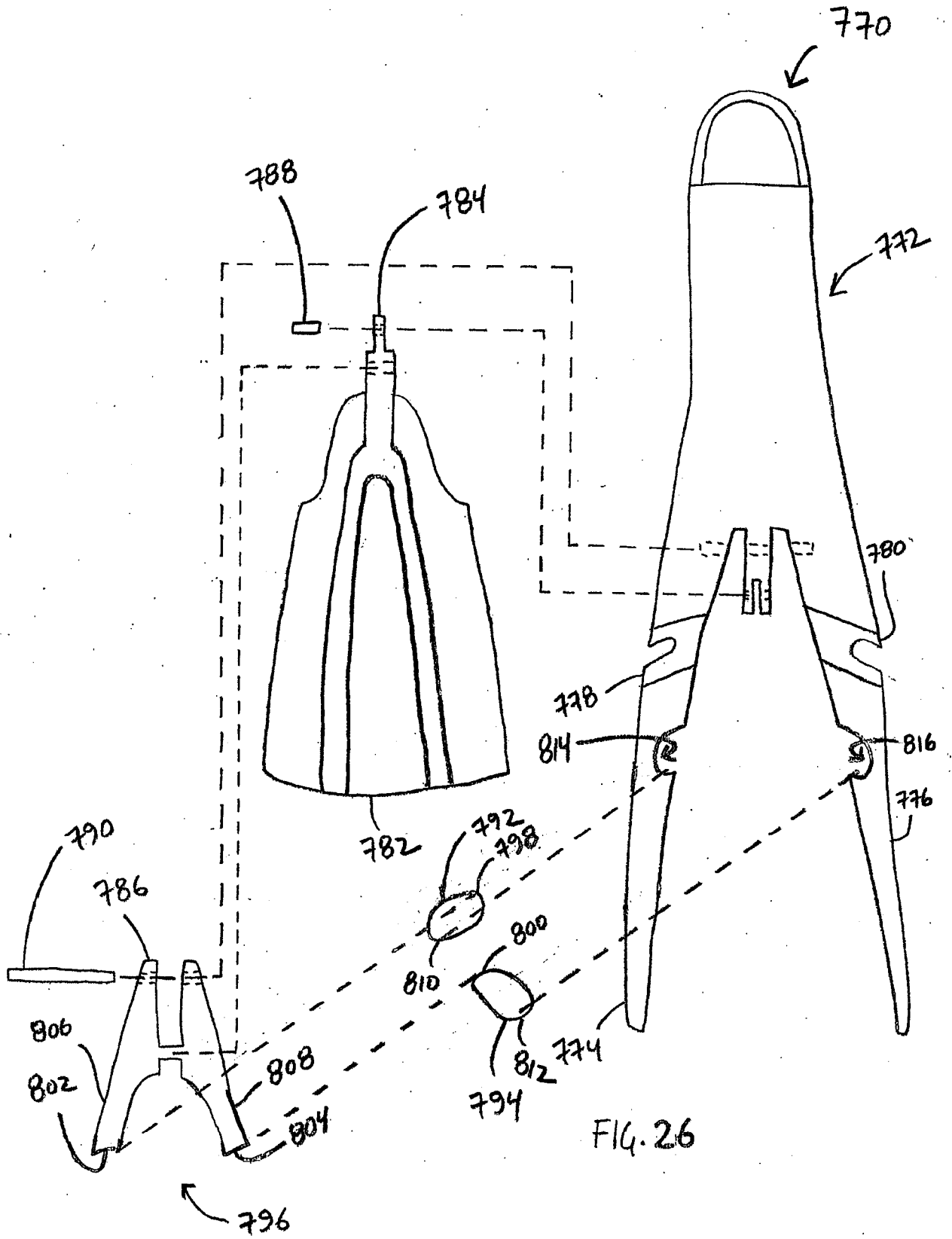
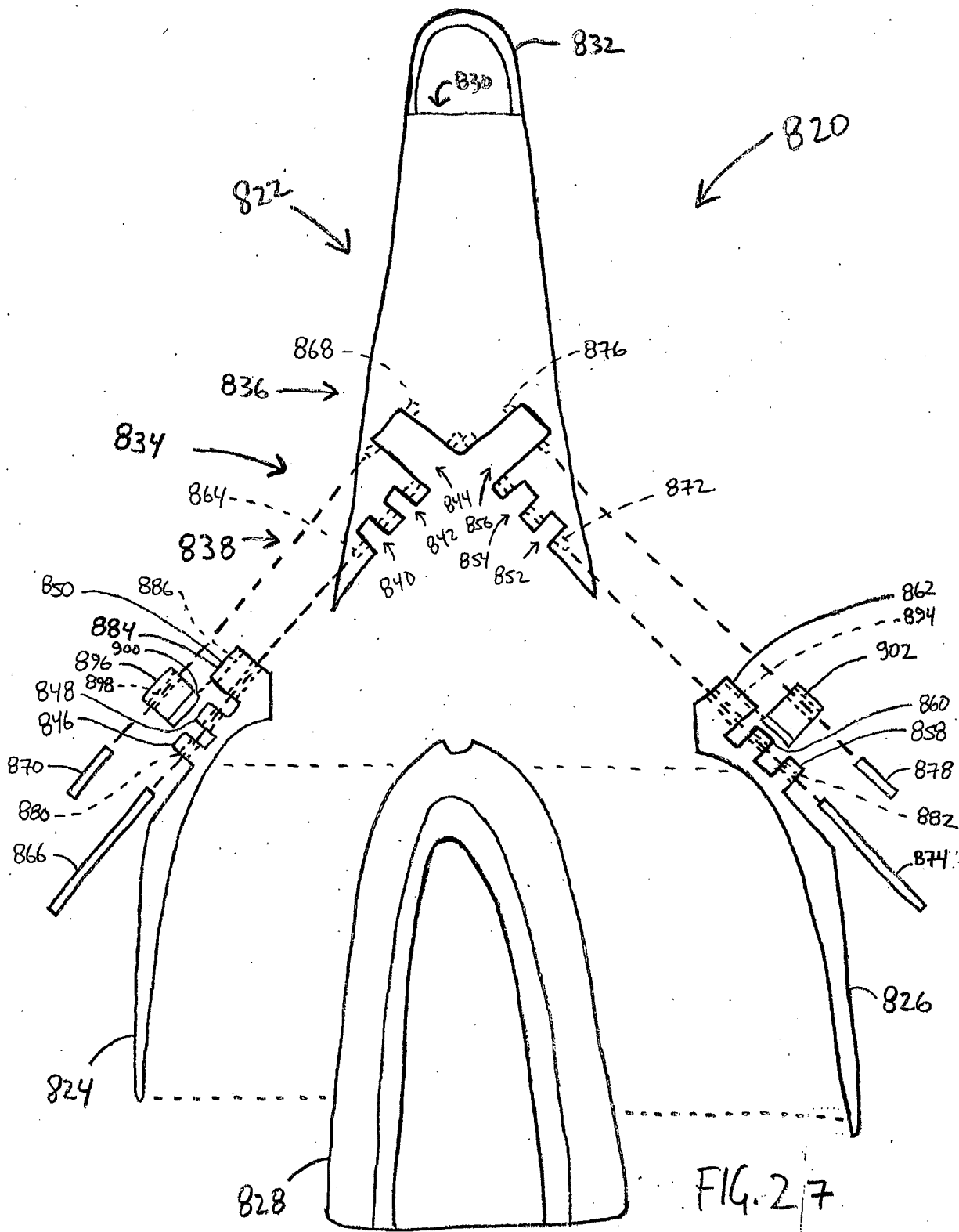

FIG. 26

27/42



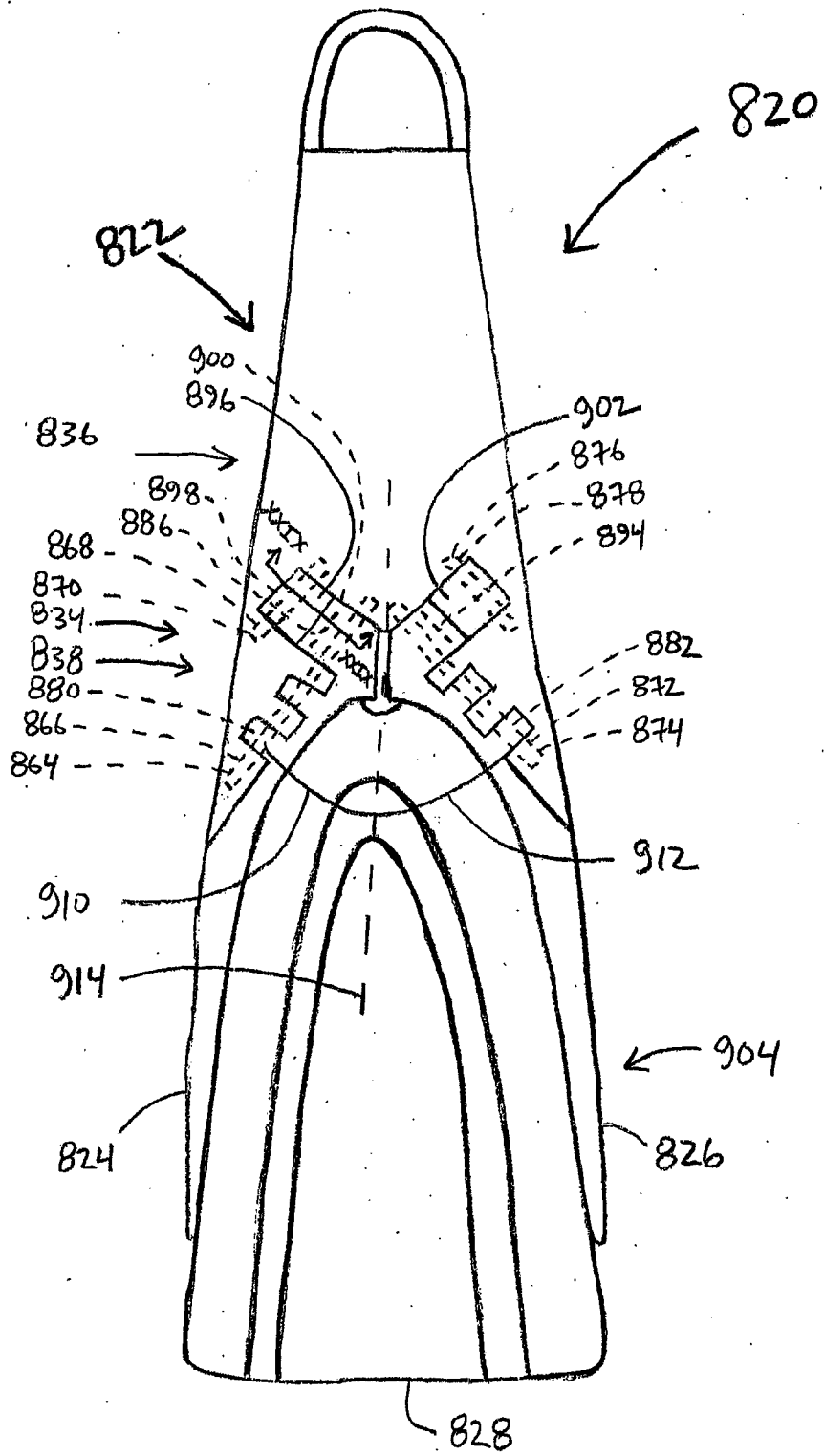

FIG. 28

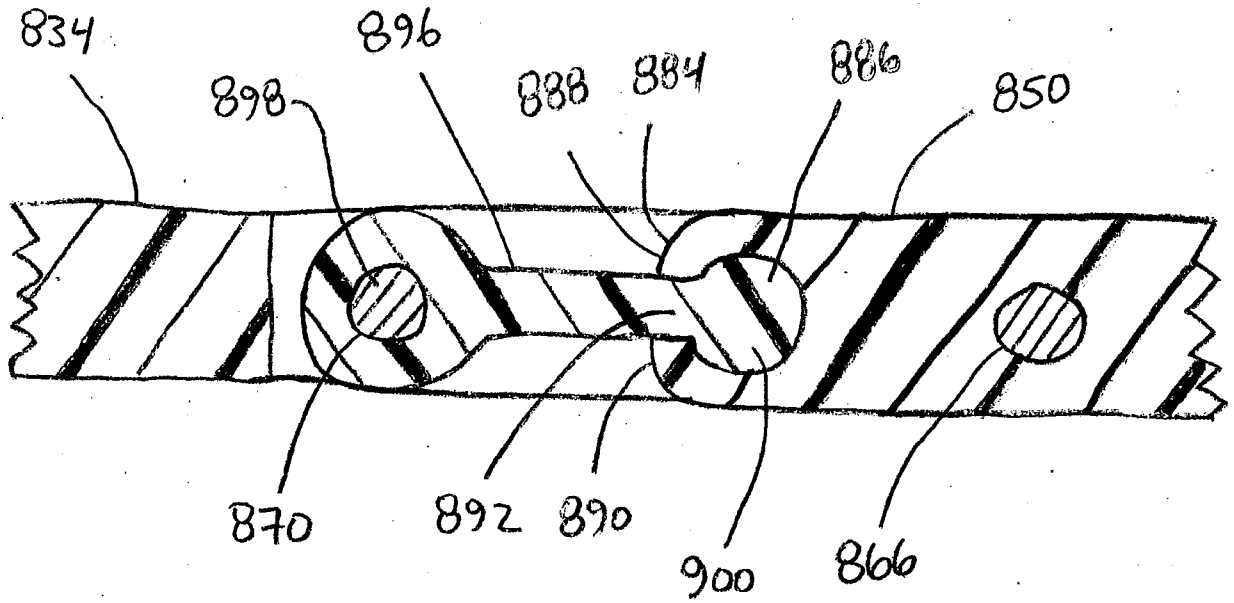

FIG. 29

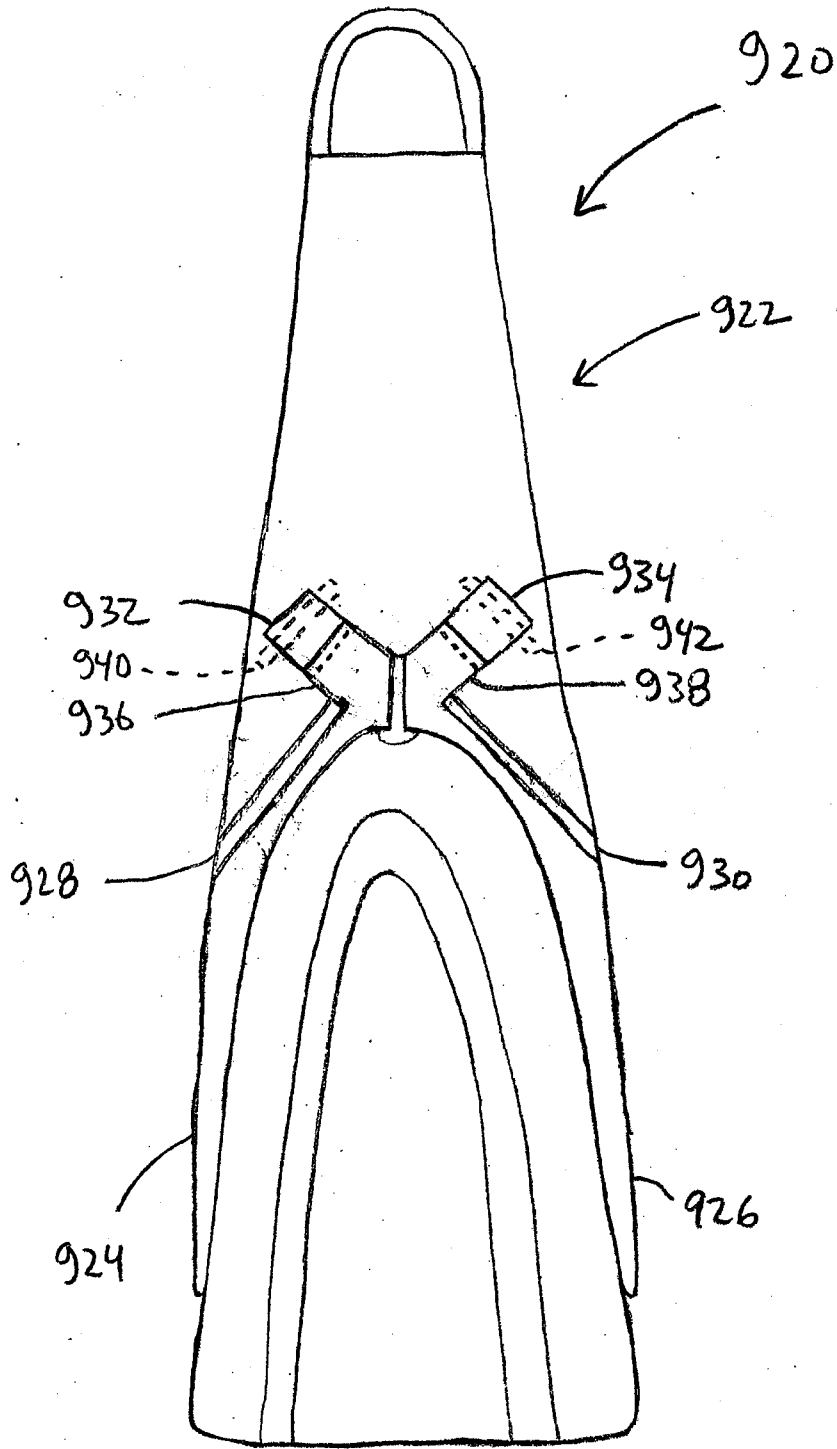

FIG. 31

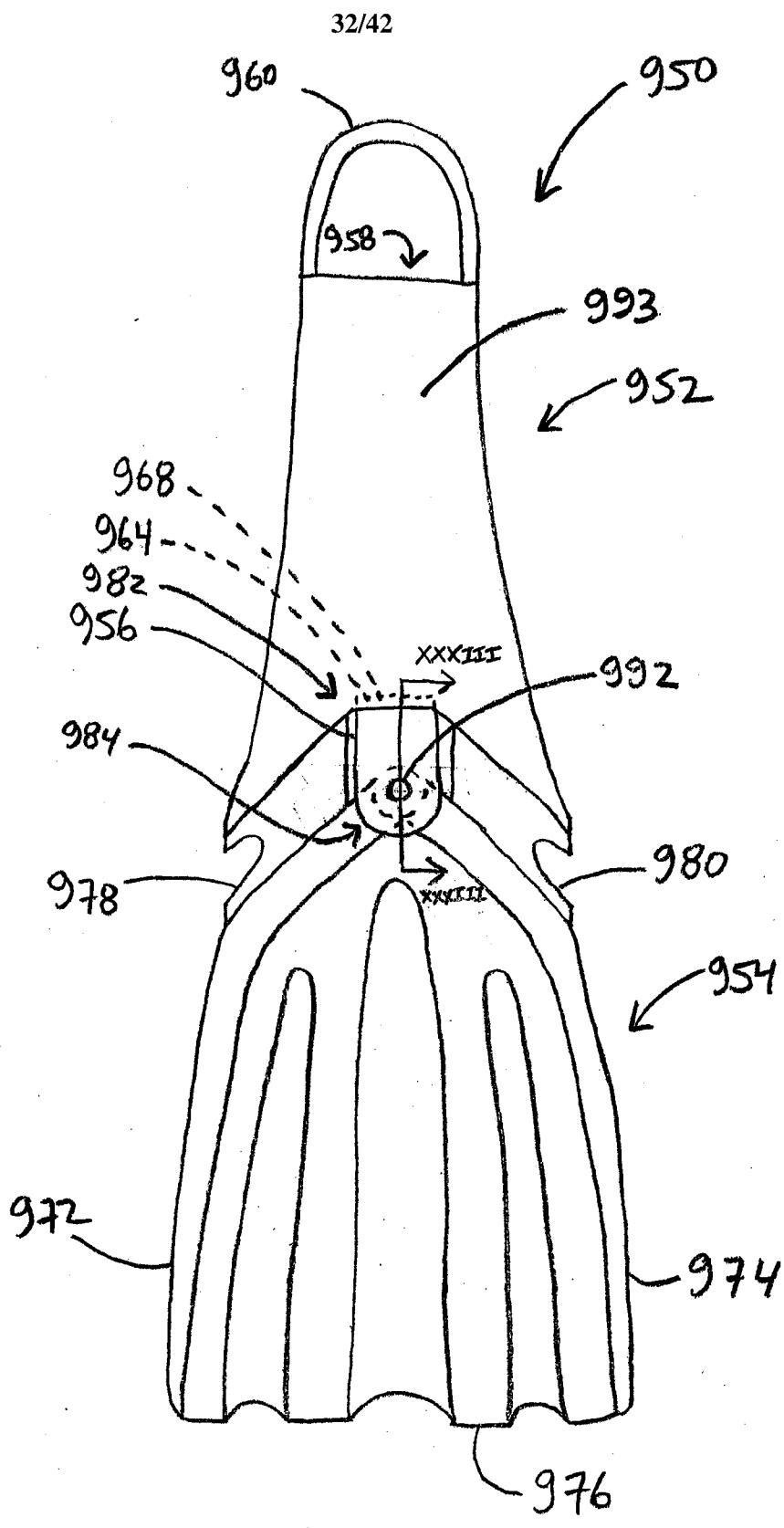

FIG. 32

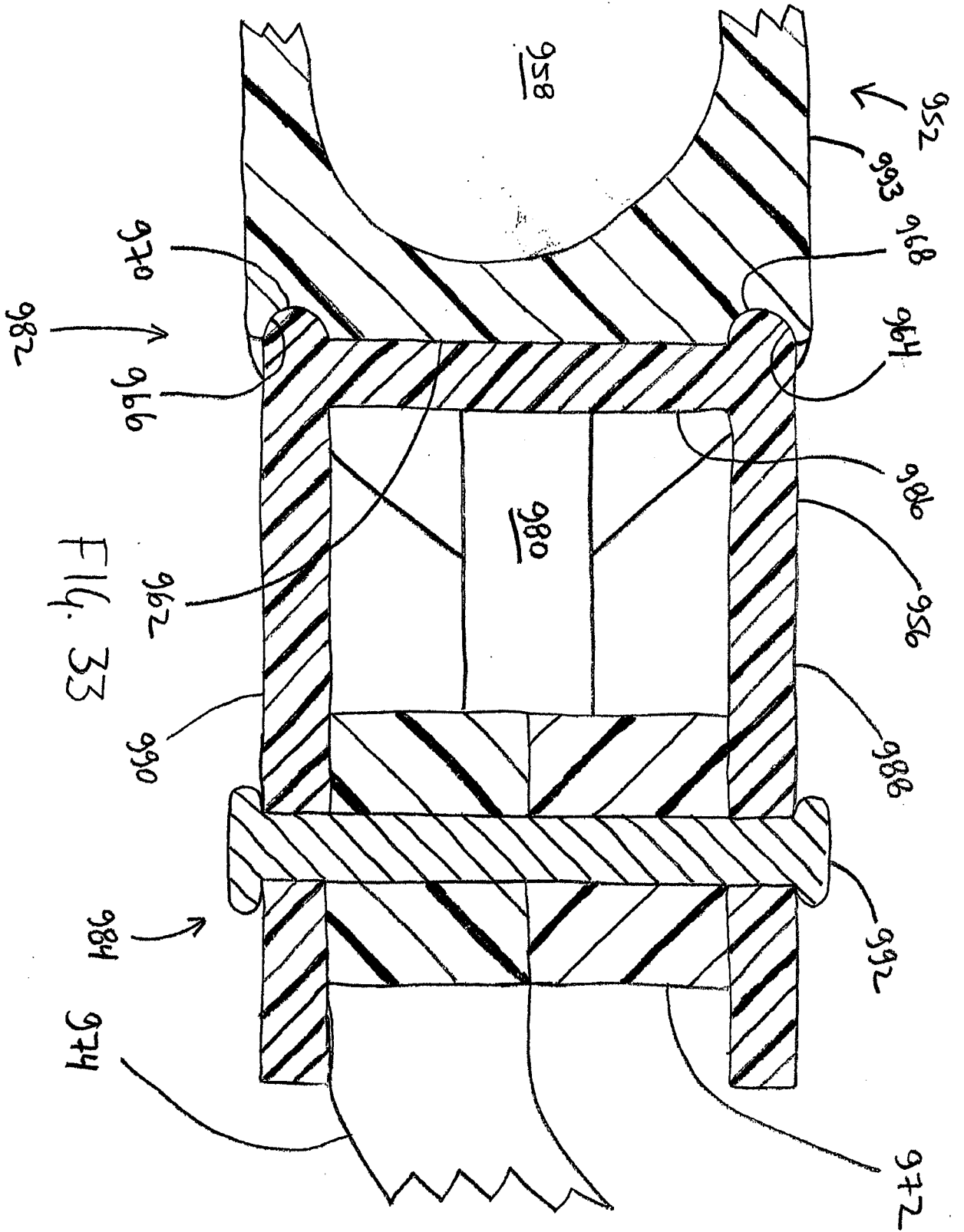
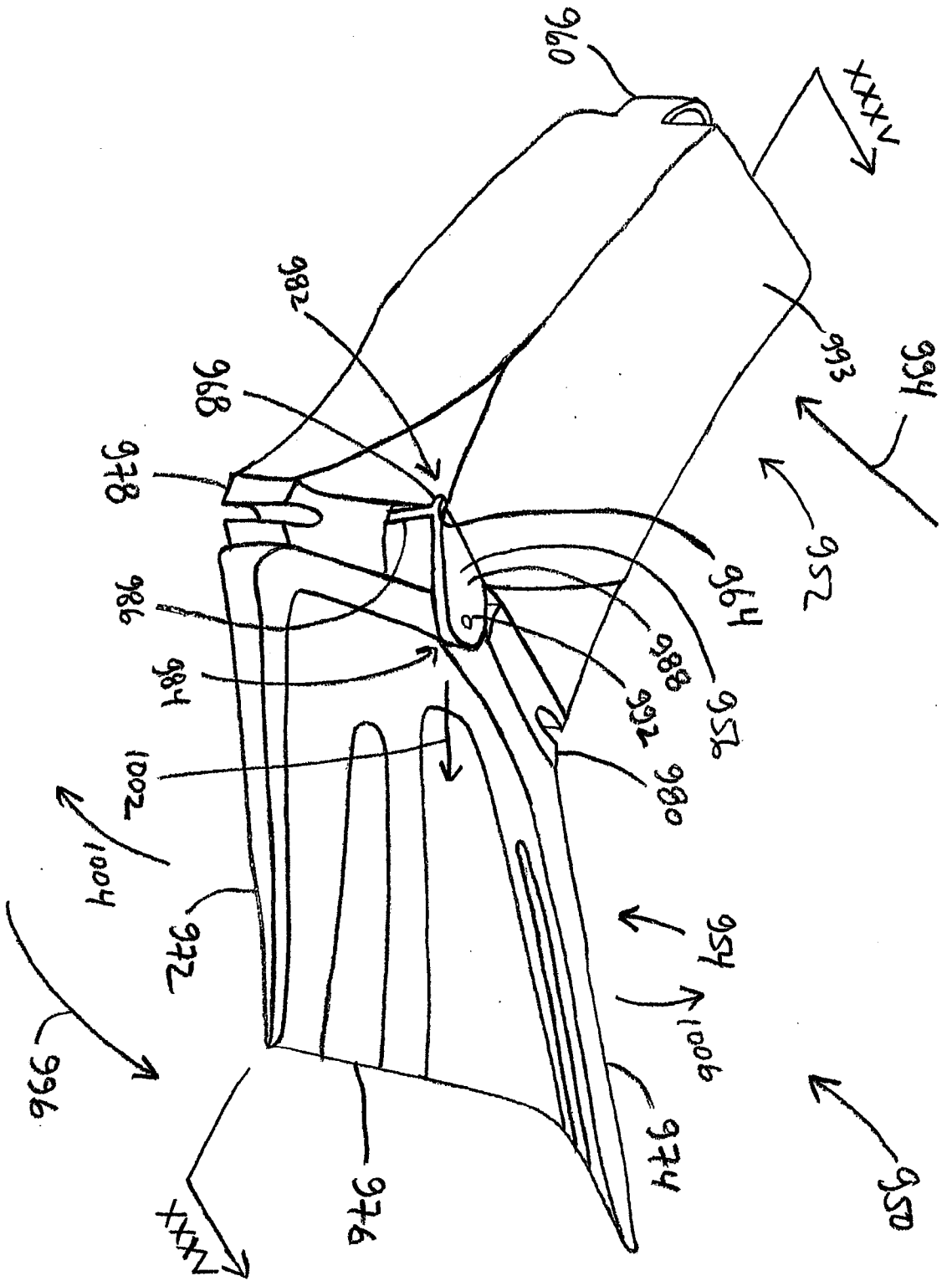

FIG. 33

FIG. 34



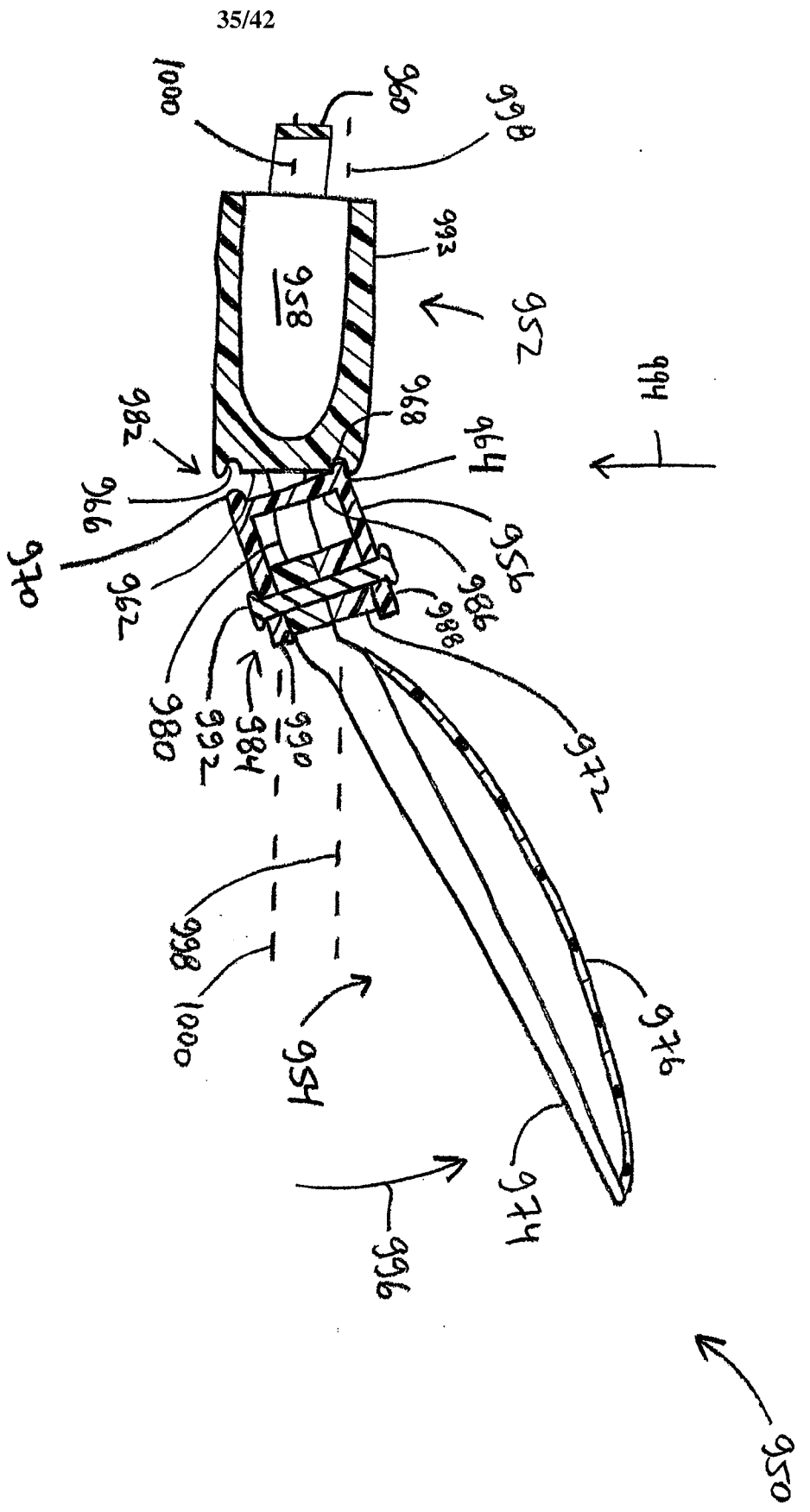
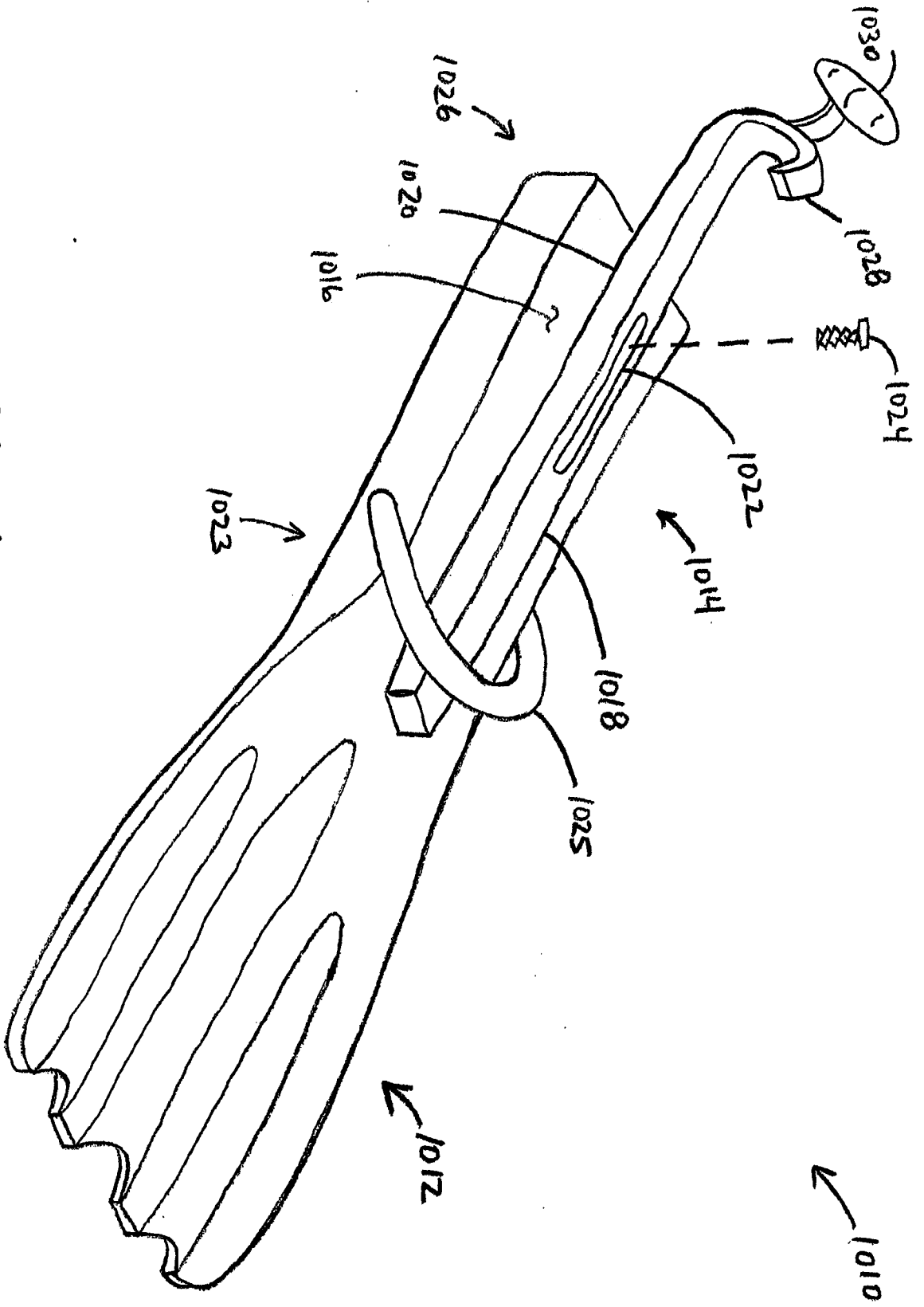

FIG. 35

36/42

FIG. 3.6



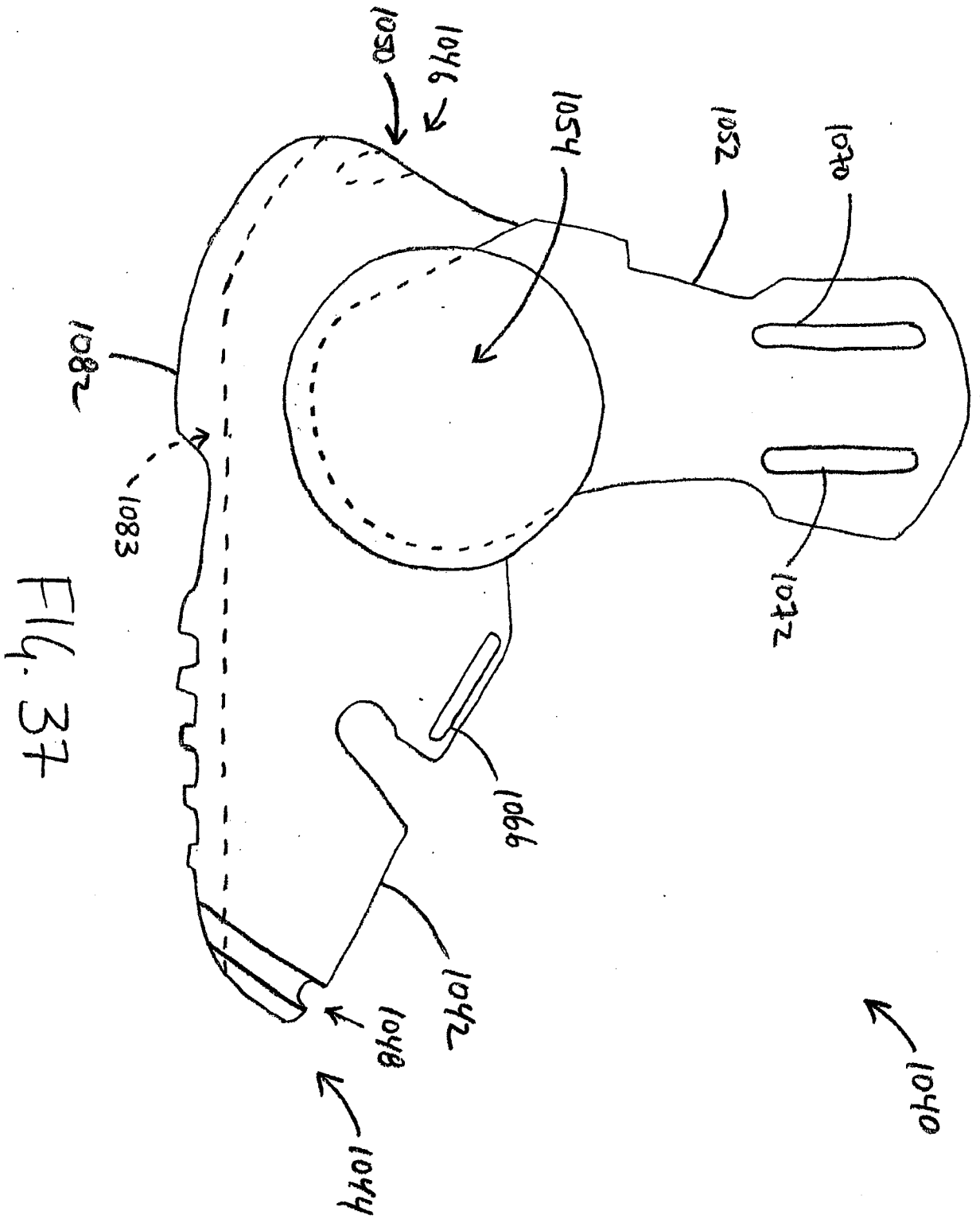

FIG. 37

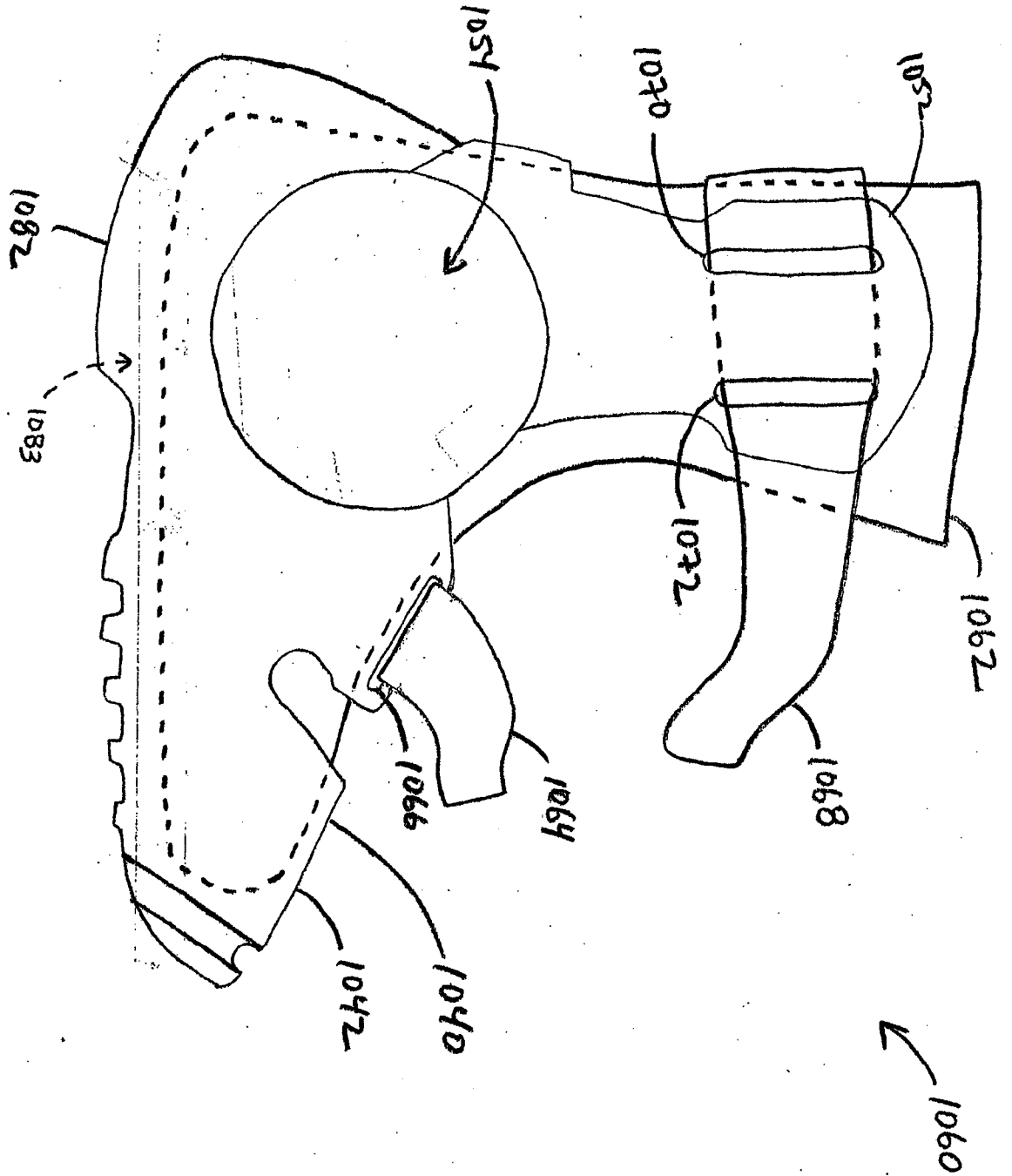
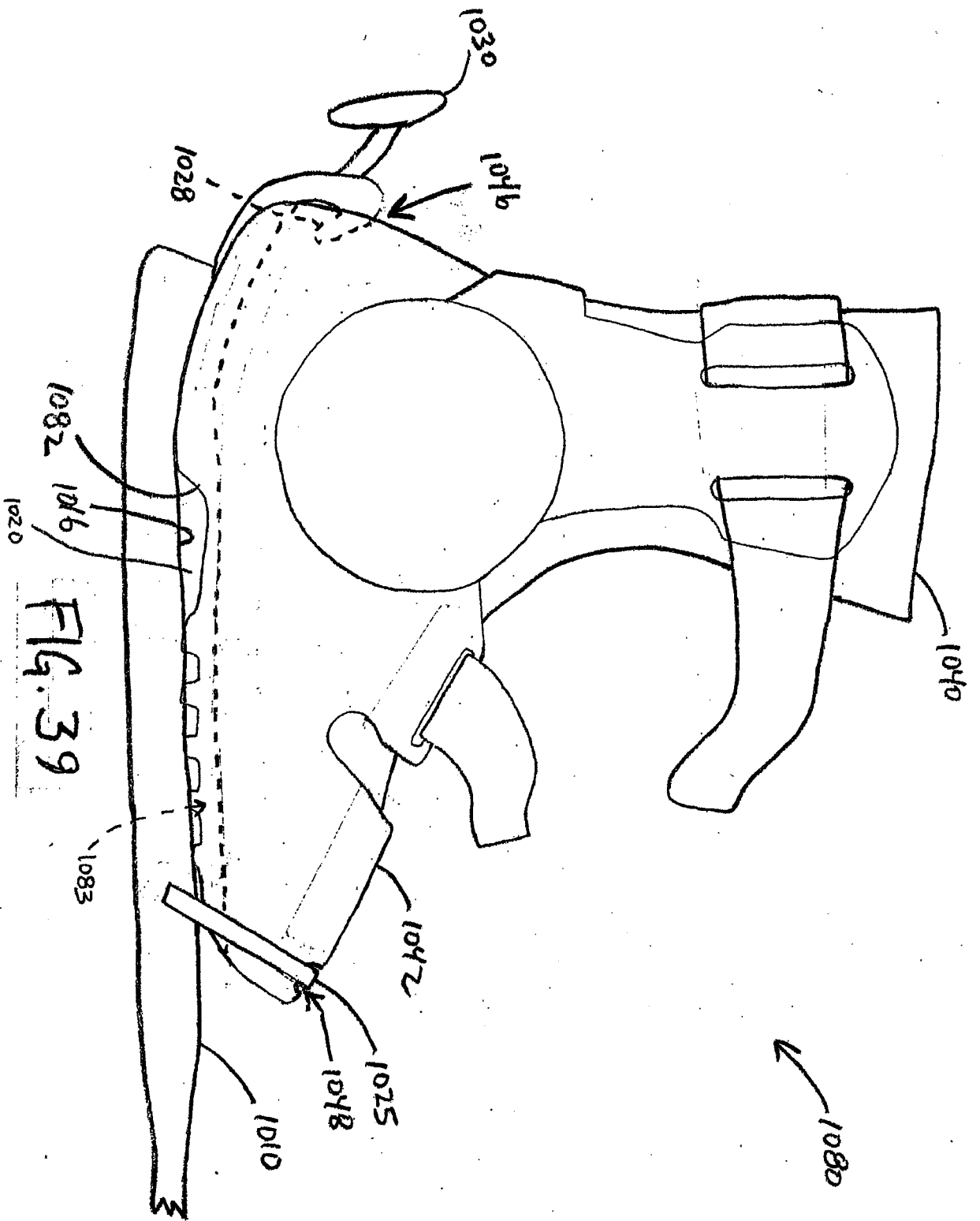

FIG. 38



1020

FIG. 39

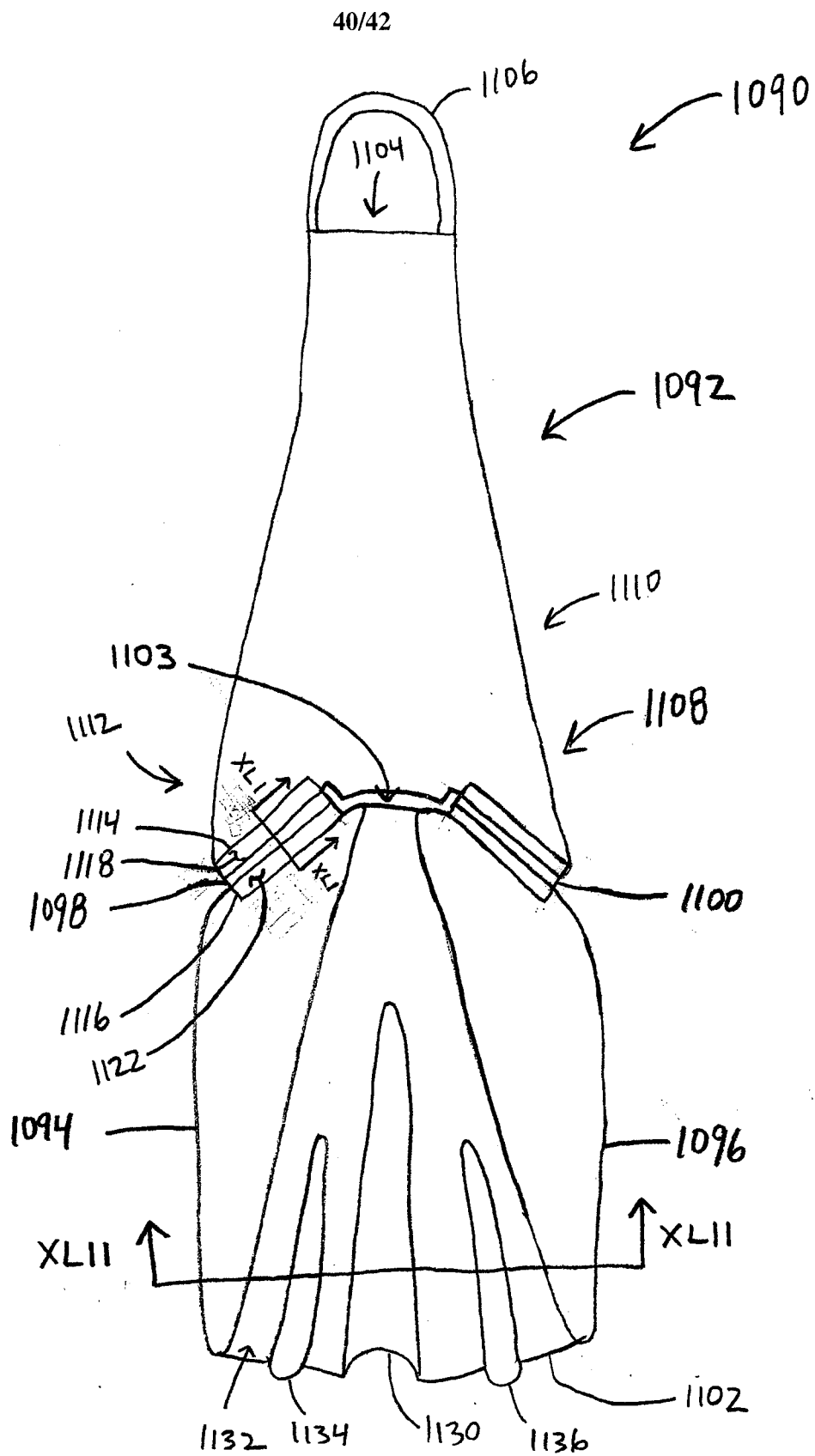

FIG. 40

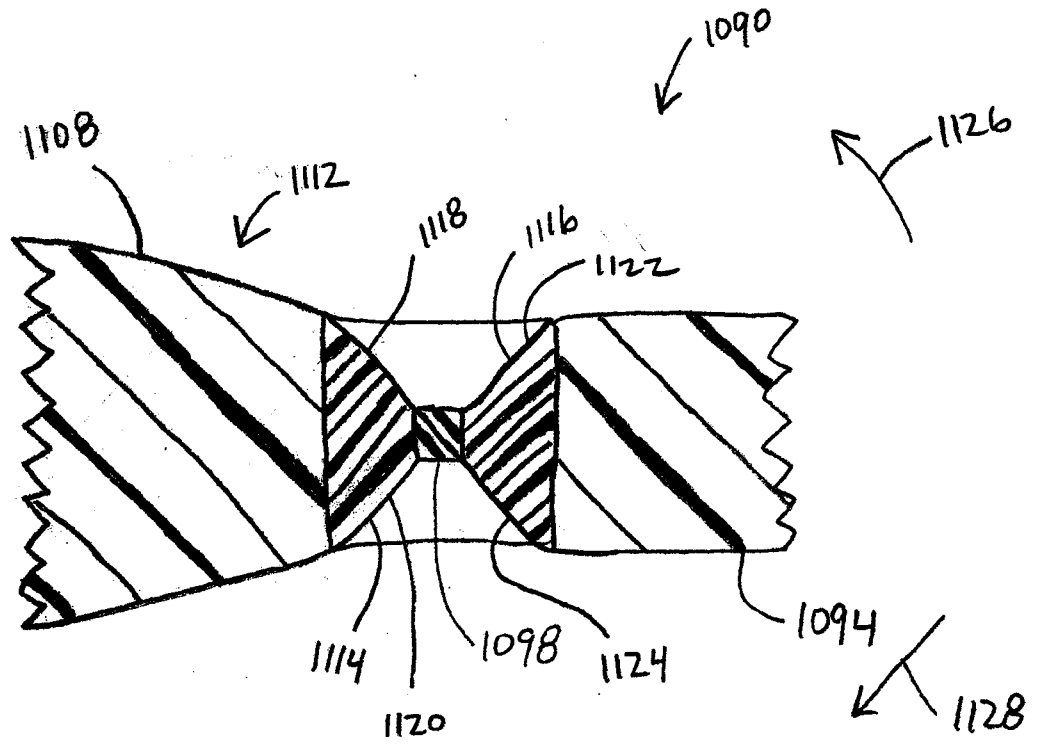

FIG. 41

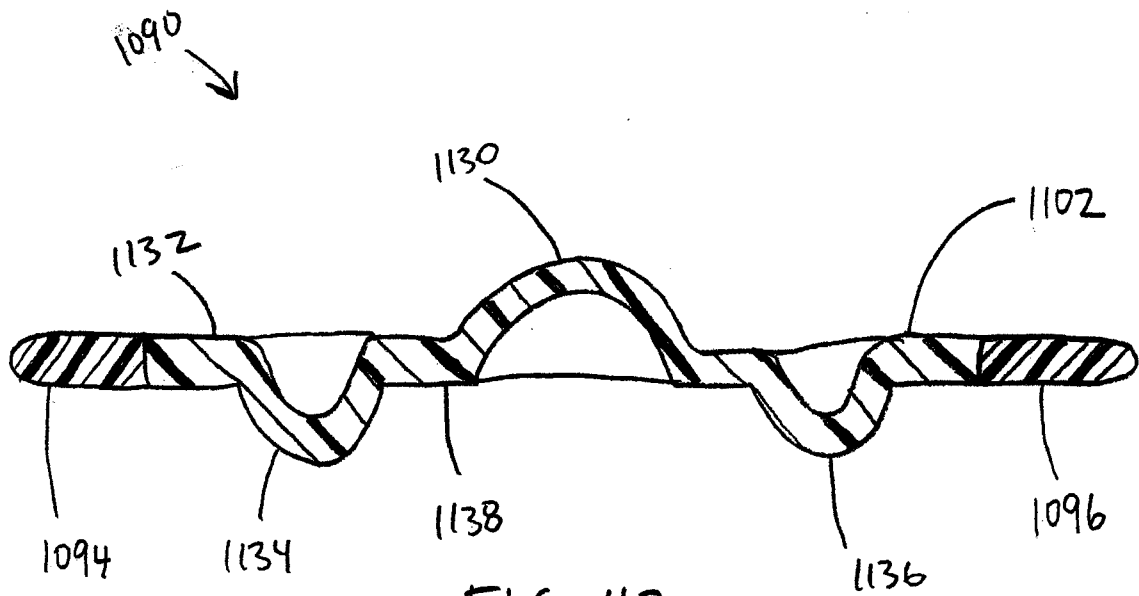

FIG. 42

