

(19) World Intellectual Property Organization  
International Bureau



(43) International Publication Date  
14 December 2006 (14.12.2006)

PCT

(10) International Publication Number  
**WO 2006/131868 A2**

- (51) International Patent Classification:  
A47J 43/07 (2006.01)
- (21) International Application Number:  
PCT/IB2006/051775
- (22) International Filing Date: 2 June 2006 (02.06.2006)
- (25) Filing Language: English
- (26) Publication Language: English
- (30) Priority Data:  
05105117.5 10 June 2005 (10.06.2005) EP
- (71) Applicant (for all designated States except US): **KONINKLIJKE PHILIPS ELECTRONICS N.V.** [NL/NL]; Groenewoudseweg 1, NL-5621 BA Eindhoven (NL).
- (72) Inventors; and
- (75) Inventors/Applicants (for US only): **LAMEIRO VILARINO, Jose, M.** [ES/NL]; C/o Prof. Holstlaan 6, NL-5656 AA Eindhoven (NL). **OBERSTEINER, Heimo** [AT/NL]; C/o Prof. Holstlaan 6, NL-5656 AA Eindhoven (NL).
- (74) Agents: **SCHOUTEN, Marcus, M.** et al.; Prof. Holstlaan 6, NL-5656 AA Eindhoven (NL).
- (81) Designated States (unless otherwise indicated, for every kind of national protection available): AE, AG, AL, AM, AT, AU, AZ, BA, BB, BG, BR, BW, BY, BZ, CA, CH, CN, CO, CR, CU, CZ, DE, DK, DM, DZ, EC, EE, EG, ES, FI, GB, GD, GE, GH, GM, HR, HU, ID, IL, IN, IS, JP, KE, KG, KM, KN, KP, KR, KZ, LC, LK, LR, LS, LT, LU, LV, LY, MA, MD, MG, MK, MN, MW, MX, MZ, NA, NG, NI, NO, NZ, OM, PG, PH, PL, PT, RO, RU, SC, SD, SE, SG, SK, SL, SM, SY, TJ, TM, TN, TR, TT, TZ, UA, UG, US, UZ, VC, VN, YU, ZA, ZM, ZW.
- (84) Designated States (unless otherwise indicated, for every kind of regional protection available): ARIPO (BW, GH, GM, KE, LS, MW, MZ, NA, SD, SL, SZ, TZ, UG, ZM, ZW), Eurasian (AM, AZ, BY, KG, KZ, MD, RU, TJ, TM), European (AT, BE, BG, CH, CY, CZ, DE, DK, EE, ES, FI, FR, GB, GR, HU, IE, IS, IT, LT, LU, LV, MC, NL, PL, PT, RO, SE, SI, SK, TR), OAPI (BF, BJ, CF, CG, CI, CM, GA, GN, GQ, GW, ML, MR, NE, SN, TD, TG).

[Continued on next page]

(54) Title: BLENDER ARM AND FOOD PROCESSOR

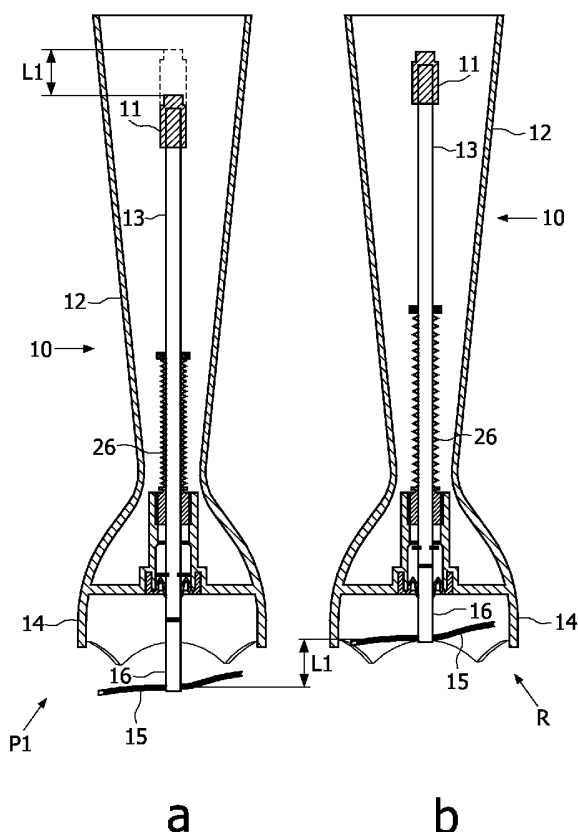

(57) Abstract: A blender arm (10) is proposed having a tubular body (12) equipped at one end with a connection (11) for a power unit, including axially a rotary shaft (13) including a tool (15) at the end opposite to the connection end, around which tool (15) a peripheral protection (14) is established, wherein the rotary shaft (13) with the tool (15) is attached movably in axial direction to the tubular body (12) so that the tool (15) may be positioned in a retracted position (R) for operation or a protracted position (PI) for cleaning, without having to touch the tool (15) with the hands. Preferably, the blender arm (10) comprises a resilient element (27) functionally connected to the tubular body (12) and the rotary shaft (13), for moving the rotary shaft (13) from the protracted (PI) to the retracted position (R) of the tool (15). Then, as soon as one releases the rotary shaft (13), the tool (15) automatically returns to the retracted position (R).

WO 2006/131868 A2



**Declaration under Rule 4.17:**

— *as to applicant's entitlement to apply for and be granted a patent (Rule 4.17(ii))*

*For two-letter codes and other abbreviations, refer to the "Guidance Notes on Codes and Abbreviations" appearing at the beginning of each regular issue of the PCT Gazette.*

**Published:**

— *without international search report and to be republished upon receipt of that report*

## Blender arm and food processor

The present invention relates to a blender arm having a tubular body equipped at one end with a connection for a power unit, including axially a rotary shaft with a tool at the end opposite to the connection end, around which tool a peripheral protection is established, as well as to a food processor with such a blender arm.

5

Food processors with a blender arm are often used for chopping, pureeing, grinding, mincing or mixing, for example when making soups, sauces, drinks etc.. During this process, sometimes some residues, e.g. food fibers get stuck in the area behind the  
10 blending tool. The usual way to clean the blender arm is to put the end with the tool and the peripheral protection under a flush of water. Often, this is not enough to totally remove the residues. Since there is no direct access to the area behind the tool, a thorough cleaning is difficult.

EP 1 407 701 A1 describes a grinding or mincer arm with a removable end for  
15 cleaning purposes. The mincer arm is connected in a removable way with respect to an operation motor block of a manual electric household appliance, being applied for example for the preparation of food. The arm includes a rotary shaft, at whose end a tool is situated, which can vary as a function of the operations for which the appliance is meant. A peripheral incorporated protection for the tool is made up of an independent piece situated in detachable  
20 connection. The rotary transmission shaft incorporates at the end an extension piece connected by means of fitting with free extraction, and holding the tool. For thorough cleaning, the arm is disassembled by removing the peripheral protection and extracting the extension piece with the tool.

The mincer arm described in EP 1 407 701 A1 has the disadvantage that the  
25 tool has to be touched when disassembling and reassembling the arm. This can be quite dangerous in case the tool is a blade or knife.

Accordingly, it is an object of the present invention to provide a blender arm that is less dangerous to handle when cleaning it, and a food processor with such an arm respectively.

In a first aspect of the present invention, this object is achieved by a blender arm having a tubular body equipped at one end with a connection for a power unit, including axially a rotary shaft including a tool at the end opposite to the connection end, around which  
5 tool a peripheral protection is established, wherein the rotary shaft with the tool is attached movably in axial direction to the tubular body, so that the tool may be positioned in a retracted position – suited for operation – or a protracted position – suited for cleaning.

The distinction between retracted and protracted position is to be seen with  
10 respect to the peripheral protection. In a retracted position, the tool is inside the peripheral protection, thus ensuring safe operation. In a protracted position, the tool is outside the peripheral protection, thus ensuring an easy and thorough cleaning by holding the tool under a water flush, because the water easily reaches the area behind the tool. By doing so, the part of the rotary shaft near the tool and outside the tubular body is cleaned as well, thus avoiding  
15 that residues enter the inner part of the tubular body.

The blender arm according to the present invention has the advantage that it can be cleaned without any need of directly touching the tool. Especially, if the tool includes a blade or a knife, the danger of injuring oneself, when trying to clean the blender arm, is reduced significantly. Furthermore, the cleaning may be done much faster without having to  
20 disassemble and reassemble the blender arm.

There are many possibilities to actuate the rotary shaft to change the position of the tool. In embodiments where the blender arm is removably connected to a power unit, the simplest possibility is to push the rotary shaft on the connection side to move the tool from a retracted to a protracted position.

25 In other embodiments, e.g. if the blender is irremovably connected with the part of a food processor containing the power unit, or if cleaning will be possible without removing the blender arm, or if the handling will be simplified, the rotary shaft is functionally connected to an actuating element designed as part of the tubular body and moving the rotary shaft in axial direction from the retracted position to the protracted position  
30 of the tool. This actuating element may be for example a push button or a movable ring connected to the rotary shaft and moving it in axial direction.

In preferred embodiments, the rotary shaft with the tool is attached movably in axial direction to the tubular body, so that the tool returns automatically from the protracted position to the retracted position. This has the advantage, that the user does not have to

particularly handle the rotary shaft with tool by e.g. pushing or drawing it manually back to the retracted position, thus considerably reducing the danger of injuring himself with the tool.

Preferably, the blender arm further comprises a resilient element functionally connected to the tubular body and the rotary shaft for moving the rotary shaft from the  
5 protracted position to the retracted position of the tool. This has the considerable advantage that, as soon as one releases the rotary shaft directly or the actuating element, the tool automatically returns to the retracted position. The probability of inadvertently touching the tool and injuring oneself is even more reduced.

In other preferred embodiments, the blender arm further comprises a locking  
10 device locking the tool in the protracted position for the sake of more convenient handling. This avoids the necessity of holding the rotary shaft or the actuating element with one's finger in the protracted position during the whole cleaning.

In some preferred embodiments, the tool is releasably attached to the rotary shaft, wherein release is possible in the protracted position, thus allowing exchange of the  
15 tool to sharpen it or replace it with a new one. In this case, it is advantageous to provide a locking device to reduce the danger of injuries during exchange of the tool.

In some other preferred embodiments, the tool is releasably attached to the rotary shaft, too, but may be positioned in a second protracted position for release. Advantageously this second protracted position places the tool further outside the peripheral  
20 protection compared to the first protracted position to make the release of the tool easier.

In a further aspect of the invention, this object is achieved by a food processor with a power unit and a blender arm as explained connected to the power unit. The blender arm can be an integral part of the food processor or be removably attached to the part containing the power unit.  
25

Preferred embodiments of the food processor further comprise a safety switch device for controlling the tool's position and allowing operation in case the tool is positioned in retracted position. This removes the danger of operating the tool when it is not protected by the peripheral protection, and injuring persons or making a mess of a kitchen by splashing around the food to be processed.  
30

A detailed description of the invention is provided below. Said description is provided by way of a non-limiting example to be read with reference to the attached drawings in which:

Fig. 1a shows a first embodiment of the blender arm according to the present invention in a retracted position;

Fig. 1b shows the first embodiment of the blender arm according to the present invention in a protracted position;

5 Fig. 1c shows the first embodiment of the blender arm according to the present invention from below;

Fig. 2a shows a second embodiment of the blender arm according to the present invention in a protracted position;

10 Fig. 2b shows the second embodiment of the blender arm according to the present invention in a retracted position;

Fig. 3a shows a third embodiment of the blender arm according to the present invention in a protracted position;

Fig. 3b shows the third embodiment of the blender arm according to the present invention in a retracted position;

15 Fig. 4a shows a fourth embodiment of the blender arm according to the present invention in a retracted position;

Fig. 4b shows the fourth embodiment of the blender arm according to the present invention in a protracted position;

20 Fig. 5a shows a first embodiment of a hand blender according to the present invention;

Fig. 5b shows a second embodiment of a hand blender according to the present invention;

Fig. 5c shows a third embodiment of a hand blender according to the present invention;

25 Fig. 5d shows a fourth embodiment of a hand blender according to the present invention; and

Fig. 6 shows an embodiment of a hand mixer with a blender arm according to the present invention.

30

Figures 1a,b,c show a first embodiment of a blender arm 10 according to the present invention, Figures 1a and 1b as cut in axial direction and Figure 1c from below. The main components are a tubular body 12 including a rotary shaft 13. At the lower end (as shown in Figure 1), the tubular body 12 is enlarged to form a cage 14 as peripheral protection

around the blade 15, fixed at the lower end of the rotary shaft 13. The upper end of the rotary shaft 13 shows a connection 11 to connect the rotary shaft 13 to a power unit (not shown) to induce it into rotation to operate the blade 15. The rotating blade 15 then chops or purees or mixes what is surrounding it.

5           The rotary shaft 13 is held inside the tubular body 12, so that it can be moved in axial direction by pushing, e.g. with the finger onto the connection 11, so that the blade 15 moves over a length L1 from a retracted position R inside the cage 14 (Figure 1a) to a protracted position P1 outside the cage 14 (Figure 1b). In contrast to position R, position P1 allows to easily wash the lower part of the blender arm 10 even behind the blade 15 to  
10 thoroughly remove any residues, as well as the lower end of the rotary shaft 13. As the blade 15 is moved to its protracted position P1 just by pushing the rotary shaft 13 at the other end, there is no need to touch the blade 15 itself for cleaning.

          By moving the rotary shaft 13 with the blade 15 from position R to position P1 the pneumatic resilient element 27 is compressed. One could also use resilient elements based  
15 on liquids or any other resilient elements known in the art.

          Due to the pneumatic resilient element 27, one should press the connection 11 during the whole cleaning process to keep the blade 15 in position P1. As one stops pressing, the pneumatic resilient element 27 immediately decompresses and moves the rotary shaft 13 and with it the blade 15 automatically back from position P1 to position R inside the cage 14.  
20 This reduces the danger of inadvertently touching the blade 15 during or after the cleaning. It will be noted, that an automatic movement back to the retracted position R may be achieved by more complex means as well, e.g. by using a motor.

          Compared to blender arms according to the state of the art, no time-consuming and dangerous disassembling and reassembling is necessary to clean the blender arm 10  
25 according to the present invention. Furthermore, there are no loose parts that could get lost.

          Figures 2a,b show another embodiment of the blender arm 10 according to the present invention. The pneumatic resilient element has been replaced by a metal spring 26 that is expanded, when the blade 15 is in the retracted position R, and compressed, when the blade 15 is in the protracted position P1. Furthermore, the blade 15 is fixed to the blade shaft  
30 16, which in turn is releasably attached to the rotary shaft 13. The blender arm 10 of Figures 2a,b gives the possibility of removing the blade 15 with blade shaft 16 for sharpening or exchanging it with a new one, when the blade 15 is in position P1.

          In a further embodiment with releasable blade 15, as shown in Figures 3a,b, removing of the blade 15 with blade shaft 16 is possible only in a further protracted position

P2, where the blade 15 is further outside the cage 14, i.e. the rotary shaft 13 has been moved over a length L2 larger than L1. This avoids for example random loosening of the blade shaft 16 during cleaning.

Figures 4a,b show embodiments of the blender arm 10 according to the present invention with various safety switches 30, 40, 50 that make sure that the blade 15 is not operated in the protracted position P1, which could be dangerous and a nuisance if the food to be processed is splashed around. These possibilities are to be taken as examples only. Any kind of appropriate safety switch known in the art can be used as well.

One possibility for a safety switch 30 is shown in Figure 4a. There, the connection 11 cooperates with a mechanical switch 31 in the motor block connection 61 inside the housing 62 of a power unit part of a food processor. If the connection 11 is inserted into the motor block connection 61, it presses onto the mechanical switch 61 and thus allows the motor block to be powered, in case the general switch of the food processor is switched on.

Two further possibilities of safety switches 40, 50 are illustrated in Figure 4b. The safety switch 40 is based on a magnetic approach. The connection 41 is made of magnetic material. The magnetic switch 42 on the inner side of the tubular body 12 measures the magnetic field (broken line) of the magnetic connection 41. If a certain magnetic field is reached, because the magnetic connector 11 is near enough to the magnetic switch 42, i.e. the blade 15 in a retracted position R, a corresponding signal is transmitted to some power control of the food processor allowing the motor block to be powered, if desired.

The safety switch 50 is an optical one. There is a mark 53 on the rotary shaft 13 indicating the blade 15 which is in the retracted position R. By means of a light emitter 51 (light symbolized by broken line), e.g. a light emitting diode, and a detector 52, e.g. a photo diode, it can be detected whether the right position is reached or not, and corresponding signals are sent to some power control of the food processor.

Figures 5a to 5d show different embodiments of a hand blender 1 with a blender arm 10 according to the present invention. To simplify the handling during cleaning, various actuating elements are provided. The actuating elements are connected to the rotary shaft inside the tubular body by conventional means, e.g. mechanical means, to translate the movement of the actuating element into an appropriate movement of the rotary shaft in axial direction. The blender arm 10 is attached to a power unit part 6 of the hand blender 1. The hand blender 1 is switched on and off by means of the switch 63.

The embodiment of Figure 5a has a button 21 that has to be pushed and held to get the blade into a protracted position and stay in it during cleaning. If the button 21 is released, the blade moves automatically back to a retracted position due to a resilient element, as explained before. It will be noted that in view of the cage 14 having openings, it could be enough to move the blade, for safety reasons, only up to the height of the openings of the cage for cleaning, but it would be more complicated to reach the same cleaning result as with a blade outside the cage 14.

The embodiment illustrated in Figure 5b shows a ring 24 instead of the button 21. The ring has to be turned to move the rotary shaft with the blade.

The embodiment of Figure 5c has a button 22 to be pushed along the guidance 23. The button 22 can be pushed into two different positions in which it can be locked by pushing it to the side against an edge 25, e.g. against the resilient force of any resilient element. The different positions of the button 22 are equivalent to different positions of the blade. The actual position is the most retracted one. If the user so desires, it is not necessary to push the button up to a locking position, but can stop anywhere in-between, if that is enough to thoroughly clean the tool or remove the tool. But if there is a resilient element forcing the rotary shaft and the tool back to the most retracted position, the user should hold the button 22 in that position until he is done.

Figure 5d shows an embodiment similar to the embodiment of Figure 5c, but with only one locking position.

It will be noted that any other kind of actuating and/or locking element known to the person skilled in the art may be utilized.

The present invention may be applied to any other food processor than a hand blender, for example a hand mixer 2 with blender arm 10, wherein the hand mixer 2 contains the motor part 6 for driving the blender arm 10.

Although having described several preferred embodiments of the invention, those skilled in the art will appreciate that various changes, alterations, and substitutions can be made without departing from the spirit and concepts of the present invention. The invention is, therefore, claimed in any of its forms or modifications with the proper scope of the appended claims. For example various combinations of the features of the following dependent claims could be made with the features of the independent claim without departing from the scope of the present invention. Furthermore, any reference numerals in the claims shall not be construed as limiting the scope.

## List of Reference Numerals:

	1	hand blender
	2	hand mixer
	6	motor part
	10	blender arm
5	11	connection
	12	tubular body
	13	rotary shaft
	14	cage
	15	blade
10	16	blade shaft
	21	push button
	22	button
	23	guidance
	24	ring
15	25	locking edge
	26	spring
	27	pneumatic resilient element
	30	safety switch
	31	mechanical switch
20	40	safety switch
	41	magnet
	42	magnetic switch
	50	safety switch
	51	light emitting diode
25	52	photo diode
	53	mark
	61	motor block connection
	62	housing
	63	switch

R	retracted position
P1, P2	protracted position
L1, L2	length

## CLAIMS:

1.           A blender arm having a tubular body equipped at one end with a connection for the connection with respect to a power unit, including an axially rotating shaft with a tool at the end opposite to the connection end, around which tool a peripheral protection is established, characterized in that the rotary shaft (13) with the tool (15) is attached movably  
5 in axial direction to the tubular body (12) so that the tool (15) may be positioned in a retracted position (R) or a protracted position (P1, P2).
2.           The blender arm according to claim 1, characterized in that the rotary shaft (13) is functionally connected to an actuating element (21, 22, 23, 24) designed as part of the  
10 tubular body (12) and moving the rotary shaft (13) in axial direction from the retracted position (R) to the protracted position (P1, P2) of the tool (15).
3.           The blender arm according to claim 1 or 2, characterized in that the rotary shaft (13) with the tool (15) is attached movably in axial direction to the tubular body (12) so  
15 that the tool (15) returns automatically from the protracted position (P1, P2) to the retracted position (R).
4.           The blender arm according to any one of claims 1 to 3, characterized in that it further comprises a resilient element (26, 27) functionally connected to the tubular body (12)  
20 and the rotary shaft (13) for moving the rotary shaft (13) from the protracted position (P1, P2) to the retracted position (R) of the tool (15).
5.           The blender arm according to any one of claims 1 to 4, characterized in that it further comprises a locking device (25) locking the tool (15) in protracted position (P1, P2).  
25
6.           The blender arm according to any one of claims 1 to 5, characterized in that the tool (15) is releasably attached to the rotary shaft (13), wherein release is possible in the protracted position (P1, P2).

7. The blender arm according to any one of claims 1 to 5, characterized in that the tool (15) is releasably attached to the rotary shaft (13), and may be positioned in a second protracted position (P2) for release.
- 5 8. A food processor (1, 2) with a power unit (6) and a blender arm (10) according to any one of claims 1 to 6 connected to the power unit (6).
9. The food processor according to claim 8, characterized in that it further comprises a safety switch device (30, 40, 50) for controlling the position of the tool and
- 10 allowing operation in case the tool (15) is positioned in retracted position (R).

1/9

10

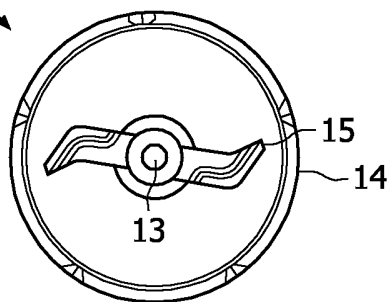

FIG. 1c

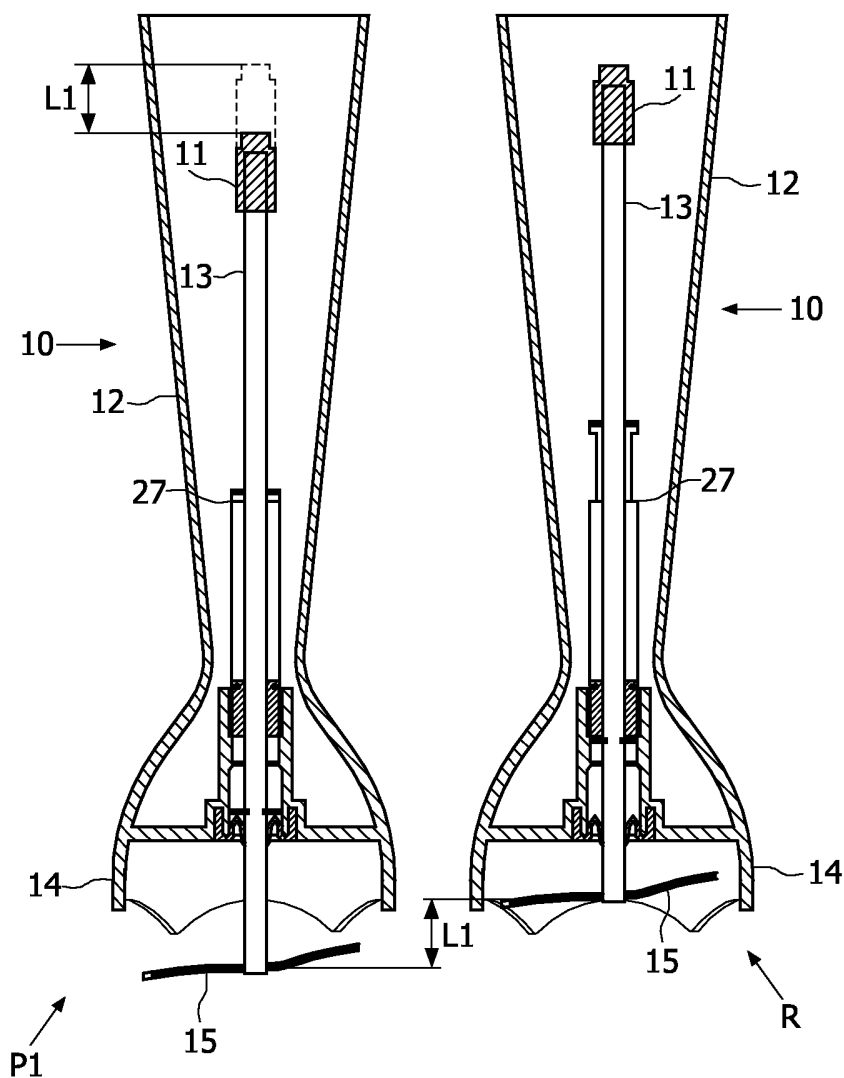

FIG. 1b

FIG. 1a

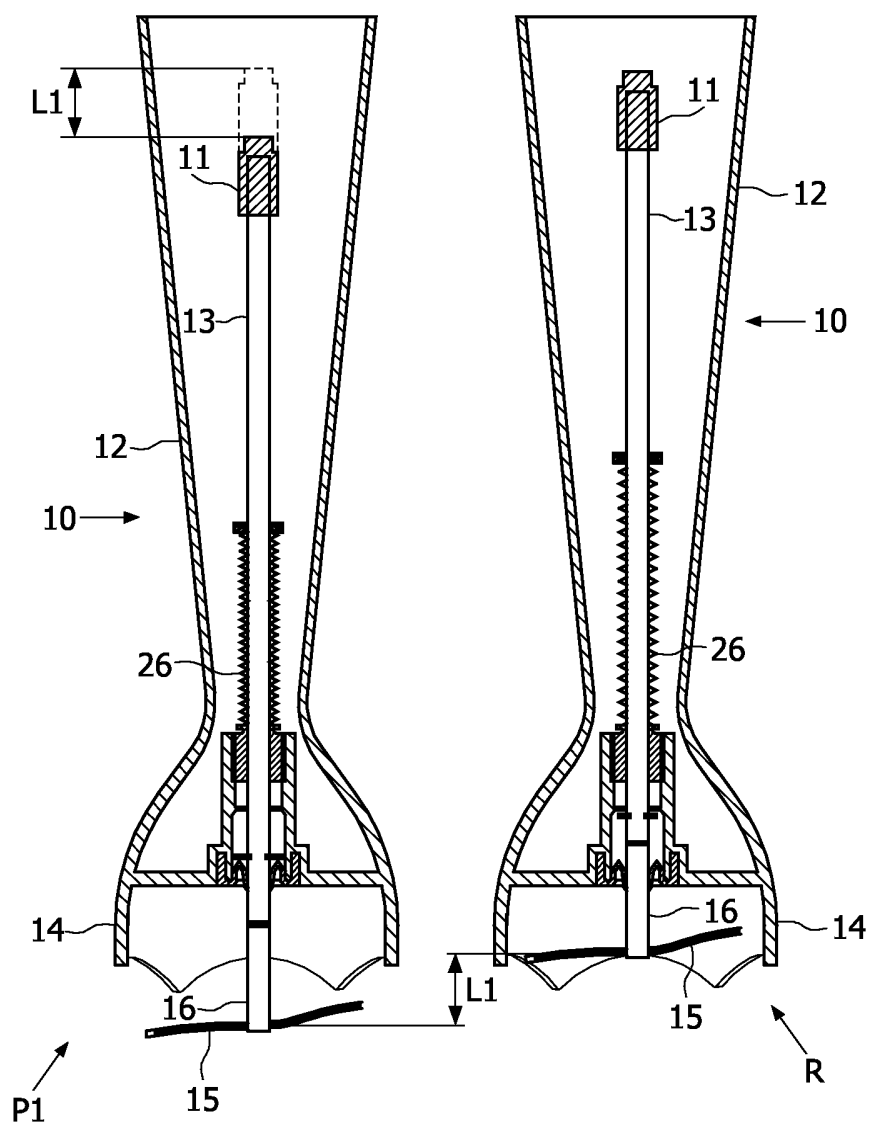

FIG. 2a

FIG. 2b

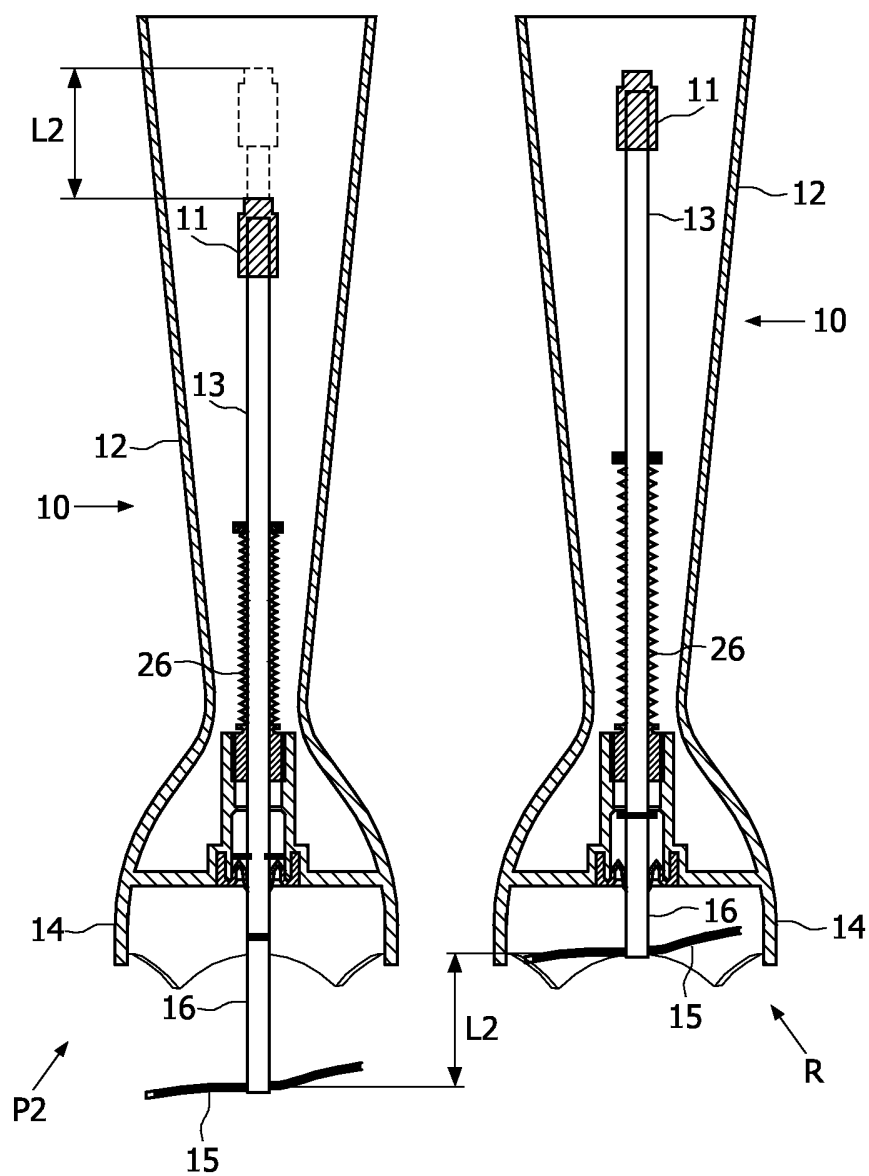

FIG. 3a

FIG. 3b

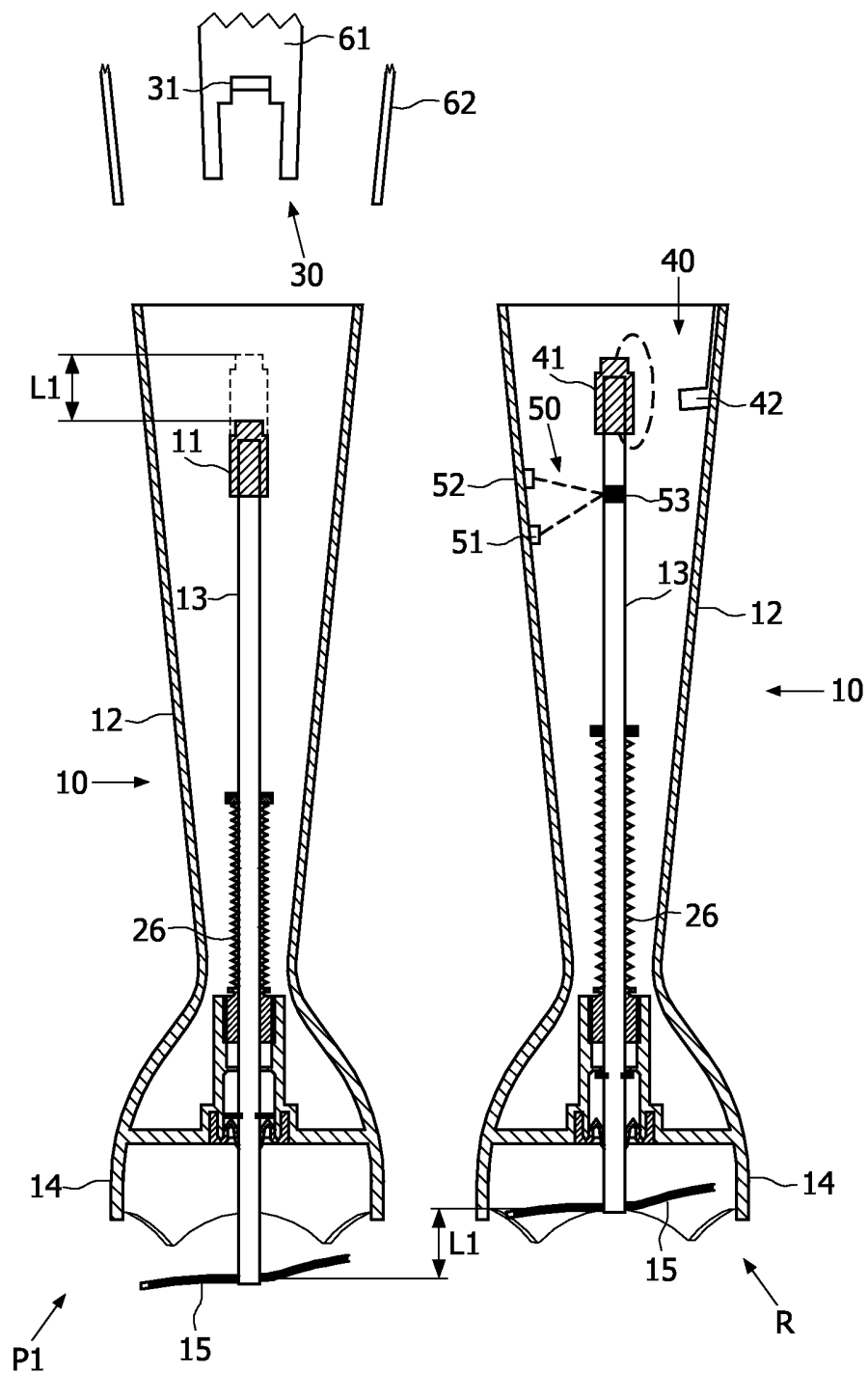

FIG. 4b

FIG. 4a

5/9

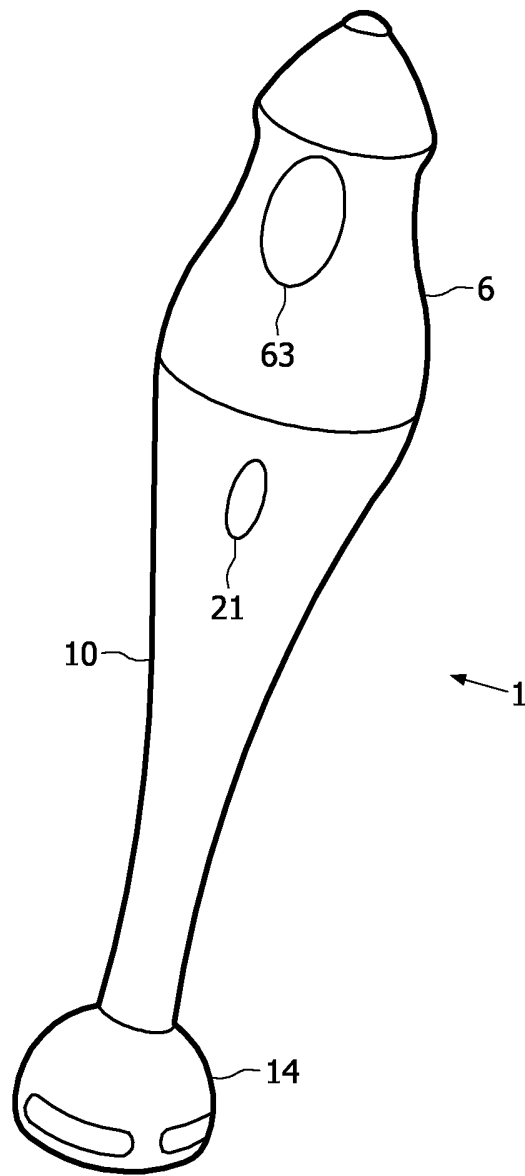

FIG. 5a

6/9

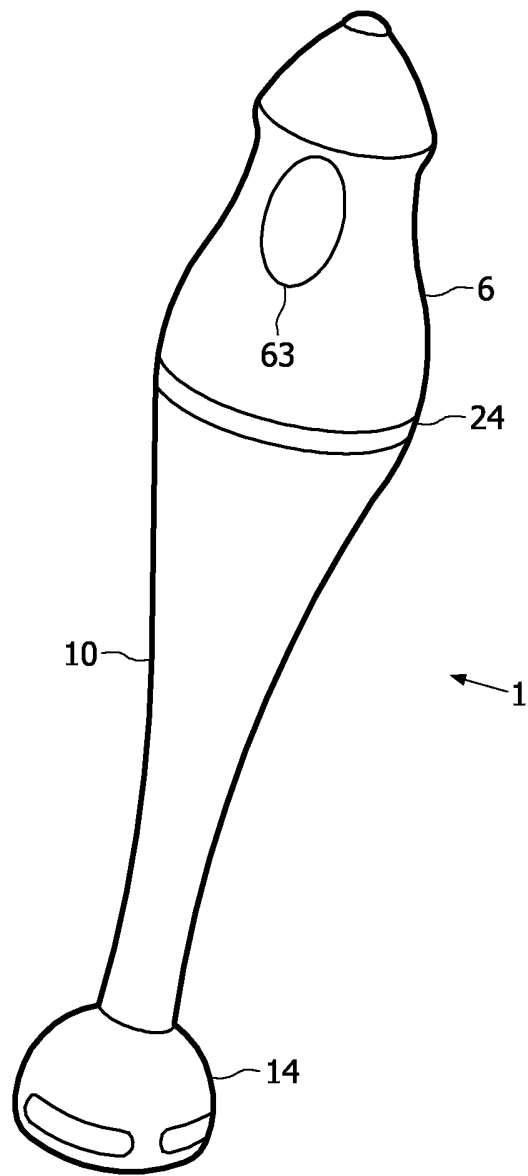

FIG. 5b

7/9

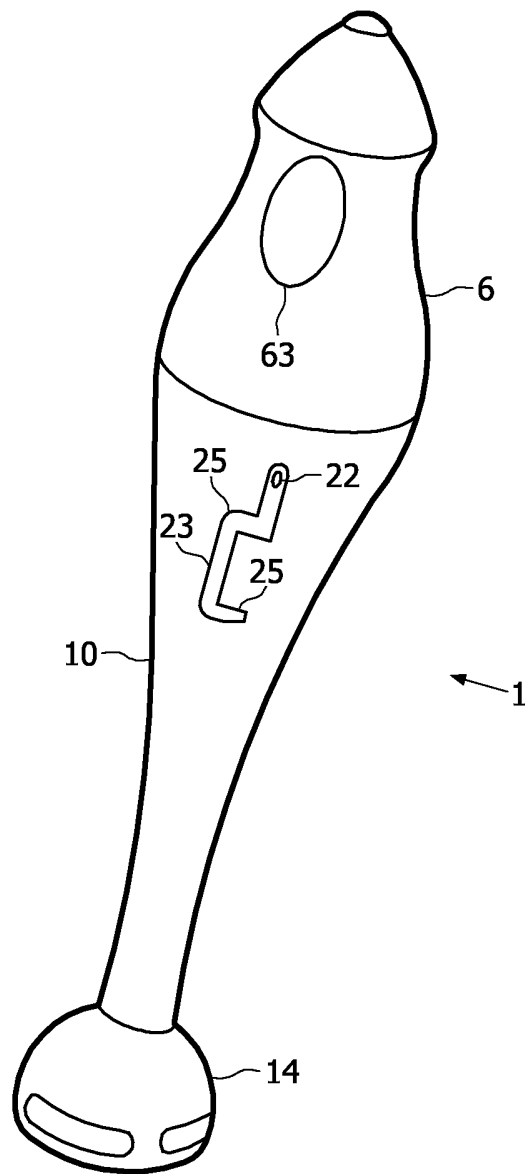

FIG. 5c

8/9

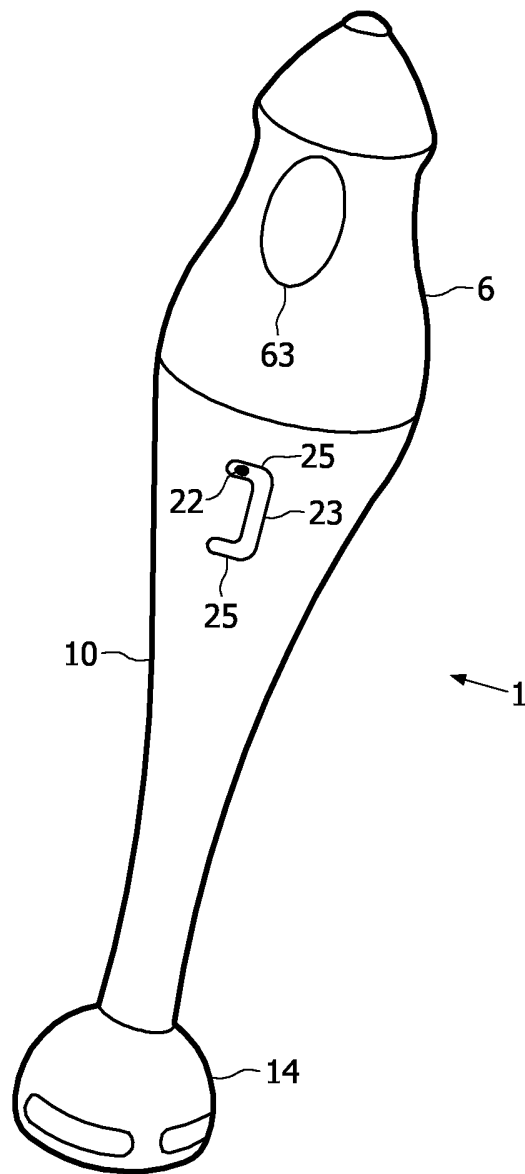

FIG. 5d

9/9

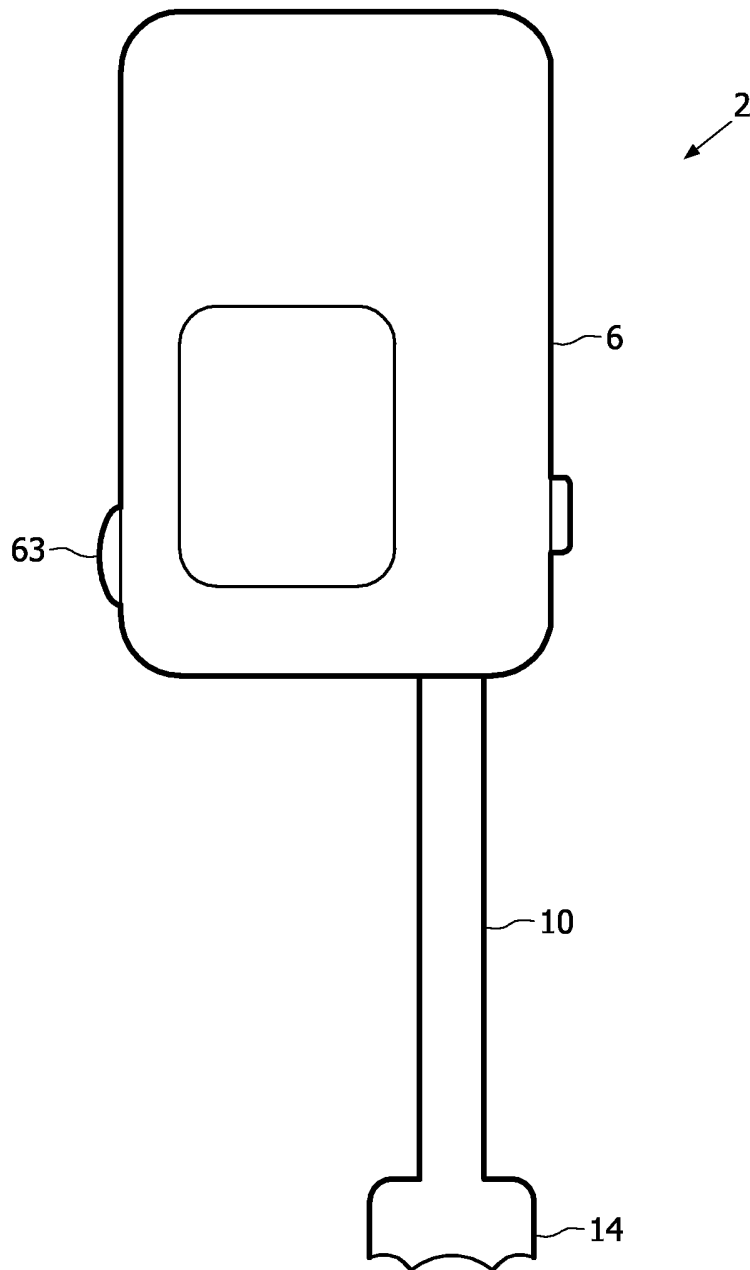

FIG. 6