



(86) Date de dépôt PCT/PCT Filing Date: 2003/01/22  
 (87) Date publication PCT/PCT Publication Date: 2003/07/31  
 (45) Date de délivrance/Issue Date: 2010/11/02  
 (85) Entrée phase nationale/National Entry: 2004/07/22  
 (86) N° demande PCT/PCT Application No.: NL 2003/000046  
 (87) N° publication PCT/PCT Publication No.: 2003/061802  
 (30) Priorité/Priority: 2002/01/25 (EP02075326.5)

(51) Cl.Int./Int.Cl. *B01D 3/00* (2006.01),  
*B01D 3/14* (2006.01)  
 (72) Inventeurs/Inventors:  
 DE GRAAUW, JOHANNES, NL;  
 STEENBAKKER, MAARTEN JAN, NL;  
 DE RIJKE, ARIE, NL;  
 OLUJIC, ZARKO, NL;  
 JANSSENS, PIETER JOHANNES, NL  
 (73) Propriétaire/Owner:  
 TECHNISCHE UNIVERSITEIT DELFT, NL  
 (74) Agent: BORDEN LADNER GERVAIS LLP

(54) Titre : COLONNE DE DISTILLATION A INTEGRATION DE CHALEUR  
 (54) Title: HEAT INTEGRATED DISTILLATION COLUMN

(57) **Abrégé/Abstract:**

The invention is directed to a heat integrated distillation column comprising a cylindrical shell having an upper and a lower end and at least one first inner volume and at least one second inner volume in the shell, and being in heat exchanging contact with each other through a wall separating the volumes, the improvement comprising providing means having heat exchanging capacity extending through the said wall from said at least one first volume into said at least one second volume, whereby the inside of the said heat exchanging means is in open connection with the said first volume.

## (12) INTERNATIONAL APPLICATION PUBLISHED UNDER THE PATENT COOPERATION TREATY (PCT)

(19) World Intellectual Property Organization  
International Bureau



(43) International Publication Date  
31 July 2003 (31.07.2003)

PCT

(10) International Publication Number  
**WO 03/061802 A1**

- (51) International Patent Classification<sup>7</sup>: **B01D 3/00**, 3/14
- (21) International Application Number: PCT/NL03/00046
- (22) International Filing Date: 22 January 2003 (22.01.2003)
- (25) Filing Language: English
- (26) Publication Language: English
- (30) Priority Data:  
02075326.5      25 January 2002 (25.01.2002)      EP
- (71) Applicant (for all designated States except US): **TECHNISCHE UNIVERSITEIT DELFT** [NL/NL]; Julianalaan 134, NL-2628 BL Delft (NL).
- (72) Inventors; and
- (75) Inventors/Applicants (for US only): **DE GRAAUW, Johannes** [NL/NL]; Meervalsloot 18, NL-2724 BK Zoetermeer (NL). **STEENBAKKER, Maarten, Jan** [NL/NL]; Willem Schürmannstraat 5 A, NL-3031 RM Rotterdam (NL). **DE RIJKE, Arie** [NL/NL]; Kortenaerstraat 4, NL-2676 VG Maasdijk (NL). **OLUJIC, Zarko** [NL/NL]; Nobellaan 56, NL-2641 XV Pijnacker (NL). **JANSENS, Pieter, Johannes** [NL/NL]; Planciusdreef 65, NL-2661 RK Bergschenhoek (NL).
- (74) Agent: **PRINS, A., W.**; Nieuwe Parklaan 97, NL-2587 BN Den Haag (NL).
- (81) Designated States (*national*): AE, AG, AL, AM, AT (utility model), AT, AU, AZ, BA, BB, BG, BR, BY, BZ, CA, CH, CN, CO, CR, CU, CZ (utility model), CZ, DE (utility model), DE, DK (utility model), DK, DM, DZ, EC, EE (utility model), EE, ES, FI (utility model), FI, GB, GD, GE, GH, GM, HR, HU, ID, IL, IN, IS, JP, KE, KG, KP, KR, KZ, LC, LK, LR, LS, LT, LU, LV, MA, MD, MG, MK, MN, MW, MX, MZ, NO, NZ, OM, PH, PL, PT, RO, RU, SC, SD, SE, SG, SK (utility model), SK, SL, TJ, TM, TN, TR, TT, TZ, UA, UG, US, UZ, VC, VN, YU, ZA, ZM, ZW.
- (84) Designated States (*regional*): ARIPO patent (GH, GM, KE, LS, MW, MZ, SD, SL, SZ, TZ, UG, ZM, ZW), Eurasian patent (AM, AZ, BY, KG, KZ, MD, RU, TJ, TM), European patent (AT, BE, BG, CH, CY, CZ, DE, DK, EE, ES, FI, FR, GB, GR, HU, IE, IT, LU, MC, NL, PT, SE, SI, SK, TR), OAPI patent (BF, BJ, CF, CG, CI, CM, GA, GN, GQ, GW, ML, MR, NE, SN, TD, TG).
- Published:**  
— with international search report
- For two-letter codes and other abbreviations, refer to the "Guidance Notes on Codes and Abbreviations" appearing at the beginning of each regular issue of the PCT Gazette.

(54) Title: HEAT INTEGRATED DISTILLATION COLUMN

(57) Abstract: The invention is directed to a heat integrated distillation column comprising a cylindrical shell having an upper and a lower end and at least one first inner volume and at least one second inner volume in the shell, and being in heat exchanging contact with each other through a wall separating the volumes, the improvement comprising providing means having heat exchanging capacity extending through the said wall from said at least one first volume into said at least one second volume, whereby the inside of the said heat exchanging means is in open connection with the said first volume.



**WO 03/061802 A1**

Title: Heat integrated distillation column

The invention relates to a heat integrated distillation column having separate volumes inside the column, which is especially suitable for distillation operations in the process industry. More in particular the invention relates to such a column, wherein the said volumes can be  
5 operated at different temperatures with improved heat exchange, thereby providing energy advantages in the operation.

It is well recognised that heat integration in distillation columns is an important means for providing improvements in energy efficiency in the operation of distillation. However, the application of this technology has  
10 been impeded by factors of cost of construction and the difficulty of providing adequate heat exchange, especially without complicated construction of the column(s).

In US-A 4,681,661 a heat integrated distillation column has been described, which column comprises a central column, and an outer, annular  
15 column around the central column. Thereby different regions are provided in the column, which regions can be operated at different pressures. Both regions are provided with conventional trays and downcomers.

In US-A 5,783,047 a heat integrated distillation column has been described, which column comprises an outer shell and inside one or more  
20 tubes. Thereby different regions are provided in the column, which regions can be operated at different pressures. However, in order to provide sufficient heat exchange area between the two regions in industrial large scale operations, several tubes of relatively small diameter have to be placed in the outer shell. Due to the relatively small diameter of the tubes, the use  
25 of distillation internals inside the tubes is limited to irregular packing rings or structured packing. The use of trays requires a complicated construction.

In US-A 4,234,391 a continuous distillation apparatus and method has been described, wherein a column has been divided into two

separate semi cylindrical sections by a dividing wall, one section functioning as stripping section and one as rectification section. It is an object of the present invention to provide a heat integrated distillation column, consisting of two separated volumes along the length of the column, wherein  
5 sufficient heat transfer is provided between the volumes. It is also an object of the invention to provide for a heat integrated distillation column of this type, wherein trays can be used.

This object and other objects are provided for by the column of the invention. This column is a heat integrated distillation column comprising a  
10 cylindrical shell having an upper and a lower end and at least one first inner volume and at least one second inner volume in the shell, being in heat exchanging contact with each other through a wall separating the volumes, the improvement comprising providing means having heat exchanging capacity extending through the said wall from said at least one  
15 first volume into said at least one second volume, whereby the inside of the said heat exchanging means is in open connection with the said first volume. Of course the heat exchange means have no connection for mass transfer to the other (second) volume.

The important aspect of the column of the present invention  
20 resides in the presence of means for providing heat exchange, which means extend into the other volume, thereby providing for the possibility of heat transfer from the one volume to the other volume, resulting in partial condensation of vapour in the hotter (usually high pressure) section and (partial) evaporation of liquid in the cooler (usually low pressure) section.

25 The heat integrated distillation column of the invention preferably has an enriching section and a stripping section, one of the volumes being the enriching section and the other being the stripping section. When the terms 'enriching section' and 'stripping section' are used herein they are also to be considered referring to the separate volumes of  
30 the column.

The heat integrated distillation column of the invention has a construction in which the enriching (rectification) section (E) (portion above the feed stage) and the stripping section (S) (portion below the feed stage), as encountered in a conventional distillation column are separated from each other and disposed in parallel, and the operating pressure of the enriching section is made higher than that of the stripping section so that the operating temperature of the enriching section becomes higher than that of the stripping section. In this configuration, if there exists a heat transfer surface between them, heat transfer occurs from the enriching section to the stripping section. In the heat integrated distillation column of the invention the heat transfer occurs from the enriching section to the stripping section.

The invention can be seen in two preferred embodiments. In the first embodiment the heat exchange means are located in the cooler section and vapour is introduced into the heat exchange means from the hotter section and condenses in the heat exchange means, thereby giving off heat to the cooler section. The condensed vapour (liquid) is returned to the hotter section. On the outside of said heat exchange means, liquid is evaporated.

In the second embodiment the heat exchange means are located in the hotter section and liquid from the cooler section is passed into the heat exchange means. Said liquid is (partially) evaporated inside the heat exchange means and vapour (partially) condenses on the outside of the said heat exchange means. The vapour generated in the heat exchange means is returned to the cooler section. In general it is preferred to have liquid film flow in both embodiments.

In the heat integrated distillation column of the invention, in both of the volumes, vapour which enters from the lower end and goes out of the upper end comes in contact with liquid which enters from the upper end and flows to the lower end, on the surface of the packing or on the trays. At this time, the mass transfer occurs, and hence the distillation operation is performed. In the heat integrated distillation column of the invention, two

distillation sections, i.e., a higher-pressure section and a lower-pressure section are disposed in one column.

In contrast to the conventional distillation column in which the heat input is provided by a reboiler, according to the heat integrated  
5 distillation column of the invention, the heat input is mainly provided in the whole of the stripping section, with the result that the heat load on the reboiler can be minimised. In the conventional distillation column, the heat removal is performed by a condenser disposed at the top of the column. In  
10 contrast, according to the heat integrated distillation column of the invention, the heat removal is performed in the whole of the enriching section with the result that the condenser duty can be minimised. Accordingly, it is possible to save a considerable amount of energy, compared with conventional distillation columns.

In a heat integrated distillation column, vapour is condensed in  
15 the enriching section, and hence the flow rate of the vapour is decreased toward the upper portion and liquid is vaporised in the stripping section, so that the flow rate of the vapour is increased toward the upper portion. Therefore, in order to ensure that the ratio of the volume flow rate of the ascending vapour and the cross-sectional area of the specific volume is kept  
20 within the operating range of column internals irrespective of the height of the column, the volume cross-sectional area should be decreased when moving from the bottom to the top of the enriching section, and increased when moving from the bottom to the top of the stripping section. This aspect of a preferred embodiment of the invention has been shown in the figures,  
25 which will be discussed below.

The column of the invention may be constructed in various ways, provided the two volumes are always adjacent to each other, divided by a separating wall. In practice this means that two possibilities are preferred. The first possibility is a column, having a concentric inner column. The

other possibility is a column provided with a dividing wall that reaches from one side of the column to the other side.

The column of invention contains means for improving vapour/liquid contact, which means can for example be trays, which is preferred, but also random or structured packings. It is not necessary to have the same system of said means for improving vapour/liquid contact in both volumes.

As indicated above, preference is given to the use of trays with downcomers, as these provide an easy and uncomplicated way of providing vapour/liquid contact. In this embodiment the means for heat exchange, preferably vertical heat transfer panels, are provided in the downcomer, and the liquid that flows down is distributed over the surface of the panels by means of liquid distribution systems.

The means having heat exchanging capacity can have the form of plates or a tubular construction. The surface of the plates or tubes can be smooth or textured. In general it is possible to use coils, flat plates, dimple plates, finned plates or finned tubes, corrugated plates or other plates that enhance heat transfer.

In general it is preferred that there are vapour-liquid disengagement means present in, in between, around or above the heat exchange means, to improve separation of vapour from liquid. Suitable means are fins, vanes, corrugated structured packing sheet, dumped packing and the like.

The heat exchange means extend through the wall from the first volume into second volume, whereby the inside of the said heat exchanging means is in open connection with the said first volume.

In a first embodiment of the invention, the heat exchange means are in open connection with the section having the highest temperature (the enriching section) and vapour enters the heat exchange means from the enriching section and condenses inside. The heat is transferred through the

walls into the second volume (the stripping section), where liquid evaporates on the outside surface of the heat exchange means. The condensate flows back into the enriching section.

In the second embodiment, the heat exchange means are in open  
5 connection with the section having the lowest temperature (usually the stripping section) and liquid enters the heat exchange means from said volume and is partially vapourised on the inner surface of the heat exchange means by heat transferred through the wall of the heat exchange means from the section having the highest temperature (the enriching section). In  
10 this section vapour condenses on the outside surface of the heat exchange means. The remaining liquid flows back into the stripping section, as well as the vapour,.

The present invention is especially suitable for use in energy intensive distillation operations. Examples thereof are liquid air distillation  
15 and the various separations in the petrochemical industry, such as ethane/ethylene separation, propane/propylene separation, butane/isobutane separation, air separation, distillation to break azeotropes and the like.

An important aspect in the invention is the difference in operating  
20 pressure between the two volumes. In order to obtain such difference means have to be present to increase the pressure of the vapour stream going from one volume to the other volume (such as a blower or a compressor). The pressure in the enriching (or rectification) section will be higher than the pressure in the stripping section. In general the ratio of the pressures will  
25 not be much higher than that required theoretically to obtain sufficient amount of vaporisation of the liquid in the stripping section. In general this ratio will not exceed 2.

The invention will now be elucidated on the basis of a number of figures, wherein preferred embodiments of the invention will be described.  
30 These figures are not intended as limiting the scope of the invention.

### Description of Figures

Figure 1 shows a top view of a tray in a concentric column  
5 according to an embodiment of the invention, which column has been fitted  
with trays and downcomers,

Figure 2 shows a vertical cross-section of the column depicted in  
Figure 1, along the line A-A,

Figure 3 shows a top view of a tray below that depicted in Figure  
10 1,

Figure 4 shows a vertical cross-section along the line B-B in Fig 3,

Figure 5 shows a possible configuration of the liquid distribution  
system in a three-dimensional drawing,

Figures 6 a-b-c-d show a possible assembly of heat transfer  
15 panels,

Figure 7 shows a top view of a column of the invention based on a  
flat wall dividing the column into two volumes,

Figure 8 shows a cross section of the divided wall column,

Figures 9 and 10 show the feature that the ratio of the cross  
20 sectional areas of stripping and enriching sections varies with the volume of  
vapour along the height of the column.

Figure 11 shows a vertical cross-section of a column according to a  
further embodiment of the invention,

Figure 12 shows various cross-sections of heat exchange means  
25 suitable for use in the embodiment of figure 11, and

Figure 13 shows an enlarged cross-section of heat exchange  
means of figure 12.

### Detailed description of Figures

Figure 1 shows a top view of a tray and Figure 2 a vertical cross section of a part of the column according to an embodiment of the invention, wherein the heat exchange means are in open connection with the volume of the highest temperature. The cross section shows 4 trays (a, b, c, d) in the inner column and 4 trays in the annular outer column. The top view refers to tray (a) as indicated in the cross section. The trays can be either sieve trays or any other type used in industrial distillation such as valve trays, bubble cap trays, or tunnel trays. The dashed lines on the top view drawing show the downcomers positioned above the tray.

Tray (a) of the inner column is of ordinary cross flow design and provided with rectangular downcomer pipes. The arrows indicate the direction of the liquid flowing over the tray. The liquid exiting the downcomers from the tray above enters tray (a) on the right-hand side, flows over the tray and is then collected in the downcomers on the left-hand side.

In this example the trays in the outer annular column are provided with four downcomers in which the heat transfer panels are mounted. The liquid exiting a downcomer from the tray located above tray (a) splits up at the outlet into two equal portions each entering the active area of tray (a). The arrows indicate the direction of the liquid flow over the tray. At the end of the active area section the liquid is collected in main troughs, which are positioned above the downcomers. These troughs are provided with side channels that enable the distribution of the liquid over the heat transfer panels.

The cross section drawing at location A-A shows the position of the trays and the heat transfer panels. The top of the heat transfer panels is connected via one or more tubes to the vapour space of the inner column. At

the bottom the heat transfer panels are provided with a tube for drainage of the condensate to the tray of the inner column.

Figure 3 shows a top view of tray (b) that is located direct below tray (a) and Figure 4 the cross section B-B. The position of the downcomers in the outer column has been rotated over an angle of 45° with respect to the tray above. In case the trays of the annular column are provided with 2 downcomers this rotation angle will be 90° and in case of 6 downcomers 30°.

Figure 5 shows a three-dimensional drawing of a possible configuration of the liquid distribution system placed above the heat transfer panels in the downcomers of the stripping section. The liquid flows via the main troughs into the side channels. In the walls of the side channels holes are provided to distribute the liquid over the heat transfer panels. At the outside of channel walls the holes are covered with splash plates to ensure a film flow of liquid over the heat transfer panels. For this reason the splash plates extend over the top of the heat transfer panels. At the end of the channels weirs are provided to maintain a constant liquid level. Excessive liquid is discharged over these weirs.

In Figures 6 a-b-c-d a possible assembly of heat transfer panels is shown. In this example the assembly consists of 6 parallel panels. The panels are preferably constructed of corrugated sheets oriented in vertical direction. Other constructions like coils, flat plates, dimple plates, finned plates or other plates that enhance heat transfer are possible too. The Figure 6d shows that by the corrugations vertical channels are obtained. At the top these channels are connected to a vapour inlet channel. The six vapour inlet channels are connected to a header with two vapour inlets. In a similar way the condensate is drained into the inner column at the bottom of the panels via liquid outlet channels connected to a liquid collection header.

Figure 7 shows a top view and Figure 8 shows a cross section of a column of the invention based on a wall dividing the two volumes. In these figures the same features are shown as in the Figures 1-4.

Figures 9-10 show the feature that ratio of the cross sectional areas of stripping and enriching sections varies with the amount of vapour along the height of the column. This has been shown for two possible constructions. In Figure 9 a single cylindrical shell column separated by a divider into two semi cylindrical volumes is shown. The cross sectional area of both enriching and stripping section is changed stepwise. Figure 10 shows the stepwise cross sectional area variation for a concentric column.

Figure 11 shows a vertical cross-section of a column according to a second embodiment of the invention, wherein the heat exchange means are located in the central (enriching) section and are in open connection with the annular (stripping) section. As can be seen in the figure, liquid enters the tubular means from a tray and flows down, preferably as a film, inside the tube. Part of the liquid evaporates inside the means and rises. The vapour flows from the top of the heat exchange means into the annular section, whereby said means preferably have liquid-gas disengagement means to provide a proper gas-liquid separation. The remaining liquid that is not evaporated flows back into the stripping section from the bottom of the heat exchange means.

Figures 12 and 13 shows various cross-sections of an example of a suitable heat exchange means for the embodiment described in relation to figure 11. In the figures (a), (b) and (c) indicate the various connections of the heat exchange means with the annular section. (a) is the connection through which the unvaporised liquid flows back into the annular section, (b) is the liquid entry and (c) is the vapour removal connection. (d) is a possible form of vapour-liquid disengagement means.

**Example**

A column in accordance with the construction of Figures 1-5, having panels in the downcomers and the constructional details in Table 1 is used for distillation of the system propane/propylene. The overall heat transfer coefficient is 700 W/m<sup>2</sup>K and the heat transfer area per tray is 10.5 m<sup>2</sup>.

Table 1

10

Diameter outer column	2.5 m
Diameter inner column	1.2 m
Tray spacing	0.5 m
Length heat exchange panels	0.55 m
15 Height panels	0.4 m
Heat transfer area per panel	0.44 m <sup>2</sup>
Number of panels per tray	24
Number of panels per downcomer	6

20

For the same type of column as above, but using tubes as heat exchange device, the corresponding dimensions are as follows.

Table 2

25

Length tubes (hairpins)	0.5 m
Diameter tubes (external)	20 mm
Pitch (rectangular)	30 mm
Tubes per downcomer	84

30

**CLAIMS:**

1. Heat integrated distillation column comprising a cylindrical outer shell having an upper and a lower end and at least one first inner volume and at least one second inner volume in the shell, and being in heat exchanging contact with each other through a wall separating the volumes, the improvement comprising providing means having heat exchanging capacity extending through the said wall from said at least one first volume into said at least one second volume, whereby the inside of the said heat exchanging means is in open fluid connection with the said first volume.
2. Column according to claim 1, wherein the said column is provided with an inner tube which is concentric with the outer shell, thereby defining a volume inside the inner tube and an annular volume between inner tube and outer shell.
3. Column according to claim 1, wherein the said first and said second volume have been created by a separating wall extending along the inside of the outer shell, and connected at both ends to the outer wall.
4. Column according to any one of claims 1 to 3, wherein said first volume is constructed to act as stripping section and said second volume as enriching section.
5. Column according to any one of claims 1 to 4, wherein the heat exchange means are present in the volume that has been designed as the volume with the highest temperature and is in open connection with the volume designed to have the lowest temperature.
6. Column according to any one of claims 1 to 4, wherein the heat exchange means are present in the volume that has been designed as the volume with the lowest temperature and is in open connection with the volume designed to have the highest temperature.

7. Column according to any one of claims 1 to 6, wherein vapour disengagement means is present.
8. Column according to claim 7, wherein said vapour disengagement means comprises fins, vanes, a corrugated structured packing sheet or dumped packing rings.
9. Column according to any one of claims 1 to 8, wherein the both volumes are provided with trays and downcomers.
10. Column according to any one of claims 1 to 7, additionally comprising an enriching section provided with trays and downcomers and a stripping section provided with structured or random packing.
11. Column according to any one of claims 1 to 7, additionally comprising a stripping section provided with trays and downcomers and an enriching section provided with structured or random packing.
12. Column according to any one of claims 1 to 7, additionally comprising a stripping section and an enriching section both provided with a structured or a random packing.
13. Column according to any one of claims 1 to 12, wherein said means providing heat exchanging capacity comprises a panel or a tubular construction.
14. Column according to claim 13, wherein said means providing heat exchanging capacity comprises corrugated sheets oriented in vertical direction, coils, flat plates, dimple plates or tubes, finned plates or finned tubes or plates or tubes that enhance heat transfer.
15. Column according to any one of claims 1 to 14, wherein a plurality of said means having heat exchanging capacity is present along the length of the column.

16. Column according to any one of claims 1 to 15, wherein the said means having heat exchanging capacity is located in a downcomer of a tray.
17. Column according to any one of claims 9 to 11, wherein the heat exchange means is located between the trays.
18. Column according to any one of claims 1 to 17, wherein the volume of one section increases from the lower end to the upper end and the volume of the other section simultaneously decreases from the lower end to the upper end.
19. Column according to any one of claims 1 to 18, wherein means are present for providing a pressure difference between the said first volume and the said second volume.
20. A method for distillation, the method comprising:
  - providing a heat integration distillation column having an outer shell with a first and a second volume in heat exchanging contact with one another through a dividing wall;
  - providing at least one heat exchanger to further exchange heat between the first and second volumes wherein the heat exchanger is fluidly connected with one of the first or the second volumes;
  - providing a plurality of trays with downcomers positioned within the first inner volume, the second inner volume, or both the first inner and the second inner volume wherein the heat exchanger is positioned either at the downcomer of one of the plurality of trays or between the plurality of trays; and
  - moving contents through the heat exchanger to facilitate further heat transfer from the fluidly connected first or second volume to the other volume without transferring mass between the first volume and the second volume.
21. Use of a column according to any one of claims 1 to 19, for distillation.

1/10

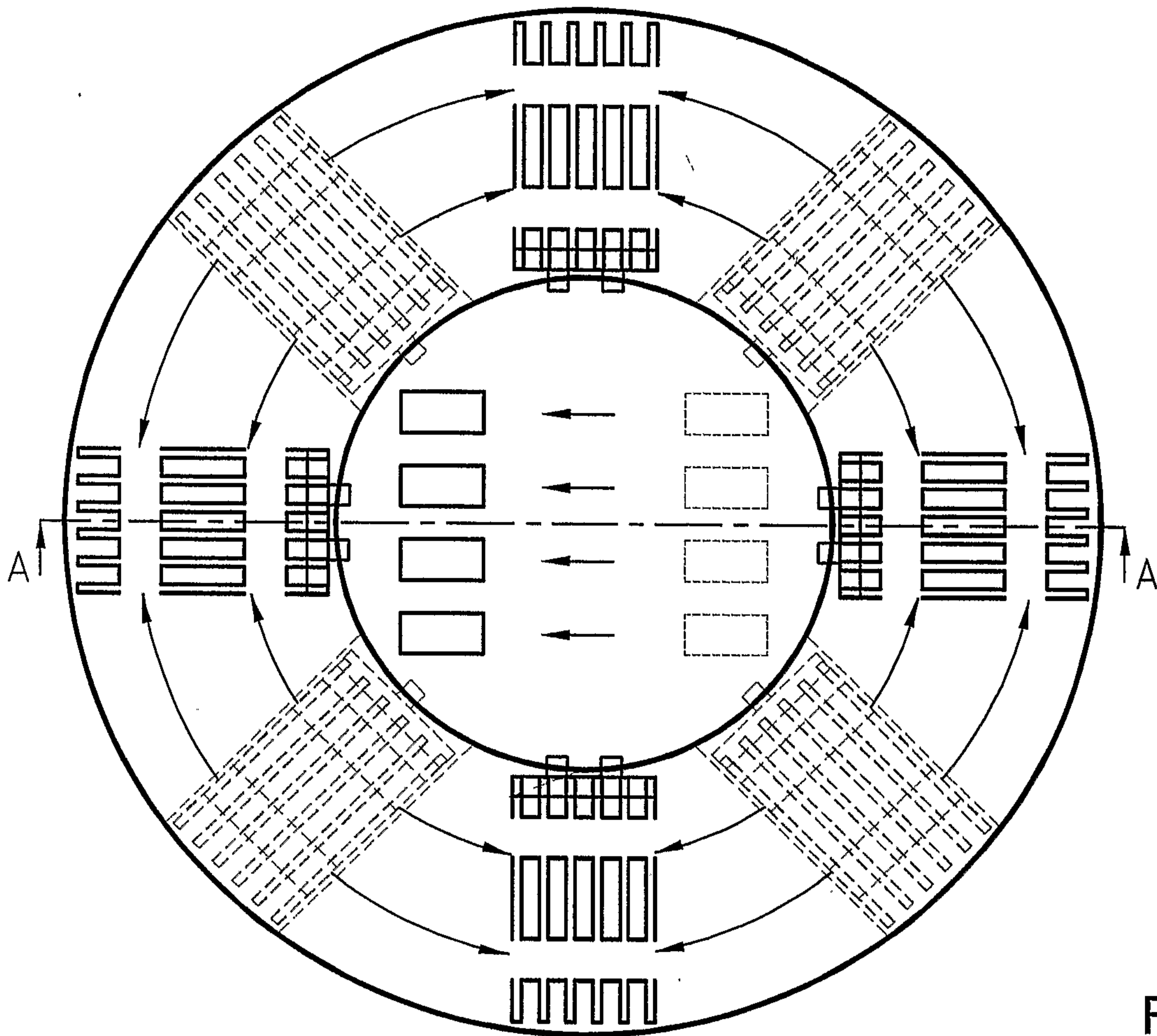

Fig. 1

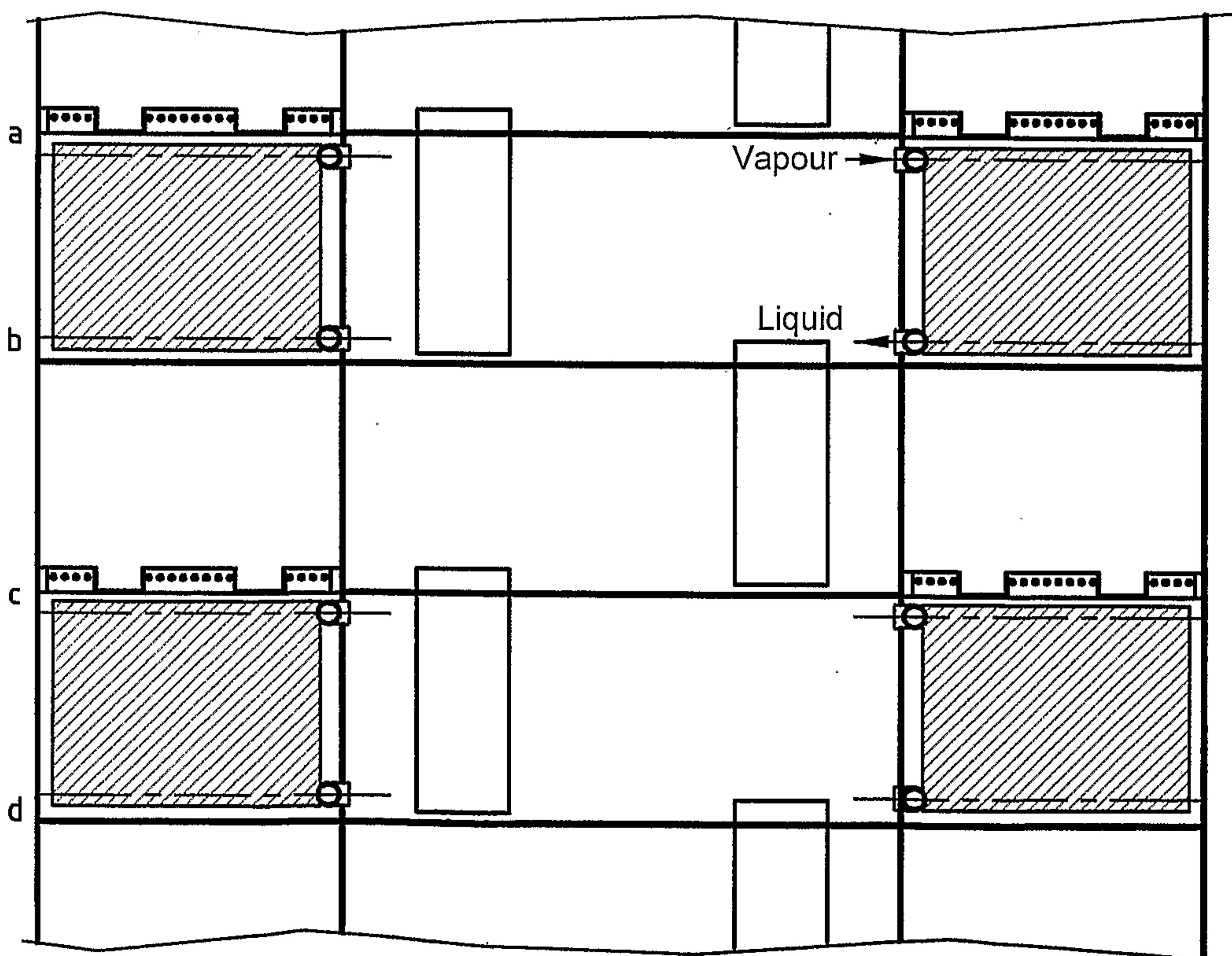

Fig. 2

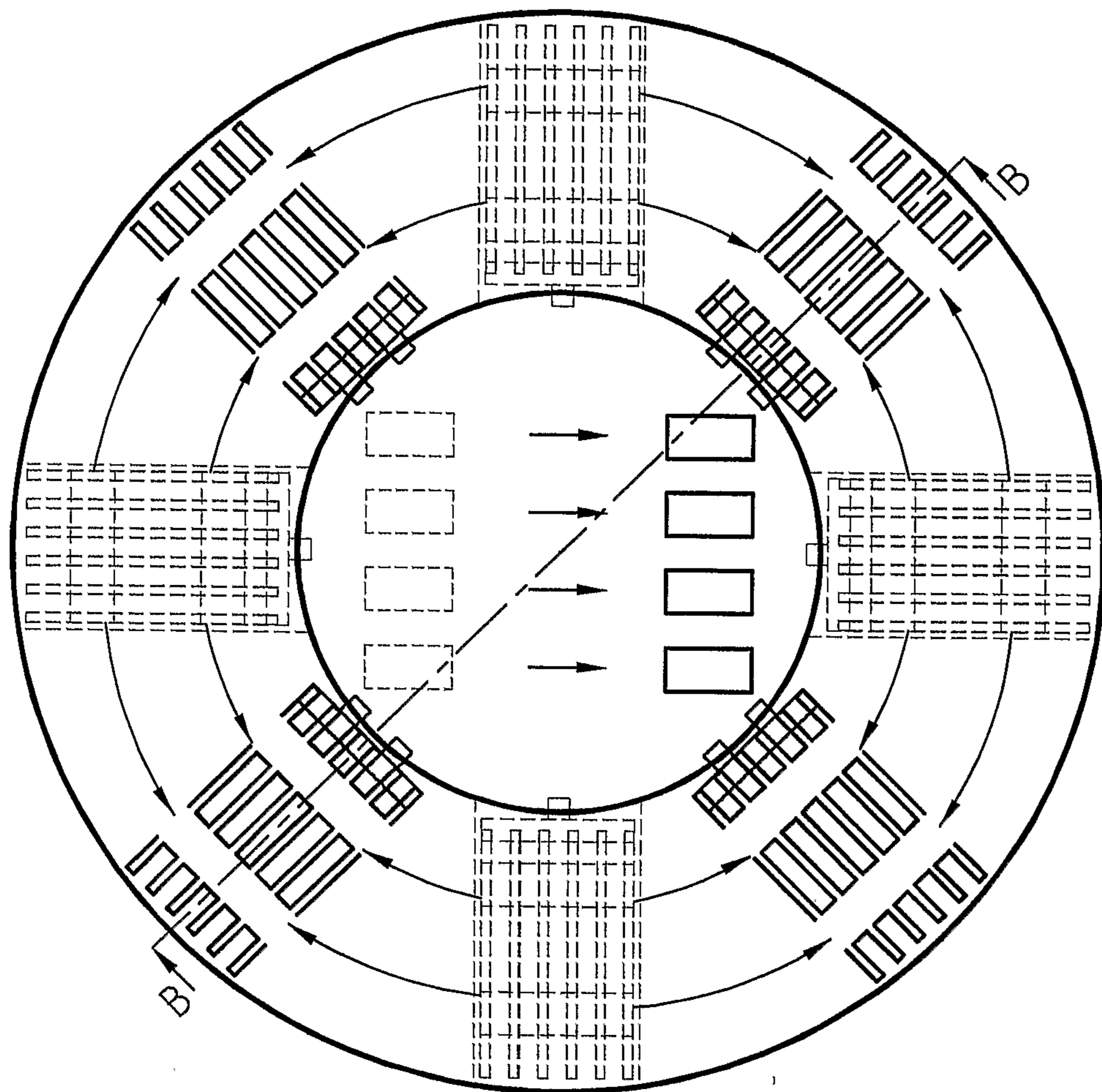

Fig. 3

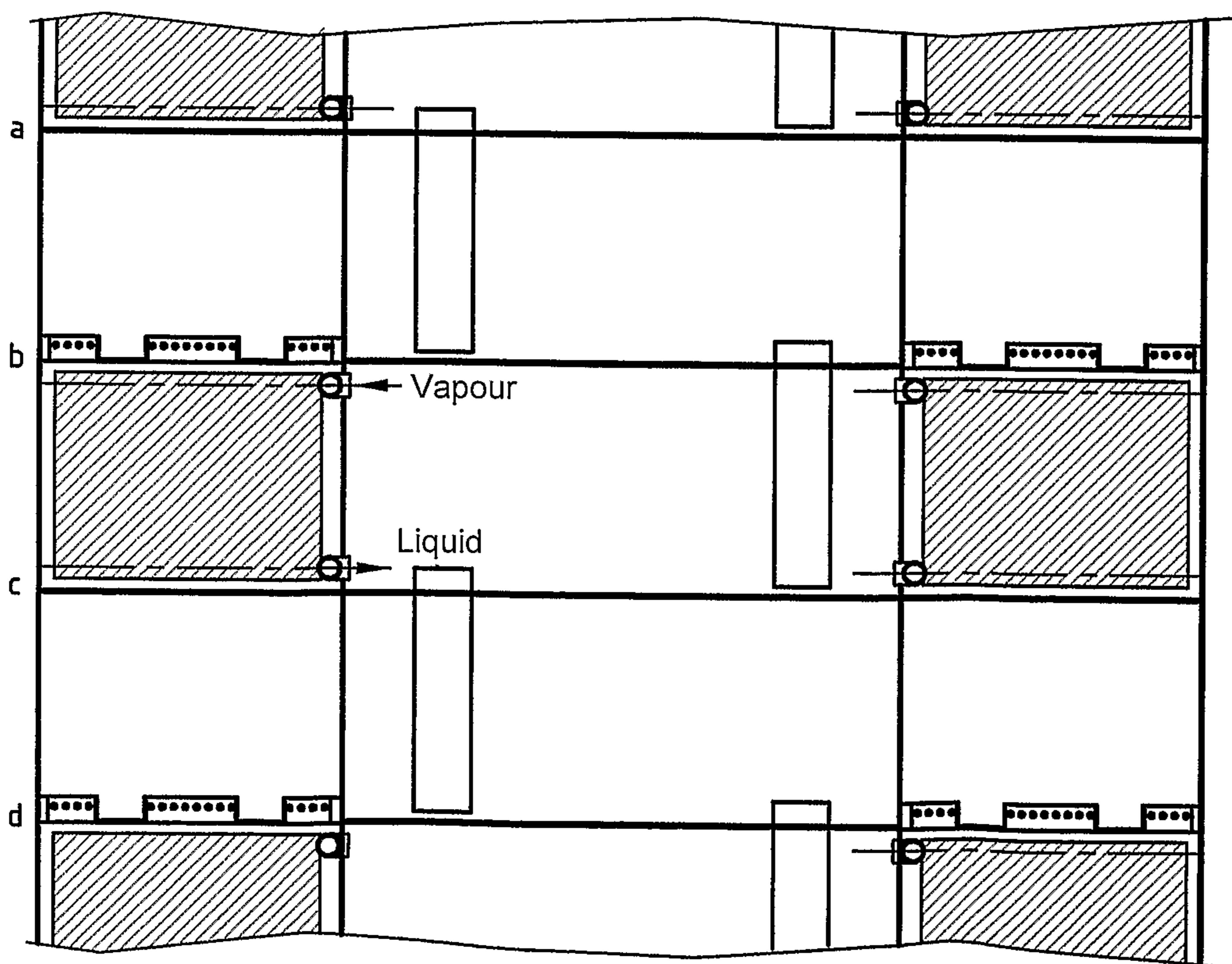

Fig. 4

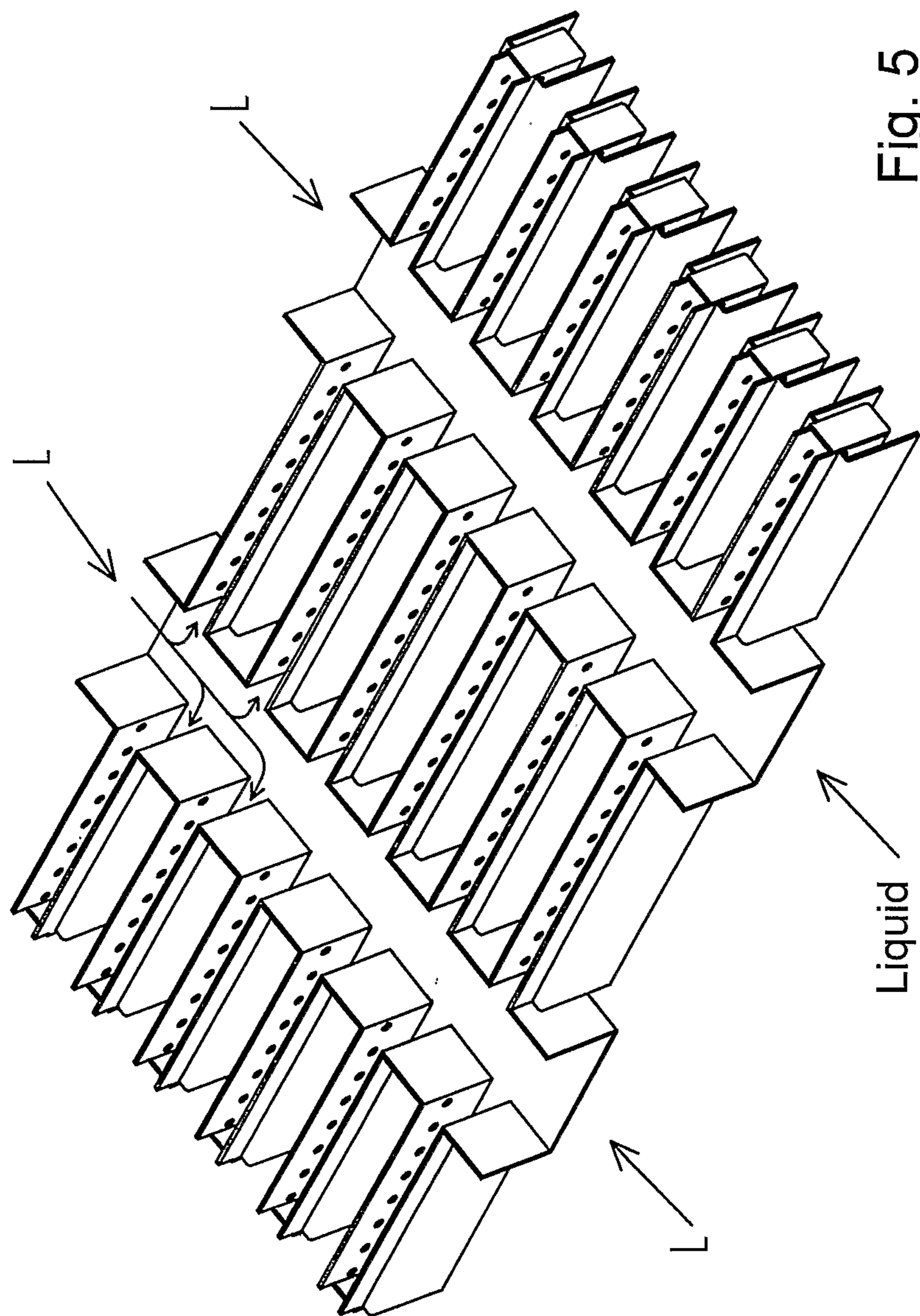

Fig. 5

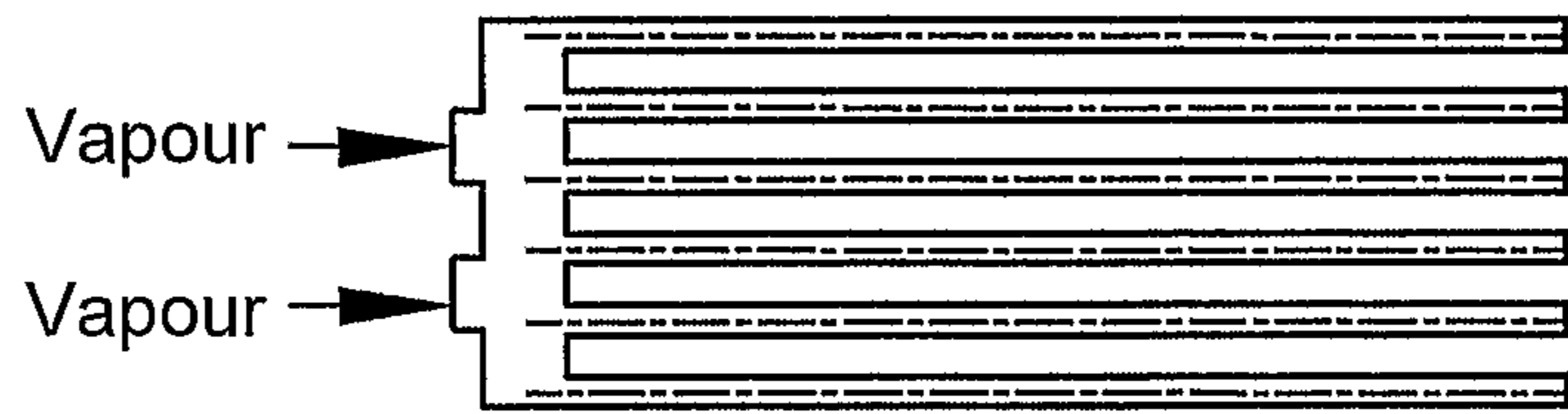

Fig. 6a

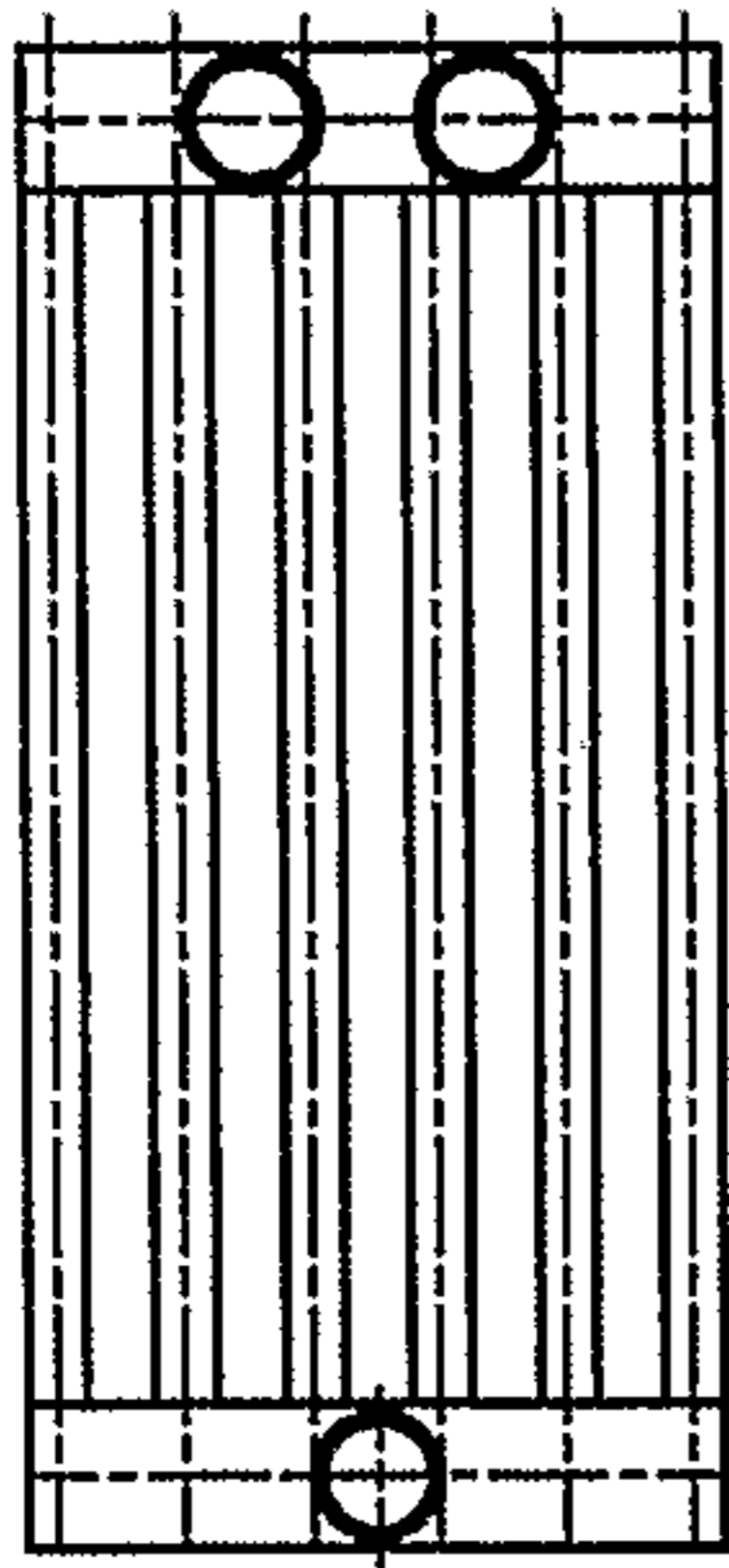

Fig. 6b

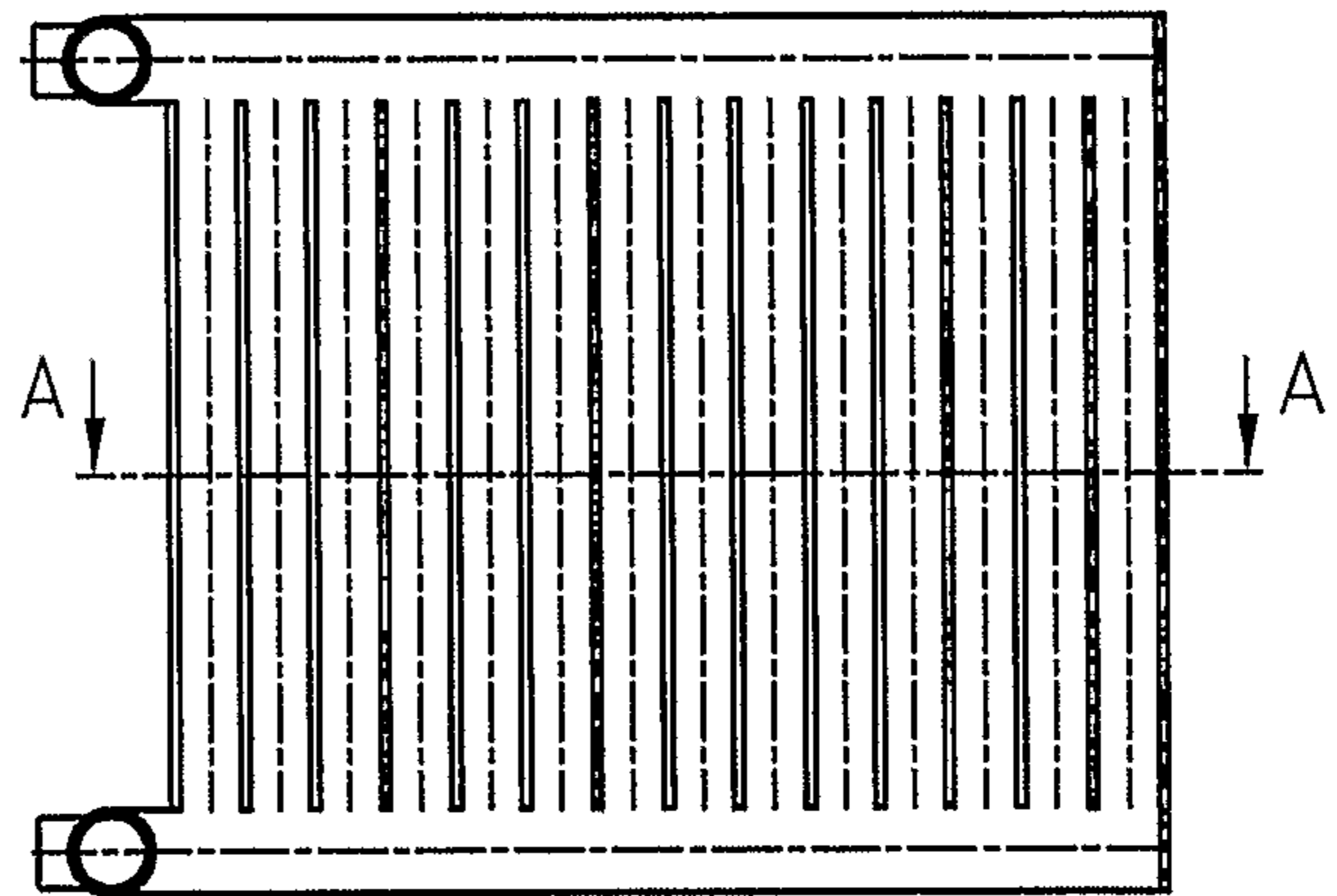

Fig. 6c

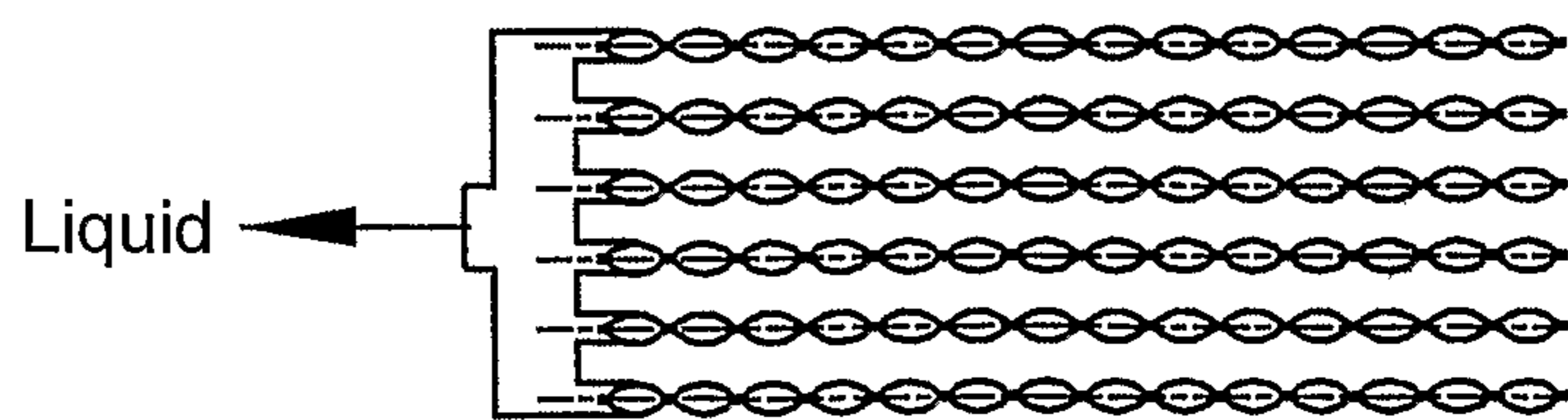

Fig. 6d

5/10

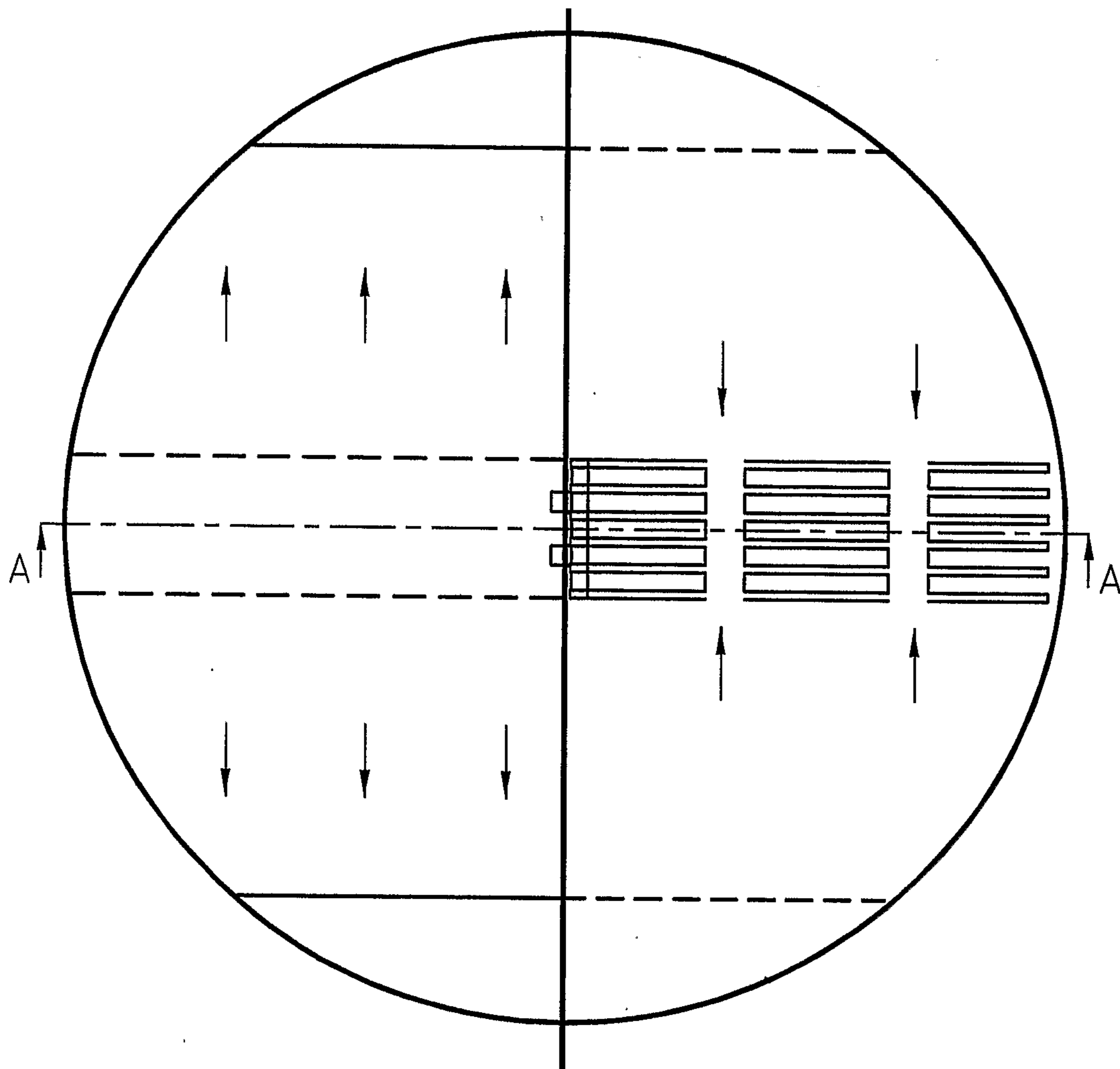

Fig. 7

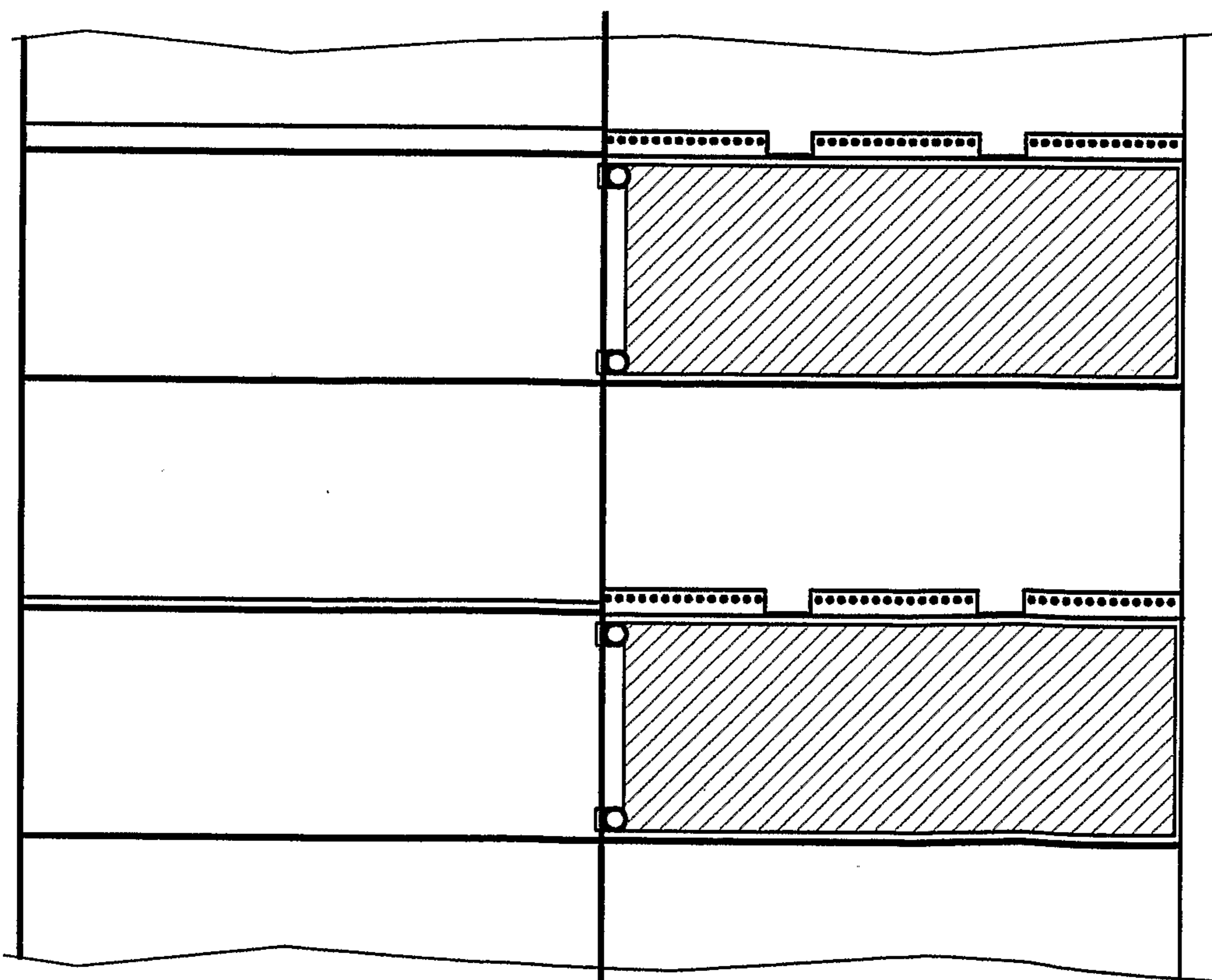

Fig. 8

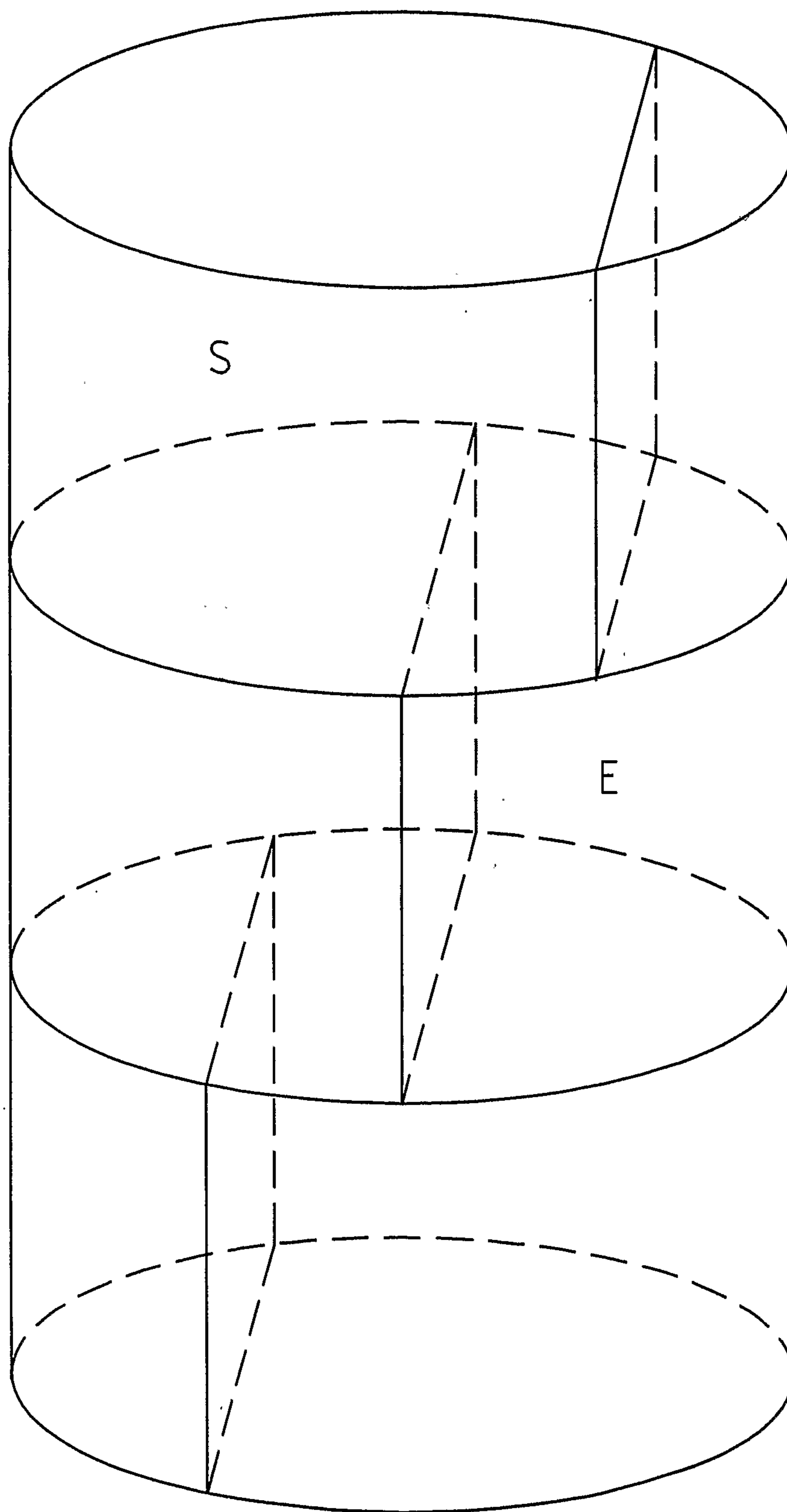

Fig. 9

7/10

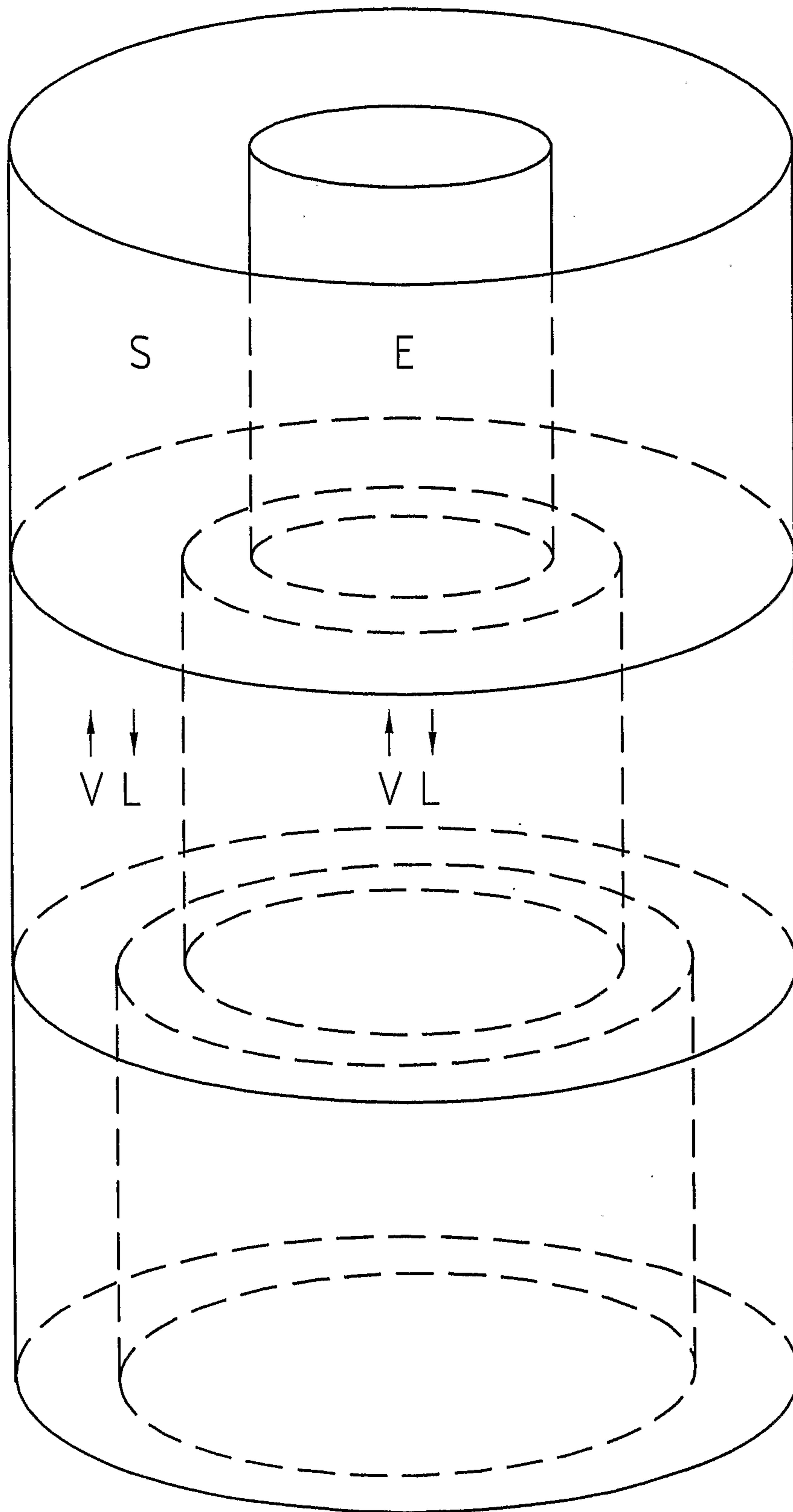

Fig. 10

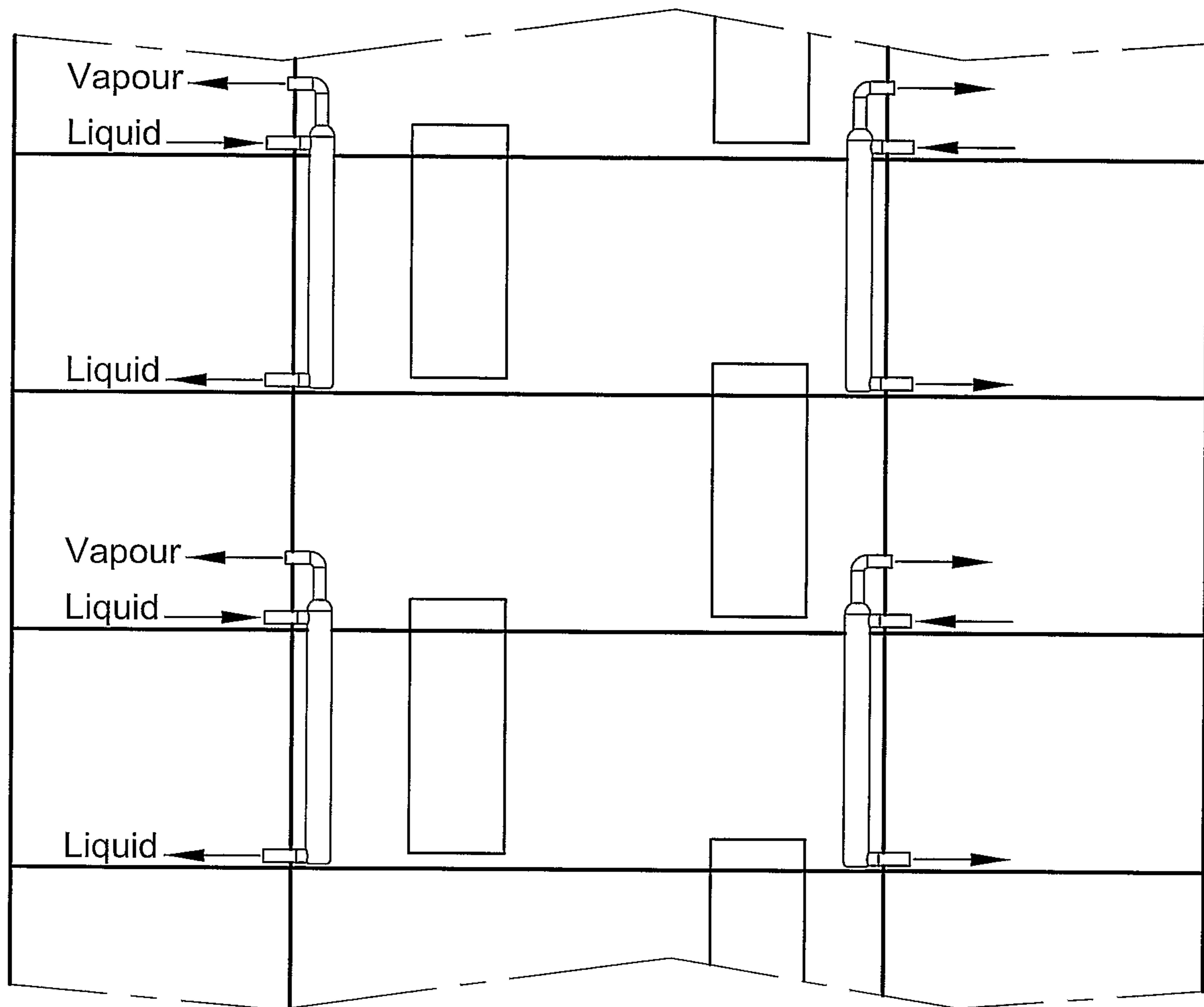

Fig. 11

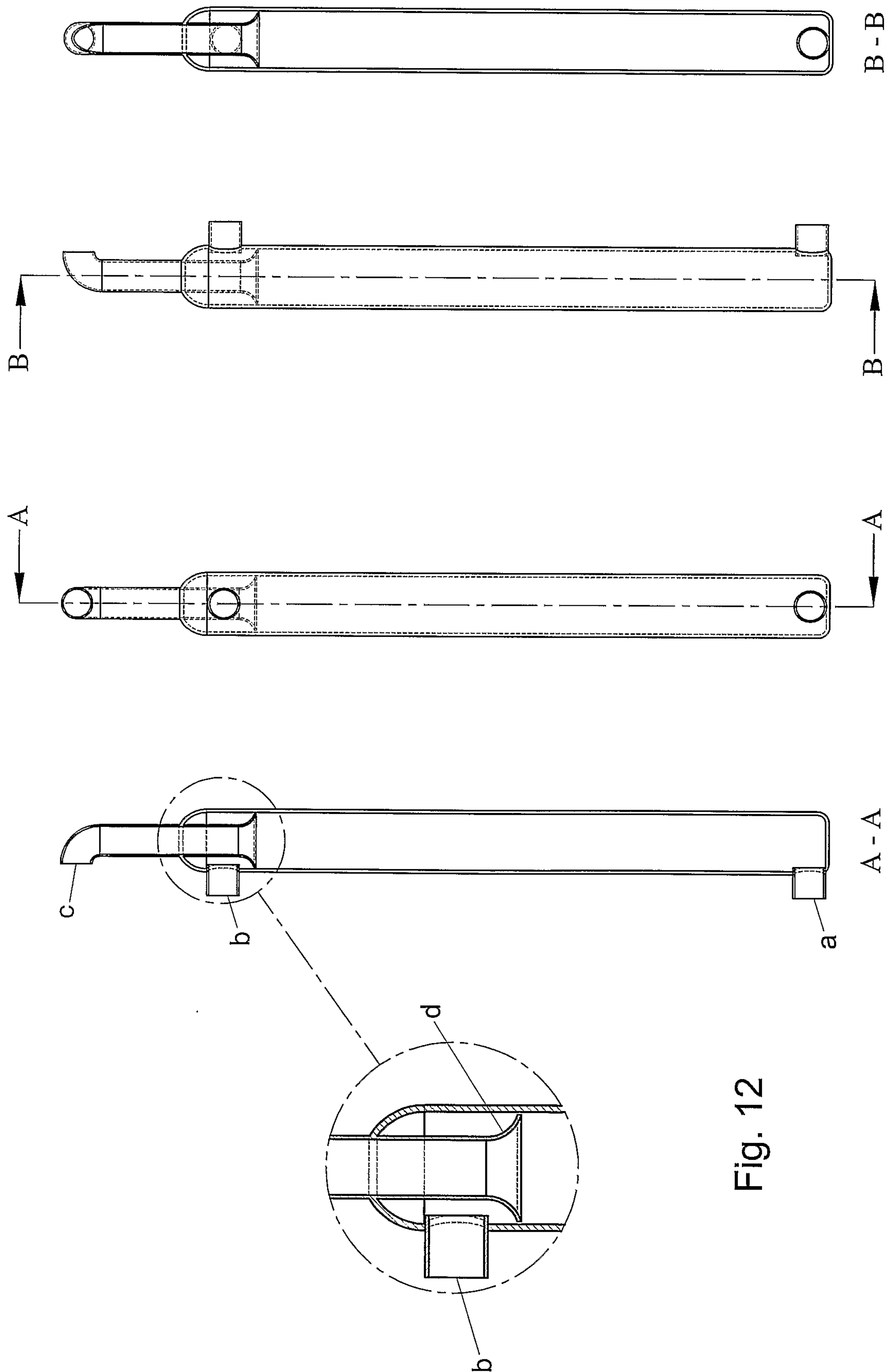

Fig. 12

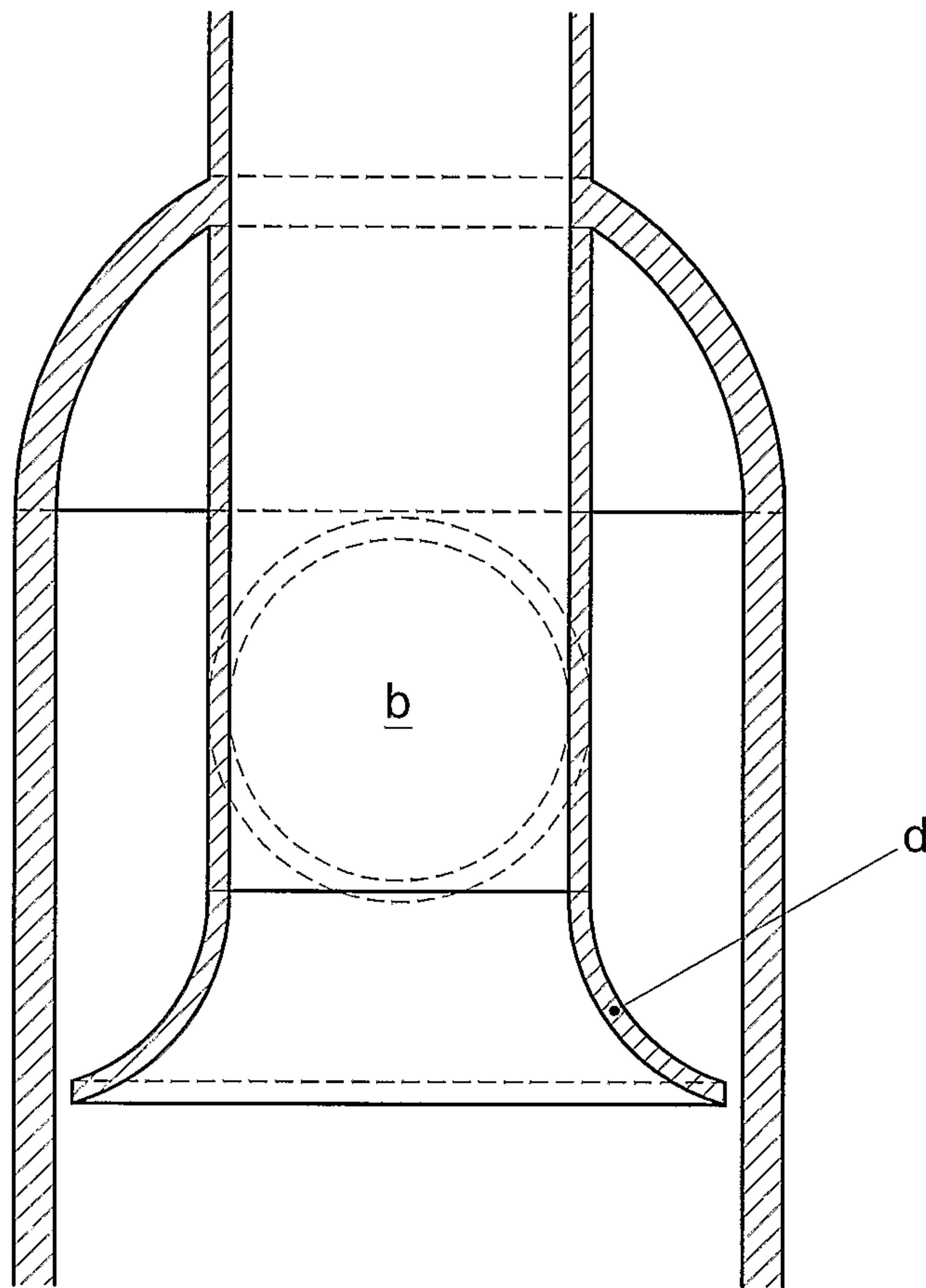

Fig. 13