



Europäisches Patentamt
European Patent Office
Office européen des brevets



(11) **EP 0 779 224 B1**

(12) **EUROPEAN PATENT SPECIFICATION**

(45) Date of publication and mention
of the grant of the patent:
10.10.2001 Bulletin 2001/41

(51) Int Cl.7: **B65D 5/50**, B65D 81/05

(21) Application number: **96118529.5**

(22) Date of filing: **19.11.1996**

(54) **Packaging for microwave-oven parts**

Verpackung für Teile eines Microwellenofens

Emballage pour des pièces d'un four à micro-ondes

(84) Designated Contracting States:
DE FR GB

(72) Inventor: **Yeo, Tae-Hong**
Changwon, Gyeongnam (KR)

(30) Priority: **11.12.1995 KR 9548317**
12.12.1995 KR 9548728

(74) Representative: **WILHELMS, KILIAN & PARTNER**
Patentanwälte
Eduard-Schmid-Strasse 2
81541 München (DE)

(43) Date of publication of application:
18.06.1997 Bulletin 1997/25

(73) Proprietor: **LG ELECTRONICS INC.**
Seoul (KR)

(56) References cited:
EP-A- 0 716 985 **DE-U- 9 217 901**
US-A- 2 997 164

EP 0 779 224 B1

Note: Within nine months from the publication of the mention of the grant of the European patent, any person may give notice to the European Patent Office of opposition to the European patent granted. Notice of opposition shall be filed in a written reasoned statement. It shall not be deemed to have been filed until the opposition fee has been paid. (Art. 99(1) European Patent Convention).

Description

Field of the Invention

[0001] The present invention relates to a holder for internal elements, such as a glass tray and a rotating ring having a roller of a packaged microwave oven as it is mentioned in the preamble of claim 1. Such a holder is known from the EP-A-0716985.

[0002] In a process for producing and transporting microwave ovens, the microwave ovens must be packaged prior to transporting them. That is, the microwave ovens are tightly packaged in respective boxes. Each typical microwave oven has a cubic configuration, so that the box for packaging the oven has a cubic configuration corresponding to the oven and has a size of being almost equal to that of the oven. While the ovens are packaged in the boxes, the internal elements of each oven, such as the glass tray and rotating ring, are preferably held in their places inside the cavity of the packaged oven, thus saving the internal space of the box and thereby achieving the recent trend of compactness of the packaged oven.

[0003] While a packaged oven is handled during transportation, the packaged oven may be carelessly impacted or vibrated, so that the oven's internal elements such as the glass tray and the rotating ring may move inside the oven's cavity, thus causing a scratch or damage of the cavity walls of the oven. In this regard, the above internal elements must be stably held in their positions inside the cavity of the packaged oven. In order to achieve the above object, the internal elements positioned inside the oven's cavity are held by a holder, which not only holds the internal elements but also absorbs and intercepts an external shock, thereby preventing the internal elements from moving inside the oven's cavity and from damaging the cavity wall.

[0004] Figs. 1A and 1B show the construction of a typical holder used for holding the internal elements inside the cavity of a packaged microwave oven. As shown in Figs. 1A and 1B, the holder comprises a packing table 2 and a retainer 3. The packing table 2 is placed in the lower space inside the cavity 1a of the oven 1, while the retainer 3 is placed above the packing table 2. The retainer 3 in the above state is tightly fitted between the top of the table 2 and the top wall of the oven's cavity 1a. The retainer 3 cooperates with the table 2 in order to hold the internal elements in their places inside the cavity 1a.

[0005] The above packing table 2 has a cubic configuration and is sized enough to be prevented from horizontal moving inside the cavity 1a when it is placed inside the cavity 1a. A stepped circular depression is formed on the center of the top of the above packing table 2.

[0006] The above stepped depression is divided into two seats, that is upper and lower seats having different diameters, by the step. The lower seat 2a of the stepped

depression has a smaller diameter and receives the rotating ring 4, while the upper seat 2b of the stepped depression has a larger diameter and receives the glass tray 5. Therefore, the lower seat 2a forms a rotating ring seat, while the upper seat 2b forms a glass tray seat.

[0007] The packing table 2 is preferably made of styrofoam, while the retainer 3 is preferably made of a corrugated cardboard. The corrugated cardboard is bent in order to form the retainer 3 having a triangular cross-section.

[0008] In order to hold the internal elements of the oven using the above holder before the oven is packaged in a box, the rotating ring 4 is seated in the lower seat 2a of the packing table 2 and the glass tray 5 is seated in the upper seat 2b prior to placing the packing table 2 inside the cavity 1a. After the packing table 2 is placed inside the cavity 1a, the triangular retainer 3 is placed above the top of the table 2. In the above state, the retainer 3 is tightly fitted between the top wall of the cavity 1a and the top of the table 2. The triangular bottom edge of the retainer 3 is laid across the top of the stepped depression of the table 2, so that the retainer 3 retains both the rotating ring 4 and the glass tray 5 in their seats 2a and 2b of the stepped depression of the table 2.

[0009] However, the above holder has a complex construction, so that the holder wastes labor, reduces work efficiency and takes too long while the microwave ovens are packaged. Another problem of the above holder is caused by the material of the packing table 2. That is, the styrofoam packing table 2 cannot be recycled, thus causing environmental pollution.

SUMMARY OF THE INVENTION

[0010] It is the object of the present invention to provide a holder for the internal elements of a packaged microwave oven which stably holds the oven's internal elements in their positions inside the oven's cavity.

[0011] In order to accomplish the above object, the holder of the present invention is constructed as it is mentioned in claim 1.

[0012] The holder has a length which is nearly equal to the diagonal length of the cavity. The holder is brought into close contact with the diagonally-opposite corners of the oven's cavity, thereby being prevented from moving inside the cavity. The holder comprises two side holder parts which tightly receive and hold the diametrically-opposite side portions of the glass tray. Each of the side holder parts is provided with a slot for receiving and holding the diametrically-opposite side portions of the glass tray. A bottom seat part extends inward from the bottoms of the side holder parts and hold the bottom of the glass tray. The above holder also includes two retaining flap parts which cover the top of the glass tray seated on the bottom seat part.

[0013] In the holder which is diagonally placed inside the oven's cavity, the diametrically-opposite side portions of the glass tray are inserted in and held by the

slots of the side holder parts, respectively. The bottom of the tray in the above state is held on the bottom seat part, while the top of the tray is covered with the retaining flap parts, so that the tray is stably held by the holder.

[0014] In addition, the rotating ring of the oven is held by the above holder. In this case, the rotating ring is seated above the glass tray inside the holder while holding the rollers of the rotating ring in the roller holding notches which are formed on the upper flaps of the retaining flap parts.

[0015] The above holder is preferably made of a corrugated cardboard which can be recycled while not causing environmental pollution. In order to form the holder, a plurality of bending lines and cutting lines are formed on a rectangular corrugated cardboard in accordance with the specifically-designed configuration of the holder. Thereafter, the cardboard is bent along the bending lines in order to form the holder.

BRIEF DESCRIPTION OF THE DRAWINGS

[0016] The above and other objects, features and other advantages of the present invention will be more clearly understood from the following detailed description taken in conjunction with the accompanying drawings, in which:

Figs. 1A and 1B are views showing the construction of a typical holder used for holding the internal elements inside the cavity of a packaged microwave oven, in which:

Fig. 1A is a perspective view showing the holder placed inside the oven's cavity; and

Fig. 1B is an exploded perspective view showing the construction of the holder and the oven's internal elements to be held by the holder;

Fig. 2 is a perspective view showing the configuration and construction of the holder in accordance with the primary embodiment of the present invention;

Fig. 3 is a development view of the holder of Fig. 2; Fig. 4 is a perspective view showing the holder of Fig. 2, when the developed board of Fig. 3 is bent into the holder;

Fig. 5 is a perspective view showing the holder of Fig. 2, which holds the internal elements and is placed inside the cavity of a microwave oven;

Fig. 6 is a development view of the holder in accordance with another embodiment of the present invention; and

Fig. 7 is a perspective view showing the holder of Fig. 6, when the developed board of Fig. 6 is bent into the holder.

DESCRIPTION OF THE PREFERRED EMBODIMENTS

[0017] Figs. 2 to 5 show the configuration, construction and operational effect of the holder in accordance with the primary embodiment of this invention. As shown in Figs. 2 to 5, the holder 6 has a single structure of a symmetric configuration and includes a bottom seat part, two retaining flap parts and two side holder parts. The above bottom seat part holds the bottom of the glass tray 4, while the retaining flap parts cover the top of the glass tray 4 seated on the above bottom seat part. Meanwhile, the side holder parts receive the diametrically-opposite side portions of the tray 4 thus holding the tray 4.

[0018] The above bottom seat part comprises two outside seats 6b and an inside seat 6a. Each of the outside seats 6b also forms the bottom of each of the above side holder parts and holds a side bottom portion of the glass tray 4. Meanwhile, the inside seat 6a comprises two semicircular members, which extend inward from the respective outside seats 6b and are connected together by a center rib. The above inside seat 6a holds the bottom center portion of the tray 4.

[0019] The retaining flap parts are provided on both sides of the above bottom seat part. Each of the retaining flap parts comprises a lower retaining flap 6f' and an upper retaining flap 6f. The upper flap 6f is bent in order to cover the top of the lower flap 6f'. The free edge of the upper flap 6f is provided with a roller holding notch 6e. The above notch 6e holds one roller 5a of a rotating ring 5, thus holding the rotating ring 5.

[0020] The side holder parts, which receive the diametrically-opposite side portions of the tray 4 thus holding the tray 4, are provided on both sides of the above bottom seat part. As described above, the outside seats 6b of the bottom seat part form the bottoms of the side holder parts. Each of the side holder part also has two side walls, that is, inner and outer side walls 6d and 6d' which extend upward from both sides of each outside seat 6b, respectively. The center of the inner side wall 6d is provided with a slot 6c which receives one side portion of the tray 4 in order to hold the tray 4. The outer side wall 6d forms the side wall of the holder.

[0021] The holder 6 of this invention is preferably formed of a corrugated cardboard. A method for forming the holder 6 using a corrugated cardboard is shown in Figs. 3 and 4.

[0022] Fig. 3 shows a developed board of the holder 6 of this invention. As shown in Fig. 3, an upper retaining flap 6f, which is provided with a roller holding notch 6e, is formed by making a first bending line on each side portion of the rectangular corrugated board. Thereafter, a second bending line is formed on the board at a position, which is spaced apart from and is parallel to the first bending line, thus forming an outer side wall 6d' having a predetermined width. The middle portion of the above board is linearly and roundly cut out in accord-

ance with the specifically-designed configurations of both the inside seat 6a and the lower retaining flaps 6f, thus forming the seat 6a and flaps 6f on the board. Third and fourth holding lines, which are spaced apart from and are parallel to each other, are formed on each side portion of the board in order to form both an outside seat 6b and an inner side wall 6d.

[0023] In Fig. 3, the dotted lines denote the bending lines, while the solid lines denote the cutting lines. After the cutting and bending lines are completely formed on the board, the board is bent along the bending lines as shown in Fig. 4, thus forming the holder 6. In order to hold the oven's internal elements by the above holder 6, the glass tray 4 is primarily seated on the bottom seat part of the developed board of Fig. 3. Thereafter, the board is bent along the third and fourth bending lines, thus forming the inner side walls 6d and the lower retaining flaps 6f. In this case, the holding slots 6c, which allow the diametrically-opposite side portions of the tray 4 to reach the interiors of the side holder parts of the holder 6, are formed on the center portions of the respective inner side walls 6d.

[0024] Thereafter, the board is bent along the first and second bending lines, thereby forming the outer side walls 6d' and the upper retaining flaps 6f. In the above case, each upper flap 6f is bent in order to cover the top of an associated lower flap 6f', so that the diametrically-opposite side portions of the tray 4 are covered with the upper flaps 6f.

[0025] The rollers 5a of the rotating ring 5 are inserted into the roller holding notches 6e of the upper flaps 6f, so that the rotating ring 5 is held by the holder 6.

[0026] The holder 6, which holds both the glass tray 4 and the rotating ring 5 therein, is diagonally seated in the oven's cavity 1a as shown in Fig. 5, thus stably holding the internal elements inside the cavity 1a prior to packaging the oven 1 in a box.

[0027] Figs. 6 and 7 show the holder in accordance with a second embodiment of the present invention. In this second embodiment, the configuration and construction of the holder 6' are equal to those of one side part of the symmetric holder 6 of the primary embodiment.

[0028] That is, different from the holder 6 of the primary embodiment, which has the inside seat 6a comprising the two semicircular members connected together by a rib into a symmetrical configuration, the holder 6' of the second embodiment has an inside seat 6a, which extends from an outside seat 6b and has an arcuate edge.

[0029] In addition, either side edge of each of the upper flap 6f, lower flap 6f' and outside seat 6b are smoothly curved in order to allow the holder 6 to be smoothly inserted into the oven's cavity 1a. In the above case, the curved edges of the upper flap 6f, lower flap 6f' and outside seat 6b preferably have the same radius of curvature.

[0030] In order to hold the oven's internal elements

using two holders 6' prior to packaging the oven 1 in a box, a first holder 6' is fully inserted into the oven's cavity 1a thereby being diagonally seated in the rear portion inside the cavity 1a. Thereafter, a second holder 6' is fitted over one side portion of the glass tray 4. In this case, the side portion of the tray 4 is fully inserted into the slot 6c of the second holder 6'. In addition, one roller 5a of the rotating ring 5 is inserted into the roller holding notch 6e of the second holder 6'. The second holder 6', holding both the tray 4 and the rotating ring 5, is diagonally inserted into the cavity 1a in order to insert the other side portion of the tray 4 into the slot 6c of the first holder 6' at the same time of inserting another roller 5a of the rotating ring 5 into the slot 6c of the first holder 6'. Therefore, the tray 4 and rotating ring 5 are stably and tightly held by the two holders 6' inside the cavity 1a.

[0031] The operational effect of the holder of this invention will be described hereinbelow.

[0032] In the holder 6, 6' of this invention, the length of the holder is nearly equal to the diagonal length of the cavity 1a, so that the holder 6, 6' is brought into close contact with diagonally-opposite corners of the cavity 1a, thereby being prevented from moving inside the cavity 1a.

[0033] Inside the above holder 6, 6', the bottom of the glass tray 4 is tightly held by the bottom seat part of the holder, while the top of the tray 4 is covered with the upper flaps 6f. In addition, the diametrically-opposite side portions of the tray 4 are tightly inserted into the slots 6c, so that the tray 4 is stably seated in the side holder parts. The rollers 5a of the rotating ring 5 are inserted in the roller holding notches 6e of the upper flaps 6f, so that the rotating ring 5 is also stably and tightly held by the holder 6, 6'.

[0034] The holder 6, 6' of this invention thus stably holds the oven's internal elements (the glass tray 4 and rotating ring 5) inside the cavity 1a of a packaged microwave oven 1, so that the holder 6, 6' prevents the internal elements from moving inside the cavity 1a even when the packaged oven 1 is carelessly impacted or vibrated while the packaged oven 1 is handled during transportation of the oven 1.

[0035] As described above, the present invention provides a structurally-improved holder for the internal elements of a packaged microwave oven. The holder of this invention has a simple construction and stably holds the oven's internal elements in their positions inside the oven's cavity. The above holder can be recycled, so that the holder does not cause any environmental pollution.

[0036] Although the preferred embodiment of the present invention have been disclosed for illustrative purposes, those skilled in the art will appreciate that various modifications, additions and substitutions are possible, without departing from the scope and spirit of the invention as disclosed in the accompanying claims.

Claims

1. A holder for internal elements, such as a glass tray (4) and a rotating ring (5) having a roller (5a) of a packaged microwave oven, comprising:
- 5 a bottom seat part (6a, 6b) for holding the bottom of said glass tray (4);
 at least two retaining flap parts (6f, 6f') provided on said bottom seat part (6a, 6b) for covering the top of said glass tray (4) seated on the bottom seat part (6a, 6b); and
 10 two side holder parts (6d, 6d') for tightly receiving and holding diametrically-opposite side portions of said glass tray (4)
- 15 said retaining flap parts (6f, 6f') comprising:
- a lower retaining flap (6f'), and
 an upper retaining flap (6f) covering the top of said lower retaining flap (6f'), **characterized in that** said upper retaining flap (6f) being provided with a roller holding notch (6e) for holding the roller (5a) of said rotating ring (5).
- 20
2. The holder according to claim 1, wherein said side holder parts (6d, 6d') are provided on both sides of said bottom seat part (6a, 6b), each of said side holder parts (6d, 6d') comprising:
- 25 inner and outer side walls, said inner side wall being provided with a holding slot (6c) for receiving a side portion of said glass tray (4) while said outer side wall forming a side wall of said holder.
- 30
3. The holder according to claim 1 or 2, wherein said bottom seat part (6a, 6b) comprises:
- 35 two outside seats adapted for holding diametrically-opposite side bottom portions of said glass tray (4); and
 40 an inside seat adapted for holding a bottom center portion of said tray (4).
4. The holder according to claim 3, wherein said inside seat comprises two semicircular members, said semicircular members extending inward from the respective outside seats and being connected together by a center rib.
- 45
5. The holder according to claim 1, 2, 3 or 4 wherein said holder is made of a corrugated cardboard.
- 50

Patentansprüche

1. Halter für innere Elemente eines verpackten Mikrowellenherdes, wie beispielsweise eine Glasschale (4) und einen sich drehenden Ring (5) mit einer Rol-

le (5a) mit:

- einem Bodenaufnahmeteil (6a, 6b) zum Halten des Bodens der Glasschale (4),
 5 wenigstens zwei Halteklappenteilen (6f, 6f'), die am Bodenaufnahmeteil (6a, 6b) vorgesehen sind, um die Oberseite der Glasschale (4), die im Bodenaufnahmeteil (6a, 6b) sitzt, zu überdecken, und
 10 zwei Seitenhalterteilen (6d, 6d') zum festen Aufnehmen und Halten der diametral gegenüber liegenden Seitenteile der Glasschale (4), wobei die Halteklappenteile (6f, 6f') eine untere Halteklappe (6f') und
 15 eine obere Halteklappe (6f) umfassen, die die Oberseite der unteren Halteklappe (6f') überdeckt, **dadurch gekennzeichnet, daß** die obere Halteklappe (6f) mit einer Rollhalterkerbe (6e) zum Halten der Rolle (5a) des sich drehenden Rings (5) versehen ist.
2. Halter nach Anspruch 1, bei dem die Seitenhalterteile (6d, 6d') auf beiden Seiten des Bodenaufnahmeteils (6a, 6b) vorgesehen sind, wobei jeder der Seitenhalterteile (6d, 6d')
- 25 innere und äußere Seitenwände umfasst, welche innere Seitenwand mit einem Halteschlitz (6c) zur Aufnahme eines Seitenteils der Glasschale (4) versehen ist, während die äußere Seitenwand eine Seitenwand des Halters bildet.
3. Halter nach Anspruch 1 oder 2, bei dem der Bodenaufnahmeteil (6a, 6b)
- 35 zwei Außenaufnahmen, die die diametral gegenüber liegenden Seitenbodenteile der Glasschale (4) halten können, und
 eine Innenaufnahme umfasst, die einen mittleren Bodenteil der Schale (4) halten kann.
4. Halter nach Anspruch 3, bei dem die Innenaufnahme zwei halbkreisförmige Elemente umfasst, welche halbkreisförmigen Elemente sich von den jeweiligen Außenaufnahmen nach innen erstrecken und über einen mittleren Steg miteinander verbunden sind.
- 45
5. Halter nach Anspruch 1, 2, 3 oder 4, welcher Halter aus Wellpappe besteht.

Revendications

1. , Pièce de maintien pour des éléments internes, tels qu'un plateau en verre (4) et un anneau rotatif (5) pourvu d'un rouleau (5a) d'un four à micro-ondes emballé, comprenant :
- 55

une pièce formant siège inférieur (6a, 6b), pour le maintien du fond dudit plateau en verre (4) ; au moins deux pièces formant volet de rétention (6f, 6f) ménagées sur ladite pièce formant siège inférieur (6a, 6b) pour couvrir la face supérieure dudit plateau en verre (4) installé sur la pièce formant siège inférieur (6a, 6b) ; et deux pièces de maintien latéral (6d, 6d') pour recevoir de manière serrée et maintenir des portions latérales diamétralement opposées dudit plateau en verre (4) lesdites pièces formant volet de rétention (6f, 6f) comprenant :

un volet de rétention inférieur (6f'), et un volet de rétention supérieur (6f) couvrant la face supérieure dudit volet de rétention inférieur (6f'), **caractérisée en ce que** ledit volet de rétention supérieur (6f) est pourvu d'une encoche (6e) de rétention du rouleau pour maintenir le rouleau (5a) dudit anneau rotatif (5).

2. Pièce de maintien selon la revendication 1, selon laquelle lesdites pièces de maintien latéral (6d, 6d') sont ménagées sur les deux côtés de ladite pièce formant siège inférieur (6a, 6b), chacune desdites pièces de maintien latéral (6d, 6d') comprenant:
 - des parois latérales intérieure et extérieure, ladite paroi latérale intérieure étant pourvue d'une fente de rétention (6c) pour recevoir une portion latérale dudit plateau en verre (4) alors que ladite paroi latérale extérieure forme une paroi latérale de ladite pièce de maintien.
3. Pièce de maintien selon la revendication 1 ou 2, selon laquelle ladite pièce formant siège inférieur (6a, 6b) comprend :
 - deux sièges extérieurs adaptés pour retenir des portions latérales diamétralement opposées du fond dudit plateau en verre (4), et un siège intérieur adapté pour retenir une portion centrale du fond dudit plateau (4).
4. Pièce de maintien selon la revendication 3, selon laquelle ledit siège intérieur comprend deux éléments semi-circulaires, lesdits éléments semi-circulaires s'étendant vers l'intérieur à partir des sièges extérieurs respectifs et étant connectés l'un à l'autre par une nervure centrale.
5. Pièce de maintien selon la revendication 1, 2, 3 ou 4, selon laquelle ledit élément de maintien est réalisé en carton ondulé.

FIG. 1

(A)

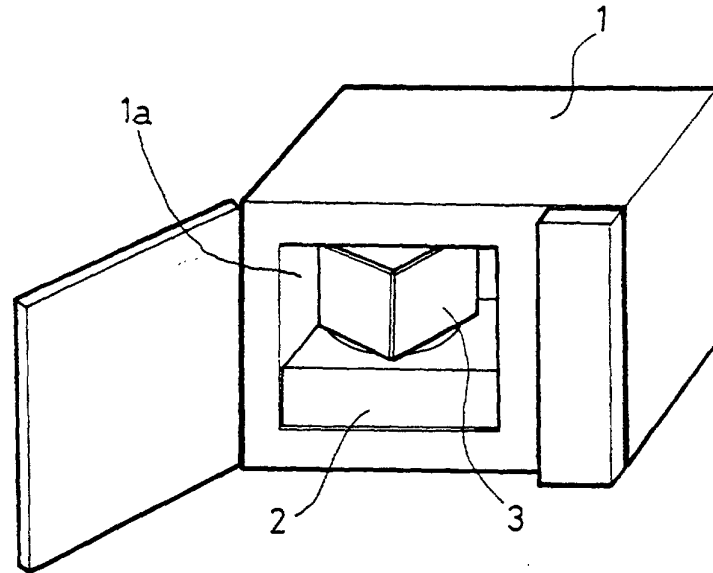

(B)

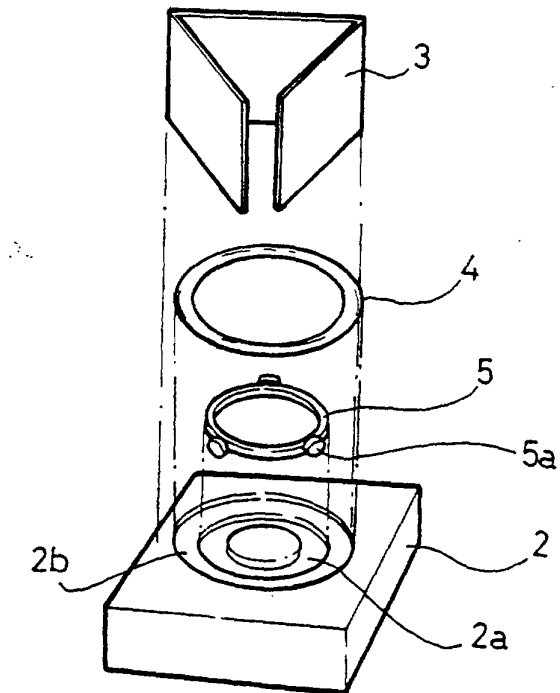

FIG. 2

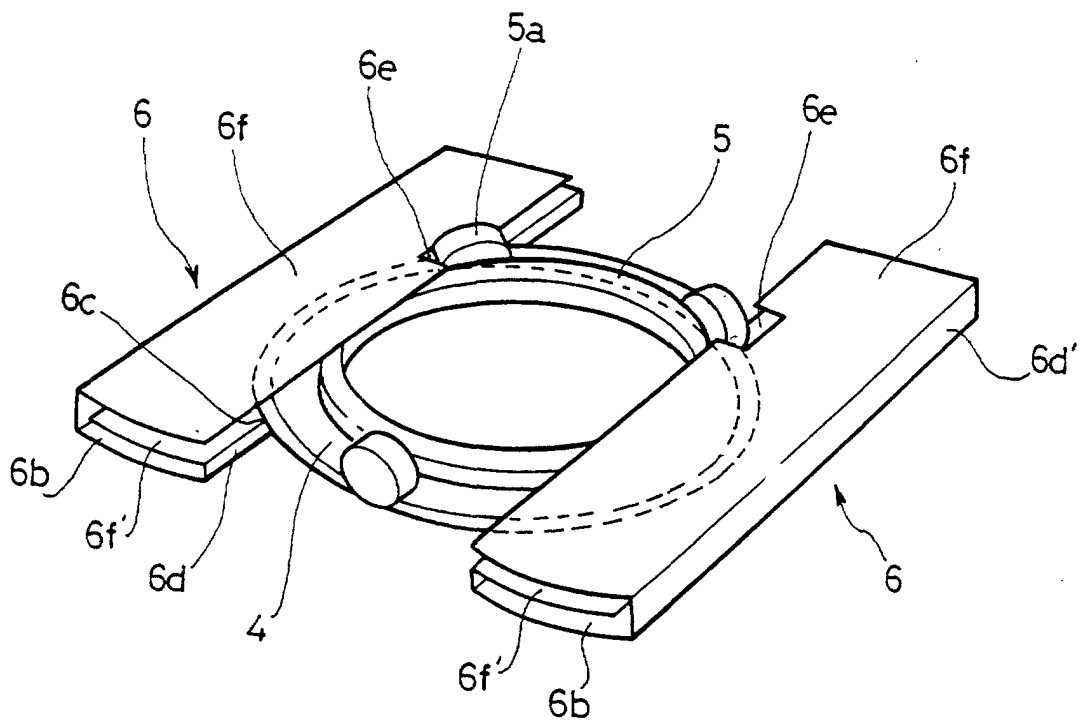

FIG. 3

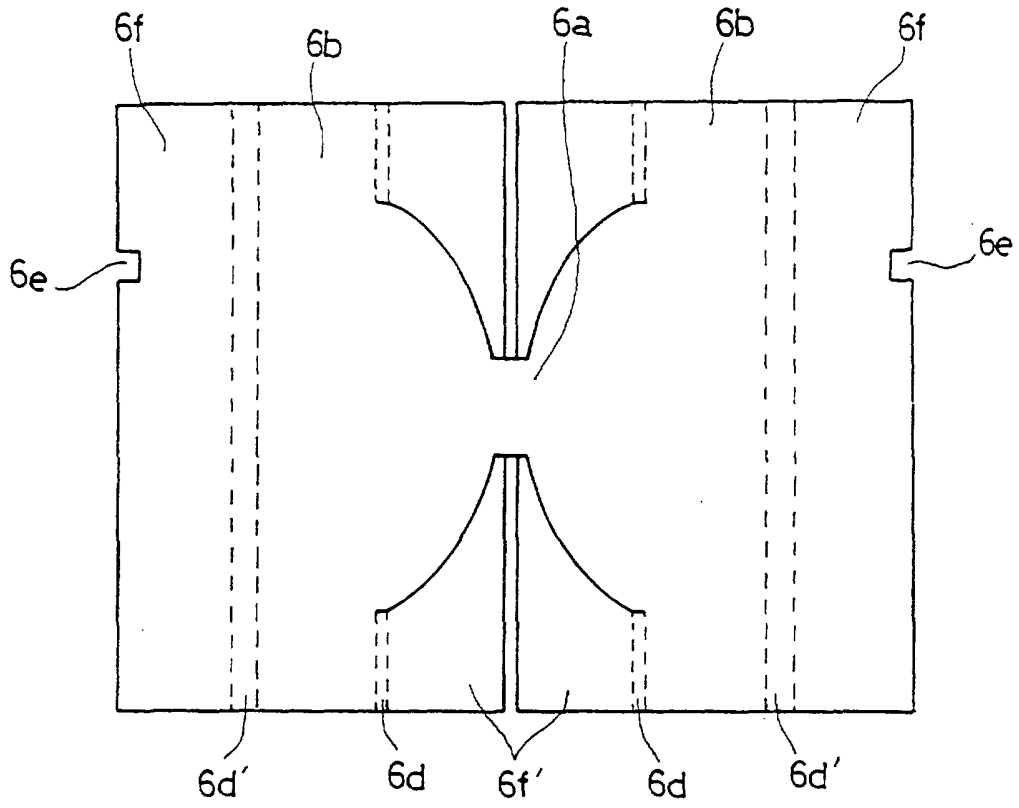

FIG. 4

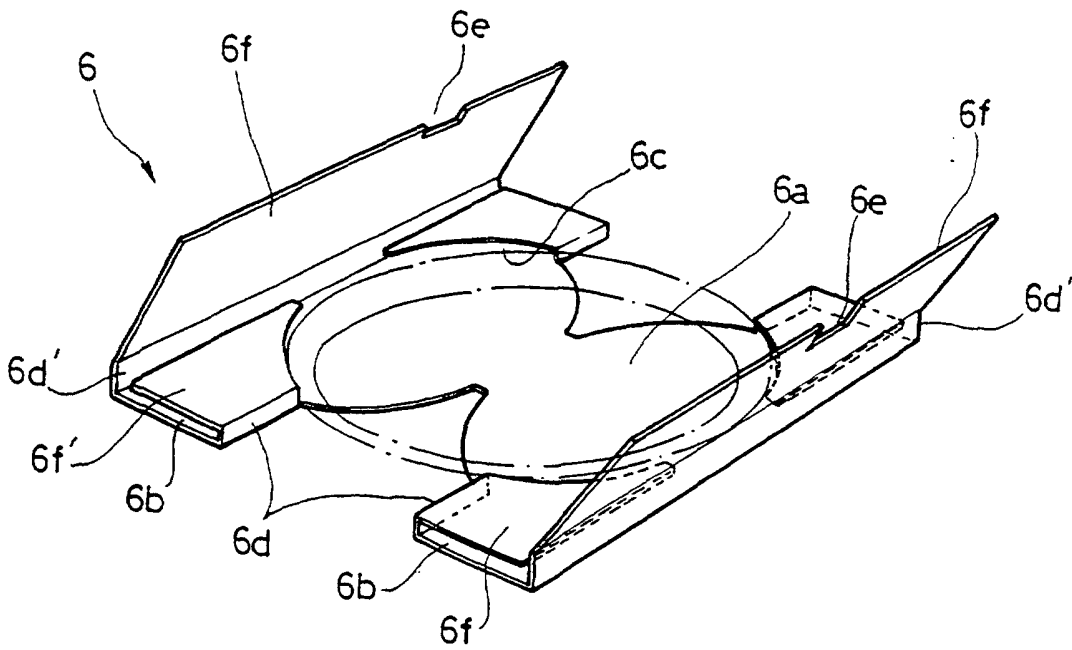

FIG. 5

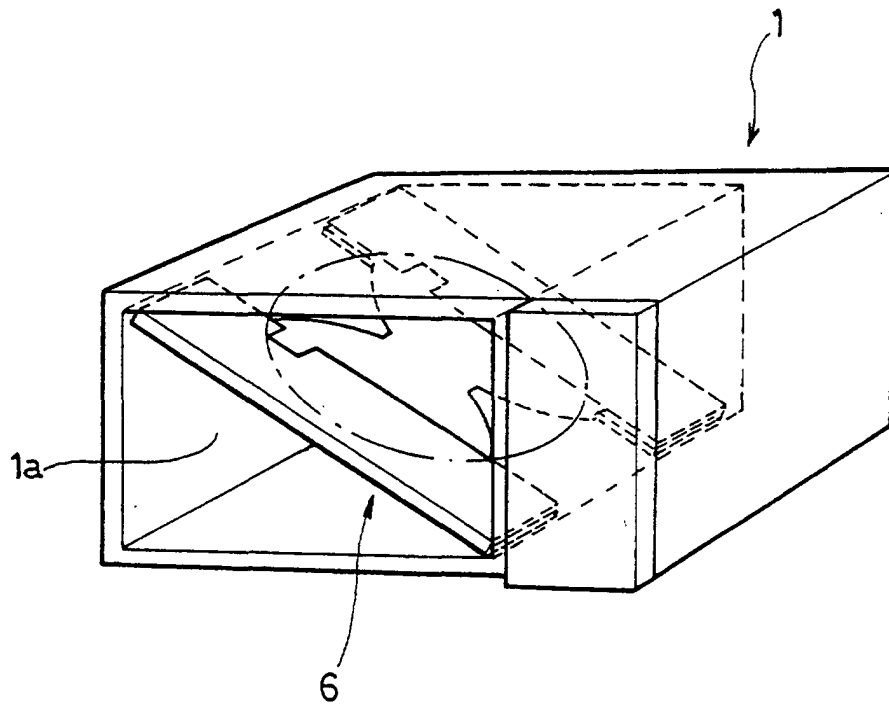

FIG. 6

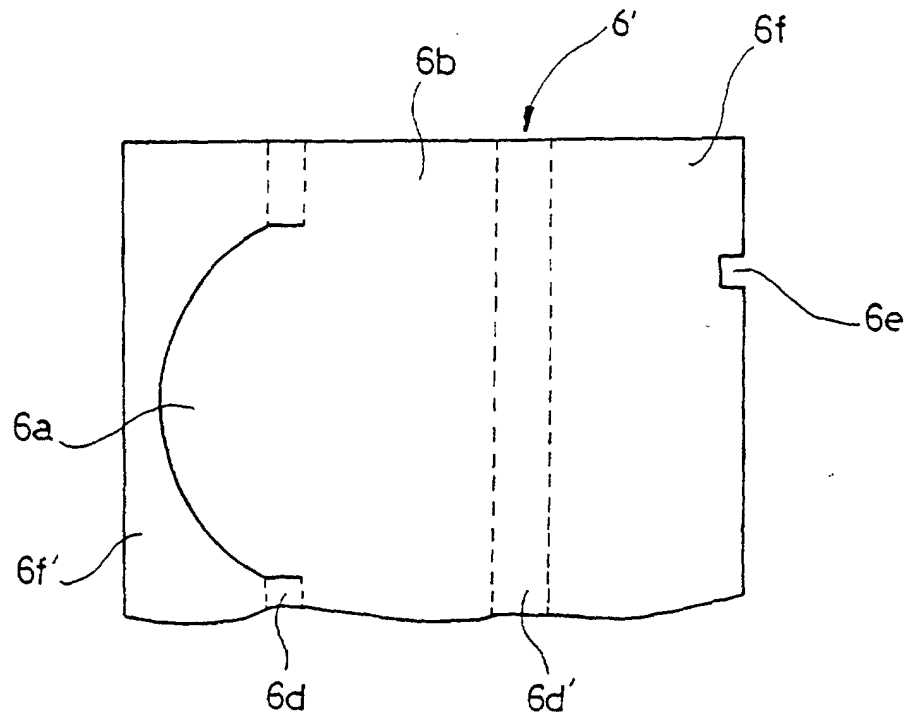

FIG. 7

