

Dec. 23, 1941.

J. E. MARTIN

2,267,531

HEATING UNIT

Filed April 25, 1938

2 Sheets-Sheet 1

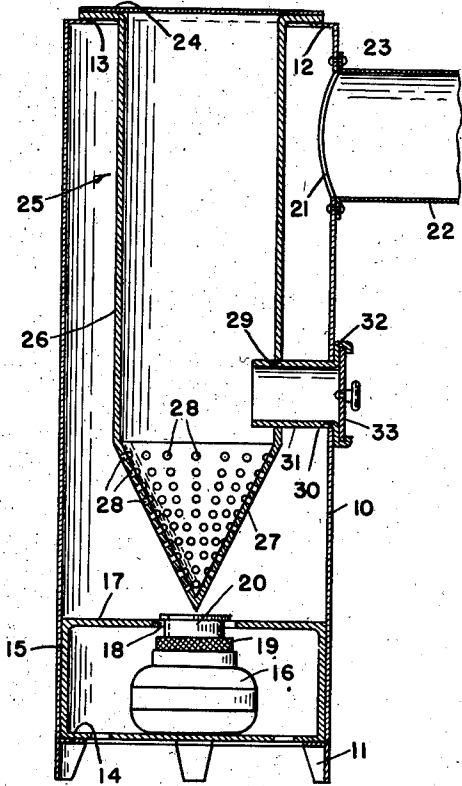

FIG. 2

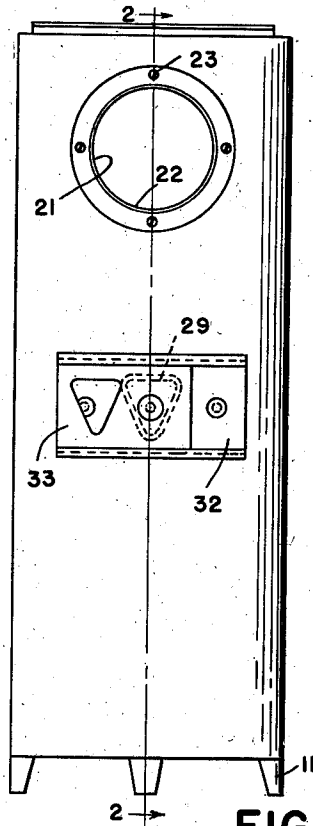

FIG. 1

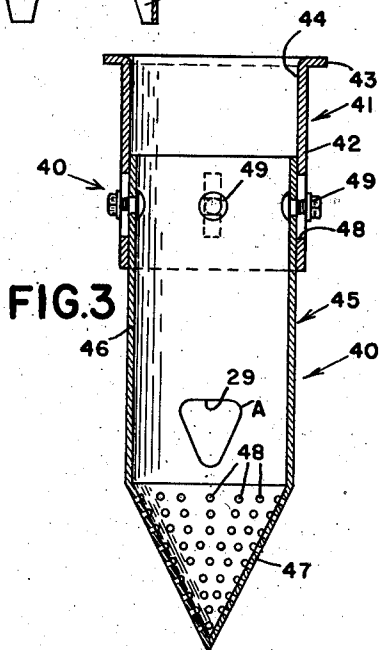

FIG. 3

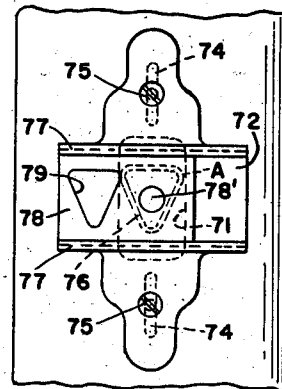

FIG. 7

INVENTOR
JESSE E. MARTIN

BY
Whittemore, Hullard & Belknap
ATTORNEYS

Dec. 23, 1941.

J. E. MARTIN

2,267,531

HEATING UNIT

Filed April 25, 1938

2 Sheets-Sheet 2

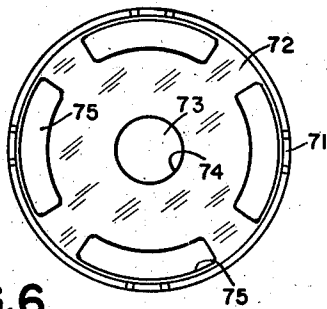
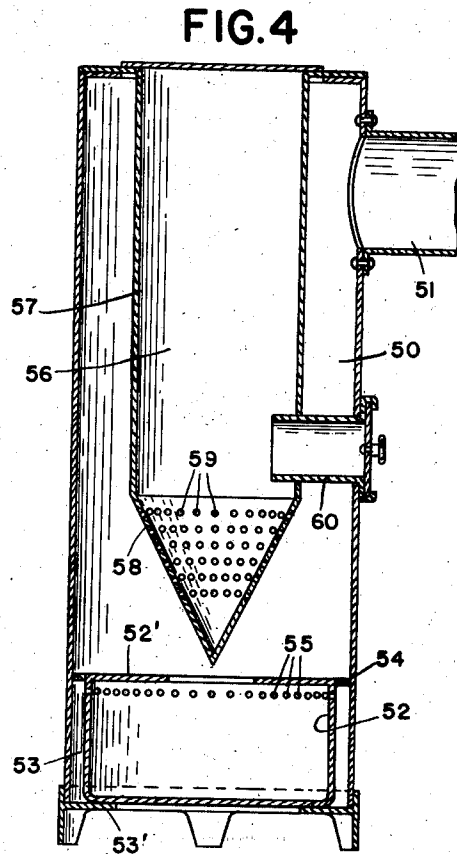
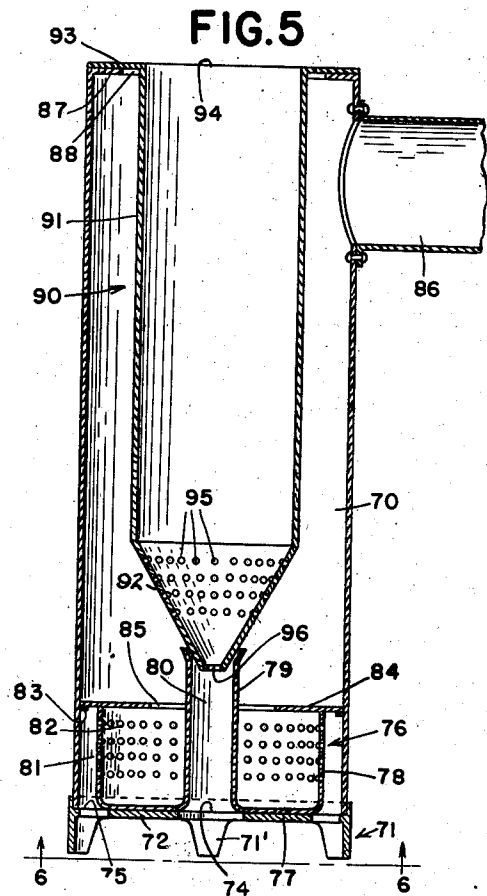

FIG. 6

INVENTOR
JESSE E. MARTIN

BY
Whittemore, Hulbert & Belknap
ATTORNEYS

UNITED STATES PATENT OFFICE

2,267,531

HEATING UNIT

Jesse Elmer Martin, Tampa, Fla.

Application April 25, 1938, Serial No. 204,169

13 Claims. (Cl. 126-93)

This invention relates to an improvement in unit heaters and particularly to unit heaters employing an oil or kerosene burner, although it is contemplated that the novel arrangement disclosed herein may be employed with other types of heaters, such for example as a solid fuel burner.

It is an object of the invention to provide in a unit heater having a casing an internal heat distributing member adapted to confine the hot products of combustion to a path closely adjacent the exterior casing of the heater.

It is a further object of the invention to provide in a unit heater a flame spreading attachment provided with a plurality of perforations for the purpose of supplying air for complete combustion.

It is a further object of the invention to provide in a unit heater a preheating air supply to the interior of the flame.

It is a further object of the invention to provide an attachment for unit heaters which comprises means for concentrating the products of combustion to a more useful path and to supply additional air to the flame.

It is a further object of the invention to provide an improved unit heater having means to increase the circulation of air and to simultaneously increase the air supply in a manner to render the combustion more efficient.

Other objects of the invention will be apparent as the description proceeds, and when taken in conjunction with the accompanying drawings, wherein

Fig. 1 is a side elevation of a unit heater embodying my invention;

Fig. 2 is a view partly in section on the line 2-2 of Fig. 1;

Fig. 3 is a sectional view of a modified form of attachment embodying my invention;

Fig. 4 is a side view partly in section showing another embodiment of my invention;

Fig. 5 is a side view partly in section showing still another embodiment of my invention;

Fig. 6 is a bottom plan view of the construction shown in Fig. 5;

Fig. 7 is a side view showing one form of draft regulator.

The heating unit illustrated in Figs. 1 and 2 comprises a casing 10 which may be of any convenient cross section but in the embodiment shown is cylindrical. Casing 10 is provided at the lower portion thereof with a plurality of spaced supporting feet 11 and at the top is provided with inwardly directed annular flange 12 defin-

ing an upwardly opening aperture 13. The feet 11 at their upper portions are provided with flat inwardly extending shoulders 14 for the purpose of supporting a chamber 15. In the event that the heating unit is to employ an oil or kerosene burner such as illustrated at 16, the chamber 15 is provided with an inwardly extending radial flange 17 defining a central opening 18. The burner 16 may be of any conventional type and for purposes of illustration, may be regarded as a kerosene burner having a wick 19 and a vertically adjustable flange controlling part 20. Near the upper portion of the casing 10 is provided an aperture 21 for the purpose of permitting egress of the products of combustion to a stack if desired. On the exterior of the casing is indicated a short section of pipe 22 for the purpose of connecting the aperture to the stack and the pipe 22 is shown as secured surrounding the aperture 21 as by means of a flange 23.

Supported centrally in the aperture 13 as by means of an outwardly extending radial flange 24 is my improved combustion improving and circulation controlling distributor member 25. The member 25 comprises essentially a cylindrical portion 26 which terminates at its lower end in a conical portion 27 provided with a plurality of spaced apertures 28.

The member 25 in its cylindrical portion 26 is provided with an opening 29 for the purpose of providing admission of air into the interior of the member 25. A corresponding shaped opening 30 is provided in registering relation in the outer wall of the casing 10 and the two openings 30 are interconnected by a pipe or conduit 31 which in the embodiment shown is secured to the exterior of the casing 10 as by flanges 32. A suitable draft regulator 33 of any convenient type is provided for the purpose of controlling the passage of air through the conduit 31.

The conduit 31 in the embodiment shown as a cross section which is an isosceles triangle with its vertex directed downwardly. It will be obvious, of course, that the shape of this conduit 31 may be varied at will and may, if desired, for convenience be made circular in cross section. I have found, however, that by employing the conduit 31 which is triangular in cross section and locating the same directly beneath the aperture 21, certain improved results are obtained which will be discussed more fully later.

From the foregoing description the operation of my improved heater will be apparent. Combustion occurs at the wick 19 and in a zone immediately thereabove. As is a matter of com-

mon knowledge, the wick type burners of this type normally fail to accomplish complete and efficient combustion. As a result of this, in the zone immediately above the burner unit 16 there will be a mixture of flames and hot products of combustion. These flames and hot products of combustion will be deflected outwardly by the conical portion 27 of the member 25 and caused to follow the restricted annular path included between the casing 10 and the cylindrical portion 26 of member 25. As a result of this, there will be increased heat transfer from the products of combustion to the exterior wall 10 of the burner, and a transfer of heat to the wall of member 25. The products of combustion eventually are led to a stack through the aperture 21 by means of a conduit 22 if desired. Under certain circumstances, it may be practicable to permit these products of combustion to escape into the room, particularly since by my improved construction, combustion of the inflammable materials is substantially complete.

In order to increase combustion, the apertures 28 are provided in the conical portion 27, and the conduit 31 is provided to connect the interior of member 25 with the atmosphere.

The hot products of combustion being deflected outwardly by the conical portion 27 and rising in the annular space between casing 10 and member 25, creates a draft which tends to draw air from the interior of member 25 therethrough the apertures 28. This air passes into the hot products of combustion flame and incompletely consumed combustion material at spaced points, as a result of the spacing of apertures 28. This addition of air at this point results in highly efficient and substantially complete combustion. It will be understood of course, that the conical portion 27 of the member 25 becomes highly heated and the air admitted through the apertures 28 is substantially preheated. This result is further increased by the admission of air through the conduit 31, which lies in the path of the hot products of combustion. Air will be drawn through the conduit 31 into the interior of the burner 25 and this air will be substantially preheated before it reaches the interior of the burner 25, which tends to increase the efficiency of the combustion. Member 25 may be open at the top. Instead of providing the member 25 with an upwardly opening top, it may be closed at the top, in which case flow of air through openings 28 is controlled by the conduit 31, thus giving an accurate control of the amount of air provided. In this latter case, as will be apparent, the supply of air received within the member 25 is substantially heated, with the result that the air introduced into the combustion zone through the apertures 28 will be in a condition to readily support combustion.

As referred to above, I have found that by placing the conduit 31 directly beneath the outlet 21 to the stack, other important advantages are obtained. The member 31, under these circumstances, serves the additional function of a deflector member and prevents direct passage of hot products of combustion from the combustion zone to the stack. The shape of the conduit 31, that is, triangular with a vertex directed downwardly, further increases this effect since it has a tendency to control the direction of the upwardly rising convection currents composed of the hot products of combustion. The triangular shape deflects these products of combustion away from the opening 21 and sets up a swirling mo-

tion which has the effect of further increasing the transfer of heat to the casing 10.

I have found that by employing my member 25 in a heating unit of the type disclosed, the overall efficiency of the heating unit is increased by a remarkable amount. This increase in the overall efficiency of the heating unit is to be explained by the increased heat transfer due to the efficiently restricted passage for the hot products of combustion; by the increased efficiency of combustion due to the supply of air at the points where it is most efficiently utilized, and by the substantial preheating of the additional air supply before it reaches the flame.

In Fig. 3 I have illustrated a slightly modified form of attachment 40 which includes all of the advantages inherent in the member 25 shown in Fig. 2, but is rendered further useful by providing the same in a telescopic arrangement. Member 40 comprises an upper section 41 which is essentially a cylinder 42 provided at its upper end with an outwardly extending radial flange 43 for supporting the same upon a heating unit in the manner illustrated in Fig. 2. The member 41 may be open at the top as indicated at 44 or may be closed by an integral or separate closure if desired. The lower portion 45 of the member 40 comprises a cylindrical portion 46 of a size adapted to be received within the cylindrical portion 42. The lower portion 45 terminates in a conical portion 47 provided with a plurality of spaced apertures 48 corresponding to the apertures 28 of the member 25 shown in Fig. 2. The lower portion 45 is further provided with an aperture 29 which is adapted to be connected by a suitable conduit corresponding to the conduit 31 shown in Fig. 2 for the purpose of leading air into the interior of the member 40.

Due to the telescopic relationship of the parts 41 and 45, the over-all length of the member 40 may be adjusted to adapt the same to different size unit heaters or to adjust the same to obtain the most efficient results from a unit heater. The upper portion 41 is provided with a plurality of vertical slots 48 and threaded adjacent the upper portion of the lower member 45 are a plurality of headed bolts 49 adapted to be received within the slots 48. As is obvious, by loosening the bolts 49 the parts 41 and 45 may be adjusted and substantially clamped in adjusted position by tightening the bolts 49. The operation of the modified form of member 40 is parallel in all respects to the operation of member 25 shown in Fig. 2.

In both of the embodiments previously described, it is to be understood that while I have illustrated the same for purposes of clearness in connection with a kerosene wick type burner, that the construction disclosed is capable of use with other types of burners, such for example as gas, oil, or solid type fuel such as coal or coke.

I have illustrated in Fig. 4 a slightly different embodiment of my invention which is in many respects similar to that shown in Fig. 2 and which will be described with particularity only with reference to the differences therefrom. In Fig. 4 the casing 50 is provided with a pipe 51 leading to the stack and is adapted to support near its bottom a chamber 52. The chamber 52, as will be noted, is somewhat smaller than the diameter of the casing 50 and as a result an annular passage 53 is provided between the exterior of the chamber 52 and the interior of the casing 50. The casing 50 is open at the bottom and rest upon spaced projections 53' so that air may pass up-

wardly through the annular passage 53. A ring 54 is provided at the upper portion of the annular passage 53 and closes the same. The ring 54 may be carried by the interior of the casing 50 or may be carried by the exterior of the chamber 52, or if desired, may be a separate element resting upon the top of the chamber 52. The chamber 52 is provided at its top with an inwardly extending radial flange 52' which defines a central upwardly opening aperture.

In order to provide for a desirable circulation of air into the chamber 52, a plurality of apertures 55 are provided adjacent the top of the chamber 52 and interconnect the annular passage 53 with the interior of the chamber. The chamber 52 is adapted to support a heating unit which may be a conventional wick type oil or kerosene burner, a gas burner or a solid fuel burner.

This unit is provided with the distributor member 56 which is substantially identical with the distributor member 25 illustrated in Fig. 2, being provided with a substantially cylindrical portion 57 and a conical portion 58, having a plurality of apertures 59 therein. A conduit 60 herein is illustrated as triangular but may take any desirable shape, and is employed to interconnect the interior of member 56 with atmosphere outside the casing 50. A suitable control means in the form of a damper or valve will be provided to control the passage of air through conduit 60. In this embodiment of my invention as in the embodiment illustrated in Fig. 2, the member 56 may be open at the top, or if desired may be closed, so that the air supplied through apertures 59 may be accurately controlled by a damper controlling the conduit 60.

A somewhat different embodiment of my invention is illustrated in Figs. 5 and 6, in which a casing 70 is provided which is open at its top and bottom and in the embodiment shown is cylindrical. Adjacent the bottom portion of the casing 70 is a support 71, having feet 71' provided with a flat supporting surface 72. Surface 72 has a central opening 74 as best seen in Fig. 6, and a plurality of spaced circumferentially extending apertures 75. The base plate 72 is adapted to support thereon a fire pot 76, which has an imperforate annular bottom 77, exterior cylindrical wall 78 and an interior cylindrical wall 79 defining a central passage 80 through the fire pot. The interior wall or conduit 79 extends substantially above the upper edge of the exterior wall 78. The exterior wall 78 is of a diameter to provide a substantial annular space 81 between the same and the interior of the wall of the casing 70. A plurality of apertures 82 are provided completely around and from the top to a point adjacent the bottom of the wall 78.

The interior wall of the casing 70 is provided with an inwardly extending annular flange 83, upon which is supported an annular plate 84 having a central aperture 85 surrounding and relatively widely spaced from the conduit 79.

It will be obvious that in the operation of the device air will be drawn upwardly through apertures 75 to pass into the annular passage 81 through the apertures 82 into the interior of the fire pot and the products of combustion will then rise through the annular passage defined by the aperture 85 as restricted by conduit 79.

The casing 70 is provided adjacent its top with a pipe 86 which carries the products of combustion to the stack. The casing 70 is further provided at its top with an inwardly extending

radial flange 87 which terminates close to the wall of the casing 70 and provided an upwardly opening central aperture 88. A distributor member 90 is provided which comprises essentially a cylindrical portion 91. At the top of the cylindrical portion 91 the member 90 carries an outwardly projecting radial flange 89 adapted to rest upon the inwardly directed flange 87 and to support the member 90. In this modification, the member 90 is open at its top as indicated at 94 for a purpose which will be more fully described later.

The conical portion 92 of the member 90 is provided with a plurality of perforations for supplying air to the products of combustion in the combustion zone. In this modification as in the others previously described, the conical portion serves to deflect the hot products of combustion into the relatively narrow passage provided between casing 70 and the cylindrical portion 91 of member 90. This, as will be obvious, increases the transfer of heat from the hot products of combustion to the exterior of the casing.

In the preceding paragraph the annular passage provided between the casing 70 and the cylindrical portion 91 of the member 90 was referred to as relatively narrow. This refers to the width of the annular passage as measured between a point on the wall of the casing 70 to the nearest point on the wall of the cylindrical portion 91, and this width is narrow as compared to the width of the cylindrical portion 91. By making this annular passage relatively narrow, the hot products of combustion are spread out in a relatively thin layer, so that heat transfer outwardly through the wall of the casing 70 to the space and inwardly through the cylindrical portion 91 to the air contained therein is substantially increased. At the same time a measurable restriction to flow of the hot products of combustion is afforded by reason of the aforesaid relative narrowness of the annular passage. It will be appreciated that the precise proportions illustrated in the figures (Figures 2 and 4, as well as Figure 5) need not be followed, and improved results will be obtained even though the annular passage referred to is considerably wider. However, it is desirable in all cases to provide the central tubular portion 91 of the member 90 of very substantial width, so as to provide a substantial area for transfer of heat from the annular passage to the interior of the cylindrical portion 91. It is this transfer of heat and the resultant heating of the air contained within the cylindrical portion 91 which causes convection therein in a manner to cause the heated air to pass upwardly through the open end thereof into the space being heated.

The fire pot 76 is supported by the plate 72 so that the passage 80 defined by the central or interior conduit 79 registers with the central aperture 74 in the plate 72. As a result of this, air will be drawn by convection through the passage 80. In this modification the conical member 92 differs from those previously described in that it terminates at its lower end in an aperture 93. Air drawn upwardly through passage 80 enters through the aperture 93 into the conical portion of the member 90 and some of this air is drawn outwardly by the natural drafts created through apertures 95 and supplied to the combustible material in the combustion zone. This air it will be noted is substantially preheated by its passage through the conduit 79 and is additionally preheated by its passage through t

apertures 95, since the conical portion 92 of the member 90 will be heated to high temperature by the combustion.

In this modification the air supplied through the passage 80 and into the interior of the member 90 is more than is required to supply combustion air through the aperture 95. A substantial amount of air will continue upwardly through the cylindrical portion 91 where it will be substantially heated and will pass into the space being heated through the top openings 94 previously referred to.

In Fig. 7 I have illustrated an air supply control means which corresponds to that shown at 32, 33, in Fig. 2. In the embodiment shown in Fig. 7, however, provision is made for vertical adjustment of the air control member, in order to cooperate with an adjustable unit, such as disclosed in Fig. 3. For this purpose, a vertically elongated aperture 71 is provided in the outer casing of the heater unit. A correspondingly curved plate 72 is secured over the aperture 71 and vertical adjustment of the plate 72 is provided. For this purpose elongated tabs 72 project upwardly and downwardly from the plate 72 and the tabs are provided with vertically elongated slots 74. Suitable securing means such for example as clamping bolts 75, are provided, and these are adapted to be threaded into tapped holes in the casing and to clamp the plate 72 in vertically adjusted position.

The plate 72 is provided with a generally triangular aperture 76 which in all positions of adjustment is adapted to register with a portion of the aperture 71 previously referred to. The plate 72 is also provided with flanges 77 which are bent to provide a slideway for the slidable draft controlled member 78. The draft control member 78 is provided with triangular aperture 79 and with a button 78' for the purpose of moving the member 78 horizontally in the arcuate slides defined by the flanges 77. It will be apparent that in the position shown the air supply to the interior of the unit is prevented, since the aperture 79 is out of registry with the conduit connecting the aperture 76 with the interior of the unit.

It will be understood that except for the provision for vertical adjustment illustrated in Fig. 7, the air supply control parts illustrated in Figs. 1 and 2 may be and preferably are identical with that shown in Fig. 7.

Essentially, the modifications described all show a combustion and circulation controlling member which is adapted to direct the hot products of combustion into restricted passages where they will be in intimate contact with the heating surfaces of the heating unit. In addition, all of the embodiments disclosed show means for introducing air into the combustion zone at the point where the additional combustion air may be most efficiently utilized. This air it should be noted in all cases is supplied in effect at the interior of the flame, other sources supplying air to the exterior of the flame. This air which is supplied to the interior of the flame at the point where it may be most efficiently utilized is in all cases substantially preheated with the result that the efficiency of combustion is substantially increased. While in certain modifications for convenience I have illustrated a particular embodiment of my invention in combination with a particular burner, as for example a wick type burner in Fig. 2, it is to be distinctly understood that my invention is not to be re-

stricted to the use of any particular type of burner but instead is to include the use of any burner which is adaptable therefor, as will be readily understood by those skilled in the art.

The foregoing detailed description has been given for clearness of understanding only, and no unnecessary limitations should be understood therefrom, but the appended claims should be construed as broadly as permissible in view of the prior art.

What I claim as my invention is:

1. A heater comprising a casing, a burner at the base of said casing, a vertical conduit extending through said burner and casing, and defining an annular passage with the walls of said casing, said casing and conduit both being of substantial diameter, so that said annular passage is narrow as compared to the width of said conduit, said conduit being perforated in the combustion zone, whereby air circulating upward through said conduit is in part emitted through the perforations into the zone of combustion, and in part is discharged in heated condition from the upper end of said conduit.

2. A heater comprising a casing, a burner at the base of said casing, a vertical conduit extending through said burner and casing, and defining a narrow annular passage with the walls of said casing, said conduit being upwardly and outwardly tapered and perforated in the combustion zone, whereby air circulating upward through said conduit is in part emitted through the perforations into the zone of combustion, and in part is discharged in heated condition from the upper end of said conduit.

3. A heater comprising a casing, a burner at the base of said casing, a vertical conduit extending through said burner and casing, and defining a narrow annular passage with the walls of said casing, said conduit being perforated in the combustion zone, whereby air circulating upward through said conduit is in part emitted through the perforations into the zone of combustion, and in part is discharged in heated condition from the upper end of said conduit, said narrow annular passage having a vent for emitting the products of combustion.

4. A heater comprising a casing having a lower combustion space, an air supply member located centrally in said space and having the form of a hollow inverted, closely perforated cone, a tubular heat exchange element above said combustion space open at the top and defining a central air heating space communicating with the interior of said air supply member, said tubular member being of substantial height to establish a positive draft through said combustion space, a conduit connecting the bottom of said air supply member, whereby air is drawn into said air supply member by convection, a portion of such air is drawn through the perforations in said air supply member outwardly into the combustion space, and the balance of said air rises by convection through said heat exchange element into the space to be heated.

5. The heater as defined in claim 4, in which said conduit extends downwardly from said air supply member and opens to atmosphere at the bottom of said casing.

6. A heater comprising a casing having a lower combustion space, an air supply member located centrally in said space and having the form of a hollow inverted, closely perforated cone, a tubular heat exchange element above said combustion space open at the top and defining a central air

heating space communicating with the interior of said air supply member, said tubular member being of substantial height to establish a positive draft through said combustion space, an annular fire pot in the bottom of said casing providing a conduit connecting to atmosphere therethrough, said air supply member being open at its bottom and communicating with said conduit.

7. A heater comprising a casing having a lower combustion space, an air supply member located centrally in said space and having the form of a hollow inverted, closely perforated cone, a tubular heat exchange element above said combustion space open at the top and defining a central air heating space communicating with the interior of said air supply member, said tubular member being of substantial height to establish a positive draft through said combustion space, an annular fire pot in the bottom of said casing spaced inwardly from the sides of said casing and being apertured for admission of air, and providing a conduit connecting to atmosphere therethrough, said air supply member being open at its bottom and communicating with said conduit.

8. As an article of manufacture, a unit for insertion into a heater casing, said unit comprising an open topped hollow cylindrical portion adapted to be suspended from the top of a heater casing and to open to atmosphere at its top, and a lowermost conically tapered portion communicating with said cylindrical portion, said tapered portion being perforated, said unit being apertured below the open top of said cylindrical portion for connection with a conduit leading to atmosphere.

9. A casing having a lower combustion space therein, a tubular member in said casing extending from the top thereof to a point within said combustion space, said member being of substantial size to define with said casing an annular passage for products of combustion which is narrow as compared to the width of said member, said member being open to atmosphere at its top, said member being provided with apertures adjacent its lower end to provide for passage of air outwardly therefrom into the combustion space, said member being connected to atmosphere at a point substantially below the open top thereof.

10. A casing having a lower combustion space therein, a hollow member in said casing extending from the top thereof to a point within said combustion space, said member being of substantial size to define with said casing a relatively restricted, annular passage for products of combustion, said member being open to atmosphere at its top, said member being provided with apertures adjacent its lower end to provide for passage of air outwardly therefrom into the combustion space, said member being connected to

atmosphere at a point substantially below the open top thereof.

11. A casing having a lower combustion space therein, a tubular member in said casing extending from the top thereof to a point within said combustion space, said member being of substantial size to define with said casing an annular passage for products of combustion which is narrow as compared to the width of said member, said member being open to atmosphere at its top, said member being provided with apertures adjacent its lower end to provide for passage of air outwardly therefrom into the combustion space, and a conduit connected directly to the lower portion of said member and opening to atmosphere.

12. A heater comprising a casing having a lower combustion space, a distributor member located centrally in said space and having a tubular upper portion defining with said casing an annular passage for products of combustion, said tubular upper portion being open at its top to provide for escape of warmed air, said distributor member having a lower portion located in the combustion space and provided with apertures therethrough, air supply means connecting said distributor member to atmosphere at a point substantially below the open top of said distributor member, said annular passage being of substantial height and the parts being constructed and arranged whereby air admitted through said air supply means in part is drawn into said combustion space through said apertures and in part flows upwardly by convection and is discharged through the open top of said tubular portion of said distributor member.

13. A heating unit comprising a casing having a lower combustion space therein, a hollow member in said casing having a tubular upper portion of relatively large size defining with said casing an annular passage for products of combustion, said member having a lower portion located in said combustion space, said lower portion being downwardly and inwardly tapered and provided with a plurality of apertures, the tubular upper portion of said member being open to atmosphere at its top, an air inlet conduit communicating with the interior of said member substantially below the open top thereof, said casing having a flue connection adjacent the top thereof, the parts being constructed and arranged such that air flowing into said member through said conduit divides and some of said air enters said combustion space through said apertures, and the rest of said air flows upwardly through the tubular upper portion of said member, where it is heated, and is discharged through the open top thereof.

JESSE ELMER MARTIN.