

C. F. FULMER & W. E. KELVIE.  
PLANER CHUCK.

No. 455,196.

Patented June 30, 1891.

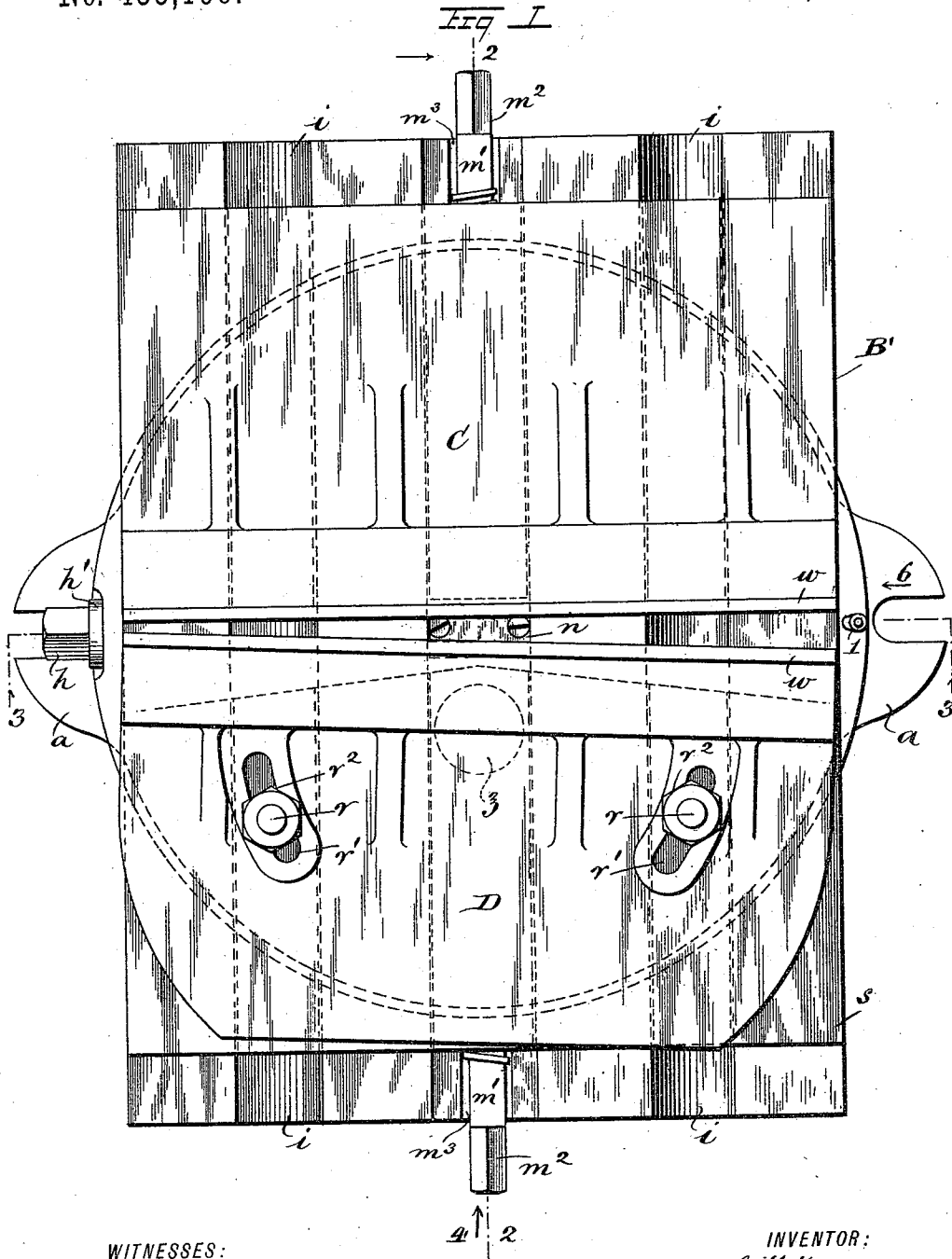

WITNESSES:  
*H. Walker*  
*C. Sedgwick*

INVENTOR:  
*C. F. Fulmer*  
 BY *W. E. Kelvie*  
*Munn & Co.*  
 ATTORNEYS

# C. F. FULMER & W. E. KELVIE. PLANER CHUCK.

No. 455,196.

Patented June 30, 1891.

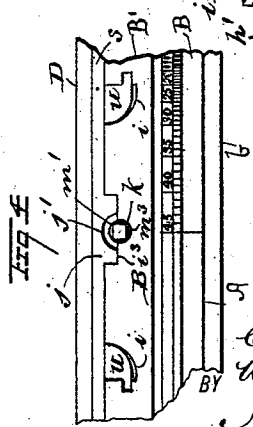
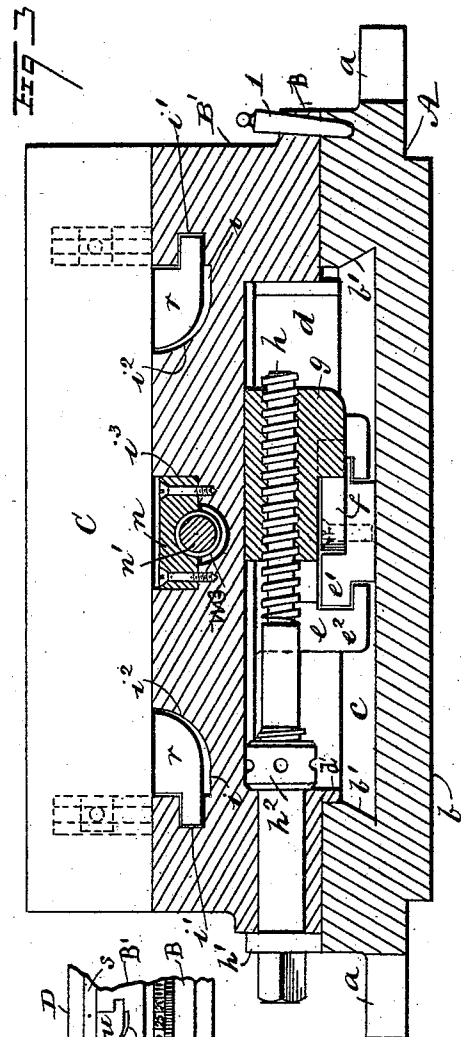
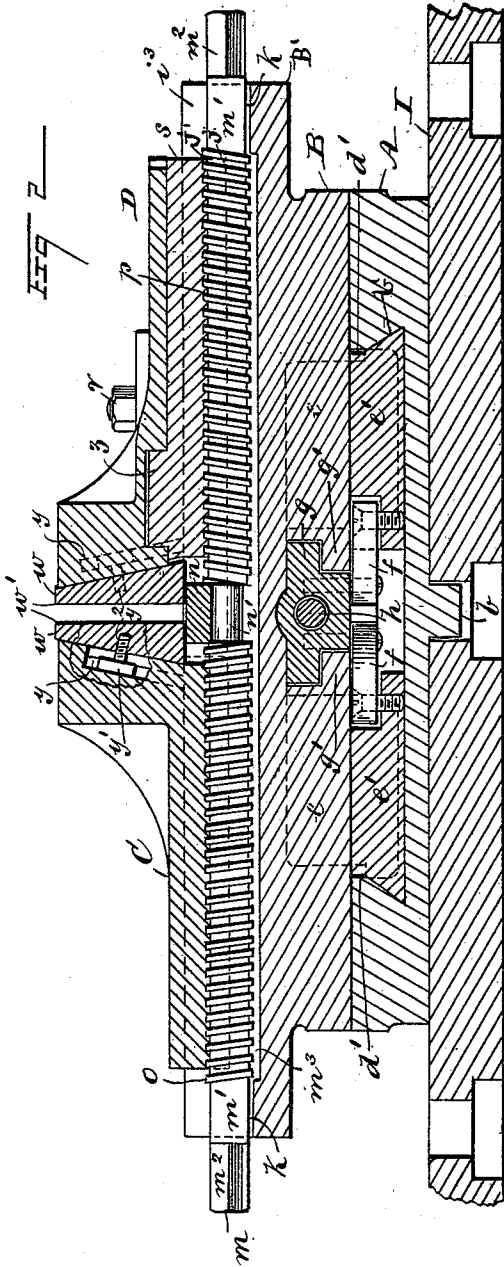

WITNESSES:  
*H. Walker*  
*C. Sedgwick*

INVENTOR:  
*C. F. Fulmer*  
*W. E. Kelvie*  
 BY *Munn & Co*  
 ATTORNEYS

(No Model.)

3 Sheets—Sheet 3.

# C. F. FULMER & W. E. KELVIE. PLANER CHUCK.

No. 455,196.

Patented June 30, 1891.

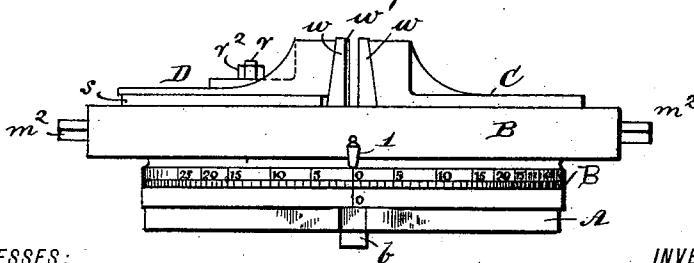
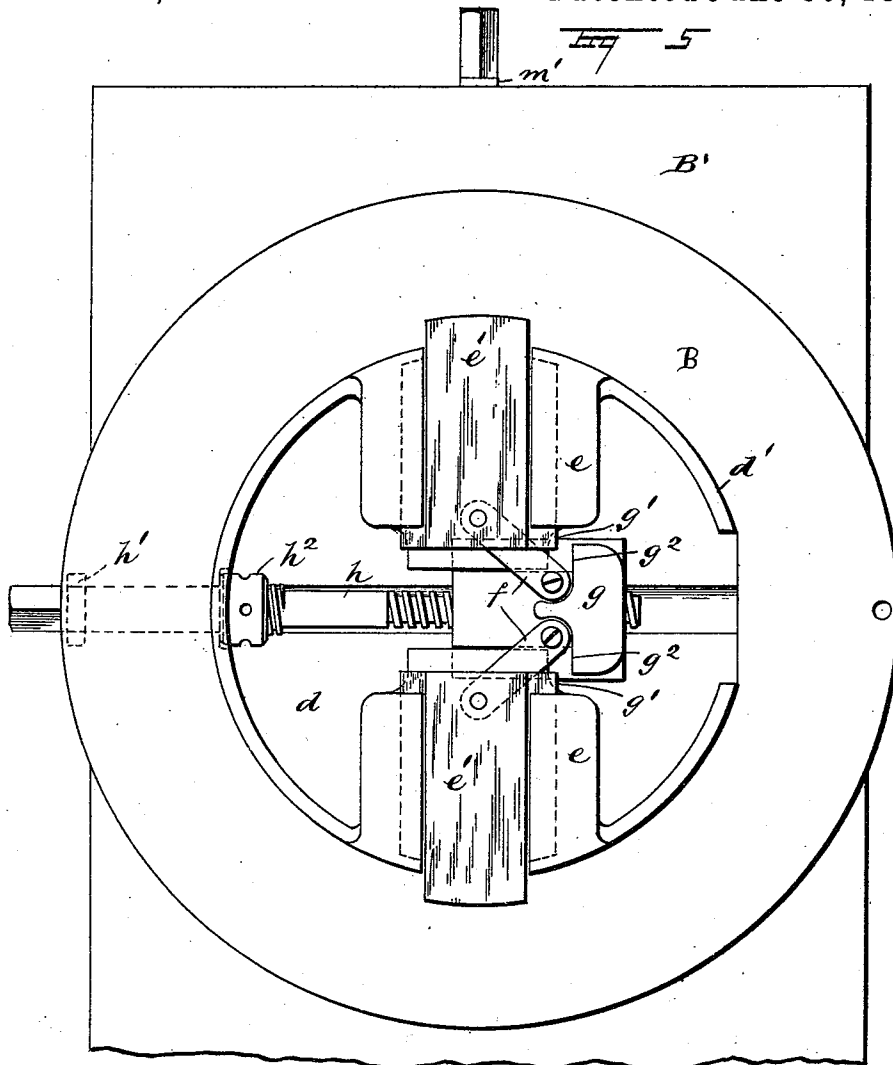

WITNESSES:  
*H. Walker*  
*L. Sedgwick*

Fig 6

INVENTOR:  
*C. F. Fulmer*  
 BY *W. E. Kelvie*  
*Munn & Co.*  
 ATTORNEYS

# UNITED STATES PATENT OFFICE.

CHARLES F. FULMER AND WILLIAM E. KELVIE, OF PLAINFIELD, NEW JERSEY.

## PLANER-CHUCK.

SPECIFICATION forming part of Letters Patent No. 455,196, dated June 30, 1891.

Application filed January 20, 1891. Serial No. 378,446. (No model.)

To all whom it may concern:

Be it known that we, CHARLES F. FULMER and WILLIAM E. KELVIE, both of Plainfield, in the county of Union and State of New Jersey, have invented a new and useful Planer-Chuck, of which the following is a full, clear, and exact description.

This invention relates to improvements in removable chucks for planing-machines, shapers, and similar metal-working tools, and has for its objects to provide a novel, simple, and convenient device of the character indicated, which will afford means for a quick change of adjustment to suit the form of material to be held, either straight or taper in shape, and that will securely retain such material in position to be operated upon by the cutting-tool of the planer.

To these ends our invention consists in certain features of construction and combinations of parts, as is hereinafter described and claimed.

Reference is to be had to the accompanying drawings, forming a part of this specification, in which similar letters of reference indicate corresponding parts in all the views.

Figure 1 is a plan view of the device. Fig. 2 is a longitudinal section of the chuck, taken on the line 2 2 in Fig. 1, in position upon a planer-bed shown broken. Fig. 3 is a transverse section taken on the line 3 3 in Fig. 1. Fig. 4 is a broken side elevation opposite the arrow 4 in Fig. 1. Fig. 5 is a reverse plan view of the upper main section of the chuck, and Fig. 6 is a side elevation of the chuck opposite the arrow 6 in Fig. 1.

The base-piece A of the chuck is preferably made circular in contour, and of a suitable diameter for its use as a support for other parts located upon it. Two ears *a* are formed on the periphery of the base-piece A, at opposite points, which ears are open-slotted in alignment with a central depending tongue *b*, formed on the lower surface of the base-piece to enter a slot in the planer-bed plate I, said ears affording means to secure the chuck upon the bed-plate for service by the employment of screw-bolts in an obvious manner.

The base-piece A is provided in its top with a central circular recess *c* of a proper depth,

(see Fig. 3,) which recess has the lower portion of its edge wall *b'*, which is concentric with the periphery of the base-piece, undercut so as to provide means for the locking-contact of other parts to be described.

The chuck-section B is rectangular in form in its upper portion B', and of greater thickness than the base-piece A, and has its lower portion, equal to about one-half of the thickness of the entire chuck-section, made circular to correspond in shape and diameter with the circular face of the base-piece whereon it is imposed. A central recess *d* is formed in the body of the chuck-section B, from the lower face upwardly, which recess *d* is mainly circular in outline, and a depending circular flange *d'* extends from the section B around said recess, which flange fits neatly within the recess *c* of the base-piece A, so as to retain the upper section in removable connection with said lower section and prevent a lateral displacement thereof. At each side of the recess *d* a block *e*, integral with the section B, projects from said recess into the recess *c* of the base A, the ends of which blocks within the recess *d* are undercut to form slideways *g'* for a rectangular nut *g*, and those portions of the blocks *e* extending within the recess *c* are provided with undercut channels *e'*, forming slideways for the radial locking-dogs *e'*. The inner ends of the dogs *e'* are connected with the nut *g* by the links *f*, pivoted to the dogs and the nut. As shown in Fig. 5, the nut *g* has opposite shoulders *g'* formed on it, which engage the links *f* when the nut is moved to project the dogs and limit the movement of the parts when the dogs are fully projected. The nut *g* is longitudinally bored and threaded to receive the adjusting-screw *h*, which extends to the periphery of the chuck-section and is journaled therein, as represented in Figs. 3 and 5, there being a fixed collar *h'* and an adjustable collar *h''* provided to retain the screw and take up looseness endwise, while free rotatable movement is permitted. The outer extremities of the locking-dogs *e'* are beveled and curved to correspond with the pitch and degree of curvature of the undercut-wall *b'* of the recess *c* in the base A, so that the radial projection by a proper rotatable move-

ment of the adjusting-screw  $h$  of the dogs will secure the section B upon the base-piece A at any point of rotatable adjustment of the upper section of the chuck.

5 In order to distinguish parts readily, the upper portion B' of the chuck-section B is termed a "platen," as it serves the purposes of such a member of a chuck in the support of work held thereon, and has its upper surface made parallel with the bottom face of the base-piece A. Two grooves  $i$  are longitudinally formed in the platen B' from its top face downwardly, which grooves are located near opposite side edges of the section, and each groove is undercut, as at  $i'$ , on the side wall which is nearest to the edge of the platen B', the inner walls of the grooves  $i$  being curved, as indicated in Fig. 3 at  $i^2$ . Centrally of face of the platen B' is a rectangular groove  $i^3$ , parallel with the grooves  $i'$ , and centrally of the groove  $i^3$  is formed a semicircular groove  $m^3$ . At the end of the groove  $m^3$  half-boxes  $k$  are formed or inserted securely for the reception of the journal ends  $m'$  of the jaw-screw  $m$ , which is extended throughout the length of the platen and is provided with squared projecting ends  $m^2$  for the engagement of a wrench when the screw is to be rotated. The jaw-actuating screw  $m$  is located below the top surface of the platen portion B' in the groove  $m^3$ , and is centrally supported by the engagement of a longitudinally-central journal  $n'$  thereon with a reduced portion of the groove, which is provided with a removable cap  $n$ . From the shoulders produced near the longitudinal center of the screw  $m$  by formation of the journal  $n'$  the oppositely-pitched screw-threads  $o$  extend to the outer journals  $m'$ .

40 On the platen B' two jaws C D are mounted, which are each provided with a rectangular tongue  $j$ , adapted to fit snugly in the groove  $i^3$  of the platen, which tongues are each provided centrally of their under face with a semicircular groove  $j'$ , which is threaded to form a half-nut to fit over the corresponding thread of the screw  $m$  when the jaws are in position on the platen.

The jaw C is furnished with depending and laterally-extended tongues  $r$ , which are located and shaped to slide freely in the grooves  $i$  of the platen B', as indicated in Fig. 3, which tongues serve to retain the jaw from vertical displacement and permit its sliding movement when the screw  $m$  is manipulated. The other jaw D is composed of two pieces, one resting upon the other. The lower or base piece  $s$  is a flat and comparatively thin plate having the tongue  $j$  and half-nut  $j'$  on its lower surface to engage the screw  $m$ . The base-plate  $s$  is further provided with tongues  $u$ , which enter and slide in the grooves  $i$ , that are shaped to fit them, and thus retain said base-plate in position on the platen portion B', the tongues  $r$  and  $u$  of both jaws extending across their under surfaces to insure such a result. Upon the base-piece  $s$  the jaw

D proper is placed and thereto secured by the standing bolts  $v$ , which project vertically at proper points on the jaw-base to pass through the curved slots  $v'$ , that are formed in the jaw.

Each of the jaws C D is preferably furnished with a removable grip-piece  $w$ , of similar formation, and, as will be seen in Fig. 2, the faces of the jaws engaged by said pieces are sloped to incline their upper edges toward each other. Grooves  $y$  are produced in the inclined faces of the jaws C D, which grooves are undercut to receive and retain the heads  $y'$  of the studs  $y^2$ , which project from the adjacent surfaces of the grip-pieces  $w$ , which studs when slid into place from below will retain the grip-pieces and jaws connected together. Each grip-piece  $w$  is sloped on the face which engages the jaw-wall it is secured upon, their lower edges being parallel with the platen-face, and their adjacent faces  $w'$ , formed at right angles with the lower edges, are thus located in parallel vertical planes and adapted to bite upon a piece of material placed between them, clamping the same securely if the screw  $m$  is turned in the proper direction. Owing to this slope given to the engaged surfaces of the grip-pieces  $w$  and jaws C D the first-named pieces are forced by a wedging action to rest upon the platen portion B', which engages with material placed between them.

The inner edge of the base-piece  $s$  of jaw D is cut away from its longitudinal center toward each end, as shown in dotted lines in Fig. 1, so that a limited vibratory movement of the jaw on the base  $s$  will be permitted when the nuts  $v^2$  of the standing bolts  $v$  are slackened, and to facilitate this vibratory movement of the jaw, so as to adjust it to suit tapered sides on material to be gripped between the jaws, there is a circular boss  $z$  formed on or secured to the upper surface of the base-piece, which enters a socket in the lower face of the jaw D and forms a pivot on which the jaw can swing.

In use, the chuck being placed upon the bed-plate of a planer or shaping-machine, and thereto secured, as before mentioned, the work placed in the jaws C D may be planed true on the exposed surface. If the jaws of the chuck are required to be retained parallel with the guides of the planer-bed whereon the chuck is affixed, this is effected by inserting the pin  $l$  in aligned perforations made for its reception in the projecting edge of the section B and in the base-piece A at a zero-point. From the point where the pin  $l$  is to be introduced, as just stated, there are graduations marked upon the edge of the section B, which will enable the operator to set the jaws of the chuck at any degree of lateral deviation from the zero-point, which adjustment is effected after the locking-dogs are released, and when these are projected by a manipulation of the screw  $h$  the section B will be retained at any point of rotatable adjustment desired.

Having thus described our invention, we claim as new and desire to secure by Letters Patent—

1. In a planer-chuck, the combination, with  
5 a base-piece having a circular recess in its upper face, the wall of which is undercut, and a platen having a depending flange that enters the recess of the base, is recessed within the flange, and provided with depending  
10 blocks having slideways formed longitudinally therein and in their opposing faces, of a nut-block held to slide between the depending blocks, locking-dogs having a beveled end and held to slide in the said blocks,  
15 links connecting the dogs and nut-block, and a screw held to turn in the platen and engaging the nut-block, substantially as set forth.
2. In a planer-chuck, the combination, with  
20 a platen rotatably mounted and securable on a base-piece and grooved to receive tongues on sliding jaws, of a sliding jaw having two transverse tongues on its lower face and provided with a transverse half-nut that engages an actuating-screw, a sliding jaw composed of a base-plate having tongues and a  
25 half-nut on its lower face, and a jaw swivel-mounted and securable on the base-plate, substantially as set forth.
3. In a planer-chuck, the combination, with  
30 a base-piece A and a platen portion B' on an upper chuck-piece B, rotatable and securable on the base-piece having a longitudinal groove in its upper surface, of two jaws retained movably on the platen portion, one  
35 jaw being adapted to swivel, and each jaw provided with a depending tongue that is formed as a half-nut, which nuts have their

threads oppositely pitched, a screw extending the entire length of the platen portion B', having a rotatable bearing at its longitudinal center on said platen portion, and oppositely-pitched threads which respectively engage the half-nuts of the jaws and adapted at each end for rotation by a wrench, substantially as described.

4. In a planer-chuck, the combination, with  
45 two movable chuck-jaws, one adapted to swivel on a center, of a vertically-insertible and removable grip-piece for each chuck-jaw, which grip-pieces are wedge-shaped in cross-section, smallest at the upper edge and have  
50 an interlocking bolted connection with the jaws, which latter incline on their faces so as to permit said grip-pieces to present vertical faces toward each other, substantially as described.

5. In a planer-chuck, the combination, with  
55 a rotatable platen securable on a base-piece, of a jaw having tongues that slide in grooves of the platen and which is actuated by a screw, and another jaw composed of a base-plate having tongues that engage the platen-grooves, a circular boss and two standing bolts, and a jaw-piece having a socket in its lower face to fit on the boss of the base-plate  
60 and provided with curved slots through which the standing bolts pass, substantially as set forth.

CHARLES F. FULMER.  
WILLIAM E. KELVIE.

Witnesses:

SAMUEL A. CLAUSTON,  
EDWARD G. POPE.