



(86) Date de dépôt PCT/PCT Filing Date: 2000/02/10
(87) Date publication PCT/PCT Publication Date: 2000/08/17
(85) Entrée phase nationale/National Entry: 2001/08/10
(86) N° demande PCT/PCT Application No.: US 00/03667
(87) N° publication PCT/PCT Publication No.: WO 00/47197
(30) Priorité/Priority: 1999/02/12 (60/119,951) US

(51) Cl.Int.⁷/Int.Cl.⁷ A61K 31/195, A61K 31/57, A61K 31/335,
A61K 31/275, A61K 31/255, A61P 35/00, A61P 9/00,
A61K 31/19, A61K 31/175, A61K 31/165, A61K 45/06
(71) Demandeur/Applicant:
QUANAM MEDICAL CORPORATION, US
(72) Inventeurs/Inventors:
FROIX, MICHAEL, US;
POMERANTSEVA, IRINA D., US;
EURY, ROBERT, US;
ALVARADO, ANGELICA, US
(74) Agent: OSLER, HOSKIN & HARCOURT LLP

(54) Titre : AGENTS D'ALKYLATION DESTINES AU TRAITEMENT DE PROLIFERATION CELLULAIRE
(54) Title: ALKYLATING AGENTS FOR TREATMENT OF CELLULAR PROLIFERATION

(57) Abrégé/Abstract:

A method of inhibiting cellular proliferation associated with a hyperproliferative condition, such as restenosis, is described. The method includes administering an alkylating agent. A stent for local administration of the alkylating agent is also described.

(12) INTERNATIONAL APPLICATION PUBLISHED UNDER THE PATENT COOPERATION TREATY (PCT)

(19) World Intellectual Property Organization
International Bureau



(43) International Publication Date
17 August 2000 (17.08.2000)

PCT

(10) International Publication Number
WO 00/47197 A3

- (51) International Patent Classification⁷: **A61K 31/195**, 31/19, 31/175, 31/255, 45/06, 31/335, 31/165, 31/275, 31/57, A61P 9/00, 35/00
- (74) Agents: **MOHR, Judy, M.** et al.; Dehlinger & Associates, P.O. Box 60850, Palo Alto, CA 94306-0850 (US).
- (21) International Application Number: PCT/US00/03667
- (81) Designated States (*national*): AE, AL, AM, AT, AU, AZ, BA, BB, BG, BR, BY, CA, CH, CN, CR, CU, CZ, DE, DK, DM, EE, ES, FI, GB, GD, GE, GH, GM, HR, HU, ID, IL, IN, IS, JP, KE, KG, KP, KR, KZ, LC, LK, LR, LS, LT, LU, LV, MA, MD, MG, MK, MN, MW, MX, NO, NZ, PL, PT, RO, RU, SD, SE, SG, SI, SK, SL, TJ, TM, TR, TT, TZ, UA, UG, UZ, VN, YU, ZA, ZW.
- (22) International Filing Date: 10 February 2000 (10.02.2000)
- (25) Filing Language: English
- (26) Publication Language: English
- (84) Designated States (*regional*): ARIPO patent (GH, GM, KE, LS, MW, SD, SL, SZ, TZ, UG, ZW), Eurasian patent (AM, AZ, BY, KG, KZ, MD, RU, TJ, TM), European patent (AT, BE, CH, CY, DE, DK, ES, FI, FR, GB, GR, IE, IT, LU, MC, NL, PT, SE), OAPI patent (BF, BJ, CF, CG, CI, CM, GA, GN, GW, ML, MR, NE, SN, TD, TG).
- (30) Priority Data:
60/119,951 12 February 1999 (12.02.1999) US
- (71) Applicant: **QUANAM MEDICAL CORPORATION** [US/US]; 2255F- Martin Avenue, Santa Clara, CA 95050 (US).
- Published:**
— *With international search report.*
- (72) Inventors: **ALVARADO, Angelica**; 750 Pomeroy Avenue, Santa Clara, CA 95051 (US). **EURY, Robert**; 10387-B Lockwood Drive, Cupertino, CA 95014 (US). **POMERANTSEVA, Irina, D.**; 820 Bay Street, Mountain View, CA 94041 (US). **FROIX, Michael**; 3433 Woodstock Lane, Mountain View, CA 94040 (US).
- (88) Date of publication of the international search report:
5 April 2001
- For two-letter codes and other abbreviations, refer to the "Guidance Notes on Codes and Abbreviations" appearing at the beginning of each regular issue of the PCT Gazette.*

(54) Title: ALKYLATING AGENTS FOR TREATMENT OF CELLULAR PROLIFERATION

(57) Abstract: A method of inhibiting cellular proliferation associated with a hyperproliferative condition, such as restenosis, is described. The method includes administering an alkylating agent. A stent for local administration of the alkylating agent is also described.

WO 00/47197 A3

ALKYLATING AGENTS FOR TREATMENT OF CELLULAR PROLIFERATION**Field of the Invention**

5 The present invention relates to a method of inhibiting cellular proliferation in a subject.

Background of the Invention

 Vascular disease is a leading cause of death and disability in westernized societies. Atherosclerosis is one of the more common forms of vascular disease and leads to insufficient blood supply to critical body organs resulting in heart attack, stroke and kidney failure. Atherosclerosis also causes complications in people suffering from hypertension and diabetes.

 Atherosclerosis has been described as a form of vascular injury. A normal vessel wall consists of three reasonably well-defined layers: the intima, the media and the adventitia. The intima lines the lumen of all arteries and is composed of a single continuous layer of endothelial cells. The media consists of only one cell type, the smooth muscle cell, arranged in either a single layer or multiple lamellae. These cells are surrounded by small amounts of collagen and elastic fibers. The outermost layer of the artery is the adventitia, which consists of a loose interwoven admixture of collagen bundles, elastic fibers, smooth muscle cells and fibroblasts (Harrison's PRINCIPLES OF INTERNAL MEDICINE, 12th Edition, McGraw-Hill, Inc., 1991, Chapter 195).

 While the processes causing atherosclerosis are complex and not completely understood, an underlying pathology to the numerous theories for the cause of atherosclerosis is the abnormal migration and proliferation of medial-smooth muscle cells into the intima (Harrison). The proliferation of the smooth muscle cells in the intima ultimately blocks blood flow and makes vessels abnormally susceptible to local blood clotting.

 A similar pathology is also implicated in restenosis, the so-called recurrence of stenosis or artery stricture after corrective surgery. In fact, restenosis has been described as an accelerated atherosclerosis induced by injury (Forrester, J.S., *et al.*, *JACC*, 17(3):758-769 (1991)). Restenosis results from vascular smooth muscle cell proliferation, migration and neo-intimal accumulation, due to incompletely understood processes

involving regulatory molecules, such as platelet derived growth factor (Ferns, G.A, *et al.*, *Science*, 253:1129 (1991)).

Restenosis has been observed to occur after coronary artery bypass surgery, heart transplantation, atherectomy, laser ablation and balloon angioplasty. In particular, restenosis is common after balloon angioplasty, also referred to as percutaneous transluminal coronary angioplasty, which is widely used as a treatment modality in patients with coronary artery disease to reduce lumen obstruction and improve coronary blood flow. It is estimated that between 25-35% of patients develop restenosis within 1-3 months after balloon coronary angioplasty, necessitating further interventions such as repeat angioplasty or coronary bypass surgery.

Therapies to reduce restenosis have focused on administration of chemotherapeutic agents which either interfere with formation of thrombosis or suppress smooth muscle cell proliferation. Anti-coagulants for suppression of thrombosis include heparin, warfarin, low molecular weight heparin and hirudin (Lovqvist, A., *et al.*, *J. Int. Medicine*, 233:215-116 (1993)). Agents for inhibiting the proliferation of smooth muscle cells include glucocorticoids, angiotensin converting enzyme inhibitors, colchicine, vincristine, actinomycin, low molecular weight heparin, platelet derived growth factor and others (Lovqvist, A., *et al.*). More recently, paclitaxel (TAXOL[®]) has been suggested for use in preventing restenosis (U.S. Patent Nos. 5,616,608; 5,733,925; 5,716,981).

Despite the number of compounds tested for treatment and/or prevention of restenosis, there remains a need for an effective therapy.

Summary of the Invention

Accordingly, it is an object of the invention to provide a method for inhibiting cellular proliferation associated with restenosis and atherosclerosis.

In one aspect, the invention includes a method of inhibiting cellular proliferation associated with a hyperproliferative condition in a subject by administering to the subject a therapeutically effective amount of an alkylating agent.

In one embodiment, the alkylating agent is selected from the group consisting of nitrogen mustards, ethylenimines, alkyl sulfonates, nitrosoureas and triazenes.

In another embodiment, the hyperproliferative condition to be treated with the alkylating agent is restenosis.

The alkylating agent, in one embodiment, is delivered locally, for example via a drug

delivery catheter, a guidewire or a stent.

In one preferred embodiment, the stent is a polymer stent loaded with a alkylating agent, such as nitrogen mustards, ethylenimines, alkyl sulfonates, nitrosoureas and triazenes.

5 In another embodiment, the stent is a metal stent and the alkylating agent is incorporated into a polymer sheath carried on the metal stent. For example, in one embodiment, the stent is coated with a synthetic polymer or a biopolymer carrying the alkylating agent. In an alternative embodiment, the alkylating agent is incorporated into indentations formed on the metal stent.

10 In yet another embodiment, the method for inhibiting cellular proliferation further comprises coadministering a second therapeutic agent. The second therapeutic agent is, in one embodiment, a microtubule stabilizing agent, such as paclitaxel, derivatives of paclitaxel, colchicine, verapamil and dexamethasone. In another embodiment, the second therapeutic agent is radiation treatment.

15 In another aspect, the invention includes a method of inhibiting restenosis in a patient by administering to the patient, an effective amount of an alkylating agent.

In still another aspect, the invention includes a device for treatment of restenosis, comprising a stent carrying a therapeutically effective amount of an alkylating agent.

20 These and other objects and features of the invention will be more fully appreciated when the following detailed description of the invention is read in conjunction with the accompanying drawings.

Brief Description of the Drawings

25 Figs. 1A-1C are illustrations of the basic V-shaped stent used in studies in support of the present invention, where the stent is shown unwound (Fig. 1A), wound to a small diameter for insertion in a vessel (Fig. 1B) and in an open, expanded diameter after placement in a vessel (Fig. 1C);

Fig. 2A shows a stent suitable for carrying a polymer member or coating containing a water-insoluble paclitaxel derivative; and

30 Figs. 2B-2C show stents composed of a metal support stent coaxially carrying a polymer sleeve (Fig. 2B) or members (Fig. 2C).

Detailed Description of the Invention

I. Definitions

"Hyperproliferative condition" refers to undesirable cell growth associated with atherosclerosis, restenosis, proliferative vitreoretinopathy and psoriasis. The term is not intended to include cellular hyperproliferation associated with cancerous conditions.

"Undesirable cell growth" or "inhibiting undesirable cell growth" refers to unregulated cell division associated with smooth muscle cells or fibroblasts and to the inhibition of such growth.

"Alkylating agent" refers to any compound that has the property of becoming a strong electrophile through the formation of carbonium ion intermediates or of transition complexes with a target molecule. These reactions result in the formation of covalent linkages by alkylation of various nucleophilic moieties such as phosphate, amino, sulfhydryl, hydroxyl, carboxyl and imidazole groups. Exemplary agents are given below.

"Administering" as referred to herein is intended to include routes of administration which allow the alkylating agent to perform its intended function of inhibiting undesirable cell growth. Such administering includes systemic and local or site specific administration by an appropriate route, such as injection (subcutaneous, intravenous, parenteral, intraperitoneal, intrathecal, etc.) oral, inhalation, transdermal, administration by means of a drug delivery catheter, or implantation of a drug-carrying device.

"Effective amount" refers to the amount necessary or sufficient to inhibit the undesirable cell growth, *e.g.*, prevent the undesirable cell growth or reduce the existing cell growth. The effective amount can vary depending on factors known to those of skill in the art, such as the type of cell growth, the mode and regimen of administration, the size of the subject, the severity of the cell growth, etc. One of skill in the art would be able to consider such factors and make the determination regarding the effective amount.

"Pharmaceutically acceptable carrier" refers to any substance coadministered with the alkylating agent which allows the compound to perform its intended function. Examples of such carriers include solutions, solvents, dispersion media, delay agents, emulsions, microparticles and the like.

II. Method of Treatment

In the method of the invention, an alkylating agent is administered to a subject at risk of developing or suffering from a hyperproliferative condition. The alkylating agent is

administered in a therapeutically effective amount by a selected route as will be described. There are five major types of alkylating agents: nitrogen mustards, ethylenimines, alkyl sulfonates, nitrosoureas and triazenes. The pharmacologic activity and cytotoxicity effects of the alkylating agents are related to the alkylation of its target molecule, DNA. The agents become strong electrophiles through the formation of carbonium ion intermediates or of transition complexes with the target molecule. These reactions result in the formation of covalent linkages by alkylation of various nucleophilic moieties such as phosphate, amino, sulfhydryl, hydroxyl, carboxyl and imidazole groups. For example the 7-nitrogen atom of guanine is particularly susceptible to the formation of a covalent bond with both monofunctional and bifunctional alkylating agents. Other atoms in the purine and pyrimidine bases of DNA, for example, the 1 and 3 nitrogens of adenine, the 3 nitrogen of cytosine and the 6 oxygen of guanine also may be alkylated to a lesser degree, as are the phosphate atoms of the DNA chains and the proteins associated with DNA.

The nitrogen mustards include mechlorethamine, cyclophosphamide, ifosfamide, melphalan and chlorambucil. These compounds are nitrogen analogs of sulfur mustard and the biological activity is based upon the presence of the bis-(2-chloroethyl) grouping. Mechlorethamine is very reactive, whereas melphalan and chlorambucil, due the aromatic ring, are more stable derivatives of mechlorethamine. In studies performed in support of the invention, to be described below, melphalan was administered *in vivo* to test animals for treatment of restenosis.

The ethyleneimines and methylmelamines include the compounds triethylenemelamine, thiotepa (triethylene thiophosphoramidate) and altretamine (hexamethylmelamine). Thiotepa and its primary metabolite, triethylenephosphoramidate, are capable of forming DNA cross-links, as the aziridine rings open after protonation of the ring-nitrogen, leading to a reactive molecule.

The alkyl sulfonates include busulfan. The nitrosoureas include carmustine and lomustine, semustine and streptozocin. The triazenes include dacarbazine.

The effects of alkylating drugs are not cell cycle-specific, and the drugs act on cells at any stage in the cell cycle. Toxicity is usually expressed when the cell enters the S phase and progression through the cell cycle is blocked. While not cell cycle-specific, quantitative differences may be detected when nitrogen mustards are applied to synchronized cells at different phases of the cycle. Cells appear more sensitive in late G1 or S than in G2 or mitosis, or early G1. Polynucleotides are more susceptible to alkylation

in the unpaired state than in the helical form, during replication of DNA portions of the molecule are unpaired.

Accordingly, in one embodiment of the invention, an alkylating agent is administered to a subject suffering from or at risk of developing a hyperproliferative condition, such as those discussed above. The alkylating agent is administered at a dosage according to the condition to be treated and to the method of administration, as can be determined by those of skill in the art.

In one embodiment, the alkylating agent is administered in combination with a second therapeutic compound selected from paclitaxel, and derivatives of paclitaxel; topoisomerase inhibitors, such as camptothecin; calcium channel blockers, such as verapamil; and steroidal non-inflammatory agents, such as dexamethasone. When the second therapeutic agent is a calcium channel blocker, it serves to reduce elimination of the first therapeutic agent from the cells. When the second therapeutic agent is an anti-inflammatory agent, it is effective to reduce inflammation at a site of injury.

The therapeutic compounds described above are used in the method of the invention for inhibiting the growth of vascular smooth muscle cells in the vessel. "Inhibiting" as used herein is intended to include reducing, delaying or eliminating undesirable cell growth. With respect to the embodiment of the invention where the undesirable cell growth is associated with restenosis following balloon coronary angioplasty, "reducing" means decreasing the intimal thickening that results from smooth muscle cell proliferation following angioplasty, either in an animal model or in humans. "Delaying" means delaying the time until onset of visible intimal hyperplasia, as observed histologically or by angiographic techniques, following angioplasty. "Eliminating" refers to completely reducing and/or completely delaying intimal hyperplasia in a subject such that sufficient blood flow in the vessel is established and surgical intervention is not necessary.

The alkylating agents are administered in accordance with the invention by any route which provides effective therapy for the inhibition of restenosis. Such routes include but are not limited to systemic administration of the drug by injection, including bolus, pulsed and continuous administration injected intravenously, subcutaneously, intramuscularly, intraperitoneally, etc. Continuous or delayed release formulations are also contemplated, both for systemic administration and local or site specific administration.

One preferred mode of administering the alkylating agent is via a drug delivery catheter, such as those described in U.S. Patent Nos. 5,558,642, 5,295,962, 5,171,217 and

5,674,192. Typically, such catheters have a flexible shaft and an inflatable balloon at the distal end of the shaft. The catheter is inserted into a vessel in an un-inflated condition and the balloon is positioned at the site to be treated with the alkylating agent. The balloon member is inflated and apertures in the balloon assembly provide drug carried in the catheter to be delivered to the target site. The drug can be carried in solution form, entrapped in microparticles of a physiologically compatible polymer or incorporated into a polymer, such as a hydrogel, which is coated on the balloon region for rapid release of the drug during expansion of the balloon. Catheters such as these provide a convenient way to administer the drug in conjunction with a balloon angioplasty procedure.

In other embodiments, the alkylating agent is administered to the target site by an infusion catheter or by a drug delivery guidewire. An infusion catheter provides delivery of agents to a target site by placing the tip of the catheter at the site and connecting the catheter to a pump. The tip of the catheter generally includes openings through which the agent is pumped at a desired rate to the target site (U.S. Patent No. 5,720,720). A drug delivery guidewire has been described in U.S. Patent No. 5,569,197, where the guidewire is hollow and has an opening at its distal end for infusion of a drug therethrough.

In a preferred embodiment, the alkylating agent is administered locally to the site of undesired cell growth in the form of an implanted medical device, such as a stent. Endovascular stents for use following balloon angioplasty are known in the art and described in, for example, U.S. Patent Nos. 5,395,390 (Simon), 4,739,762 (Palmaz), 5,195,984 (Schatz) and 5,163,952 (Froix).

In one embodiment, the stent is a metal stent. Exemplary biocompatible and nontoxic metals for stents include nickel-titanium alloys, tantalum, and steel. In this embodiment, the alkylating agent can be adsorbed onto the stent or incorporated into indentations, *i.e.*, pockets, grooves or pits, formed on the surface of the stent. In another embodiment, the metal stent is coated with a polymer-drug solution containing the selected alkylating agent or drug combination by dipping the stent in the solution or spraying the stent with the solution.

The metal stent, in other embodiments, is adapted to carry a polymer member, where the metal stent serves as a structural support for the polymer member carrying the alkylating agent. For example, a polymer-based, drug-containing fiber can be threaded through the stent apertures. The metal stent provides the mechanical support in the vessel after deployment for maintaining vessel patency, and the polymer thread provides a

controlled release of the alkylating agent. Another example is to provide a drug-loaded polymer sheath for encompassing the stent, as described in U.S. Patent No. 5,383,928 (Scott, *et al.*). Another example is to provide a polymer stent which coexpands with the metal stent when placed in the target vessel, as described in U.S. Patent No. 5,674,242 (Phan, *et al.*).

In another embodiment, the stent is formed of a biocompatible polymer, including hydrogels, polyurethanes, polyethylenes, ethylenevinyl acetate copolymers, and the like. One preferred class of polymers are shape-memory polymers, as described for example by Froix, U.S. Patent No. 5,163,952, which is incorporated by reference herein. Stents formed of shape-memory polymers, which include methacrylate-containing and acrylate-containing polymers, readily expand to assume a memory condition to expand and press against the lumen walls of a target vessel, as described by Phan, *et al.*, U.S. Patent No. 5,603,722, which is incorporated by reference in its entirety.

In studies in support of the present invention, the alkylating agent melphalan was incorporated into polymer stents and implanted into pig coronary arteries, and this study will now be discussed.

The polymer stent used in the studies in support of the invention is illustrated in Figs. 1A-1C. Stent 10 is composed of a unitary strip 12 having two legs 14, 16. The stent typically includes a radio-opaque material, such as gold, stainless steel, platinum, tantalum or metal salts, to provide a means of identifying by x-ray or other imaging technique the location of the stent during and after stent placement. Stent 10 in Fig. 1A includes bands of gold 18, 20 for imaging purposes. The radio-opaque material is incorporated into the stent prior to formation of the polymer or is applied as a coating after formation of the stent.

Fig. 1B shows stent 10 placed in a closed condition for insertion and placement in a target vessel. To place the stent in its small diameter, closed condition, the stent is wound around a cylinder or rod sized according to the diameter of the target vessel. For example, the stent of Fig. 1A can be wrapped around the balloon portion of a balloon catheter and secured thereon by a variety of means, including restraining devices, adhesives or, in the case of memory polymers, by the self-restraining nature of the material. Stent 10 is wound into its closed condition by wrapping legs 14, 16 in the same direction or in opposite directions.

After placement of the stent in a target vessel, the stent is expanded by a stimulus, such as pressure from the balloon portion of the catheter or heat. The leg portions of the

stent expand radially until their movement is constrained by the walls of the vessel.

Example 1 describes preparation of a polymer stent as depicted in Figs. 1A-1C, where the stent is composed of a methacrylate-based polymer.

Another exemplary stent is shown in Figs. 3A-3C. In this embodiment, a support
5 stent, composed of metal or polymer, carries a drug-loaded polymer sleeve or sheath about its outer circumference. Fig. 3A shows an exemplary support stent 20, composed of a biocompatible metal, such as stainless steel, in an expanded, large diameter condition. The stent is composed of unit cells, such as unit cells 22, 24, 26, joined in a radial
10 direction to form a plurality of unit cells 28. Support stent 20 as shown is composed of four pluralities of unit cells, 28, 30, 32 and 34. The pluralities of unit cells are joined radially by a connecting segment, such as connecting segment 36 which joins pluralities 32, 34. Each unit cell is expandable to move the stent from a small-diameter condition, for insertion into a body lumen, to a large-diameter condition, for deployment into the
15 body lumen. The stent of Fig. 3A is described in detail in co-owned PCT application no. WO 99/49811, which is herein incorporated by reference.

Fig. 3B shows the metal stent of Fig. 3A with a continuous polymer sheath 40 encasing the metal support stent. The outer polymer sleeve is prepared, for example, as set forth in Example 2, and contains the agent or agents to be administered. The sleeve is carried coaxially about the outer circumference of the support stent and takes the form
20 of a flat sheet rolled into a cylindrical or tubular shape by overlapping the edges 42, 44 of the sheet. It will be appreciated that the initial configuration of the tubular member is not limited to a flat sheet, but can also be prepared from an extruded tube-form.

Fig. 3C depicts another embodiment of the metal stent of Fig. 3A carrying about its outer surface a polymer member. More specifically, the polymer member in the
25 embodiment of Fig. 3C is composed of 4 short polymer segments 41, 42, 44, 46, each of which carries the drug or drugs to be administered. A stent according to the embodiment of Fig. 3C has better flexibility and tractability than the embodiment of Fig. 3B.

In studies performed in support of the invention, stents as depicted in Fig. 3C were prepared and loaded with melphalan and then placed in the coronary arteries of pigs.
30 Preparation of the melphalan-loaded stents is described in Example 3. The stents, which carried a total drug load of 546 μg , were deployed into the pig coronary artery using a balloon catheter and positioned distally in the right coronary artery and approximately in the middle of the left circumflex artery. As a control, a commercially available metal stent

not carrying a polymer member was also deployed into the left anterior descending artery.

At the time of insertion of the test and control stents, the coronary arteries were characterized using a computer-based coronary angiography analysis system (Umans, V.A., *et al.*, *JACC*, 21(6):1382-1390 (1993)). Boundaries of a selected coronary artery segment were detected automatically from optically magnified and video-digitized regions of interest. The catheter used for insertion of the stents was used as a scaling device to determine the dimensions of the artery at the site of implantation. The original vessel diameter at the time of implantation was determined.

After the one month test period, the arteries were then explanted from the pig and pressure fixed for morphometric analysis. The lumen diameters of the vessels after the treatment period were found by determining the smallest lumen diameter in the region of stent placement. The percent stenosis was taken as one minus the stented vessel's minimum lumen diameter divided by the diameter of an unstented reference vessel times one-hundred. The balloon to artery ratio was also determined as a measure of the degree of distension of the vessel by the balloon. The results are shown in Table 1.

Table 1

Stent Configuration	Stent Location	Vessel Diameter Pre-stent (mm)	Vessel Diameter Post-Stent (mm)	Balloon to Artery Ratio	% Diameter Stenosis
metal support/ polymer segments with melphalan	right coronary artery (distal)	2.76	3.02	1.09	22
metal support/ polymer segments with melphalan	left circumflex artery (mid)	2.64	2.71	1.03	27
metal support stent	left anterior descending (mid)	2.42	2.95	1.22	50

As can be seen from the data in Table 1, arteries treated with stents containing melphalan had a lower percent diameter stenosis when compared to the metal stent, indicating that melphalan is effective to inhibit the undesirable cell growth associated with vessel injury during coronary angioplasty and stent insertion.

The loading level of drug into the stent can be selected and tailored according to the desired treatment regimen. The loading is readily varied, as will be appreciated by one of skill in the art, by varying the loading solvent, the drug concentration and the polymer composition of the stent. Typically loading levels are between 0.01-50% drug on a weight

basis. This feature of the invention is further illustrated in Examples 4-6 which describe preparation of stents carrying the alkylating agents chlorambucil, carmustine and busulfan.

In another embodiment of the invention, a second therapeutic agent is administered along with the alkylating agent. The second therapeutic agent, in one embodiment is radiation, and in another embodiment, is a therapeutic agent which is incorporated into the stent or is administered by another route, such as a systemic or local route of administration described above. Exemplary compounds for use as the second therapeutic agent include paclitaxel, derivatives of paclitaxel including water soluble and non-water soluble derivatives, verapamil, colchicine and dexamethasone.

10

III. Examples

The following examples illustrate a method of administering an alkylating agent to a subject, in accordance with the present invention. The examples are in no way intended to limit the scope of the invention.

15

A. Materials

Melphalan, chlorambucil, carmustine and busulfan were purchased from Sigma Chemical Co (St. Louis, MO). All solvents were reagent grade.

20

B. Methods

Late loss was calculated by subtracting the inner diameter of the stent from the measured minimal lumen diameter of the vessel after the one-month treatment period with a stent. Percentage stenosis was taken as the late loss divided by the original vessel diameter x 100.

25

EXAMPLE 1

Polymer Stent Preparation

A polymer stent was prepared according to the procedure described in U.S. Patent No. 5,674,242 (Phan, *et al.*). Briefly, the materials in Table 2 were mixed together in the specified amounts, purged with nitrogen, and then polymerized between glass plates to form thin films having a thickness of approximately 0.14 mm. Prior to polymerization, gold strips were placed at intervals to provide for radio-opacity of the stents.

30

Table 2

Material	wt%
polyethyleneglycol (1000) methacrylate (NOF Corp.)	32.8
methylmethacrylate (Aldrich)	46.8
butyl methacrylate (Rhom Tech Inc)	14.0
hexanedioldimethacrylate (Aldrich)	5.6
Darocur 1173 (Ciba-Geigy) or azobisisobutylnitrile (AIBN, Aldrich)	0.8

After polymerization, the film was cut into V-shaped strips (Fig. 1) using a punch and any
 5 unpolymerized monomer was removed by solvent extraction.

The selected drug was loaded into the polymer stent by preparing a solution of the
 drug in a suitable solvent, typically an alcohol (isopropanol or methanol), n-
 methylpyrrolidone or dimethylformamide. The stent was weighed and placed in a clean
 container. A known volume of the drug solution was pipetted over the surface of the stent.

10 The stent was then placed in a vacuum oven at about 40 °C for between 1-3 days to dry.

Example 2

Polymer Sleeve Preparation

The following mixture of monomers was weighed into a suitable container: 60.1%
 15 butyl acrylate (Aldrich Chemical, St. Paul MN); 30% polyethylene oxide monomethyl
 ether monomethacrylate (MW 1000 daltons)(NOF Corp., Tokyo Japan); and 9.8%
 methylmethacrylate (Aldrich Chemical). 0.05% of hexane diol dimethacrylate (Aldrich
 Chemical), a cross-linker, and 0.10% of Darocur® 1173 (E. Merck, Darmstadt, Germany),
 a photoinitiator, were added to initiate polymerization. The monomers were mixed
 20 together, purged with nitrogen and then polymerized between glass plates to form thin films
 having a thickness of approximately 0.14 mm. The film was cut into the desired size for
 formation of polymer sleeve segments placed about a metal support stent, as depicted in
 Fig. 3C.

Example 3

In vivo Testing of Polymer Stent Containing Melphalan

Stents carrying four polymer sleeve segments (see Fig. 3C) were prepared as described in Example 2.

5 A solution of melphalan in methanol was prepared by dissolving 0.0293 g melphalan in 1.5 mL methanol to give a solution concentration of 19.5 $\mu\text{g}/\mu\text{L}$. Each of the four segments was loaded with 136.5 μg of melphalan from the stock solution by pipetting 1 μL of the solution on each segment 7 times. The total drug loading in the polymer stent was 546 μg .

10 Two drug-loaded stents and a control metal stents with no polymer sleeve were placed into the coronary arteries of healthy Domestic Farm Swine pigs (Pork Power, Inc.) by conventional techniques using a commercially available catheter (Advanced Cardiovascular Systems). The stents were imaged during and after the insertion procedure to ensure proper placement using conventional angiographic imaging techniques. The
15 metal control stent was placed in the left anterior descending artery and the polymer/metal stents carrying the drug were placed in the right coronary artery and in the left circumflex artery.

One month after placement of the stents, the pig was euthanized and the heart and coronary arteries explanted. The arteries were pressure fixed for morphometric analysis to
20 determine the percent diameter stenosis and percent intimal growth. The percent diameter stenosis was taken as $1 - [(\text{stented vessel's minimum lumenal diameter}) / (\text{diameter of unstented reference vessel})] * 100$. The percent intimal growth was taken as $1 - [(\text{stented vessel's minimum lumenal diameter}) / (\text{diameter of stented portion prior to stent placement})] * 100$. The balloon to artery ratio was also determined as a measure of the
25 degree of distension of the vessel by the balloon. The results are shown in Table 1.

Example 4

Preparation of a Stent Containing Chlorambucil

A stent carrying four polymer sleeve segments (see Fig. 3C) was prepared as
30 described in Example 2.

A solution of chlorambucil in dimethylformamide was prepared by dissolving 0.0115 g chlorambucil in 60 μL dimethylformamide to give a solution concentration of 192 $\mu\text{g}/\mu\text{L}$. Each of the four segments was loaded with 384 μg of chlorambucil from the

stock solution by pipetting 1 μL of the solution on each segment 2 times. The total drug loading in the polymer stent was 768 μg .

Example 5

5 **Preparation of a Stent Containing Carmustine**

A stent carrying four polymer sleeve segments (see Fig. 3C) was prepared as described in Example 2.

A solution of carmustine in dimethylformamide was prepared by dissolving 0.0058 g carmustine in 30 μL dimethylformamide to give a solution concentration of 193 $\mu\text{g}/\mu\text{L}$.

10 Each of the four segments was loaded with 386 μg of carmustine from the stock solution by pipetting 1 μL of the solution on each segment 2 times. The total drug loading in the polymer stent was 772 μg .

Example 6

15 **Preparation of a Stent Containing Busulfan**

A stent carrying four polymer sleeve segments (see Fig. 3C) was prepared as described in Example 2.

A solution of busulfan in dimethylsulfoxide was prepared by dissolving 0.0243 g busulfan in 300 μL dimethylsulfoxide to give a solution concentration of 81 $\mu\text{g}/\mu\text{L}$. Each
20 of the four segments was loaded with 81 μg of busulfan from the stock solution by pipetting 1 μL of the solution on each segment. The total drug loading in the polymer stent was 162 μg .

Although the invention has been described with respect to particular embodiments, it will be apparent to those skilled in the art that various changes and modifications can
25 be made without departing from the invention.

IT IS CLAIMED:

1. A composition comprising a therapeutically effective amount of an alkylating agent for use in inhibiting cellular proliferation associated with a hyperproliferative condition in a subject.

2. The composition according to claim 1, wherein the alkylating agent is selected from the groups consisting of nitrogen mustards, ethylenimines, alkyl sulfonates, nitrosoureas and triazenes.

3. The composition according to claim 1 or claim 2, wherein the hyperproliferative condition is restenosis.

4. The composition according to any one of claims 1-3, wherein the alkylating agent is administered locally by means of a drug delivery catheter, a guidewire or a stent.

5. The a composition according to any one of claims 1-3, wherein the alkylating agent is administered locally by means of a stent which is a polymer stent loaded with the alkylating agent.

6. The composition according to any one of claims 1-3, wherein the alkylating agent is administered locally by means of a stent which is a metal stent and the alkylating agent is incorporated into a polymer sheath carried on the metal stent.

7. The composition according to any one of claims 1-3, wherein the alkylating agent is administered locally by means of a stent coated with a synthetic polymer or a biopolymer carrying the alkylating agent.

8. The composition according to any one of claims 1-3, wherein the alkylating agent is administered locally by means of a stent which is a metal stent and the alkylating agent is incorporated into indentations formed on the stent.

9. The composition according to any one of the preceding claims further including a second therapeutic agent administered in combination with the alkylating agent.

10. The composition according to claim 9, wherein said second therapeutic agent is a
5 microtubule stabilizing agent.

11. The composition according to claim 10, wherein said microtubule stabilizing agent is selected from the group consisting of paclitaxel, derivatives of paclitaxel, colchicine, verapamil and dexamethasone.
10

12. The composition according to claim 9, wherein said second therapeutic agent is radiation treatment.

13. A composition comprising a therapeutically effective amount of an alkylating
15 agent for use in inhibiting restenosis.

14. The composition according to claim 13, wherein the alkylating agent is selected from the groups consisting of nitrogen mustards, ethylenimines, alkyl sulfonates, nitrosoureas and triazenes.
20

15. The composition according to claim 13 or claim 14, wherein the hyperproliferative condition is restenosis.

16. The composition according to any one of claims 13-15, wherein the alkylating
25 agent is administered locally by means of a drug delivery catheter, a guidewire or a stent.

17. The composition according to any one of claims 13-15, wherein the alkylating agent is administered locally by means of a stent which is a polymer stent loaded with the alkylating agent.
30

18. The composition according to any one of claims 13-15, wherein the alkylating agent is administered locally by means of a stent which is a metal stent and the alkylating agent is incorporated into a polymer sheath carried on the metal stent.

19. The composition according to any one of claims 13-15, wherein the alkylating agent is administered locally by means of a stent coated with a synthetic polymer or a biopolymer carrying the alkylating agent.

5 20. The composition according to any one of claims 13-15, wherein the alkylating agent is administered locally by means of a stent which is a metal stent and the alkylating agent is incorporated into indentations formed on the stent.

10 21. The composition according to any one of claims 13-20 further including a second therapeutic agent administered in combination with the alkylating agent.

22. The composition according to claim 21, wherein said second therapeutic agent is a microtubule stabilizing agent.

15 23. The composition according to claim 22, wherein said microtubule stabilizing agent is selected from the group consisting of paclitaxel, derivatives of paclitaxel, colchicine, verapamil and dexamethasone.

20 24. The composition according to claim 21, wherein said second therapeutic agent is radiation treatment.

25. A stent for use with the composition according to any one of claims 13-24.

25 26. Use of a composition comprising a therapeutically effective amount of an alkylating agent for the manufacture of a medicament for use in inhibiting restenosis.

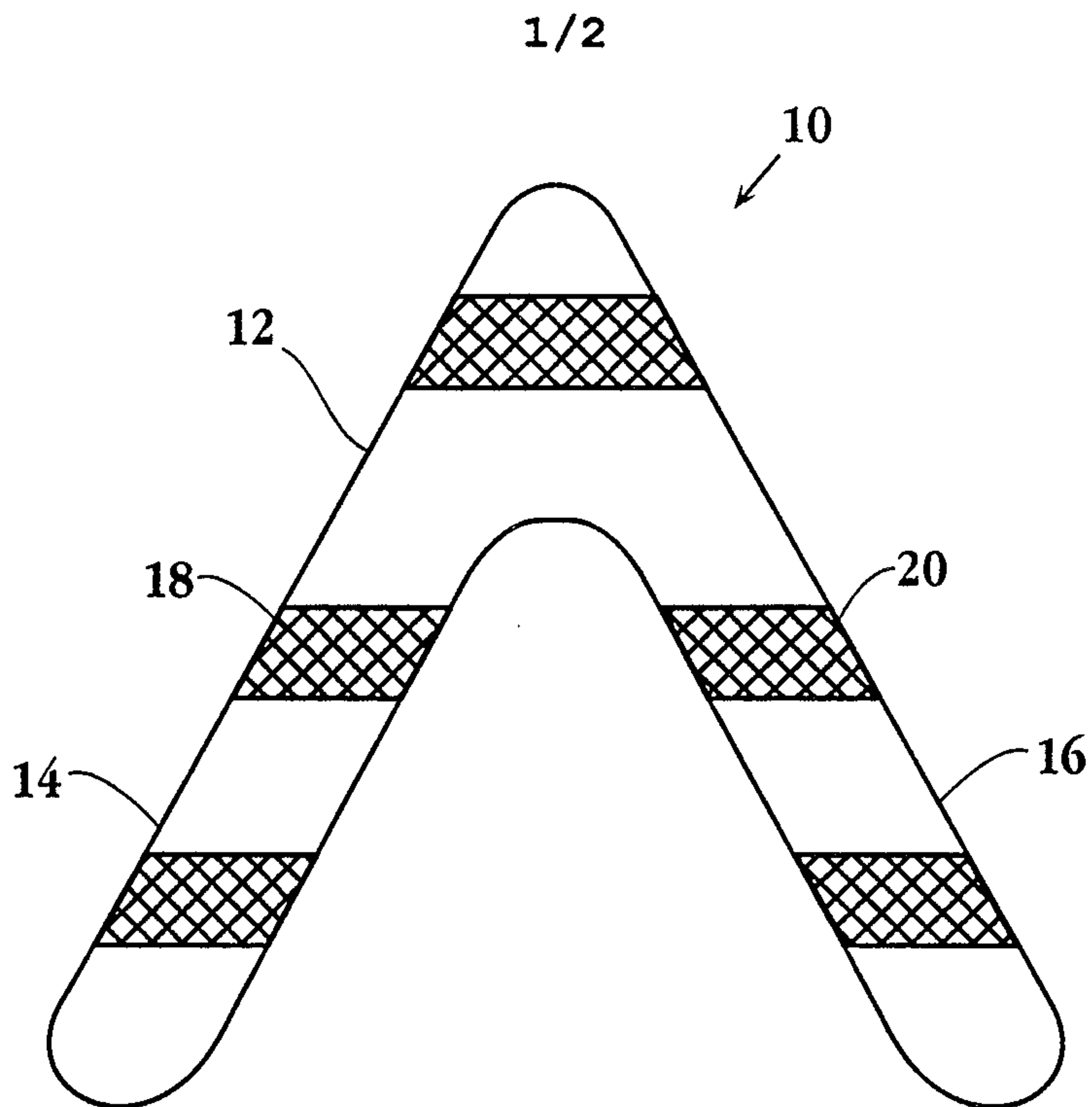

Fig. 1A

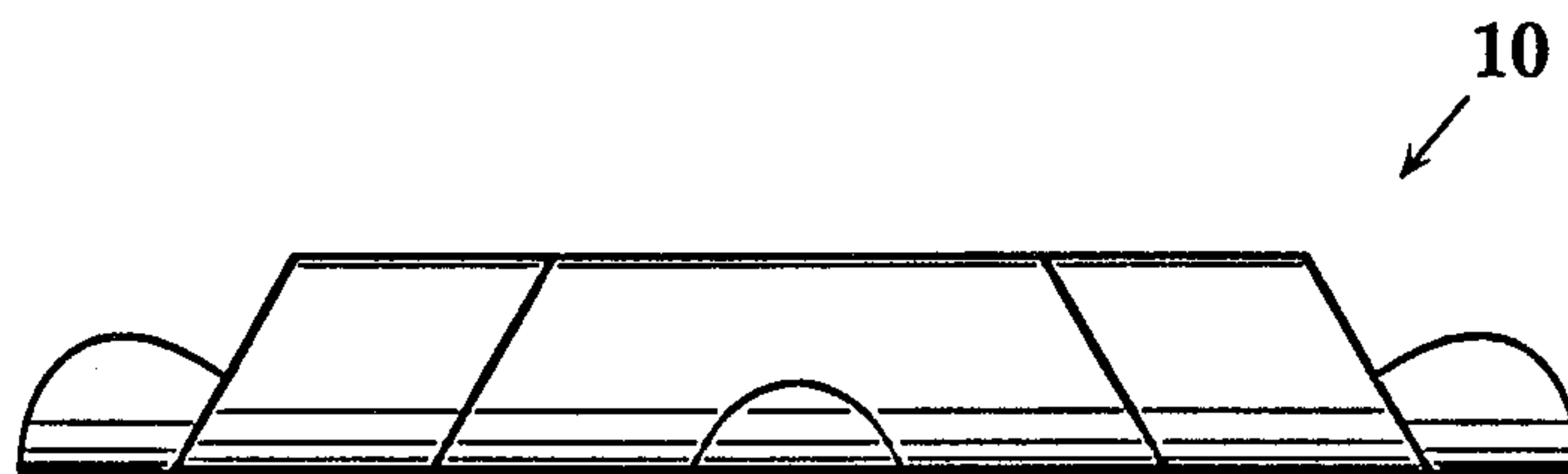

Fig. 1B

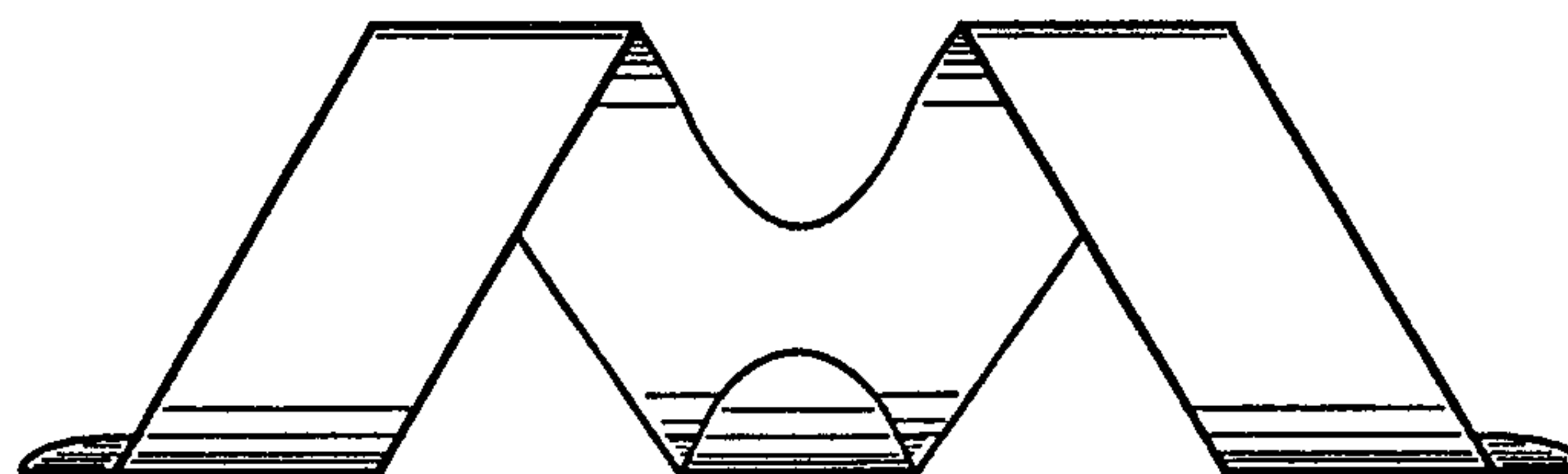

Fig. 1C

2/2

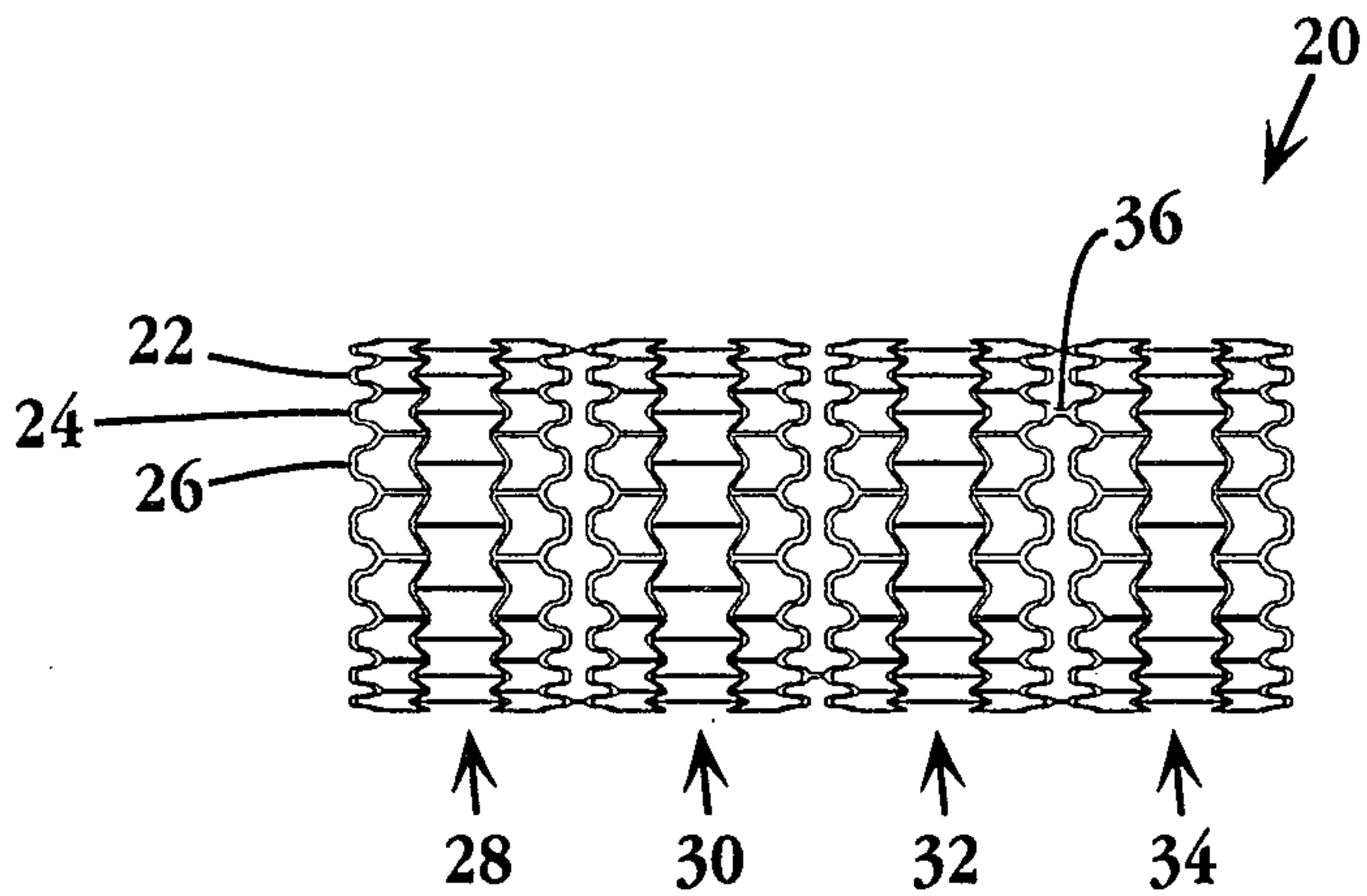

Fig. 2A

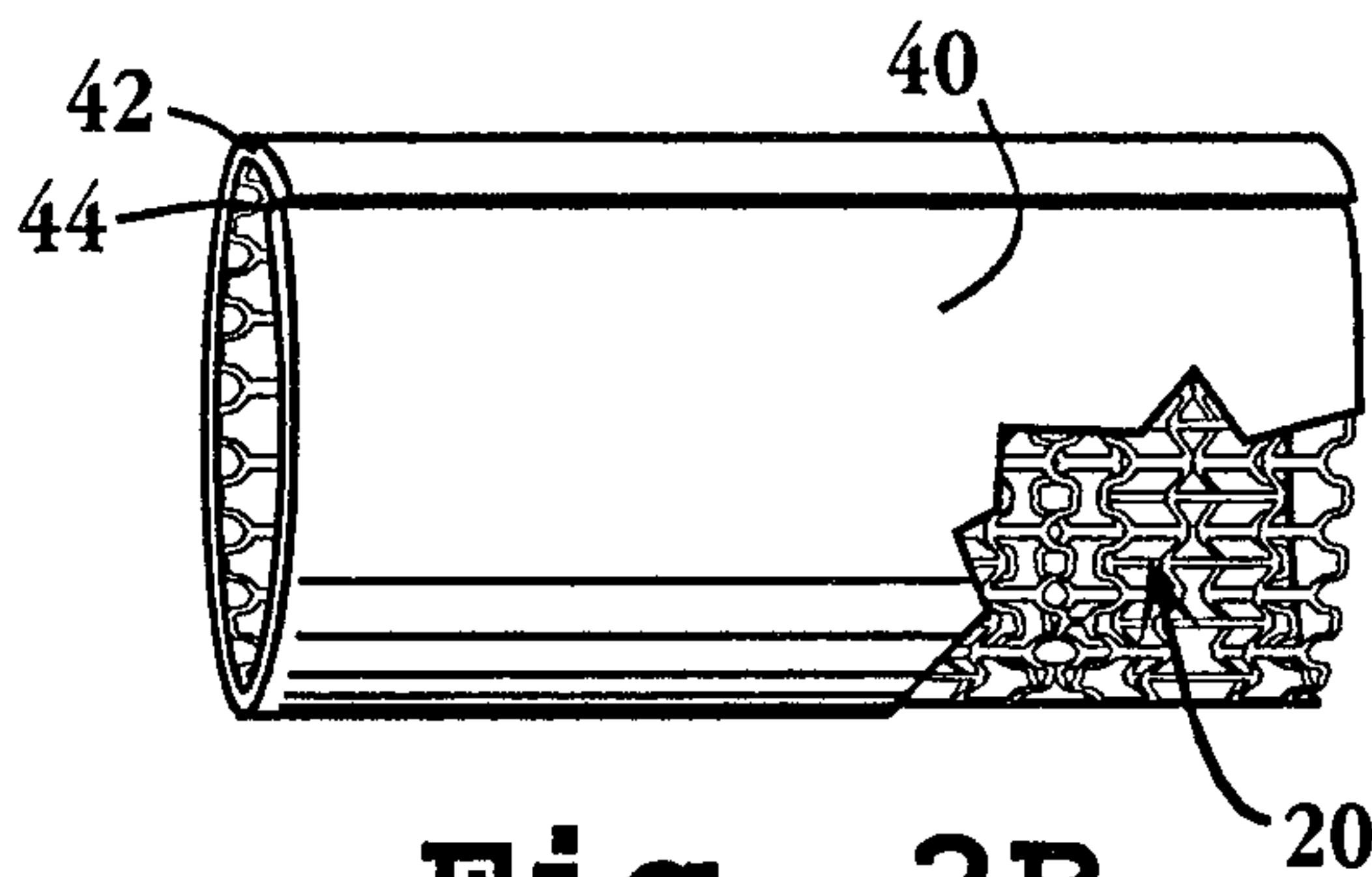

Fig. 2B

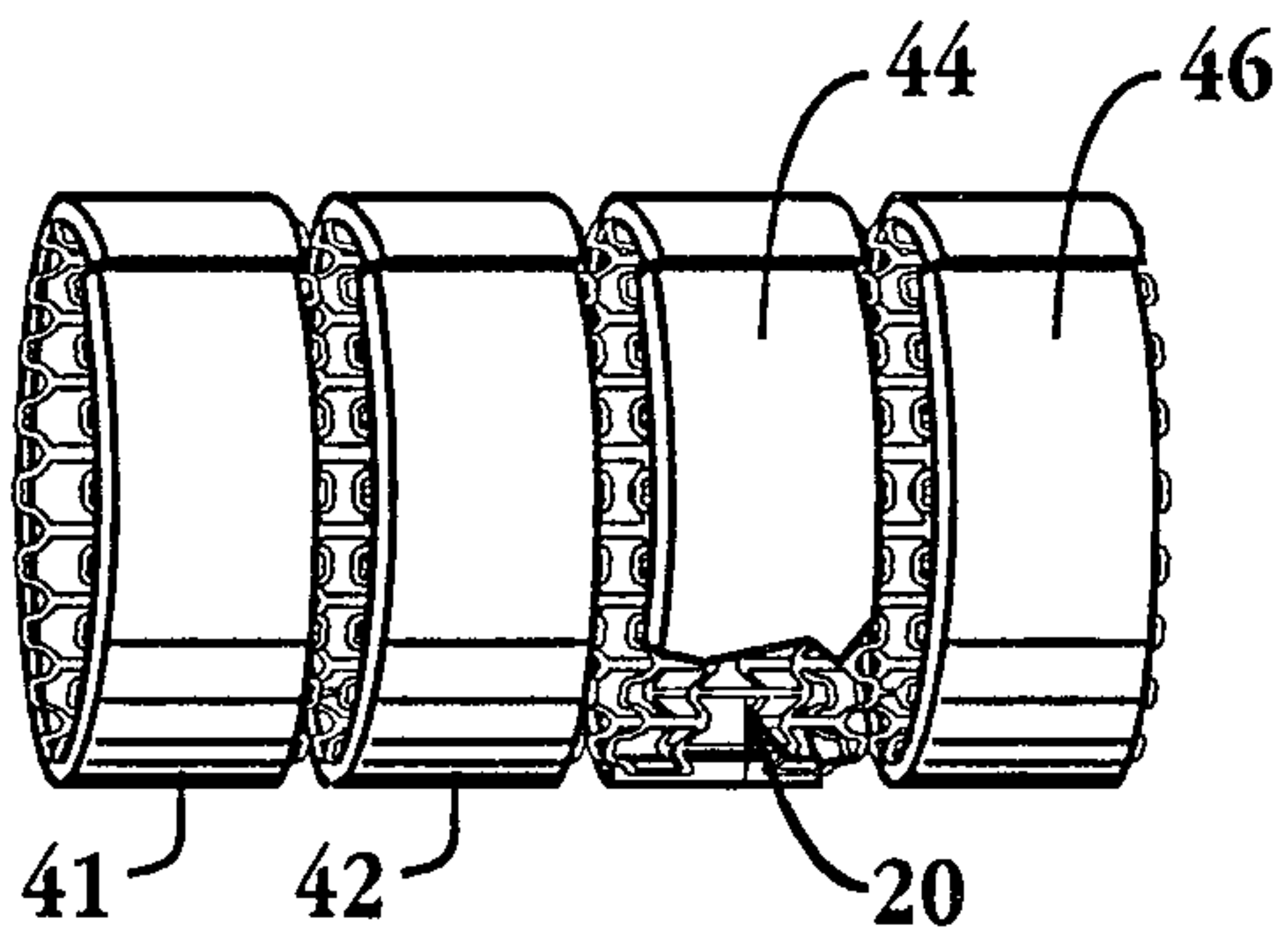

Fig. 2C