

(21) Application No: 2304086.8

(22) Date of Filing: 21.03.2023

(71) Applicant(s):
Carl Hitchenson
Heyswood Lodge, Heyes Park, Hartford,
Northwich CW8 2AJ, Cheshire, United Kingdom

(72) Inventor(s):
Carl Hitchenson

(74) Agent and/or Address for Service:
Hutchinson IP Ltd
57 Hoghton Street, SOUTHPORT, Merseyside,
PR9 0PG, United Kingdom

(51) INT CL:
E04G 21/18 (2006.01)

(56) Documents Cited:
GB 2220435 A GB 2134580 A
US 4431331 A1 US 3603628 A
US 1457964 A US 20150078815 A1
US 20060059856 A1

(58) Field of Search:
INT CL E04G, F16L
Other: WPI, EPODOC

(54) Title of the Invention: **Building profile extensions**
Abstract Title: **Building profile extensions used for aligning bricks or blocks when constructing a building**

(57) A building profile is extended by connecting two tubular building profiles (12, 14 figure 1) end to end using a connector 100. A main body 102 part of the connector has a length 104, a width 106 and a depth 108 designed to slidingly fit inside opposing ends of the tubular building profiles. The building profiles are held in axial alignment by adjacent side faces 110, 112 of the main body of the connector each being provided with at least two resilient projections 114 that extend substantially perpendicularly from the side faces. The resilient projections are configured to engage respective opposing internal walls of the tubular building profiles thereby urging an edge of the connector body into engagement with an internal corner of the tubular building profiles. The resilient projections may be captive, spring loaded balls, one of which may optionally self-centre and engage with an aperture (116 figure 5) of one of the tubular building profiles.

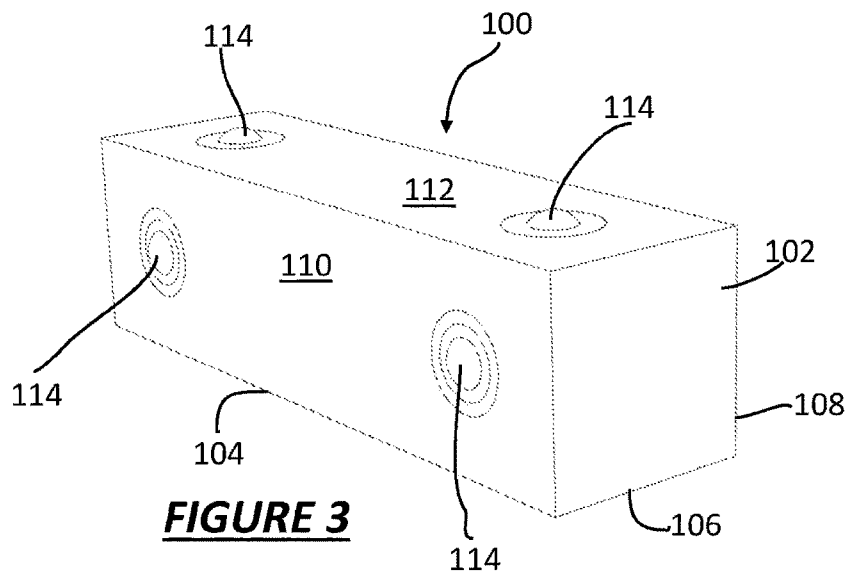

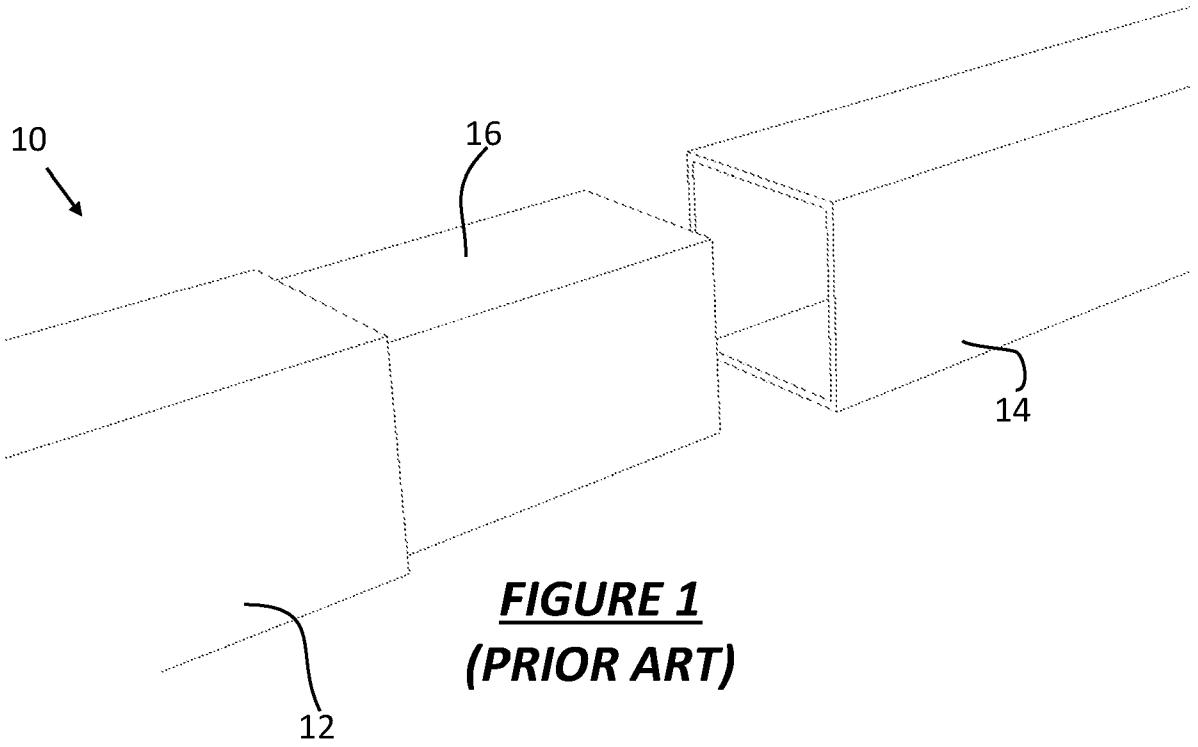

FIGURE 1
(PRIOR ART)

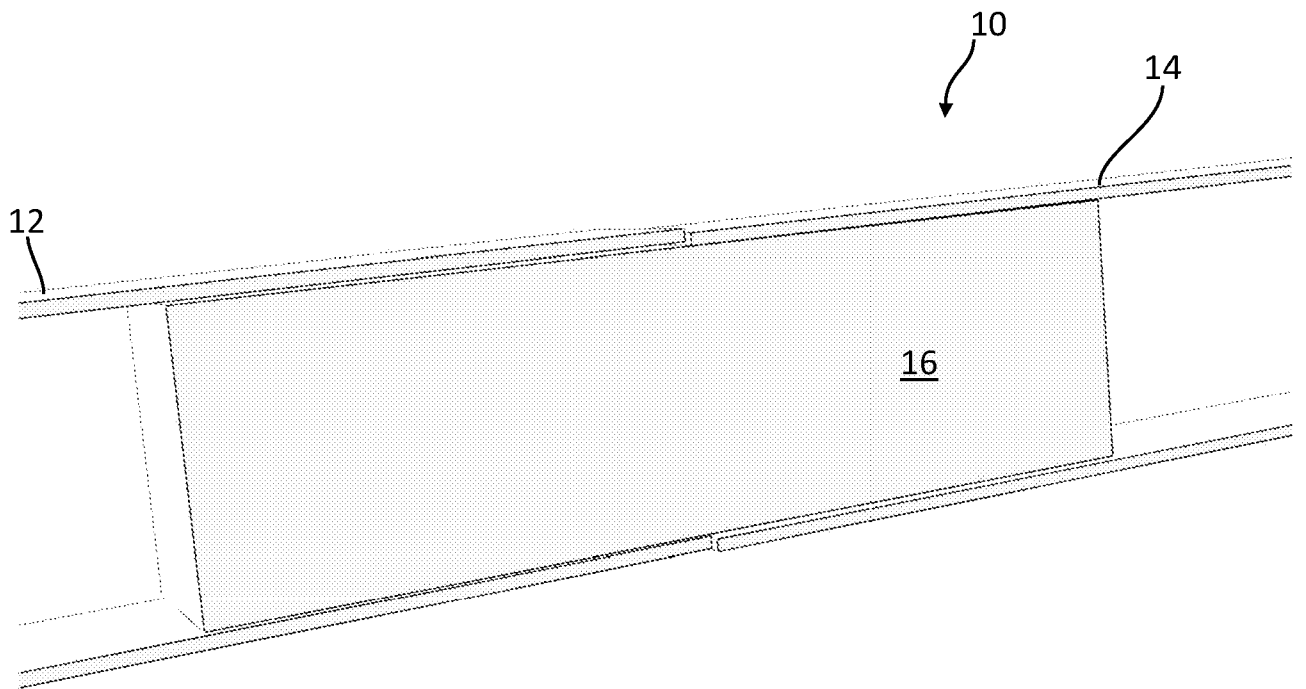

FIGURE 2
(PRIOR ART)

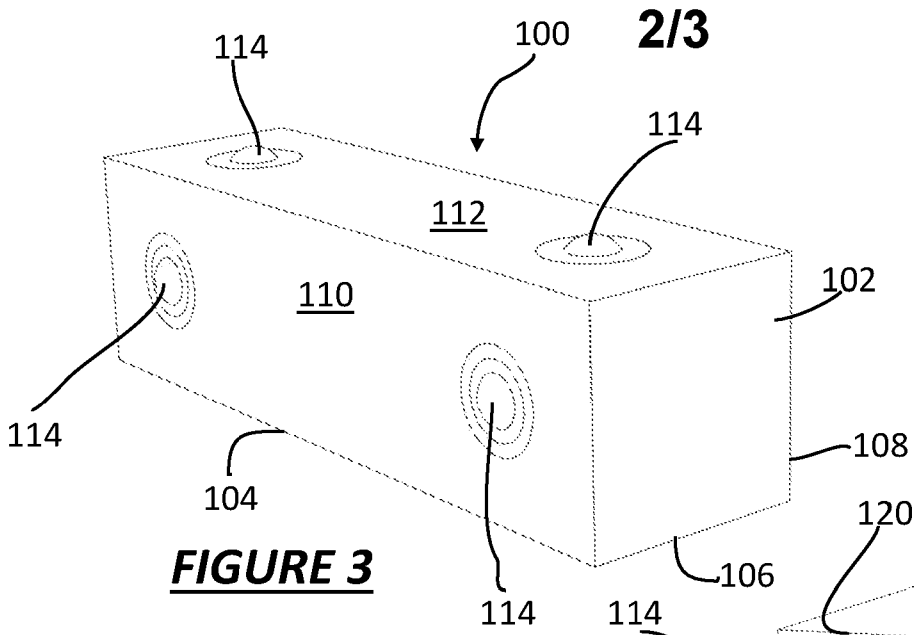

FIGURE 3

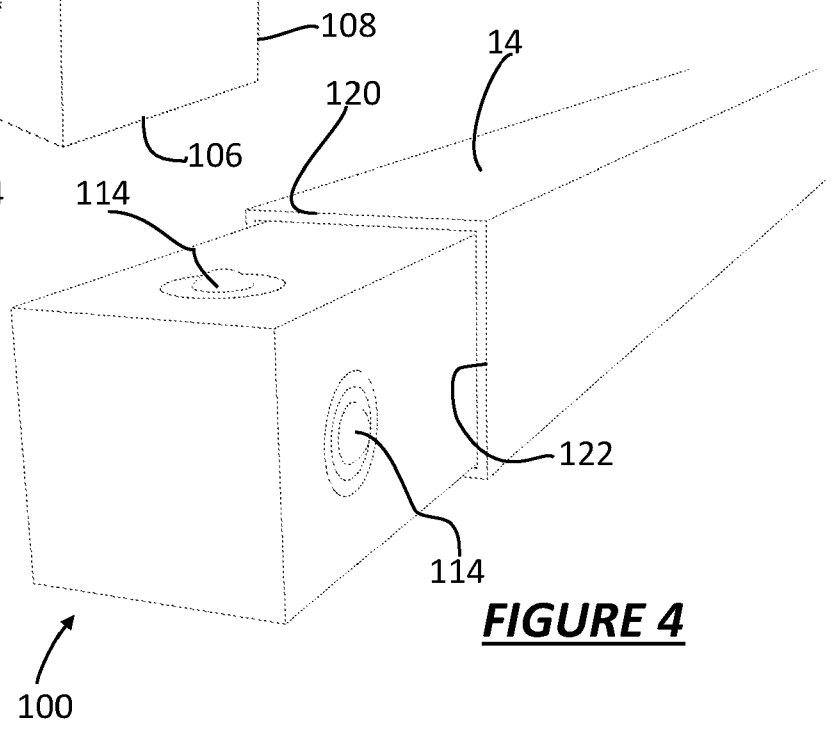

FIGURE 4

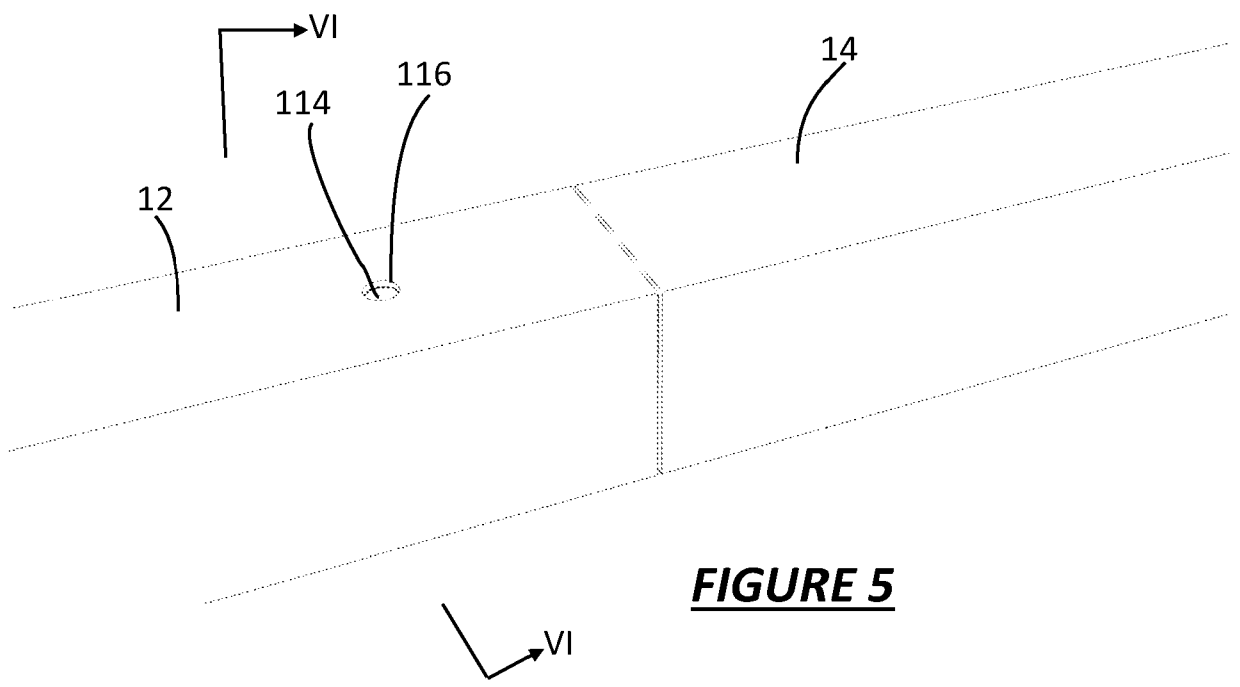

FIGURE 5

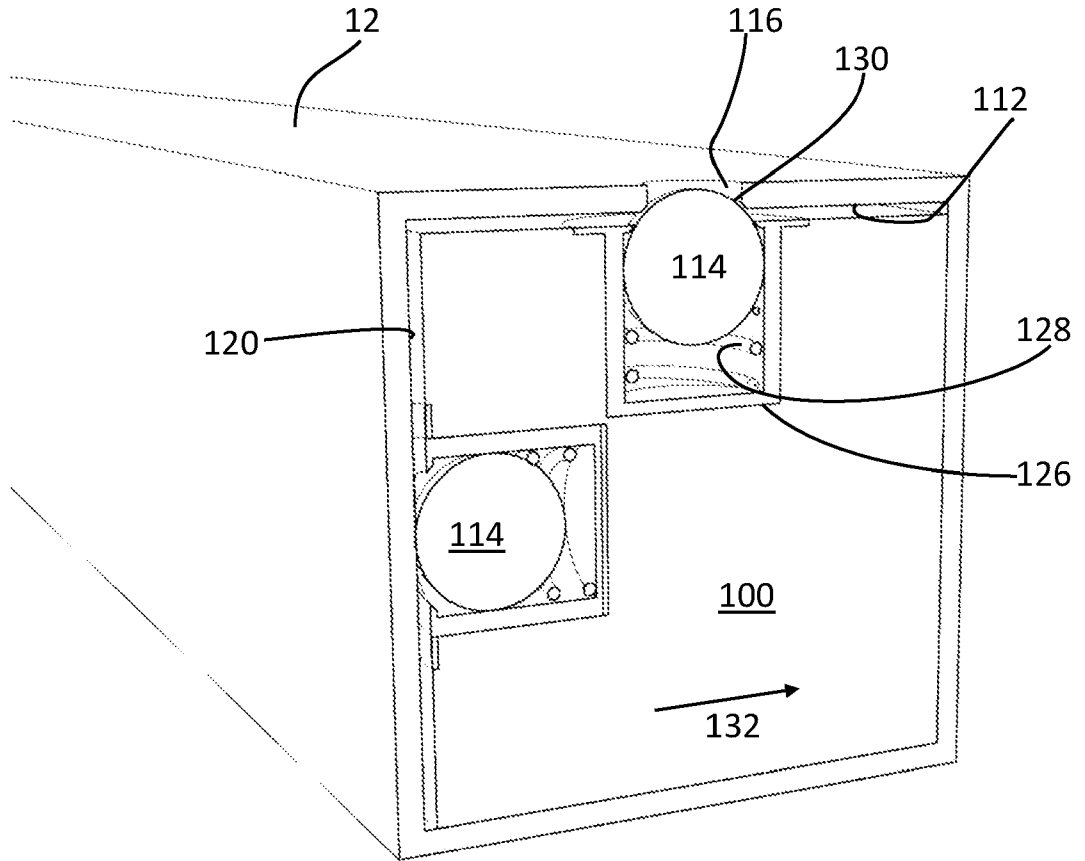

FIGURE 6

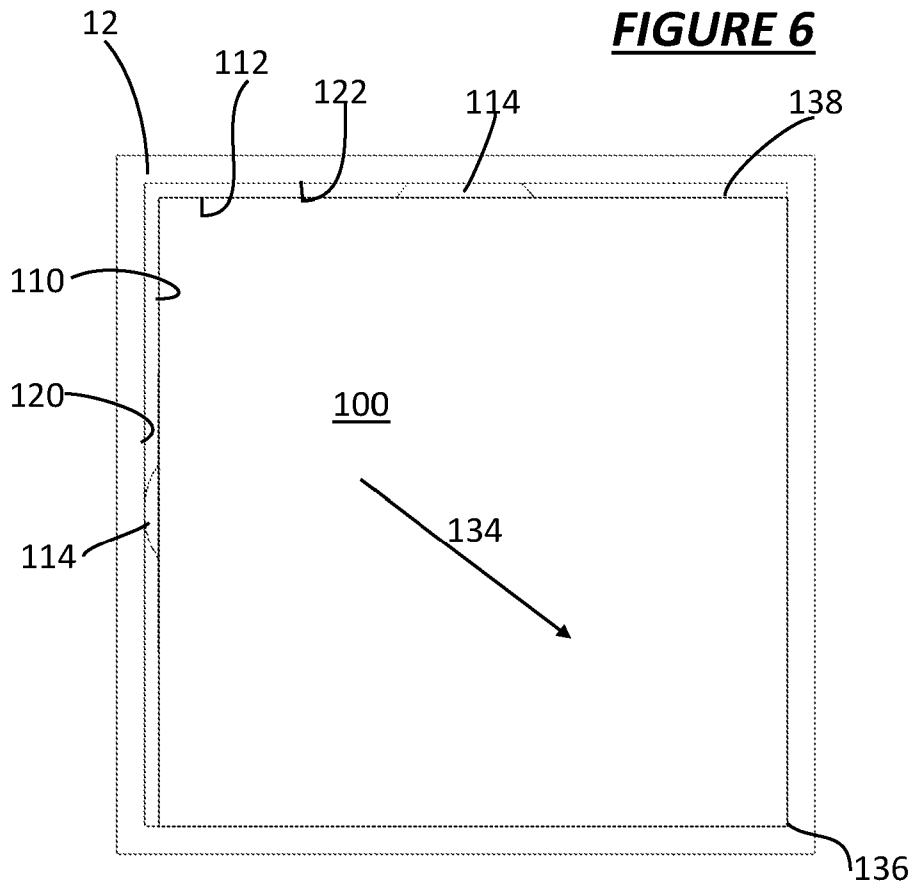

FIGURE 7

BUILDING PROFILE EXTENSIONS

This invention relates to building profile extensions.

5 A building profile is a device used in the construction industry for aligning the bricks or blocks when constructing a building. In order to ensure the structural integrity and aesthetics of a building being constructed, the courses of bricks need to be both level and plumb so that loads are transmitted vertically downwards into the foundations, and so that window and door apertures, etc., as well as the roofline are also level and plumb. However, because the individual bricks are separated by mortar, any deviation in the thickness and/or width of the mortar between adjacent bricks can give rise to errors and misalignment. Indeed, it is an extremely skilled bricklayer who can apply a consistent thickness of mortar to all sides of a brick as it is laid, but even in the best possible case, cumulative errors over the length of a course of bricks can be significant.

15 In order to ameliorate this, it is conventional practice to lay each brick at the corner of a building level and plumb, for example using a spirit level. This is an extremely time-consuming procedure, and so, more recently, people have started to use a building profile to align the bricks when laying brickwork and/or block work. A building profile is simply a form, typically a straight edge, which can be affixed to the brickwork as it is built to provide an edge against which the bricks can be placed so as to ensure correct alignment and spacing of the bricks.

20 In order for a building profile to function as it should, it is necessary that the building profile is set up level and plumb because any errors in the alignment of the building profile will be translated into errors in the alignment of the brickwork. The setting-up of a building profile is therefore a skilled task that requires a considerable investment in time – typically around 20 minutes for known building profiles.

25 A known building profile arrangement is typically manufactured from a length of square cross-section metal (e.g. steel or aluminium) tubing, which is clamped to a wall using a pair of F-Clamp. Once clamped using a first F-Clamp, usually located at or towards the bottom end of the building profile, the profile is checked for level and plumb using a spirit level placed against two or more of its sides. With the building profile clamped at a single point to the wall, it is possible to pivot and/or manoeuvre it into correct alignment and to hold it there by using packing pieces or shims between the building profile and the wall surface. Once the building profile has been correctly positioned and it has been checked for level and plumb, a second F-Clamp can be used to finalise and fix the position of the building profile relative to the wall. A portion of the building profile thus protrudes above the existing brickwork courses and this (vertically extending) portion can be used as an alignment guide for subsequent bricklaying.

It will be appreciated from the foregoing that the installation and configuration of a known building profile is a somewhat skilled and time-consuming procedure. Moreover, because the packing/shims are generally just pieces of wood, cardboard or other waste material found on a building site, they are susceptible to movement and distortion, which can give rise to errors as well.

5 A known solution to this problem is disclosed in our earlier patent, GB2603011 (Carl Hitchenson, 27 July 2022), which discloses a building profile comprising: a straight, elongate main body having an end portion with at least one adjuster, the or each adjuster comprising: an at least partially screw threaded shaft extending through the main body, the thread of which screw-thread engages a complementary internally screw threaded part of the end portion of the main body; and a foot
10 moveably connected to the shaft, rotation of the shaft in a first direction causing the foot to extend beyond an outer surface of the main body and rotation of the shaft in a second direction opposite the first direction causing the foot to retract into the main body, wherein the end portion of the main body further comprises an internal guide for the or each adjuster, the internal guide having an internal profile that corresponds to an external profile of a respective foot, the internal guide permitting the
15 respective foot to be retracted into the main body such that a wall-engaging surface of the foot is at least flush with the outer surface of the main body.

The building profile described in GB2603011 provides an adequate solution to the afore-described problems, namely by enabling the building profile to be adjusted to plumb and square without the need for shims and the like - albeit only up to a height equal to the length of the straight,
20 elongated main body. If a wall needs to be constructed above this height or level, then an extension is required, or the building profile needs to be repositioned from a higher starting point.

The problem with adding an extension is that there can be play between the lower and upper sections of the elongate, main body portion, which can give rise to an ever-increasing error/deviation as the wall is constructed. For example, if there is any play between the lower and upper sections of
25 the building profile, even by half a degree, this can translate into several centimetres of error at the upper end of the upper profile. The known solution to this is to erect a scaffold around where the building is to be constructed and to hang the building profile from a level above the intended upper storey. This means that the effects of gravity tend to hold the interconnected building profiles in a relatively straight configuration, but this also has disadvantages in terms of needing a scaffold to be
30 erected and so on.

At the present time, there is no obvious solution to this problem, namely that of extending an already-installed building profile upwards, which the present invention aims to provide.

Aspects of the invention are set forth in the appended independent claim or claims. Preferred and/or optional features of the invention are set forth in the appended dependent claims.

One aspect of the invention provides a building profile extension comprising a main body portion having a length, a width and a depth, the width and depth of the main body being smaller than the internal width and depth, respectively, of a pair of straight, elongate, tubular body portions of the building profile that the connector, in use, connects together, main body having first and
5 seconds ends respectively slideably receivable within opposing ends of the straight, elongate, tubular body portions, wherein two adjacent side faces of the main body are each provided with at least two resilient projections that extend substantially perpendicularly from the side faces, such that when the main body of the connector is slideably inserted into the opposing ends of the straight, elongate, tubular body portions of the building profile, the resilient projections engage the respective opposing
10 internal walls of the straight, elongate, tubular body portions of the building profile thereby urging an edge of the main body opposite the two adjacent side faces of the main body into engagement with an internal corner of the straight, elongate, tubular body portions of the building profile.

Another aspect of the invention provides an extendable building profile comprising a straight, elongate, tubular body portion affixable, in use, to the base of a structure to be built upwardly from
15 the said base; and a connector comprising a main body portion having a length, a width and a depth, the width and depth of the main body being smaller than the internal width and depth, respectively, of the straight, elongate, tubular body portion, the connector having a first end slideably receivable in end of the straight, elongate, tubular body portion with a second end thereof extending beyond an end of the straight, elongate, tubular body portion, whereby, in use, a further straight, elongate,
20 tubular body portion is slideably receivable over the second end of the main body portion, and wherein two adjacent side faces of the main body are each provided with at least two resilient projections that extend substantially perpendicularly from the side faces, such that when the main body of the connector is slideably inserted into the opposing ends of the straight, elongate, tubular body portions of the building profile, the resilient projections engage the respective opposing internal
25 walls of the straight, elongate, tubular body portions of the building profile thereby urging an edge of the main body opposite the two adjacent side faces of the main body into engagement with an internal corner of the straight, elongate, tubular body portions of the building profile.

A further aspect of the invention provides a building profile comprising a pair of straight, elongate, tubular body portions, at least one of which is affixable, in use, to the base of a structure to
30 be built upwardly from the said base; and a connector comprising a main body portion having a length, a width and a depth, the width and depth of the main body being smaller than the internal width and depth, respectively, of the straight, elongate, tubular body portions, the connector having a first end slideably receivable in end of a first one of the straight, elongate, tubular body portions and a second end slideably receivable within an end of the second straight, elongate, tubular body portion, wherein

two adjacent side faces of the main body are each provided with at least two resilient projections that extend substantially perpendicularly from the side faces, such that when the main body of the connector is slideably inserted into the opposing ends of the straight, elongate, tubular body portions of the building profile, the resilient projections engage the respective opposing internal walls of the straight, elongate, tubular body portions of the building profile thereby urging an edge of the main body opposite the two adjacent side faces of the main body into engagement with an internal corner of the straight, elongate, tubular body portions of the building profile.

The connector of the invention therefore provides a self-aligning mechanism, which ensures, in use, that the connected building profiles are always in-line and parallel. This is accomplished by the resilient projections that engage the internal walls of the building profiles themselves thus wedging or urging the main body portion of the connector into an opposite corner of the building profiles.

In a preferred embodiment of the invention, the main body portion of the connector is substantially cuboid, and most preferably, a square prism. This means that it can be inserted into a correspondingly square-sectioned tubular building profile and where it is a square prism, it does not matter which axial rotation the main body is inserted into the ends of the building profiles.

There is a small gap between the outer side walls of the main body and the inner side walls of the building profiles themselves. This gap is preferably as small as possible, but nevertheless sufficient to enable easy sliding of the main body into the ends of the building profiles. Preferably, therefore, the clearance between the main body and the building profiles is between 0.25mm and 1mm all round. This essentially means that the width and depth of the main body portion are between 0.5 and 2mm smaller than the internal width and depth, respectively, of the building profiles.

Preferably, the resilient projections are spring-loaded ball bearings. These are suitably provided by way of a spring-loaded assembly, which comprises an open-topped hollow cylinder. Typically, there is a cylindrical tube having a base wall at one end and an open end at the other. The open end has an internal lip, which captures a ball bearing within the tube. A compression spring is located between the base wall and the ball bearing, thus urging the ball bearing axially outwardly until it engages with the lip at the end of the tube. To facilitate assembly of the spring-loaded ball bearing assembly, the internal lip is suitably provided by way of a screw-down end face the central aperture therein. The compression spring thus urges the ball bearing axially outwardly, and thereby into engagement with the inner walls of the building profiles, in use. However, the available movement of the ball bearing in the ball bearing assembly is greater than the clearance mentioned above. This means that the ball bearings need to be compressed inwardly slightly to fit the connector into the ends of the building profiles and the ball bearings are thus urged into positive engagement with the internal walls of the building profile when the connector is inserted.

Moreover, by placing the resilient members on adjacent side walls of the main body of the connector, this means that the opposite edge of the main body is pushed in two directions, which resolves along the diagonal of the cross-section of the main body. This forces the opposite corner of the main body into engagement with the internal corner of the building profiles thus ensuring that the connector is positively engaged with, and held parallel to, the axis of the building profiles.

By inserting two building profiles onto the connector – one from either side, this arrangement conveniently ensures that both building profiles are held in a parallel and co-planar arrangement/relationship with one another. This addresses the problem of play mentioned previously.

In one possible embodiment of the invention, at least one of the building profiles may be provided with an internal recess or a through-hole, which is positioned on the building profiles such that one of the ball bearings of the resilient engagement means can engage with that recess or through-hole when the connector is inserted into the end of the building profile. This creates a spring-loaded détente connection between the connector and at least one of the building profiles. The advantage of this particular configuration is that where the apertured or recessed building profile is arranged vertically, when the connector is inserted into it, the connector does not simply drop down through the building profile and out of the bottom as the ball bearing will, at some point, engage with a recess or through-hole and thus retain the connector at a substantially fixed axial position relative to the building profile.

In a preferred embodiment of the invention, when a through-hole is provided, there is a chamfer at the edge between the side wall of the through-hole and the internal side wall of the building profile. This creates a 'cup-and-cone' configuration between the through-hole and the ball bearing thus self-locating and self-centralising the ball bearing within the through-hole. Preferably, the through-hole is formed as a slightly elongated slot which runs perpendicular to the axis of the building profile. This enables the ball bearing to engage with the through-hole and thus prevent the connector from falling through the tube, whilst also permitting the connector to move perpendicular to an axis of the building profile as it is pushed into the opposite corner of the building profile as previously described.

Preferably, the building profiles are manufactured from straight, elongate tubular lengths of square-section aluminium tubing. The connector is preferably manufactured from plastics. In a preferred embodiment of the invention, the connector is manufactured from recycled plastics, such as recycled polyethylene/polypropylene, or it could even be a composite material, such as a composite plastics material comprising fibrous or particulate filler and a recycled polymer matrix. The fibrous or particulate filler could be any suitable filler material, but is preferably waste material such as sawdust,

shredded paper or wood, metal swarth or powder, ceramic powder or chips, shredded chipped or powdered waste thermosetting plastics and/or organic waste material. The advantage of using a composite material as opposed to a solid block of polymer is that it tends to be more isotropic in properties, lighter in weight and also better for the environment as it enables otherwise non-recyclable products to simply be ground up and used as a filler material in the main body of the invention.

Embodiments of the invention shall now be described, by way of example only, with reference to the accompanying drawings in which:

Figure 1 is a partially exploded view of a known multi-part building connector;

Figure 2 is a partial cross-section of the multi-part building profile of Figure 1 when assembled;

Figure 3 is a perspective view of a connector in accordance with the invention;

Figure 4 is a perspective view of the connector of Figure 3 partially inserted into a building profile; and

Figure 5 is a perspective view of an extended building profile in accordance with an aspect of the invention.

A known building profile 10 can be made up from two tubular, aluminium, square-section tubes 12, 14, with a connector piece 16 located therebetween. The connector piece 16 can be a solid block as described herein, or it could be a further tubular member which is nested into one of the ends of the building profiles 12. It can be seen that the external dimensions of the connector 16 are slightly smaller than the internal dimensions of the building profiles 12, 14 such that they can be fitted together, end-to-end, as shown in Figure 2. As can be seen in Figure 2, when the two building profiles 12, 14 are pushed together end-to-end with a connector 16 therebetween, they are not perfectly aligned and there is thus some discrepancy between the axes of the building profiles 12, 14 as well as the planarity of their outer side faces. This creates errors in the building profile which are obviously exaggerated the further away from the connector 16 one moves.

Turning now to Figure 3 of the drawings, a connector 100 in accordance with the invention comprises a main body 102, which is manufactured from a solid block of recycled plastics material. The main body 102 has a length 104, a width 106 and a height 108 the latter of which are the same thereby creating a square prism shaped block of length 104. Two adjacent side faces 110, 112 are provided, towards their opposite ends, spring-loaded ball bearings 114, which project perpendicularly outwardly from the side faces 110, 112. The ball bearings 114 can be pushed inwardly against the action of a spring, which shall be described in greater detail below.

Turning to Figure 4 of the drawings, the connector 100 is inserted halfway into the end of a first building profile 14 and the ball bearings 114, which are located within the building profile 14 are an engagement with the inner side walls 120, 122 of the building profile.

5 Turning to Figure 5 of the drawings, the same configuration as that shown in Figures 3 and 4 has been completed by the addition of a further building profile 12, which has a through-hole 116 in one of its side faces, which engages one of the ball bearings 114 to form a spring-loaded détente connection between the connector 100 and left-hand building profile 12.

10 Turning now to Figure 6 of the drawings, a cross-section of Figure 5 is shown on VI-VI. In this cross-section it can be seen that the ball bearings 114 are urged into engagement with the inner side walls 120, 122 of the building profile 12. The ball bearings 114 are held within a tube 126, which has a compression spring 128 within it, which urges the ball bearings outwardly as shown in Figure 6.

15 The uppermost ball bearing 114 in Figure 6 projects partially into the through-hole 116, which has a chamfered inner edge 130, which centralises the ball bearing 114 in the hole 116. Although not clearly visible in Figures 5 and 6, the through-hole 116 is actually slotted slightly meaning that the connector 100 is able to slide right 132 in the drawings without the through-hole 116 preventing it from doing so by its engagement with the ball bearing 114.

Meanwhile, the other ball bearing, which is located in an adjacent side wall of the connector 100 is spring-loaded against the other adjacent internal side wall 120 of the building profile 12.

20 Turning to Figure 7 of the drawings, it can be seen that the spring-loaded arrangement causes the building profile 100 to be pushed 134 diagonally into the internal corner 136 of the building profile 12 leaving any tolerance or gap 138 between the outer surfaces 110, 112 of the main body 100 and the inner surfaces 122, 120 of the building profile 12. This ensures that the main body of the connector 100 is parallel to the building profiles 12, 14.

25 The invention is not restricted to the details of the foregoing embodiment which are merely exemplary of the invention.

The invention is not restricted to these specific details of the forgoing embodiments which are merely exemplary. For example, the invention is not restricted to any particular materials or dimensions that have been mentioned herein.

CLAIMS

1. A connector for a building profile extension comprising:
 - a main body portion having a length, a width and a depth, the width and depth of the main body being smaller than the internal width and depth, respectively, of a pair of straight, elongate, tubular body portions of the building profile that the connector, in use, connects together,
 - the main body having first and second ends respectively slideably receivable within opposing ends of the straight, elongate, tubular body portions, wherein
 - two adjacent side faces of the main body are each provided with at least two resilient projections that extend substantially perpendicularly from the side faces, such that
 - when the main body of the connector is slideably inserted into the opposing ends of the straight, elongate, tubular body portions of the building profile, the resilient projections engage the respective opposing internal walls of the straight, elongate, tubular body portions of the building profile thereby urging an edge of the main body opposite the two adjacent side faces of the main body into engagement with an internal corner of the straight, elongate, tubular body portions of the building profile.

2. An extendable building profile comprising:
 - a straight, elongate, tubular body portion affixable, in use, to the base of a structure to be built upwardly from the said base; and
 - a connector according to claim 1,
 - a first end of the connector being slideably receivable in an end of the straight, elongate, tubular body portion with a second end thereof extending beyond an end of the straight, elongate, tubular body portion, whereby, in use,
 - a further straight, elongate, tubular body portion is slideably receivable over the second end of the main body portion, such that:
 - when the main body of the connector is slideably inserted into the opposing ends of the straight, elongate, tubular body portions of the building profile, the resilient projections engage the respective opposing internal walls of the straight, elongate, tubular body portions of the building profiles thereby urging the edge of the main body opposite the two adjacent side faces of the main body into engagement with an internal corner of the straight, elongate, tubular body portions of the building profiles.

3. A building profile comprising:
 - a pair of straight, elongate, tubular body portions, at least one of which is affixable, in use, to the base of a structure to be built upwardly from the said base; and
 - a connector according to claim 1;
 - the first end of the connector being slideably receivable in an end of a first one of the straight, elongate, tubular body portions and
 - the first end of the connector being slideably receivable within an end of the second straight, elongate, tubular body portion, wherein:
 - when the main body of the connector is slideably inserted into the opposing ends of the straight, elongate, tubular body portions of the building profile, the resilient projections engage the respective opposing internal walls of the straight, elongate, tubular body portions of the building profile thereby urging an edge of the main body opposite the two adjacent side faces of the main body into engagement with an internal corner of the straight, elongate, tubular body portions of the building profile.
4. The connector, extendable building profile or building profile of claim 1, 2 or 3, wherein the main body portion of the connector is substantially cuboid.
5. The connector, extendable building profile or building profile of claim 4, wherein the main body portion of the connector has a square prism shape.
6. The connector, extendable building profile or building profile of any preceding claim, wherein the width and depth of the main body portion are between 0.5mm and 2mm smaller than the internal width and depth, respectively, of the pair of straight, elongate, tubular body portions,
7. The connector, extendable building profile or building profile of any preceding claim, wherein the resilient projections comprise spring-loaded ball bearings.
8. The connector, extendable building profile or building profile of claim 7, wherein the resilient projections comprise spring-loaded ball bearings are retained by a tube having an internal lip that prevents complete egress of the ball bearing axially from an open end of the tube, a base wall at the opposite end of the tube to the open end, and a compression spring interposed between the base and the ball bearing which urges the ball bearing into engagement with the internal lip.

9. The connector, extendable building profile or building profile of claim 7 or claim 8, wherein when the spring-loaded ball bearings are in engagement, in use, with their respective internal side wall of the straight, elongate tubular body portions, the ball bearing is set back from the internal lip such that the spring urges the ball bearing into positive engagement with the said internal side wall of the straight, elongate tubular body portion.
10. The connector, extendable building profile or building profile of claim 7, 8 or 9, wherein at least one of the straight, elongate tubular body portions comprises a through-hole or internal recess aligned with one of the ball bearings when the connector is inserted into an end of the straight, elongate tubular body portion, such that the ball bearing at least partially projects into the through-hole or internal recess thereby forming a spring-loaded detent connection between the connector and the straight, elongate tubular body portion.
11. The connector, extendable building profile or building profile of claim 10, wherein the through-hole comprises a chamfer at the edge between the side wall of the through-hole and the internal side wall of the straight, elongate tubular body portion.
12. The connector, extendable building profile or building profile of claim 10 or claim 11, wherein the through-hole is a slot.
13. The connector, extendable building profile or building profile of any preceding claim, wherein the straight, elongate tubular body portion are manufactured from square-section, aluminium tubing.
14. The connector, extendable building profile or building profile of any preceding claim, wherein the connector is manufactured from plastics.
15. The connector, extendable building profile or building profile of any preceding claim, wherein the connector is manufactured from recycled plastics.
16. The connector, extendable building profile or building profile of claim 15, wherein the connector is manufactured from a composite plastics material comprising fibrous or particulate filler and a recycled polymer matrix.

17. The connector, extendable building profile or building profile of claim 16, wherein the fibrous or particulate filler comprises any one or more of: sawdust; shredded paper or wood; metal swarf or powder; ceramic powder or chips; shredded, chipped or powdered waste thermosetting plastics; and organic waste material.



Application No: GB2304086.8

Examiner: Mr Haydn Gupwell

Claims searched: 1-16

Date of search: 25 September 2023

Patents Act 1977: Search Report under Section 17

Documents considered to be relevant:

Category	Relevant to claims	Identity of document and passage or figure of particular relevance
A	None	GB2220435 A (RICCIO A)
A	None	US2006/059856 A1 (GILLILAND J T)
A	None	GB2134580 A (BURKE T)
A	None	US1457964 A (HARRY DOTY)
A	None	US2015/078815 A1 (GE WENDY; LIU BRENNNA)
A	None	US4431331 A1 (BRODY CHARLES)
A	None	US3603628 A (SMITH EDWARD A; DAY ROBERT L)

Categories:

X	Document indicating lack of novelty or inventive step	A	Document indicating technological background and/or state of the art.
Y	Document indicating lack of inventive step if combined with one or more other documents of same category.	P	Document published on or after the declared priority date but before the filing date of this invention.
&	Member of the same patent family	E	Patent document published on or after, but with priority date earlier than, the filing date of this application.

Field of Search:

Search of GB, EP, WO & US patent documents classified in the following areas of the UKC^X :

--

Worldwide search of patent documents classified in the following areas of the IPC

E04G; F16L

The following online and other databases have been used in the preparation of this search report

WPI, EPODOC



International Classification:

Subclass	Subgroup	Valid From
E04G	0021/18	01/01/2006