

Feb. 28, 1967

C. G. SIMCOX

3,306,222

ELECTRICALLY DRIVEN CIRCULATING PUMP

Filed June 7, 1965

4 Sheets-Sheet 1

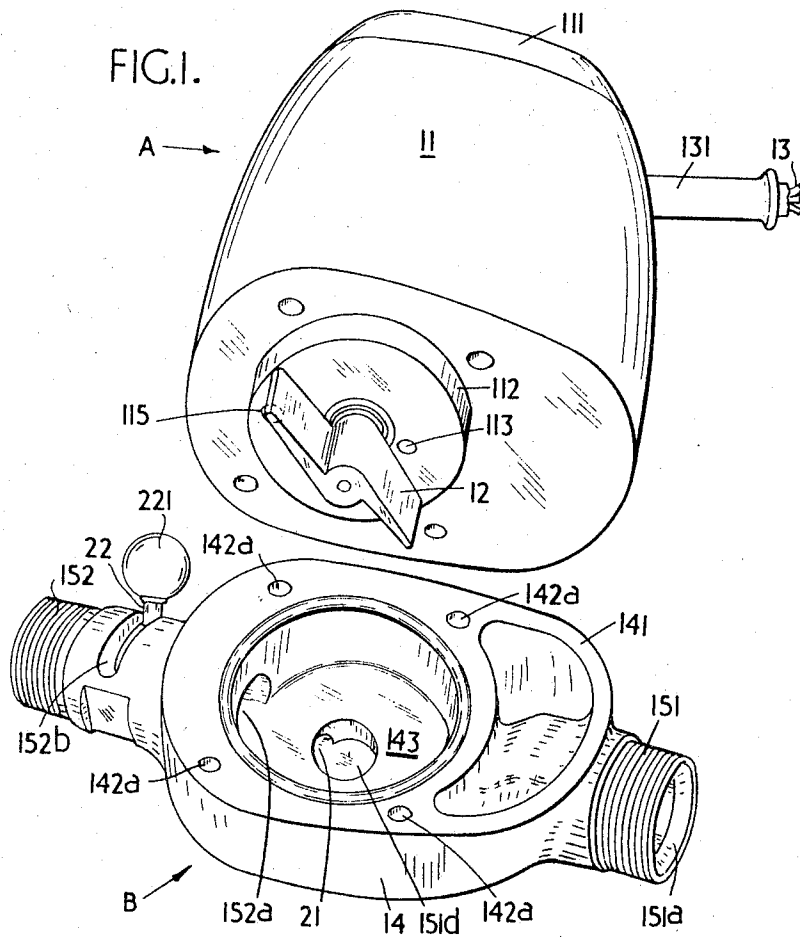

Clifford George Simcox
By Henryway, Jamney & Hildreth
Att'ys.

Feb. 28, 1967

C. G. SIMCOX

3,306,222

ELECTRICALLY DRIVEN CIRCULATING PUMP

Filed June 7, 1965

4 Sheets-Sheet 2

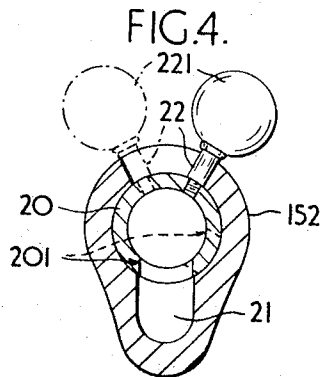
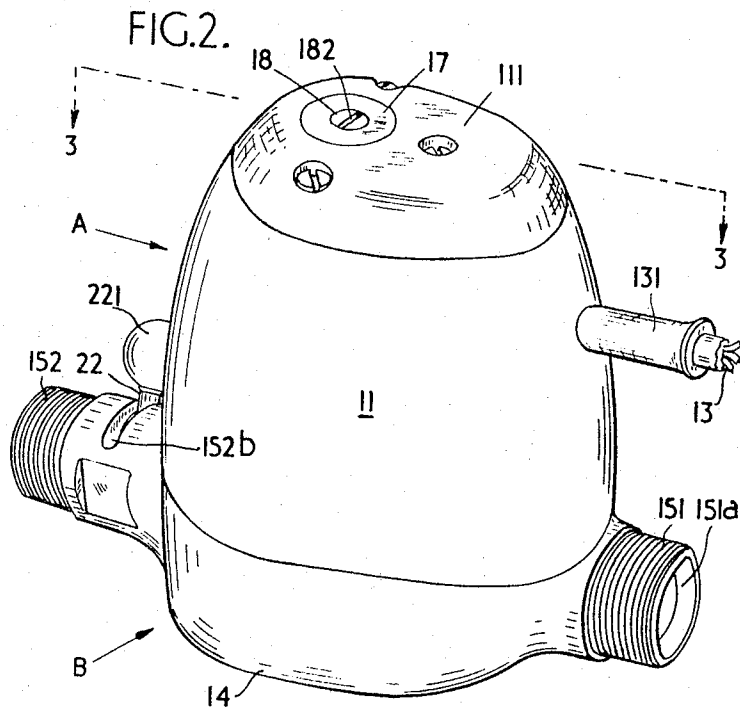

Clifford George Simcox
By Henry J. Jansky & Tildredt.
Att'ys.

Feb. 28, 1967

C. G. SIMCOX

3,306,222

ELECTRICALLY DRIVEN CIRCULATING PUMP

Filed June 7, 1965

4 Sheets-Sheet 4

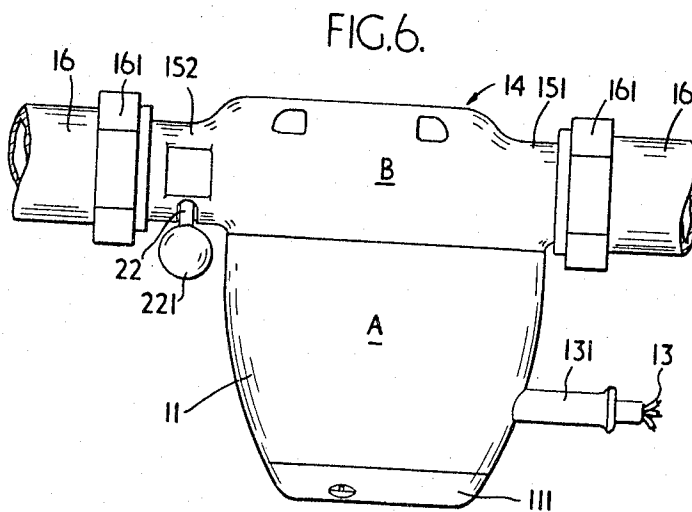
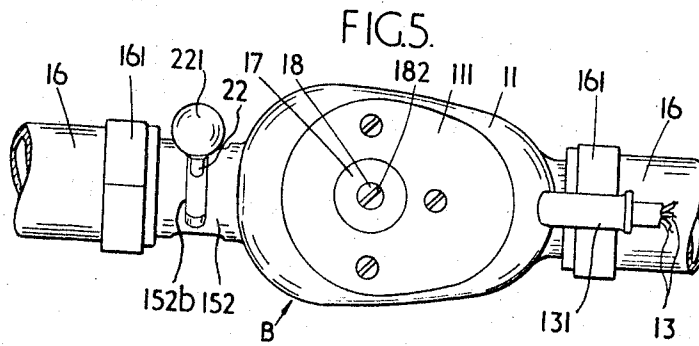

Clifford George Simcox
by Fenway, Jenney & Hildreth
Att'ys.

1

2

3,306,222

ELECTRICALLY DRIVEN CIRCULATING PUMP
 Clifford George Simcox, Walmley, Sutton Coldfield, Eng-
 land, assignor to James Beresford & Son Limited, Bir-
 mingham, England, a corporation of Great Britain
 Filed June 7, 1965, Ser. No. 462,692
 Claims priority, application Great Britain, June 25, 1964,
 25,232/64
 6 Claims. (Cl. 103—87)

This invention has reference to electrically driven circulating pumps and is concerned more particularly but not specifically with electrically driven circulating pumps for incorporation in hot water heating systems of the forced circulation type.

The present invention has for its primary object to provide an electrically driven pump for incorporation in the pipelines of hot water heating systems of the aforesaid type which is simple in construction, readily adaptable for fitment in the pipelines of hot water heating installations and which is efficient in operation and capable of being produced at a relatively low cost.

Accordingly the invention consists of an electrically driven circulating pump comprising the unitary assembly of a self-contained electric motor unit which is encased in a synthetic plastics material possessing good electrical insulating properties, good heat conductivity and strength and which has a rotor to one end of the spindle whereof is fitted a pump impeller and a separately formed pipeline connection unit which is fitted to the encasement of the electric motor unit and which is adapted for connection in the pipeline system for the liquid which is required to be circulated and which pipeline connection unit incorporates a chamber for the reception of the pump impeller, fitted to the rotor spindle so that when the pipeline connection unit is fitted to the electric motor unit the said impeller and chamber then constitute a rotary pump and inlet and outlet passages in communication with said chamber.

The invention also resides in an electrically driven circulating pump constructed substantially as will be described hereinafter.

An embodiment of the invention will now be described with particular reference to the accompanying drawings which illustrate the invention as applied to a circulating pump which is designed specifically for inclusion in the pipeline system of a conventional forced circulation hot water heating installation.

FIGURE 1 is a perspective view of the two major components of the pump shown separated,

FIGURE 2 is a perspective view of the assembled pump looking from above,

FIGURE 3 is a vertical section of the assembled pump taken on the plane indicated by the line 3—3 in FIGURE 2,

FIGURE 4 is a fragmentary view in cross section, the section being taken on the plane indicated by the line 4—4 in FIGURE 3 looking in the direction of the arrows to the said line,

FIGURES 5 and 6 are diagrammatic views illustrating alternative ways of mounting the pump unit in the pipeline of a forced circulation hot water heating installation.

In the drawings like numerals of reference indicate similar parts in the several views.

According to the said illustrated embodiment of the invention the circulating pump comprises two separately formed units which are fitted to one another to constitute a unitary assembly, namely an encapsulated self-contained electric motor unit designated generically by the reference letter A having a vertical rotor to the spindle of which is fitted a pump impeller and a pipeline connection unit designated generically by the reference letter B which in-

corporates inlet and outlet passages and a chamber for the reception of and to constitute the working chamber for the said pump impeller.

The self-contained encapsulated electric motor unit A incorporates an electric motor of the shaded pole squirrel cage type designated generically by the reference numeral 10 (FIGURE 3) the stator pack 101 whereof is of conventional construction and is mounted to one side of the rotor chamber 102 and which is completely encapsulated by moulding in an encasement 11 of a synthetic plastics material having good insulating properties, good heat conductivity and strength, as for example the synthetic plastics material sold in commerce under the registered trademark "Araldite."

The rotor chamber 102 aforesaid is open at the top and is adapted to be closed by a detachable cover 111 made of the same synthetic plastics material as the said encasement 11, the contour of the said detachable cover 111 being such as to continue the contour of the main body of the encasement 11. The intermediate portion of the rotor chamber 102 proper is bounded by a thin sleeve 103 of stainless steel (see FIGURE 3) which is bonded to the encasement 11 in a manner itself known.

The encasement 11 is provided with a bottom bearing 105 for a vertically disposed rotor spindle 104 of the electric motor 10 the lower end portion of which projects from the main body of the encasement 11 and has the impeller 12 of a rotary pump fixed thereto so that the said impeller 12 constitutes an element of the electric motor unit assembly A.

The bottom of the encasement 11 is provided with a shallow depending cylindrical closure boss 112 which is concentric with the bearing 105, said cylindrical boss 112 serving for a closure purpose to be referred to hereinafter.

Leads 13 for conducting electric current to the stator pack 101 together with a protective sheath 131 are embedded in and bonded to the encasement 11 during the moulding of the encasement 11.

The pipeline connection unit B is formed as a metal casting designated generically by the reference numeral 14 and is provided with a perimetrical flange 141 having therein holes 142a for the passage of bolts 142b through the medium of which the pipeline connection unit B may be secured to the bottom of the encasement 11 of the electric motor unit A to constitute a unitary assembly.

The said pipeline connection unit B is provided with oppositely disposed but axially aligned inlet and outlet pipe coupling sections 151 and 152 respectively which are adapted to be connected in the pipeline 16 by pipe coupling means 161 of known construction. The said inlet and outlet pipe coupling sections 151, 152 are associated with internal inlet and outlet passages 151a and 152a respectively of which the inlet passage 151a includes a downwardly inclined section 151b which continues in a straight section 151c which then continues in an upwardly turned section 151d which is concentrically disposed relatively to the rotor spindle 104 of the electric motor 10 when the two units are assembled.

The inwardly turned section 151d of the inlet passage 151a aforesaid opens into an open topped cylindrical chamber 143 of dimensions such that when closed in a manner to be described hereinafter the said chamber 143 will accommodate the impeller 12 of the electric motor unit A.

The open top of the chamber 143 is adapted to be closed by the aforesaid shallow cylindrical closure boss 112 at the bottom of the encasement 11 which plugs into the said open top of the chamber 143 when the pipe connection unit B is bolted to the electric motor unit A with the impeller 12 enclosed in the chamber 143 so that the closed chamber 143 then serves as the impeller chamber of a rotary pump and hence when enclosed

the said chamber 143 will be referred to hereinafter as the impeller chamber 143.

The impeller chamber 143 opens directly into the outlet passage 152a aforesaid and the said impeller chamber 143 is open also to a passage 113 in the encasement 11 which is in communication with the low pressure region of the impeller chamber 143 and in the high pressure region with a passage 115 in the mass of the encasement the upper end of which opens into the space 114 within which the upper portion of the rotor spindle 104 is disposed. The said space 114 is in communication with the passage 113 aforesaid by way of the rotor chamber 102. The passage 113, space 114 and passage 115 serve to circulate liquid as a coolant and lubricant for the bearings of the rotor spindle 104 and for the rotor 106 and also to prevent the formation of steam pockets which could cause the upper bearing for the rotor spindle 104 to run dry.

The detachable cover 111 has moulded therein a ferrule 17 having an inwardly directed portion 171 which projects into the space 114 of the encasement 11 and has a bearing sleeve 172 mounted therein for the reception of the upper end of the rotor spindle 104. The ferrule 17 is provided in the intermediate portion of the wall thereof with holes 173 which communicate with the bore of the ferrule 17 so that the circulating liquid which passes into the rotor chamber 102 by way of the passage 115 and space 114 in the upper portion can pass by way of the said holes 173 into the bore of the ferrule 17 to serve as a coolant for the upper bearing sleeve 172.

Slidably mounted within the ferrule 17 is a turnable plug 18 having in the inner end thereof a diametrical spigot 181 which can be pushed into register with and then into engagement with, when so required, a complementary diametrical slot 107 in the upper end of the rotor spindle 104 so that in the case of a sticking of the rotor 106 of the electric motor 10 the plug 18 may be pushed inwardly to engage with the slotted end portion of the rotor spindle 104 so as to enable a twist to be imparted to the rotor spindle 104 by engaging a screwdriver or like instrument within an external slot 182 formed in the outer end of the said plug 18. Normally the plug 18 is maintained out of engagement with the rotor spindle 104 by a coil spring 19 housed within the said ferrule 17.

The plug 18 may also be used to vent the rotor chamber 102 to atmosphere by depressing the said plug 18 as and when required.

Disposed within the outlet passage 152a and with the inner end thereof opening into the chamber 143 is a turnable sleeve 20 constituting a by-pass valve said sleeve 20 being provided with a hole 201 which can be brought into register with a complementary hole 211 in the inlet end of a by-pass passage 21 which forms a continuation of the inlet passage 151a. The sleeve 20 is provided with an outwardly projecting rod 22 the outer portion of which projects through a slot 152b in the outlet coupling section 152 and has a knob 221 fitted on the projecting end thereof so that by turning the sleeve 20 through the medium of the said rod 22 and knob 221 the degree of the opening of the hole 211 may be adjusted to suit the degree of by-pass which may be required.

The sleeve 20 is sealed by means of O-sealing rings 202 housed in internal pockets in the wall of the outlet passage 152a.

As will be apparent from FIGURE 2 the encasement 11 of the electric motor unit A is given a substantially ovoidal shape in cross section thus producing a body of a relatively slim configuration and slightly appearance yet with an extensive surface area to ensure adequate cooling of the electric motor 10 when in operation.

It will be appreciated that when the pump is installed in the pipeline 16 and the electric motor 10 is in action the water fed into the bottom of the impeller chamber

143 is urged out through the outlet passage 152a so that a forced flow of circulating liquid is obtained.

It will be appreciated that the encasement 11 of the electric motor unit A is made in two parts with one part incorporating a rotor chamber 102 which is open at the top, in order to allow of the fitment of the rotor 106.

An electrically driven circulating pump as hereinbefore described is simple in construction, efficient in operation, capable of being produced at a relatively low cost and provides an assembly which is slightly in appearance and occupies a small space when installed in a hot water heating system.

It will be appreciated also that the electrically driven circulating pump hereinbefore described may be modified in certain respects without departing from the scope of the invention claimed. For example the detachable cover 111 may be made of metal in which case the ferrule 17 will not be required and the detachable cover 111 itself may be fashioned to serve the purposes of the said ferrule 17. Further instead of bonding the stainless steel sleeve 103 to the encasement 11 the said sleeve 103 may be an insert in the encasement 11 and sealed by O-sealing rings. Moreover the pipeline connection unit B may be connected in the pipeline 16 through the medium of rubber sleeves instead of the known pipe couplings 161 to insulate against noise and vibration. In addition the pipe connection unit B may be made of synthetic plastics material instead of metal.

It will be understood that the pump may be installed with the rotor in a position other than that shown in FIGURES 2 and 3, for example the electric motor unit A may be arranged with its axis in the same horizontal plane as the axis of the pipeline 16 as indicated in FIGURE 5 or depending from the said pipeline as is indicated in FIGURE 6.

Although a circulating pump in accordance with the invention is intended more particularly for effecting forced circulation of the water in hot water installations it is to be understood that the invention is not limited to such an application but may be applied to liquid circulating pumps for other purposes.

I claim:

1. An electrically driven circulating pump comprising the unitary assembly of a separately formed self-contained electric motor unit and a separately formed pipeline connection unit, said separately formed self-contained electric motor unit incorporating a body consisting of an encasement of a synthetic plastics material possessing good electrical insulating properties, good heat conductivity and strength, a stator unit embedded in the encasement, a rotor chamber in the mass of the encasement, a thin metal sleeve bounding the rotor chamber, rotor disposed within the rotor chamber, a spindle for said rotor, a bearing for the inner end of said spindle mounted within the encasement, a detachable means for closing one end of the encasement which on removal permits of access being gained to the rotor chamber for effecting the insertion of and the removal of the rotor as required, a pump impeller fixed on the inner end of the spindle which projects from the encasement bearing, said separately formed pipeline connection unit incorporating liquid inlet and outlets, a pump chamber intermediate said inlet and outlets, means for attaching the separately formed pipe connection unit to the said separately formed self-contained electric motor unit so that the high pressure side of the pump chamber of the impeller then becomes located within the pump chamber, a passage through the encasement which leads from the high pressure side of the pump chamber of the assembly into a space around the outer bearing of the spindle and thence into the rotor chamber and a passage through the encasement leading from the rotor chamber to the low pressure side of the pump chamber of the assembly, said passages in addition to serving to conduct coolant to and from the rotor chamber and outer spindle

5

bearing serve also to circulate coolant through the mass of the encasement.

2. An electrically driven circulating pump as claimed in claim 1 in which the inlet of the pipe connection unit communicates with a by-pass passage which opens into the outlet of the said pipe connection unit and in which valve means is provided for controlling the discharge through said by-pass.

3. An electrically driven circulating pump as claimed in claim 1 in which said detachable means incorporates a bearing for the outer end of the rotor spindle.

4. An electrically driven circulating pump as claimed in claim 1 in which said detachable means incorporate means for imparting a twist to the rotor spindle as required.

5. An electrically driven circulating pump as claimed in claim 1 in which the detachable means is formed of similar material to the encasement and is shaped to

6

constitute a continuation of the external contour of the encasement.

6. An electrically driven circulating pump as claimed in claim 1 in which the detachable means is formed of different material to the encasement.

References Cited by the Examiner

UNITED STATES PATENTS

3,026,808	3/1962	Immovilli	-----	103—87
3,119,342	1/1964	White	-----	103—87
3,228,341	1/1966	Hungerford	-----	103—87

FOREIGN PATENTS

580,080	10/1924	France.
121,552	4/1948	Sweden.

ROBERT M. WALKER, *Primary Examiner.*