

May 8, 1962

D. FUGERE

3,033,309

RETRACTIBLE STEPLADDER FOR VEHICLES

Filed Nov. 6, 1959

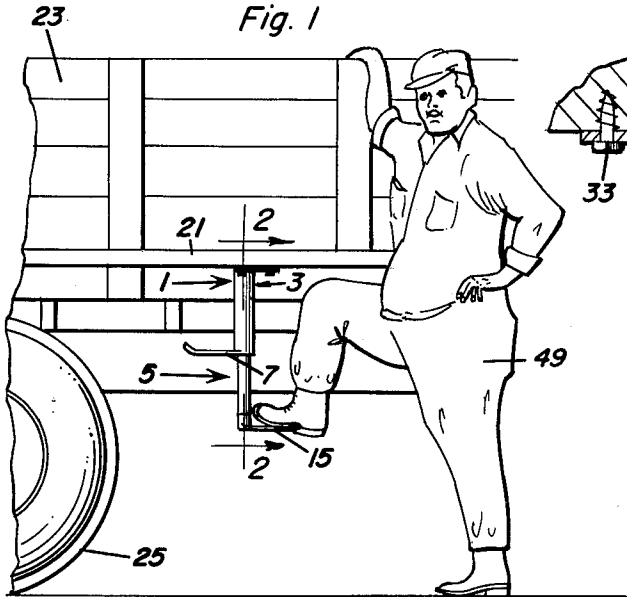

Fig. 1

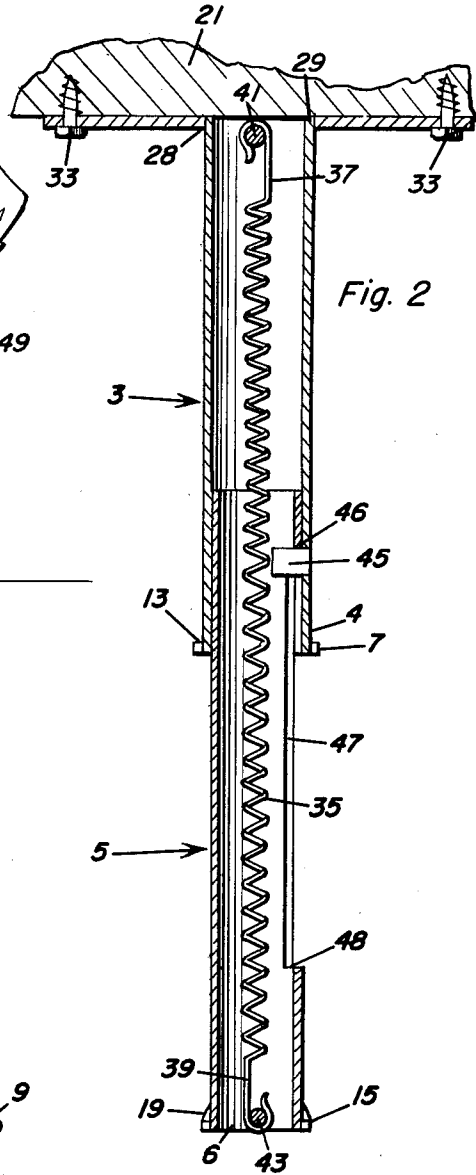

Fig. 2

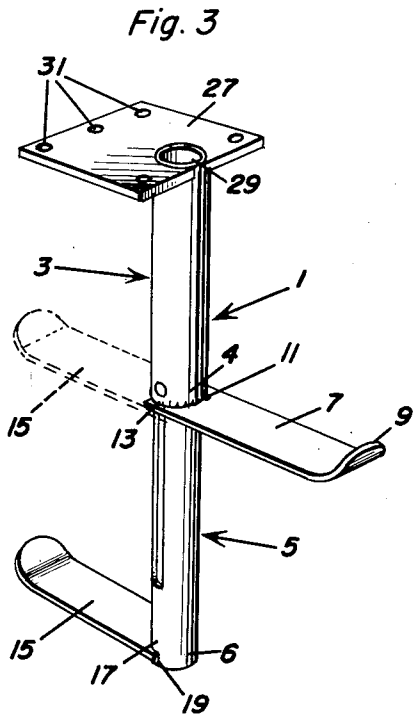

Fig. 3

Dale Fugere

INVENTOR.

BY *Chance W. Dixon*
and Harvey B. Jacobson
Attorneys

1

3,033,309

RETRACTIBLE STEPLADDER FOR VEHICLES

Dale Fugere, P.O. Box 293, Dunseith, N. Dak.

Filed Nov. 6, 1959, Ser. No. 851,450

3 Claims. (Cl. 182-90)

This invention relates to improvements in retractible stepladders for use on motor trucks, trailers, and the like by drivers or other persons ascending into or descending from such vehicles.

The primary object of the invention is to provide a ladder of simple, practical form for the above purpose and which is attachable in suspended position to such vehicles and includes an upper step carrying support attachable to the vehicle and a lower step carrying support normally retracted upwardly, when not in use, into an out-of-the-way position and adapted to be projected and lowered into suspended position in response to foot pressure thereon by a person using the ladder to ascend into the vehicle or to descend therefrom.

Another object is to provide a ladder according to the foregoing which is telescopic for retraction and lowering of the lower step carrying support whereby to guide said lower step carrying support in retraction or projection and lowering thereof.

Still another object is to provide in a ladder according to the foregoing means of simple form for retracting the lower step support.

Still another object is to provide in such a ladder, efficient means for limiting retraction, and projection or lowering of the lower step support relative to the upper step support.

Yet another object is to provide a ladder according to the foregoing which is safe, easy to attach and detach, is light in weight, yet strong and can be manufactured at a low cost.

These together with other objects and advantages which will become subsequently apparent reside in the details of construction and operation as more fully hereinafter described and claimed, reference being had to the accompanying drawings forming a part hereof, wherein like numerals refer to like parts throughout, and in which:

FIGURE 1 is a fragmentary view in side elevation of a stepladder constructed in accordance with this invention with the upper step carrying support attached to the body of a vehicle and the lower step carrying support projected and lowered by foot pressure of a person preparing to ascend into the vehicle body;

FIGURE 2 is an enlarged fragmentary view in vertical section taken on the line 2-2 of FIGURE 1 with the lower step carrying support lowered, and

FIGURE 3 is a perspective view of the stepladder detached and drawn to a smaller scale with the lower step carrying support shown lowered in full lines and retracted in broken lines, the view being turned through an angle of ninety degrees relative to the illustration of the ladder in FIGURE 1.

Referring to the drawing by numerals, according to this invention, a stepladder, designated generally 1 is provided comprising an upright upper tubular step carrying support 3 and an upright lower tubular step carrying support 5 of smaller diameter than said upper support and which is slidably telescopically fitted in said upper support 3 for guided retraction upwardly therein and projection downwardly therefrom for lowering.

An upper elongated flat step 7 extends laterally horizontally from the lower end 4 of said upper step support 3 with an outer upturned end 9 to prevent a foot from slipping off said step, and a rear end notch 11 straddling said support 3 and welded, as at 13, thereto.

A lower step 15 like the upper step 7 extends laterally

2

horizontally from the lower end 6 of said lower step support 5 and is similarly attached to said lower support 5 by a rear end notch 17 and welding 19 to the lower end 6 of said lower support. The upper and lower steps 7, 15 extend oppositely relatively from relatively opposite sides of said upper and lower step supports 3, 5, respectively.

Means is provided for attaching the stepladder to the bottom 21 of the bed 23 of a motor truck 25, or like vehicle, comprising a horizontal attaching plate 27 welded, as at 28, on the upper end 29 of said upper support and through which said upper end 29 of said upper support opens for a purpose presently seen. Marginal bolt holes 31 are provided in the attaching plate 27 for receiving attaching screw bolts 33.

The means for retracting the lower step carrying support 5 comprises a helical tension spring 35 in said upper and lower supports 3, 5, with terminal hooks 37, 39 thereon hooking detachably around a pair of upper and lower crosspins 41, 43 fixed in the upper and lower ends 29, 6 of said upper and lower supports 3, 5 respectively. As will be seen, the hooks 37, 39 may be detached from the crosspins 41, 43 for removing and replacing the spring 35 through either end 29 or 6 when desired.

Means for limiting retraction and projection or lowering of the lower step carrying support 5 comprises a radial stop lug 45 suitably fixed to the upper step carrying support 3 and projecting into the lower step carrying support 5 through a longitudinal slot 47 in said lower support 5 having closed upper and lower ends 46, 48 respectively.

The operation and use of the described invention will be readily understood. Normally, as shown in FIGURE 3, in broken lines, the lower step carrying support 5 is retracted upwardly in the upper step carrying support 3 to retract and raise said lower section 5 and the lower step 15 into elevated out-of-the-way position established by engagement of the lug 45 with the lower end 48 of the slot 47. As a person 49, as shown in FIGURE 1, starts to ascend into the truck, or vehicle, 25, he places one foot on the lower step 15 and presses downwardly thereon, whereupon, the lower step carrying support 5 is projected downwardly into its limit of lowering movement as determined by engagement of the lug 45 with the upper end 46 of the slot 47. This spaces the lower step 15 below the upper step 7 so that the person 49 may ascend the ladder into a position to enter or climb into the truck or vehicle 25. As soon as the person 49 steps on the upper step 7 and releases the lower step 15, the lower step carrying support 5 and the lower step 15 are retracted into the out-of-the-way position as shown in FIGURE 1. In this connection, it will be noted that the stepladder is of a length such that when the lower step carrying support 5 is retracted to retract the lower step 15 that is when the ladder is in normal position, the lower step 15 is positioned below the upper step 7 within easy reach from the ground by the foot of a person 49 standing on the ground. In descending the person 49 first uses the upper step 7 and then steps onto the lower step 15, whereupon, the lower step support 5 and the lower step 15 are projected downwardly until the stop lug 45 engages the lower end 48 of the slot 47. Then the person may descend to the ground and as soon as this occurs, the lower step support 5 and the lower step 15 are retracted into the out-of-the-way position. As will be seen, the lug 45 and slot 47 prevent the lower step carrying support 5 and the lower step 15 from rotating relative to the upper step carrying support 3 and the upper step 7.

The foregoing is considered as illustrative only of the principles of the invention. Further, since numerous modifications and changes will readily occur to those skilled in the art, it is not desired to limit the invention to the exact construction and operation shown and described, and accordingly all suitable modifications and

3

equivalents may be resorted to, falling within the scope of the invention as claimed.

What is claimed as new is as follows:

1. A vehicle stepladder attachment comprising a pair of resiliently retractible, vertically extending telescoping tubular upper and lower supports having a pair of horizontally extending steps on the lower ends of said supports, said upper support being secured to and carried by a mounting plate by which said attachment is fastened to a vehicle in suspended vertical position, said supports being open at both ends of each and said lower supports being slidable within said upper support, spring means received within both of said supports and connected thereto at the opposite ends of said supports for yieldingly urging said supports into their telescoping retracted position, stop means carried by said supports for both preventing relative rotation and limiting vertical telescoping movement between said supports, said legs extending in opposite directions and longitudinally of the vehicle.

4

2. The combination of claim 1 wherein said spring means is connected to said supports by pins extending transversely of the supports and within the latter at the open upper and lower ends of said upper and lower supports respectively.

3. The combination of claim 2 wherein said stop means comprises a vertically extending slot in said lower support and an inwardly projecting member disposed within said upper support and slidably received in said slot.

References Cited in the file of this patent

UNITED STATES PATENTS

157,730	Washburn	Dec. 15, 1874
532,967	Kelley	Jan. 22, 1895
691,872	Rehkopf	Jan. 28, 1902
966,043	Nelson	Aug. 2, 1910
2,195,162	Baxter	Mar. 26, 1940