

(19) World Intellectual Property Organization
International Bureau



(43) International Publication Date
28 April 2011 (28.04.2011)

PCT

(10) International Publication Number
WO 2011/049591 A1

(51) International Patent Classification:
B65D 85/00 (2006.01)

(21) International Application Number:
PCT/US2010/001083

(22) International Filing Date:
12 April 2010 (12.04.2010)

(25) Filing Language: English

(26) Publication Language: English

(30) Priority Data:
12/589,210 20 October 2009 (20.10.2009) US
12/798,764 9 April 2010 (09.04.2010) US

(72) Inventor; and

(71) Applicant (for all designated States except US): **ZIEMBA, John, T.** [US/US]; 242 Central Avenue, Edison, NJ 08817 (US).

(74) Agents: **ZIEMBA, Jon, T.** et al.; Ernest D. Buff & Associates, LLC, 231 Somerville Road, Bedminster, NJ 07921 (US).

(81) Designated States (unless otherwise indicated, for every kind of national protection available): AE, AG, AL, AM, AO, AT, AU, AZ, BA, BB, BG, BH, BR, BW, BY, BZ, CA, CH, CL, CN, CO, CR, CU, CZ, DE, DK, DM, DO, DZ, EC, EE, EG, ES, FI, GB, GD, GE, GH, GM, GT, HN, HR, HU, ID, IL, IN, IS, JP, KE, KG, KM, KN, KP, KR, KZ, LA, LC, LK, LR, LS, LT, LU, LY, MA, MD, ME, MG, MK, MN, MW, MX, MY, MZ, NA, NG, NI, NO, NZ, OM, PE, PG, PH, PL, PT, RO, RS, RU, SC, SD, SE, SG, SK, SL, SM, ST, SV, SY, TH, TJ, TM, TN, TR, TT, TZ, UA, UG, US, UZ, VC, VN, ZA, ZM, ZW.

(84) Designated States (unless otherwise indicated, for every kind of regional protection available): ARIPO (BW, GH, GM, KE, LR, LS, MW, MZ, NA, SD, SL, SZ, TZ, UG, ZM, ZW), Eurasian (AM, AZ, BY, KG, KZ, MD, RU, TJ, TM), European (AT, BE, BG, CH, CY, CZ, DE, DK, EE, ES, FI, FR, GB, GR, HR, HU, IE, IS, IT, LT, LU, LV, MC, MK, MT, NL, NO, PL, PT, RO, SE, SI, SK, SM, TR), OAPI (BF, BJ, CF, CG, CI, CM, GA, GN, GQ, GW, ML, MR, NE, SN, TD, TG).

Published:

— with international search report (Art. 21(3))

(54) Title: COMPARTMENTALIZED PROTECTIVE CASE FOR PORTABLE HANDHELD ELECTRONIC DEVICES

Fig. 1

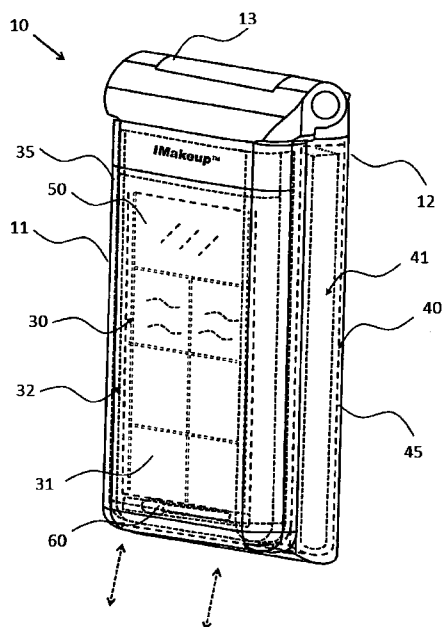

(57) Abstract: A compartmentalized protective case houses a portable electronic device and personal care items that are organized and held securely therewithin. The compartmentalized protective case has a major compartment for receiving and housing an electronic device such as a smart phone, cellular phone, music player, or other digital media device. At least one cell compartment constructed within the case receives and houses personal care items removably integrated therein. Personal care items can include at least one interchangeable replacement cell containing beauty items, cosmetics, hygienic items, oral care products such as floss or breath strips, medications, vitamins, breathe fresheners and / or health care products. A second cell compartment is preferably provided as a removable pouch or may contain a restraining system for holding identification cards, currency, visa or bank cards, and/or keys.

WO 2011/049591 A1

**COMPARTMENTALIZED PROTECTIVE CASE FOR PORTABLE
HANDHELD ELECTRONIC DEVICES**

CROSS-REFERENCE TO RELATED APPLICATIONS

5

This is a Continuation-In-Part of application Serial No. 12/589,210, filed October 20, 2009 for "COMPARTMENTALIZED PROTECTIVE CASE FOR PORTABLE HANDHELD ELECTRONIC DEVICE", the disclosure of which is hereby incorporated in its entirety by reference thereto.

10

BACKGROUND OF THE INVENTION

1. Field Of The Invention

The present invention relates to a compartmentalized protective case for portable handheld electronic devices; and, more particularly to a compartmentalized protective case including a primary compartment appointed for receiving a portable handheld electronic device and at least one cell compartment appointed for receiving at least one personal item such as one or more interchangeable replaceable cells, which may include beauty items, cosmetics, hygiene items, medications, vitamins, breathe fresheners and / or health care products. Preferably, the compartmentalized protective case also has a second cell compartment constructed as a removable pouch for holding identification cards, currency, visa or bank cards, and / or keys.

20

2. Description Of The Prior Art

Use of handheld electronic devices such as cell phones, smart phones, and media players has become extremely popular. Carrying handheld electronic devices, wallets, makeup, ID, health care products and other personal items on the person can become cumbersome. With the advent of consumers leaning toward sleeker, smaller and more compact handheld electronic devices such as cell phones, smart phones, and media players there is a need in the art for a sleek protective case that not only houses the device, but houses personal items, so that consumers do not need to carry

30

excessive accessories on their person. Carrying cases for these devices are currently provided as holster type devices and / or pouches which receive and house the electronic device. However, none of the heretofore disclosed and utilized devices provide a protective case having compartments for housing personal items for compact convenience.

Travel compacts for carrying and housing makeup products have been provided for; however these compacts are not constructed with a compartment for a handheld electronic device. For example: U.S. Patent No. 5,163,457 to Lombardi discloses a travel compact for housing a cosmetic supply and a mirror, both of which are encased by the compact in a storage mode. The supply and the mirror are both exposed in a utility mode whereby the user may then view her face as she applies the cosmetic thereto. U.S. Patent No. 5,353,947 to Zinnbauer et al. discloses a cosmetic case having a base and a cover releasably secured to one another; and Foreign Publication No. KR20080036823 to Bae et al. discloses a cosmetic case. These compacts and cases are constructed and function to merely provide a case for housing and carrying cosmetics, and do not provide a compact protective case for carrying a handheld electronic device.

Conversely, other devices only provide a holder for electronic devices. These other devices fail to provide a protective case and fail to provide a compartment housing beauty, health products or personal items in a compact integrated manner. For example: U.S. Patent No. 6,357,646 to Gur et al. discloses a holder for an article or mobile device that allows a device to be securely held in the holder while providing easy and flexible access to the personal device; U.S. Patent No. 7,077,596 to Bianco et al. discloses a two-way pocket assembly for use with a notebook constructed over a window formed in a subsurface material of the notebook; U.S. Patent No. 7,204,398 to Smith, Sr. discloses a multi-purpose wallet/cellular telephone case. This wallet/cellular telephone case includes a multi-sectional wallet unit having a central section and first, second, and third foldout sections that are integral with the central section; U.S. App. Pub. No. 2008/0149235 to Jay discloses a wallet having at least two surfaces defining an internal compartment; "Naztech The Voyage Cell Phone Case" by LTgear.com, found at http://www.ltgear.com/bags_cases.aspx?ID=3367

discloses a cell phone case that includes an area for storage of the cell phone and a separate bi-fold zip area for other personal items, such as keys, and the like; “V6075 All-N-One Cell Phone Case and Wallet” by Vitronicpromotional.com found at <http://www.vitronicpromotional.com/productdetail.aspx?id=V6075> discloses a cell phone case wallet; “Cell Phone Wallet” by Celi.com found at http://www.celicase.com/cell_phone_wallet.cfm discloses a cell phone wallet; “Sena Cases Iphone 3G and Iphone 3G S WalletBook Case – Red” by HandHeldItems.com found at <http://www.handhelditems.com/sena-cases-Iphone-walletbook-case-p-18159.html> discloses a smartphone wallet-book case. These wallet type / or bi-fold cases do not provide at least one cell having personal care items integrated therein for receiving cosmetics and / or beauty or personal care products, or health products, instead these constructs are merely bi-folds or wallet type structures.

Still other devices have been provided concerning cellular phones with personal items actually integrated within the body of the cellular phone itself. Unfortunately, integration within the phone renders the items un-removable from the phone, while rendering the items useless if they become exhausted or if the user wishes to change or upgrade the phone. Integration within the phone itself vastly limits the ability for a user to select his / her own personal products, while also limiting the ability for cellular phone selection. For example: U.S. Patent No. 6,424,823 to Moles discloses a cellular telephone comprising: 1) a handset case; 2) a display associated with the handset case capable of displaying alphanumeric characters when the cellular telephone is operated; and 3) a personal mirror associated with the cellular telephone. The cellular phone is taught to include a built-in personal mirror, but is not directed toward protective covers for cellular devices; U.S. Patent No. 6,788,919 to Watanabe which discloses a cellular phone including a cosmetics container integrated therein, attached in a back of the cellular phone body; U.S. Patent No. 7,146,184 to Tsitsiashvili discloses a personal communication and cosmetic storage device comprising a housing including personal communication circuitry having a first input portion and a second output portion pivotally connected to one another. At least one cosmetic storage layer is positioned within the first input layer for retaining and storing at least one type of cosmetic therein. The device is

selectively operable in a first mode as a personal communication device and, in a second mode upon accessing the at least one cosmetic storage layer, thereby allowing a user to access the stored cosmetic for application thereof. These cellular phones have integral cosmetic packs encompassed therein and do not teach a protective case for receiving a cellular telephone, or other handheld portable device, wherein the case includes a compartment for receiving a handheld electronic device and a second compartment appointed for receiving and housing at least one personal item.

Separate carries have been provided wherein a cosmetic carrier is appointed to be attached to a separate cell phone case. For example, U.S. Patent No. 7,431,161 to Carlino discloses a cosmetic carrier attachment for an electronic communications device that includes housing for retaining cosmetics and various configurations and elements for removably attaching the housing to the electronic communications device. The cosmetic carrier attachment includes a cosmetic case and means for attaching the cosmetic case to an electronic communications device. Appreciably, devices such as this provide a cosmetic carrier attachment including a cosmetic case and means for attaching the cosmetic case to an electronic communications device. The cosmetic carrier attachment is not a protective case for the electronic device, but instead is a cosmetic carrier that can be attached to the back of the electronic device. If the attachment becomes compromised, the device itself or the cosmetic carrier attachment could easily become lost.

Various purse – like devices have been provided that have the ability to hold a cellular phone and can receive items therein. However, these constructs are cumbersome in nature, and are not provided as a compact case. For example: U.S. Patent App. Pub. No. 2006/0112966 to Phue discloses a makeup case or kit comprising two hingedly connected compartments. A flat dividing element inserted between the compartments is hingedly held in place. A plurality of magnetic holders of the cosmetics supplies are removably insertable inside the first compartment; U.S. Patent App. Pub. No. 2008/0135144 to Brody discloses an adjustable size purse insert for easily transferring items from one purse to another. These devices are not protective, compact cases for a handheld electronic device, but are, instead, more like clutches or purses that are not small or compact in nature.

Even where cases have been provided which are appointed for housing personal electronic devices and personal items, these devices fail to provide integration of a plethora of personal items within a compartment in the case in a compact, organized, and replaceable manner. For example, U.S. App. Pub. No. 5 2009/0166247 to Gindi discloses a personal electronics device including a case having a first compartment and a second compartment. A series of integrated electronic components perform a desired personal electronic function wherein at least a portion of the components are housed in the first compartment. The second compartment defines a selectively accessible storage volume. A cosmetic tray is 10 housed in the accessible storage volume, and contains at least one form of cosmetic selected from the group of nail polish, mascara, eyeliner, lipstick, lip liner, and lip gloss. The cosmetic insert is slid out and removed when in use. It is not interstitially mounted in the case itself, but is received within a pocket / volume within the case. This is disadvantageous for at least two reasons. It would render the case less compact 15 in nature, and heightens chances that the cosmetic insert would fall out and / or become lost. Although the cosmetic tray is replaceable, there is no indication that the actual deposits are individually replaceable cells.

Notwithstanding the efforts of prior art workers to construct a compartmentalized protective case for portable handheld electronic devices, there is a 20 need in the art for a compact compartmentalized protective case for a personal electronic device that also compactly includes personal care products integrated therein. The compartmentalized protective case for portable handheld electronic devices should have appropriate apertures for connecting external speakers, wired head phones and hand held device charging connectors. The charging connects 25 typically comprise different configurations, such as a flat rectangular connector for Iphone devices or a USB connector for a blackberry device. In addition, there remains a need in the art for a compartmentalized protective case that includes a primary compartment appointed for receiving a portable handheld electronic device and at least one cell compartment appointed for receiving at least one personal item 30 that is preferably directed to a plurality of interchangeable replaceable cells including beauty items, cosmetics, hygiene items, medications, vitamins, breathe fresheners and

/ or health care products. There further exists a need in the art for a compartmentalized protective case wherein personal care items are provided in a plurality of replacement cells secured within a cell compartment within a case.

5

SUMMARY OF THE INVENTION

The present invention provides a compartmentalized protective case for housing a portable electronic device and personal care items that are organized and securely held within the case. The compartmentalized protective case has a major compartment appointed to receive and house an electronic device such as a smart
10 phone, cellular phone, music player, or other digital media device. At least one cell compartment is constructed within the case with means for receiving and housing personal care items removably integrated therein. Preferably the personal care items are provided as a plurality of interchangeable replacement cells including beauty items, cosmetics, hygienic items, oral care products such as floss or breath strips,
15 medications, vitamins, breathe fresheners and / or health care products. Preferably, a second cell compartment is provided that is constructed as a removable pouch or restraining system, for holding identification cards, currency, visa or bank cards, and / or keys.

Carrying electronic devices, wallets, makeup, ID and other personal items on
20 the person can become cumbersome. With the advent of consumers leaning toward sleeking, smaller and more compact handheld electronic devices such as cell phones, smart phones, and media players there is a need in the art for a sleek protective case that not only houses the device, but houses personal items. In this manner, consumers do not need to carry excessive accessories on their person. None of the heretofore
25 disclosed and utilized cases for these devices provide compartments for housing personal items for compact convenience. Further none of the heretofore known devices include a compartment for housing makeup products.

Uniquely, the compartmentalized protective case herein provides a compact
30 compartmentalized protective case appointed to house an electronic device as well as personal items. Personal items intended for storage in the compartmentalized protective case may include identification, keys, money, business cards, makeup (such

as eye makeup, lip gloss, powder, foundation, and applicators thereof) beauty products in general, oral health care products, health products, medication, vitamins, hand sanitizer, lotions, anti-wrinkle creams and serums, a note pad, and/ or other personal items.

5 Generally stated, the compartmentalized protective case is preferably constructed from a polymeric material forming a rigid protective case body. In one embodiment the case is constructed having a major compartment appointed for receiving and housing an electronic device and a cell compartment appointed for receiving and housing personal care items removably integrated therein.

10 Electronic devices appointed to be received in the case include cell phones, smart phones, media players and music player devices. Preferably the personal care items are presented as a plurality of replacement/ replaceable cells that carry personal items therein. The major/ primary and / cell compartment may include a cover which hingedly operates to open and close to allow access to the compartment. The

15 compartmentalized protective case may have geometrically shaped apertures suitable for attachment of external speakers, wired headphones camera operation and the like while said portable device contained within the protective case. The compartmentalized protective case may also include suitably shaped apertures for inserting charging wired connectors for iPhones

20 or blackberry devices. Alternatively, the primary and/ cell compartments are enclosed with sliding covers. What is more, a mirror or reflective material may be included within the cell compartment or on the cell compartment or major compartment covers so that a user to view herself/ himself. An opening appointed to receive a wristlet attachment, or at least two parallel openings may be integrated

25 within the case appointed to receive a strap or chain attachment so that the case resembles a small clutch.

 Preferably, the cell compartment includes internal attachment means and the personal care items are integrated within replaceable cells including cell attachment means in mating communication for interchangeability and securing the replaceable

30 cells within the cell compartment. These personal items may comprise a mini-makeup kit including internal attachment means for securing a plurality of makeup

cells (replacement cells) having mating cell attachment means. The mini-makeup kit preferably includes internal attachment means and the makeup cells include cell attachment means in mating communication for securing the plurality of makeup cells, wherein the makeup cells are replaceable cells removable from the mini-makeup kit for unique selection and interchangeability of the makeup cells. The internal attachment means preferably comprises grooves/ rails and the mating cell attachment means comprise rails/ grooves so that the makeup cells are slidably secured within the mini-makeup kit. The internal attachment means may instead comprise low bond adhesive, mating clip, magnetic portions, or hook and loop fasteners mechanisms such as those sold under the trade name VELCRO. The makeup cells may include a plethora of beauty supplies, for example, the makeup cells may include items selected from a group consisting of foundation, concealed, lipstick, lip gloss, eye shadow, eye liner, mascara and blush and / or combinations thereof. What is more, at least one applicator may be provided for applying the makeup products.

Alternatively, the personal care items may comprise a mini- health care product kit. The mini-health care product kit in turn may include oral hygienic items comprising dental floss. For example a replaceable floss wheel with a typical cutting portion may be provided, such as those currently sold, but in a smaller configuration so as to fit within the compact case. Conversely, instead of a floss wheel, floss pieces may simply be provided as precut floss pieces having a length ranging between two to four inches. Optionally, the mini-health care product kit may be made-up of hygienic items consisting of lotions, serums, sun screens and anti-aging creams. In this manner the cells are provided as shallow trays wherein the lotion or serums are injected into the trays and allowed to set for packaging. Other personal care items may be provided including a mini-health care product kit comprising items such as breath strips, breath mints, gum, and candies. Still alternatively, the optional mini-health care product kit may include cells for pill medication, cold medication, vitamins, eye drops, ointment, adhesive strips for cuts, bandages and hand sanitizers.

A second cell compartment may be provided that is either integrated within the case or provided as a removable pouch removably attached to the case. The pouch may be attached by way of hook and loop fasteners, such as those sold under the trade

name VELCRO, or by way of magnetic attachment to the case. Instead of a pouch, the optional third cell compartment may be constructed as a restraining system, preferably a netted restraining system, wherein the netting is integrated within the case and provides shallow depth containment for holding identification cards, currency, keys, or other shallow depth items.

A method of using a compartmentalized protective case for a portable electronic device is provided. The method comprises the steps of: (a) inserting the portable electronic device into a major compartment of the compartmentalized protective case; (b) selecting personal care items comprising a plurality of replaceable cells; (c) inserting the selected replaceable cells within a cell compartment of the compartmentalized protective case, the cell compartment having internal attachment means and the replaceable cells including cell attachment means in mating communication for interchangeability and securing the replaceable cells within the cell compartment; and (d) replacing and interchanging the selected replaceable cells as desired or as the selected replaceable cells become used-up or depleted.

BRIEF DESCRIPTION OF THE DRAWING

The invention will be more fully understood and further advantages will become apparent when reference is had to the following detailed description of the preferred embodiments of the invention and the accompanying drawings, in which:

FIG. 1 illustrates a first embodiment of the compartmentalized protective case shown in the assembled, closed view;

FIG. 2 illustrates the embodiment of the cell compartment and closure lid with replaceable cells of FIG. 1 in a disassembled view;

FIG. 3a illustrates a schematic view of the cell compartment of FIG. 2;

FIG. 3b illustrates a cross-sectional side view of the cell compartment of FIG. 3a;

FIG. 3c illustrates a top view of a replacement cell;

FIG. 3d illustrates a cross-sectional side view of the replacement cell;

FIG. 4a illustrates a side-sectional view of the top portion of the case shown in FIG. 1;

FIG. 4b illustrates a top-sectional view of the top portion of the case shown in FIG. 1;

5 **FIG. 4c** illustrates a top-sectional view of the top portion of the case shown in FIG. 1;

FIG. 5a illustrates a sectional view of the top of the cell compartment of the case shown in FIG. 1;

10 **FIG. 5b** illustrates a top planer view of the top portion of the cell compartment of the case shown in FIG. 1;

FIG. 5c illustrates a side view of the cell compartment of the case shown in FIG. 1;

FIG. 6a illustrates a sectional view of the top of the major / primary compartment of the case shown in FIG. 1;

15 **FIG. 6b** illustrates a top planer view of the major / primary compartment of the case shown in FIG. 1;

FIG. 6c illustrates a side view of the major / primary compartment of the case shown in FIG. 1;

20 **FIG. 7** illustrates a top view of the major / primary compartment of the case shown in FIG. 1;

FIG. 8a illustrates an embodiment of the compartmentalized protective case wherein a second cell compartment is provided for housing an identification, currency and / or a key;

FIG. 8b illustrates removable attachment of the second cell compartment;

25 **FIG. 8c** illustrates the cell compartment in an open condition;

FIG. 8c illustrates the cell compartment showing insertion of a makeup kit;

FIG. 9a illustrates a schematic view of an embodiment of the compartmentalized protective case;

FIG. 9b illustrates a cross-sectional view taken along line x—x;

30 **FIG. 9a** illustrates a schematic view of an embodiment of the compartmentalized protective case;

FIG. 10a illustrates a schematic view of an embodiment of the compartmentalized protective case;

FIG. 10b illustrates a view of an optional second cell compartment in the open configuration;

5 **FIG. 11a** illustrates a front view of an embodiment of the compartmentalized protective case appointed with a hand strap / wristlet attachment;

FIG. 11b illustrates a back view;

FIG. 12a illustrates a front view of an embodiment of the compartmentalized protective case appointed with a strap attachment;

10 **FIG. 12b** illustrates a back view;

FIG. 13 illustrates a closed protective case for an Iphone showing its top surface;

FIG. 14 illustrates a closed protective case for an Iphone showing its bottom surface;

15 **FIG. 15** illustrates an opened protective case for an Iphone;

FIG. 16 illustrates a top view of an opened protective case for an Iphone when the lid is flipped by 360° at the hinge exposing the front surface of the Iphone;

FIG. 17 illustrates the closed protective case for an Iphone showing its top lid covering the Iphone;

20 **FIG. 18** illustrates a top view of a closed protective case with the top slider opened to access storage compartments.

DETAILED DESCRIPTION OF THE INVENTION

25 The present invention is directed to a compartmentalized protective case for housing a portable electronic device and personal care items that are organized and held securely within the case. The compartmentalized protective case is constructed having a major compartment appointed for receiving and housing a handheld electronic device such as a smart phone, cellular phone, music player, or
30 other digital media device. At least one cell compartment is constructed within the case that is appointed for receiving and housing personal care items removably

integrated therein. Preferably the personal care items are provided as a plurality of interchangeable replacement cells including beauty items, cosmetics, hygienic items, oral care products such as floss or breath strips, medications, vitamins, breathe fresheners and / or health care products. A second cell compartment may be provided
5 that is constructed as a removable pouch or restraining system for holding identification cards, currency, visa or bank cards, and / or keys. In an alternative embodiment, the cell can be a well or deep pocket adapted to hold items such as a condom, key, identification cards, credit cards or money.

The compartmentalized protective case is appointed to house an electronic
10 device such as cell phones and / or smart phones such as those sold under the trade names Iphone® and Blackberry®, media players such as those sold under the trade name iPod®, and any other electronic devices. The protective case is preferably constructed of a durable material forming a shell so as to provide protection to the electronic device housed therein, including a polymeric, lightweight metal, rubber,
15 silicone material and / or combinations thereof. Alternatively, the protective case may be constructed using less rigid materials, such as canvas, fibers and / or combinations thereof.

Fig. 1 illustrates a first embodiment of the compartmentalized protective case shown in the assembled, closed view, shown generally at 10. Compartmentalized
20 protective case 10 is constructed having a front side 11, back side 12, top 13, major compartment 40 and at least one cell compartment 30. Major compartment 40 is appointed for receiving and housing an electronic device 41, including hand held electronic devices such as cell phones and / or smart phones, including those sold under the trade names Iphone® and Blackberry®, media players such as those sold
25 under the trade name iPod®, personal video game devices and any other handheld electronic devices. At least one cell compartment 30 is provided that is appointed for receiving and housing personal care items removably integrated therein. The cell compartment 30 is preferably provided with shallow side walls so that the compartment 30 is compact in nature. Preferably the personal care items are
30 presented as a plurality of replacement / replaceable cells 31 that carry personal items therein. The major / primary 40 and / cell compartment 30 each include a cover 45,

35 which hingedly operates to open and close to allow access to the respective compartment 40, 30. Alternatively, the primary 40 and / cell compartment 30 are enclosed with sliding covers 45, 35, or combinations thereof. In the embodiment shown, cover 35 is a sliding cover as illustrated in Figure 2. A mirror 50 or reflective material may be included within the cell compartment or on the cell compartment 30 as shown, or it may be located in the major compartment 40 so that a user to view herself / himself.

The cell compartment 30 preferably includes internal attachment means and the personal care items are integrated within replaceable cells 31 including cell attachment means in mating communication for interchangeability and securing the replaceable cells within the cell compartment 30. Personal items may comprise a mini-makeup kit 32 including internal attachment means for securing a plurality of makeup cells (replacement cells) having mating cell attachment means as shown. The mini-makeup kit 32 preferably includes internal attachment means and the makeup cells 31 include cell attachment means in mating communication for securing the plurality of makeup cells 31. The makeup cells 31 may include a plethora of beauty supplies and may be readily mixed and matched depending on the user's needs, for example, the makeup cells may include items selected from a group consisting of foundation, concealed, lipstick, lip gloss, eye shadow, eye liner, mascara and blush and / or combinations thereof. At least one applicator 60 may be provided for applying the makeup products.

Alternatively, the personal care items may comprise a mini- health care product kit. The mini-health care product kit in turn may include oral hygienic items comprising dental floss. For example a replaceable floss wheel with a typical cutting portion may be provided, such as those currently sold, but in smaller configuration so as to fit within the compact case. Conversely, instead of a floss wheel, floss pieces may simply be provided as precut floss pieces having a length ranging between two to four inches. Optionally, the mini-health care product kit may be made-up of hygienic items consisting of lotions, serums, sun screens and anti-aging creams. In this manner the cells are provided as shallow trays wherein the lotion or serums are injected into the trays and allowed to set for packaging. Other personal care items may be

provided including a mini-health care product kit comprising items such as breath strips, breath mints, gum, and candies. Still alternatively, the optional mini-health care product kit may include cells for pill medication, cold medication, vitamins, eye drops, ointment, adhesive strips for cuts, bandages and hand sanitizer.

5 Figs. 2 and 3a – 3d illustrate the embodiment of the cell compartment and closure lid with replaceable cells of Fig. 1 in a disassembled view. Referring to Figs. 2 and 3a – 3d, cell compartment 30 is shown disassembled. Cell compartment 30 is appointed for receiving and housing personal care items removably integrated therein, preferably constructed as a plurality of replacement / replaceable cells 31 that carry
10 personal items therein. Cell compartment 30 includes a cover 35 which, in this embodiment, is slideably mounted on cell compartment 30. Cell compartment 30 includes internal attachment means herein shown as tracks / rails including side rails 231a and a center rail 231b that mate with replacement cells 31 by way of communication with mating cell attachment means 234 provided as corresponding
15 grooves 235 adapted to receive rails 231a, 231b. In this manner, replacement cells 31 are slid onto and mounted within cell compartment 30 so that the cells 31 do not fall from the device when cover 35 is slid open. This also prevents the cells 31 from shifting around within compartment 30. Alternatively, the internal attachment means may instead comprise low bond adhesive, mating clip, magnetic portions, or hook and
20 loop fasteners mechanisms such as those sold under the trade name VELCRO. For sliding of cover 35, cell compartment 30 further includes outer rails 236 appointed to mate with corresponding grooves 237 located on walls 238 of cover 35.

Figs. 4a – 4c illustrate views of the top portion 13 of the device which is constructed to provide slidability of the compartments and / or rotation and
25 pivoting of the covers to access the compartments. Particularly, Fig. 4a illustrates a side-sectional view of the top portion of the case shown in Fig. 1; Fig. 4b illustrates a top-sectional view of the top portion of the case shown in Fig. 1; and Fig. 4c illustrates a top-sectional view of the top portion of the case shown in Fig. 1. Figs. 5a – 5c illustrate view of the cell compartment. Figs. 6a – 6c illustrate a
30 sectional view of the top of the major / primary compartment of the case. Fig. 7

illustrates a top view of the major / primary compartment of the case shown in Figs. 6a – 6c.

Figs 8a – 8d illustrate the compartmentalized protective case having a second cell compartment, and with the case in the open configurations (Figures 8a and 8b show a second cell compartment and the major compartment while Figures 8c and 8d show the cell compartment); and Figures 9a and 9b illustrate the compartmentalized protective case schematically illustrated in Figures 8a – 8d, however shown in the closed condition, depicting a top plane view and a cross-sectional view taken along line x—x. Compartmentalized protective case 8110 comprises a major compartment 8140 appointed for receiving and housing a handheld electronic device, herein shown as a smart phone 8141. As discussed hereinabove, the handheld electronic device can be a plethora of different heretofore known or otherwise later invented handheld electronic devices. Compartmentalized protective case 8110 further comprises at least one cell compartment appointed for receiving and housing at least one personal item, herein case 8110 includes two cell compartments hereinafter referred to as a first cell compartment 8120 and a second cell compartment 8130 preferably piggybacked upon one another, both of which are shown in the open configuration in Figures 8a – 8d and in the closed configuration in Figures 9a and 9b.

Cell compartments 8120, 8130 are enclosed with either a hinge or sliding cover. Cell compartments 8120, 8130 form containments for receiving replaceable cells 8121, 8131 held in place with adhesives, magnets, mechanical or adhesive means (such as hook and loop fasteners) so that the cells 8121, 8131 enclosed within the cell compartments 8120, 8130 can be replaced and visa via the personal care products integrated within the cells are replaceable. Cell 8131 includes individually replaceable components / personal care items. Herein, the replaceable cell 8131 comprises a mini-makeup kit 8132. The mini-makeup kit 8132 includes a mirror 8133, eye makeup 8134, eyeliner 8135 and an applicator 8136, for example. These personal care products are replaceable components within cell 8131. The mirror 8133, applicators 8136, each individual lip gloss color / eye makeup 8124, etc., are each individual personal care product cells that can be replaced in different configurations. This way each person can setup their own personalized personal care

kit to carry exactly what they want, when they want. All replaceable parts (parts 8133-8135) can be popped in and out of the compartment 8130. This would include any part used as a tray to secure the personal care products. Replaceable cells 8133-8135 may include a plethora of personal items including a plethora of different health care items, oral hygienic items, beauty supplies such as eye makeup, lip gloss, powder, concealer, foundation, blush, and / or combinations thereof so that a user can refresh her look throughout the day or evening.

Preferably second cell compartment 8120 is appointed to receive a replaceable cell 8121 which comprises a pouch 8122 that is held in place within the first cell compartment 8120 with a magnet, hook and loop fasteners (such as that sold under the trade name VELCRO) or adhesive. Pouch 8122 is adapted to receive and house personal items such as identification cards (ID), credit cards, bank cards, currency, keys, business cards, etc. As shown in Figure 8b, replaceable cell 8121 comprising pouch 8122 is received within first cell compartment 8120.

Figs 9a and 9b show a top plane view and a cross-sectional view taken along line x—x. Compartmentalized protective case 8110 comprises a major compartment 8140 appointed for receiving and housing handheld electronic device, smart phone 8141. Compartmentalized protective case 8110 further comprises two cell compartments 8120 and 8130, both of which are shown in the closed configuration herein. Cell compartments 8120, 8130 are enclosed with either a hinge or sliding cover. Cell compartments 8120, 8130 form containments for receiving replaceable cells 8121, 8131 that can be replaced and / or include replaceable cells or compartments therein for personal care products. Second cell compartment 8120 is appointed to receive a replaceable cell 8121 which comprises a pouch 8122 adapted to receive and house personal items such as identification cards (ID), credit cards, bank cards, currency, keys, business cards, etc. First cell compartment 8130 is appointed to receive replaceable cell 8131 which comprises a mini-makeup kit 8132. Second cell compartment 8120 is preferably located on the top side of the case, just under the first cell compartment 8130 storing the personal care items. Second cell compartment 8120 is preferably hinged and opens to reveal the face of the electronic device 8141. Both the wallet portion (second cell compartment 8120), and the personal care item storage

compartments (first cell compartment 8130) are contained in the top side of the case 8110. (This will allow a variety of back plate styles to be sold to the consumer).

Figs 10a and 10b illustrate another embodiment of the compartmentalized protective case, shown generally at 1000. Compartmentalized protective case 1010
5 comprises a major compartment 1040 appointed for receiving and housing a handheld electronic device, herein shown as a smart phone 1041. Compartmentalized protective case 1010 further comprises at least one cell compartment appointed for receiving and housing at least one personal item, herein case 1010 includes two cell compartments hereinafter referred to as a second cell compartment 1020 and a first
10 cell compartment 1030 preferably piggybacked upon one another, both of which are shown in the open configuration in Figures 10a and 10b, respectively. Cell 1020 is herein shown flipped open via pivoting motion from the major compartment 1040, and includes a pouch for housing an ID or the like. Cell 1030 includes a slidable cell cover 1031 that is slidably mounted on cell 1020, and is best illustrated in Figure
15 10b.

Preferably, cell 1030 comprises grooves 1051 for mating with rails 1052 integrated within side edges of the rear of cell compartment 1020 so that cell cover 1031 slides open and shut. Secondary rails 1041 are integrated within cell compartment 1030 appointed for mating with secondary grooves 1042
20 correspondingly integrated on the backside of individual replaceable cells 1061 including cosmetics integrated therein, forming a mini-makeup kit 1032. In this manner, individual replaceable cells 1061 can be readily interchanged and a user can select her unique color palette or cosmetic needs. Further, a mirror 1033 is slidably mounted on the secondary rails 1041. These individual replaceable cells 1061 are
25 replaceable components and may include lip gloss color / eye makeup, powder, concealer, foundation, blush, and / or combinations thereof so that a user can refresh her look throughout the day or evening.

Figs. 11a and 11b illustrate overviews of an embodiment of the compartmentalized protective case with a hand strap / wristlet attachment; Figures
30 12a and 12b illustrate overviews of the compartmentalized protective case with a larger strap / clutch type of strap attachment. In referring to Figs. 11a and 11b and

Figs. 12a and 12b, the compartmentalized protective case 1110 includes a front side 1111 and a back side 1112, a primary compartment 1140 and a cell compartment 1120. The case 1110 as shown in Figures 11a, 11b, 12a and 12b, is in the closed condition. The case 1110 in Figures 11a and 11b includes an opening 1113a appointed to receive a wristlet attachment 1113 for portability. The case 1110 in
5 Figures 12a and 12b includes at least two parallel openings 1116a appointed to receive a strap or chain attachment 1116 for portability via optional clutch strap attachment means 1117 integrated within the front side 1111 of case 1110.

In a first embodiment, the compartmentalized protective case comprises: (i) a
10 major compartment appointed for receiving and housing a handheld electronic device; and (ii) at least one cell compartment appointed for receiving and housing at least one personal item. The personal care item can comprises a cosmetic panel. It can alternatively comprise a deep well adapted to receive such items as condoms, keys identifications cards, credit cards or money. Preferably, the personal care panel
15 comprises at least one individual interchangeable personal care component, such as eye shadow, lipstick, pressed powder, a mirror, applicators, eye pencils, lip pencils. The individual components may be popped out of the cell compartment and replaced with another component.

In a second embodiment, the compartmentalized protective case comprises:
20 (i) a major compartment appointed for receiving and housing a handheld electronic device; (ii) at least one cell compartment appointed for receiving and housing at least one cosmetic panel; and (iii) at least one cell compartment appointed for receiving and housing an identification card or ID. Preferably, the ID cell compartment is a removable pouch, sleek in nature, and appointed to be released from the case.
25 Alternatively, the ID cell compartment is a sleek shallow segment which comprises a part of the case itself, or which is adapted to pivot from the case, or alternatively to slide from the case.

Fig. 13 illustrates at 130 the closed protective case for an Iphone showing its top lid 131 which has a fully customizable slide cover and the
30 details of which is shown in Fig. 18. The connection to a speaker or charger is shown at 132. The Iphone has a height of 4.5" (115.5 mm), width of 2.4" (62.1 mm)

and a depth of 0.48" (12.3 mm) and the protective case accommodates these dimensions as shown in the subsequent figures.

FIG. 14 illustrates at 140 the closed protective case for an Iphone showing its bottom surface 141. The aperture for admitting light to the camera of the cell phone is shown at 142. The speaker/ charger connection location is shown at 132. The hinge between the bottom cover and the top cover is shown at 143 and the top cover may be flipped 360° as shown in Fig. 16. The two raised portions 143 on the left side of the case, respectively, are attachments, which can be used to secure a chain or strap for carrying the protective case about the wrist or otherwise.

FIG. 15 illustrates at 150 the opened protective case for an Iphone. The top lid 131 is shown in the opened position. The Iphone is shown at 152. The hinged portion is shown at 143. The space between the locking ID card holder 151 and the top lid 131 can hold credit card and the like.

FIG. 16 illustrates at 160 the top view of an opened protective case for an Iphone when the top lid 131 is flipped by 360° at the hinge 143, exposing the front surface of the Iphone 152. The camera light-admitting aperture is directly below the Iphone ready to take photographs.

FIG. 17 illustrates at 170 the closed protective case for an Iphone showing its top lid 130 covering the Iphone. The top lid 130 slider is in the closed position in this figure.

FIG. 18 illustrates at 180 the top view of a closed protective case with the top slider 130 opened to access storage compartments 180a, 180b and 180c. These compartments can store various personal items. The elongated groove 182 on the right side of the case adjacent to the cell compartments 181a, 181b and 181c is used to store a pencil, applicator, or device. The flat portion 183 to the right of the elongated groove is used to facilitate removal of the pencil, applicator, or device. The user places a thumb or forefinger along the flat portion to obtain improved leverage when removing the pencil. The opening on the case 184 is used to facilitate removal of the replaceable

cells. The three raised portions 185 to either side at the end of the slidable member 131 are used facilitate user grip when sliding the member 131. In addition, a plurality of knobs 186 in the case interface and lock with the interior of the slideable member 131 to hold the slideable member in place
5 when moved to the closed position.

Key features of the compartmentalized protective case for a portable electronic device and method may include:

1. a protective case for portable electronic devices, such as cell phones, smart phones, iPhones®, iPods®, Blackberry® devices, media players, etc;
- 10 2. providing compartments that contain personal care products integrated therein, and/ or applicators;
3. the personal care products are contained in replaceable cells or a non-replaceable compartment;
4. the replaceable cells can be held in place with adhesives, clips,
15 magnets, mechanically, or by materials that create adhesion;
5. compartments are enclosed with either a hinged or sliding cover;
6. one or more compartments can hold a mirror or reflective material;
7. a replaceable pouch or restraining system may be integrated within the case appointed for use with a wallet or storage for an ID, credit cards, money, a key,
20 or the like;
8. the replaceable pouch may be held in place with adhesives or hook and loop fasteners;
9. an opening on the body of the case may be provided to attach a wristlet;
- 25 10. a parallel openings on the body of the case may be provided to attach a strap or chain.
11. An Iphone having a compartmentalized protective case that has a plurality of apertures for admitting light to a camera, apertures for connection to speakers or chargers and apertures for connection to wired headphones and access to
30 various controls of the Iphone. The top lid of the protective case is hinged to flip 360° to access functionality of the Iphone.

The compartmentalized protective case and method of use disclosed herein can be modified in numerous ways without departing from the scope of the invention. For example, different materials or attachment fasteners and a variety of personal products may be used. These and other modifications are
5 intended to fall within the scope of the invention, as defined by the subjoined claims.

Having thus described the invention in rather full detail, it will be understood that such detail need not be strictly adhered to, but that additional changes and modifications may suggest themselves to one skilled in the art,
10 all falling within the scope of the invention as defined by the subjoined claims.

CLAIMS

What is claimed is:

1. A compartmentalized protective case for a portable electronic device,
5 comprising:
 - a. a major compartment appointed for receiving and housing an electronic device; and
 - b. at least one cell compartment appointed for receiving and housing personal care items integrated therein
 - 10 c. said compartmentalized protective case having an plurality of apertures for various electronic connections and access to functional controls of the said electronic device.
2. A compartmentalized protective case as recited by claim 1, wherein said personal care items comprise internal attachment means for securing a plurality
15 of cells having mating cell attachment means.
3. A compartmentalized protective case as recited by claim 1, wherein said compartments may be exily removed using an opening at the top of the protective case.
4. A compartmentalized protective case as recited by claim 2, wherein said internal
20 attachment means and said cells include cell attachment means in mating communication for securing said plurality of cells, wherein said cells are replaceable cells removable from case for unique selection and interchangeability of said cells.
5. A compartmentalized protective case as recited by claim 3, wherein said internal
25 attachment means comprises grooves/ rails and said mating cell attachment means comprises rails / grooves so that said cells are slidably secured within said case.
6. A compartmentalized protective case as recited by claim 3, wherein said internal
30 attachment means comprise low bond adhesive, mating clip, magnetic portions, or hook and loop fasteners mechanisms.

7. A compartmentalized protective case as recited by claim 3, wherein said makeup cells are selected from a group consisting of foundation, concealer, lipstick, lip gloss, eye shadow, eye liner, mascara and blush and/ or combinations thereof.
- 5 8. A compartmentalized protective case as recited by claim 1, wherein said personal care items comprise a mini- health care product kit.
9. A compartmentalized protective case as recited by claim 8, wherein said mini-health care product kit comprises oral hygienic items comprising dental floss.
- 10 10. A compartmentalized protective case as recited by claim 8, wherein said mini-health care product kit comprises hygienic items selected from the group consisting of lotions, serums, sun screens and anti-aging creams.
11. A compartmentalized protective case as recited by claim 8, wherein said mini-health care product kit comprises items selected from the group consisting of breath strips, breathe mints, gum, and candies.
- 15 12. A compartmentalized protective case as recited by claim 8, wherein said mini-health care product kit comprises items selected from the group consisting of pill medication, cold medication, vitamins, eye drops, ointments, adhesive strips for cuts, bandages and hand sanitizer.
13. A compartmentalized protective case as recited by claim 1, wherein an elongated groove is provided on the right side of the compartments to store a pencil, applicator, or device.
- 20 14. A compartmentalized protective case as recited by claim 13, wherein a flat portion adjacent to said elongated groove facilitates removal of the pencil, applicator, or device.
- 25 15. A compartmentalized protective case as recited by claim 1 comprising at least one applicator.
16. A compartmentalized protective case as recited by claim 1 comprising a second cell compartment.
- 30 17. A compartmentalized protective case as recited by claim 16, wherein said second cell compartment is a removable pouch and/ or a clip.

18. A compartmentalized protective case as recited by claim 16, wherein said second cell compartment is a restraining system.
19. A compartmentalized protective case as recited by claim 1, wherein said electronic device is a handheld device selected from the group consisting of a
5 cell phone, smart phone, media player and music player device.
20. A compartmentalized protective case as recited by claim 1, wherein said electronic device is a Iphone.
21. A compartmentalized protective case as recited by claim 1, wherein said protective case has apertures for admitting light to a camera, aperture for
10 connecting external speakers to an Iphone, aperture for connecting a charger and aperture for connecting wired headphone.
22. A compartmentalized protective case as recited by claim 1, wherein said primary and/ cell compartment is enclosed with a hinged cover.
23. A compartmentalized protective case as recited by claim 1, wherein said
15 primary and/ cell compartment is enclosed with a sliding cover.
24. A compartmentalized protective case as recited by claim 23, wherein said sliding cover is held in place by restraining bumps when in the closed position.
25. A compartmentalized protective case as recited by claim 23, wherein the sliding
20 cover has raised portions to facilitate the grip of the user during sliding of the cover.
26. A compartmentalized protective case as recited by claim 1, wherein said primary and/ cell compartment is enclosed with a hinged sliding cover.
27. A compartmentalized protective case as recited by claim 1 comprising a mirror or reflective material.
- 25 28. A compartmentalized protective case as recited by claim 1 comprising an opening appointed to receive a wristlet attachment.
29. A compartmentalized protective case as recited by claim 1 comprising at least two parallel openings or attachments appointed to receive a securing strap or chain.
- 30 30. A compartmentalized protective case as recited by claim 1, wherein said cell compartment includes internal attachment means and said personal care items

are integrated within replaceable cells including cell attachment means in mating communication for interchangeability and securing said replaceable cells within said cell compartment.

31. A method of using a compartmentalized protective case for a portable
5 electronic device, comprising the steps of:
- a. inserting said portable handheld electronic device into a major compartment of said compartmentalized protective case;
 - b. selecting personal care items comprising a plurality of replaceable
10 cells;
 - c. inserting said selected replaceable cells within a cell compartment of said compartmentalized protective case, said cell compartment having internal attachment means and said replaceable cells including cell attachment means in mating communication for interchangeability and securing said replaceable cells within said cell compartment;
 - 15 d. replacing and interchanging said selected replaceable cells as desired or as of said selected replaceable cells become used-up or depleted.

Fig. 1

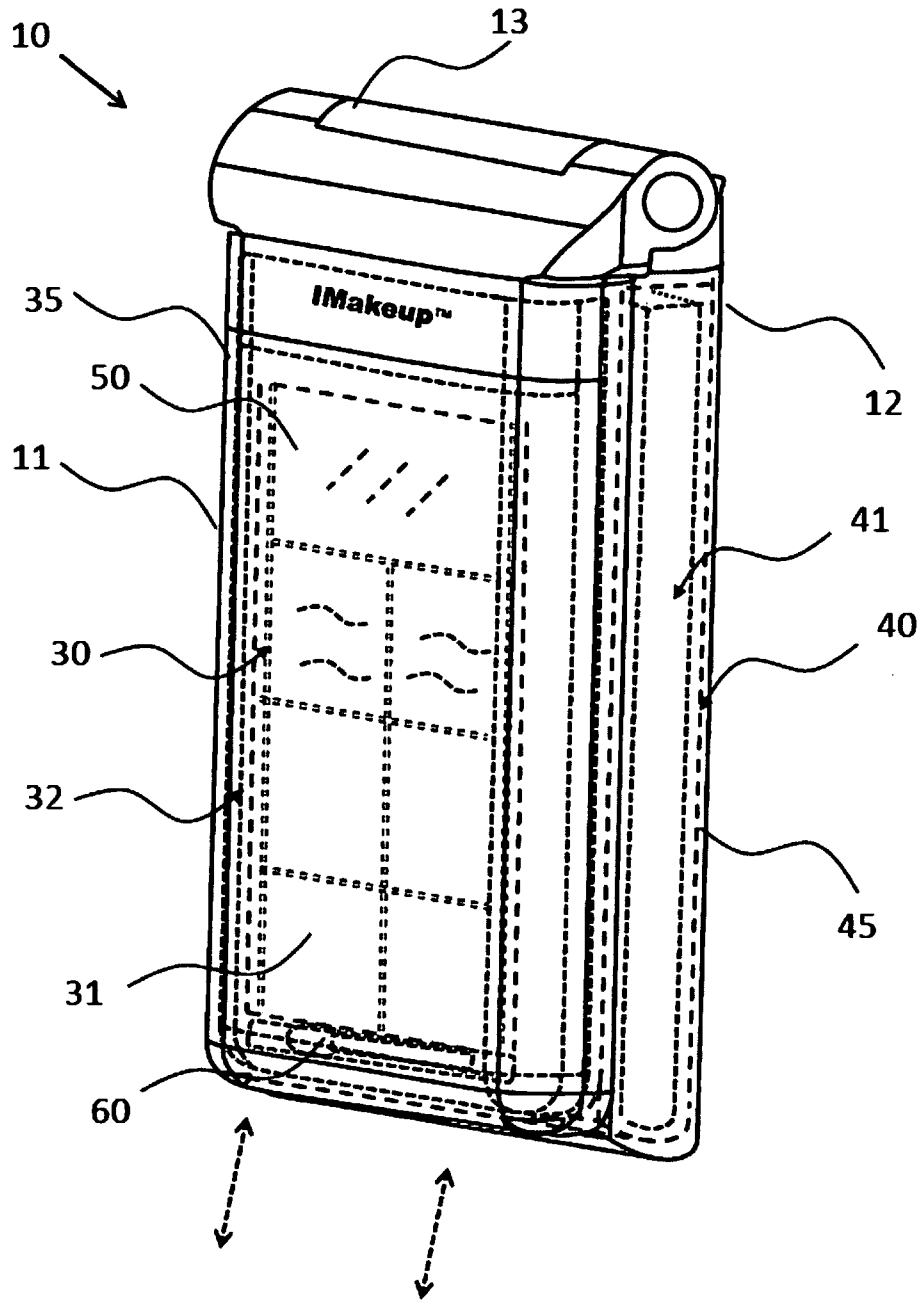

Fig. 2

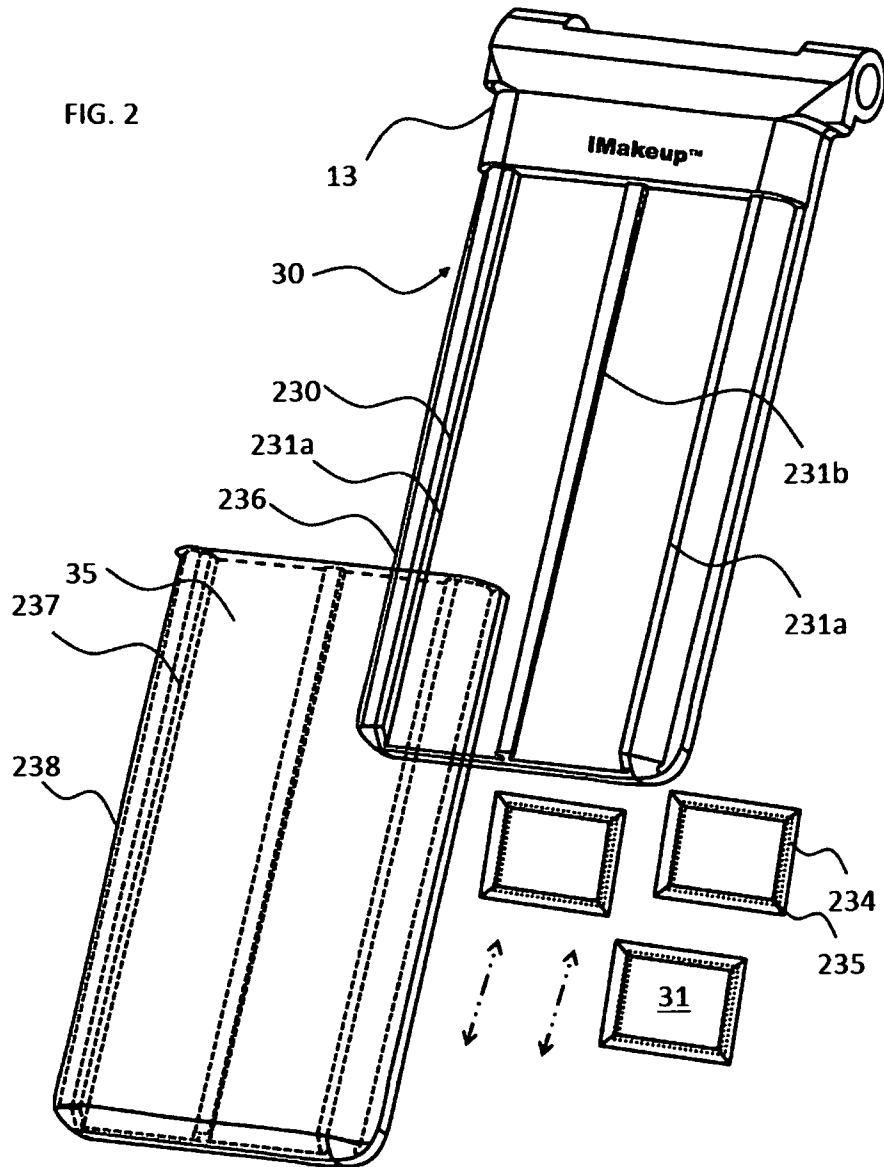

Fig. 3a

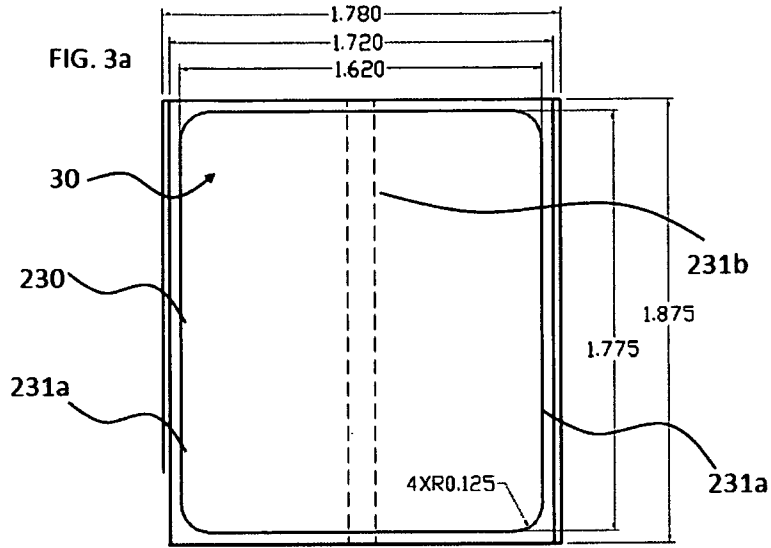

Fig. 3b

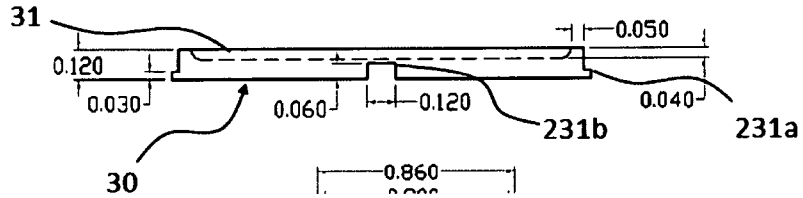

Fig. 3c

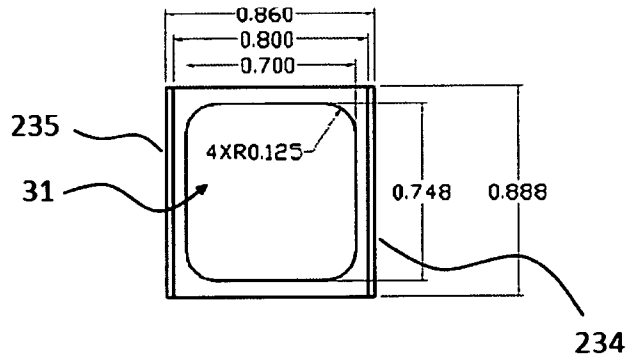

Fig. 3d

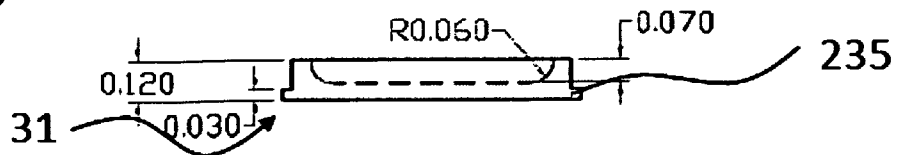

Fig. 4a

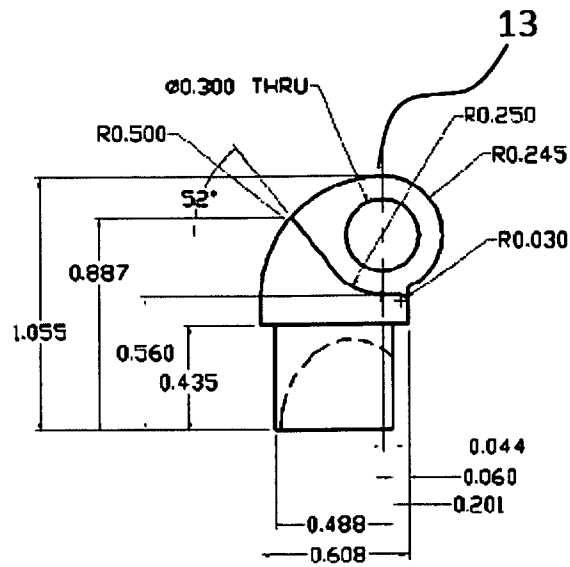

Fig. 4b

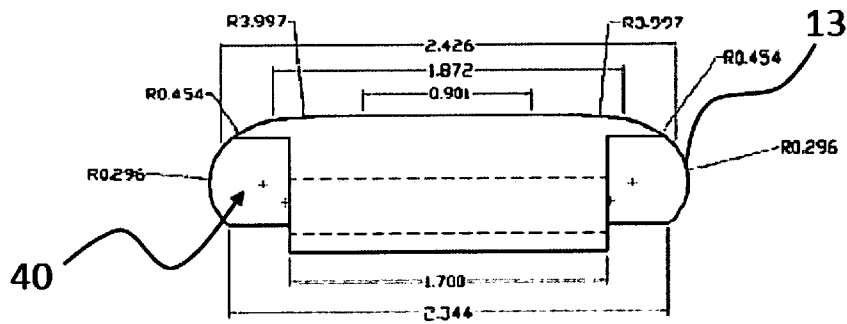

Fig. 4c

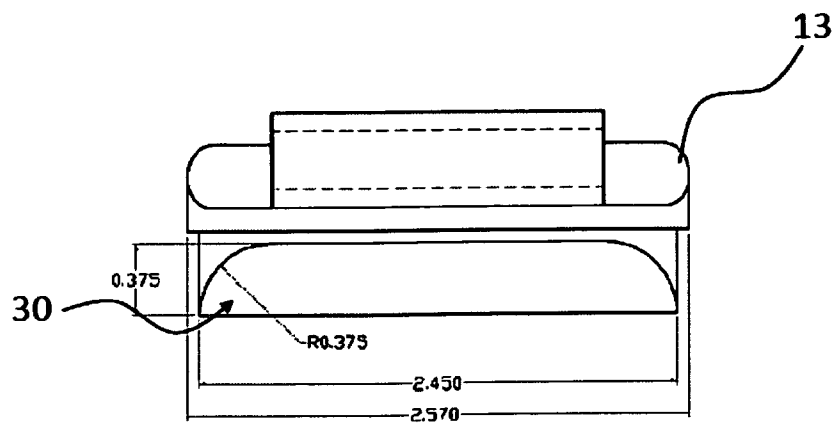

Fig. 5a

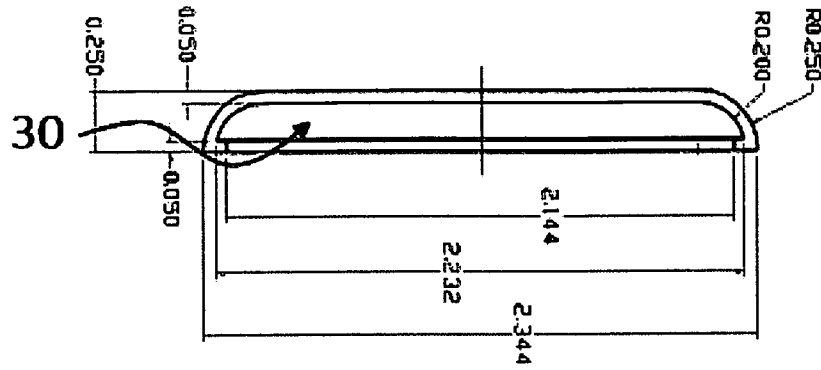

Fig. 5b

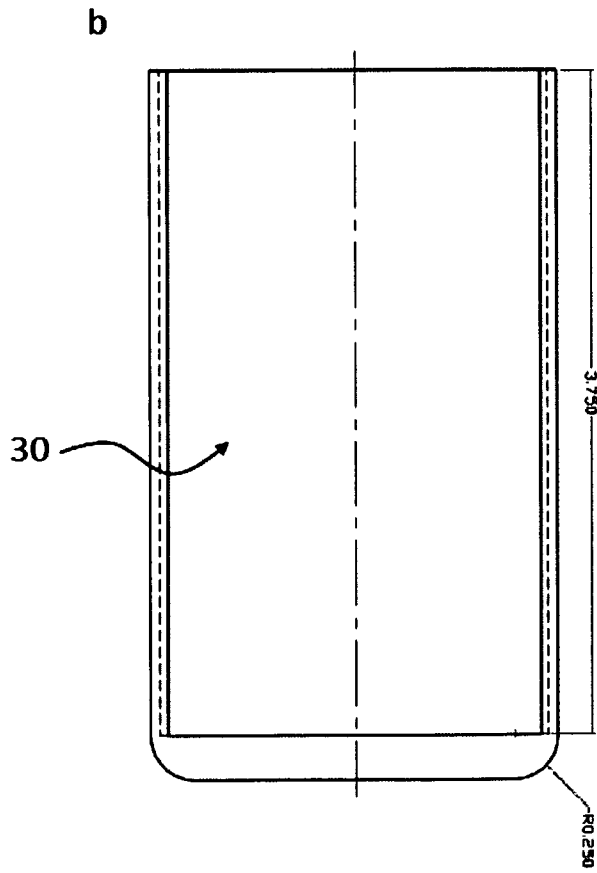

Fig. 5c

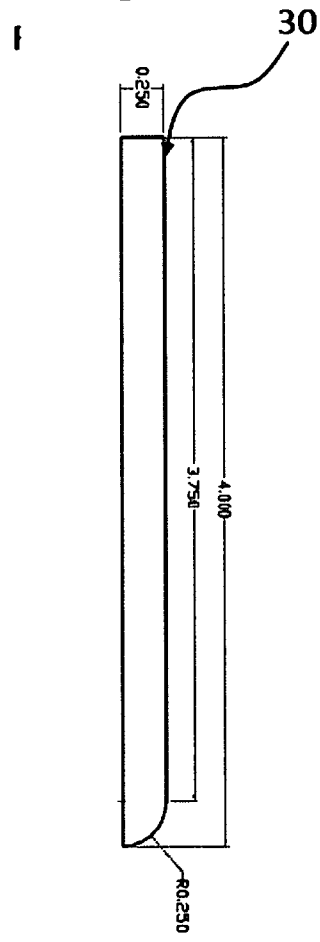

Fig. 7

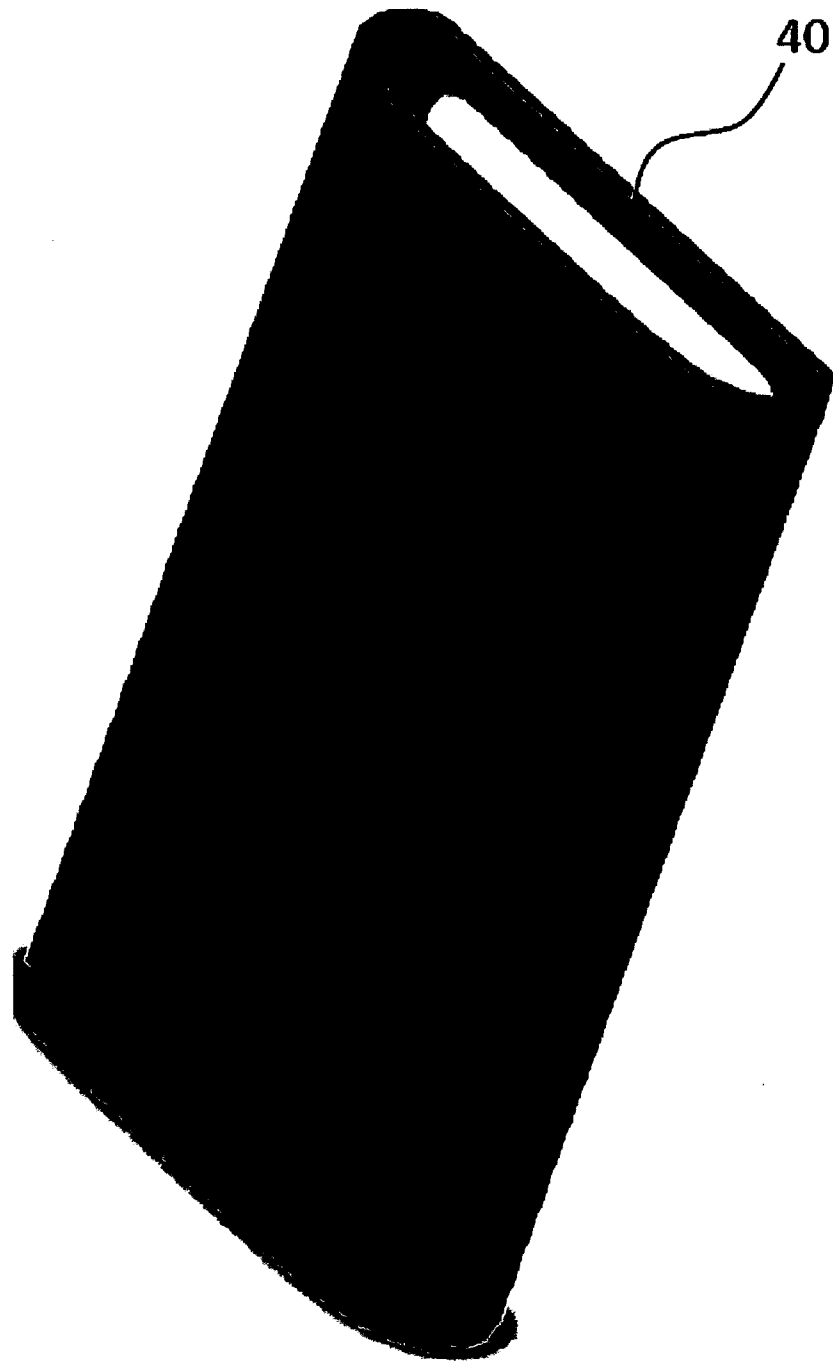

Fig. 8a

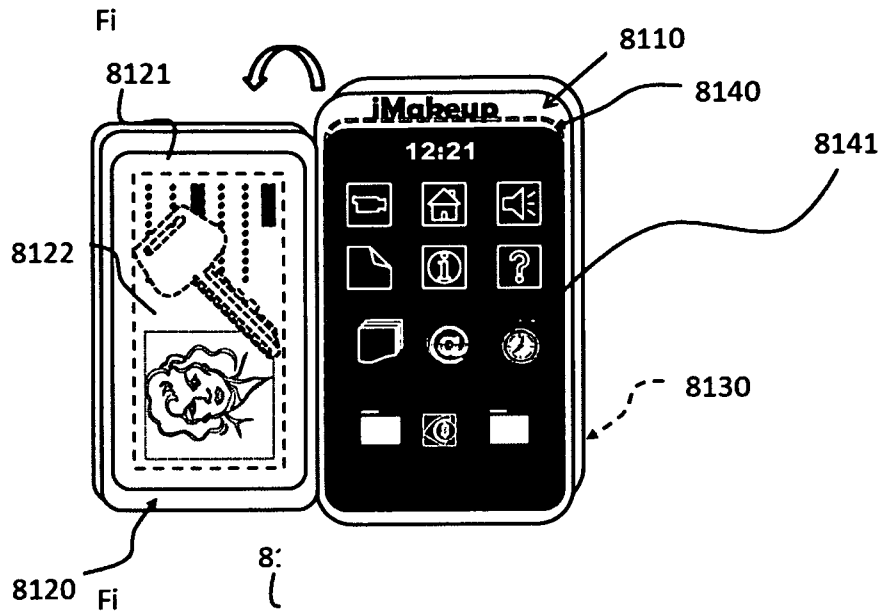

Fig. 8b

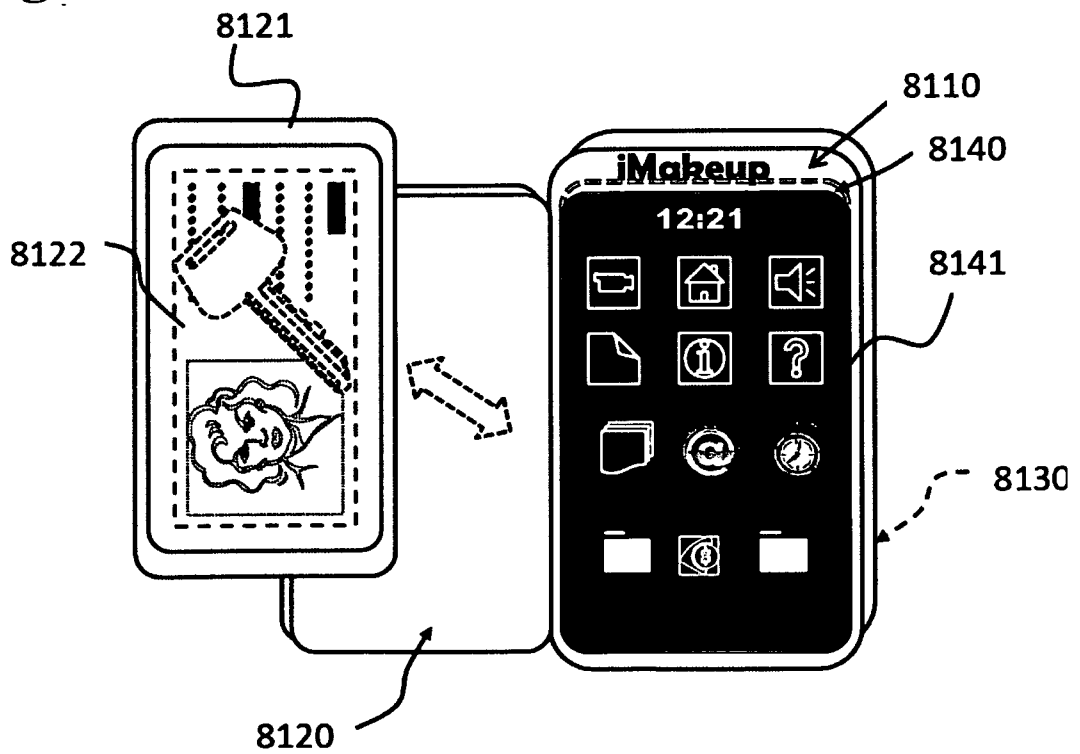

Fig. 9a

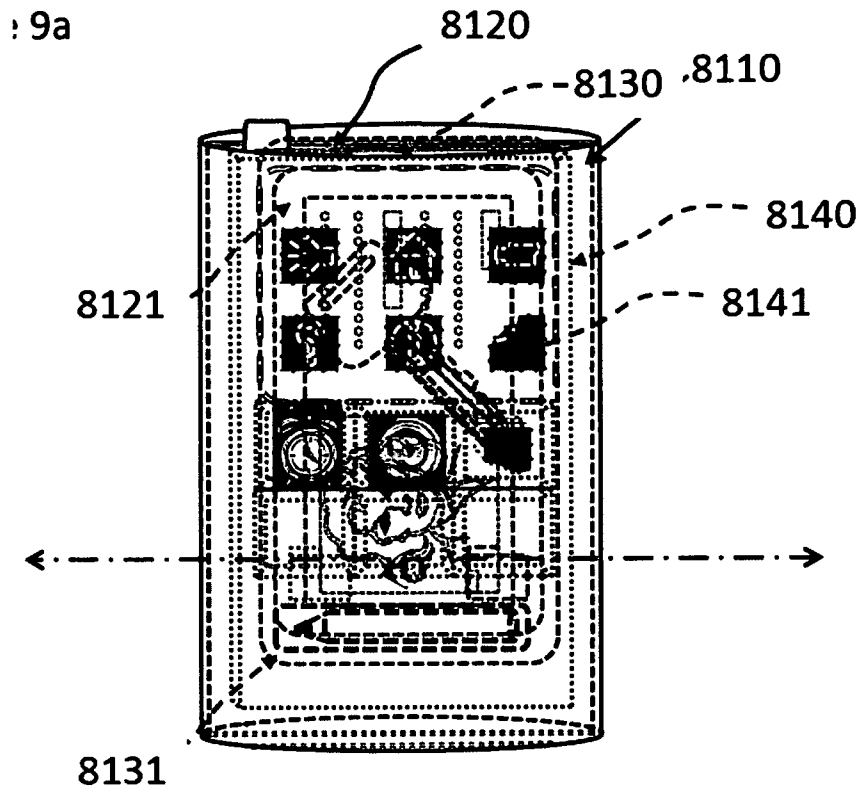

Fig. 9b

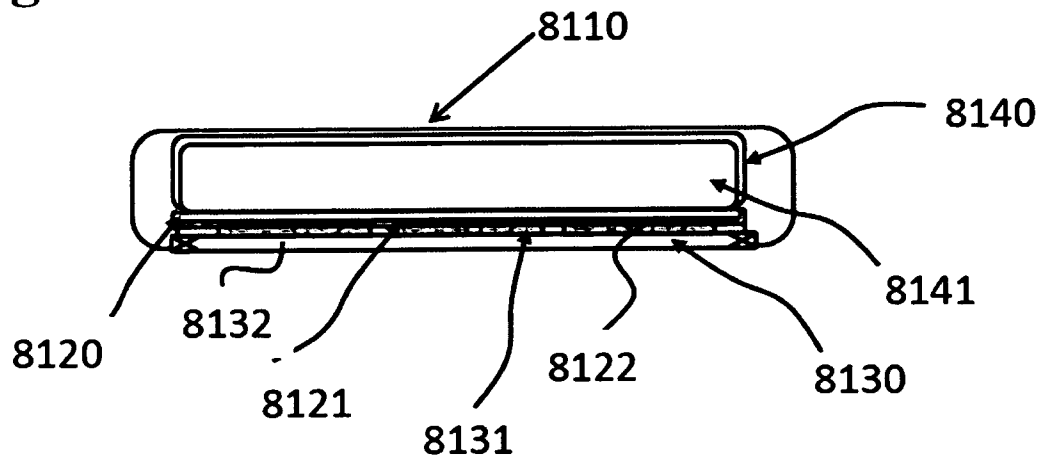

Fig. 10a

1000

1010

1020

1030

1040

1041

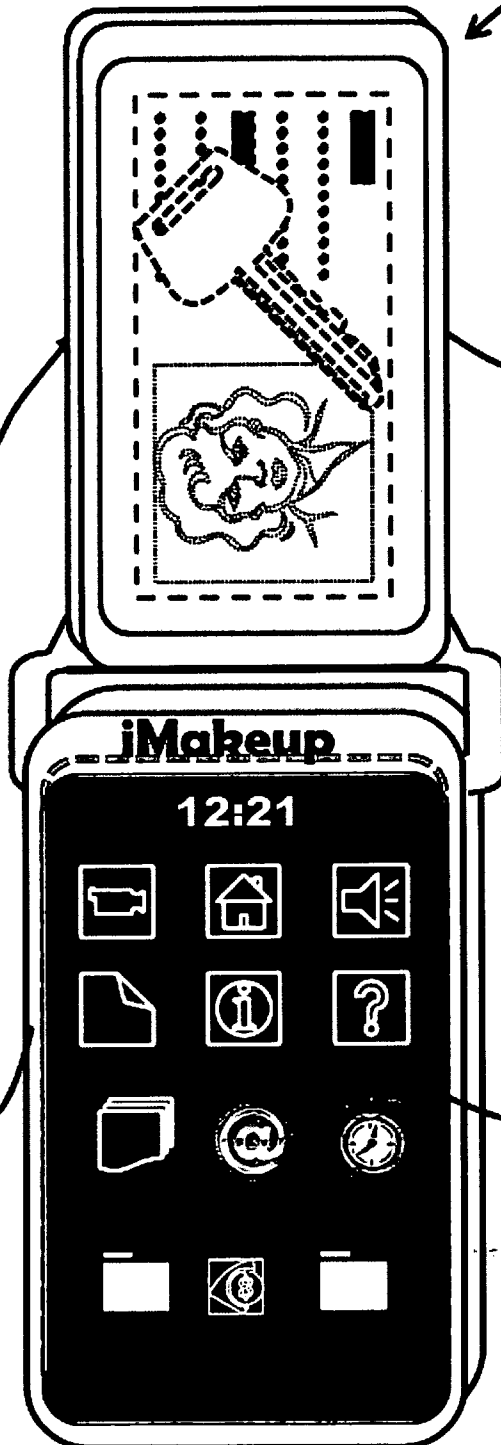

Fig. 11a

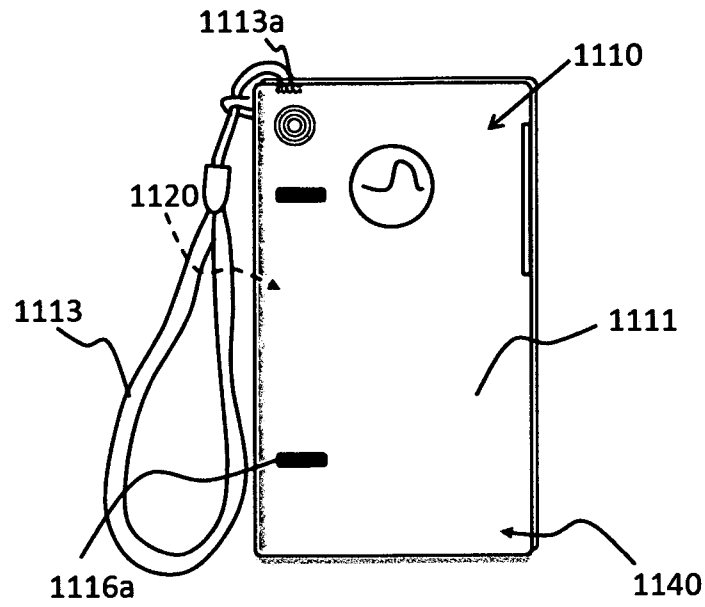

Fig. 11b

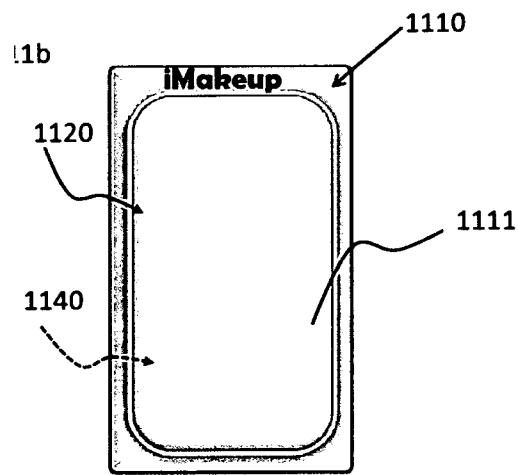

Fig. 12a

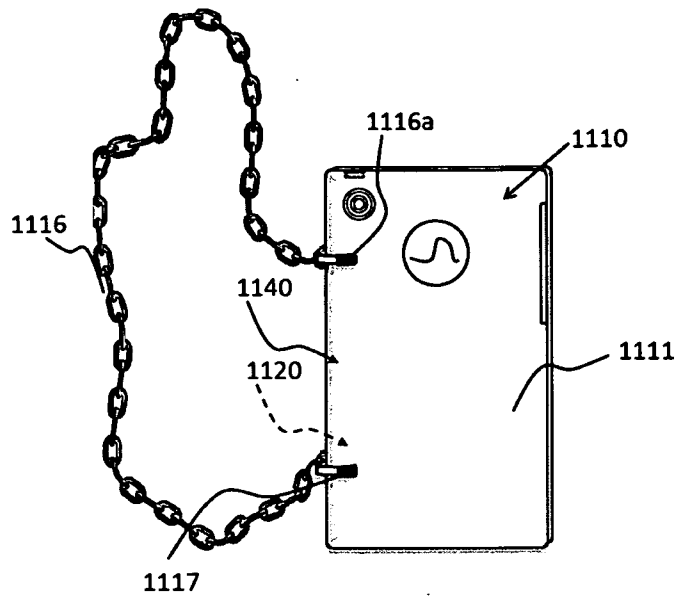

Fig. 12b
111/
Fig. 12b

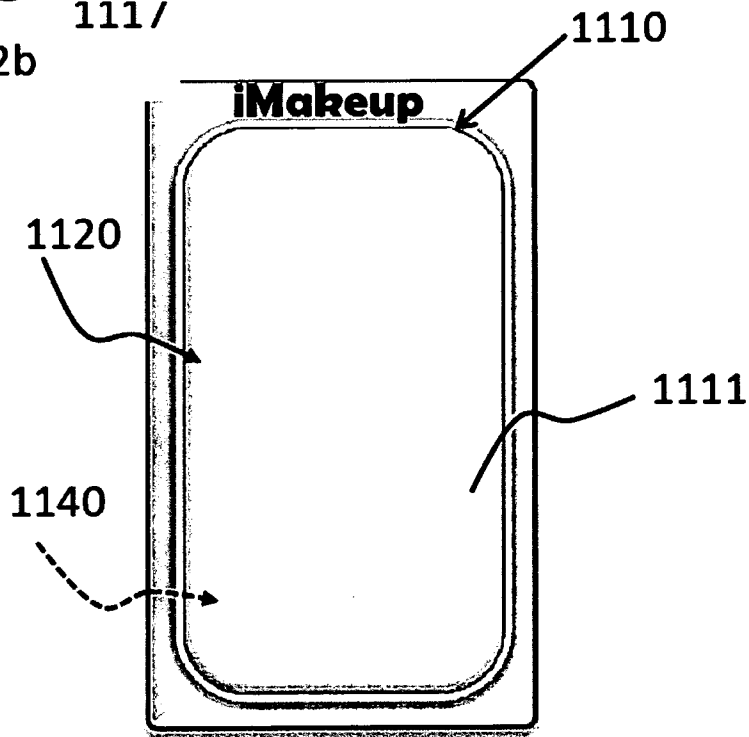

Fig. 13

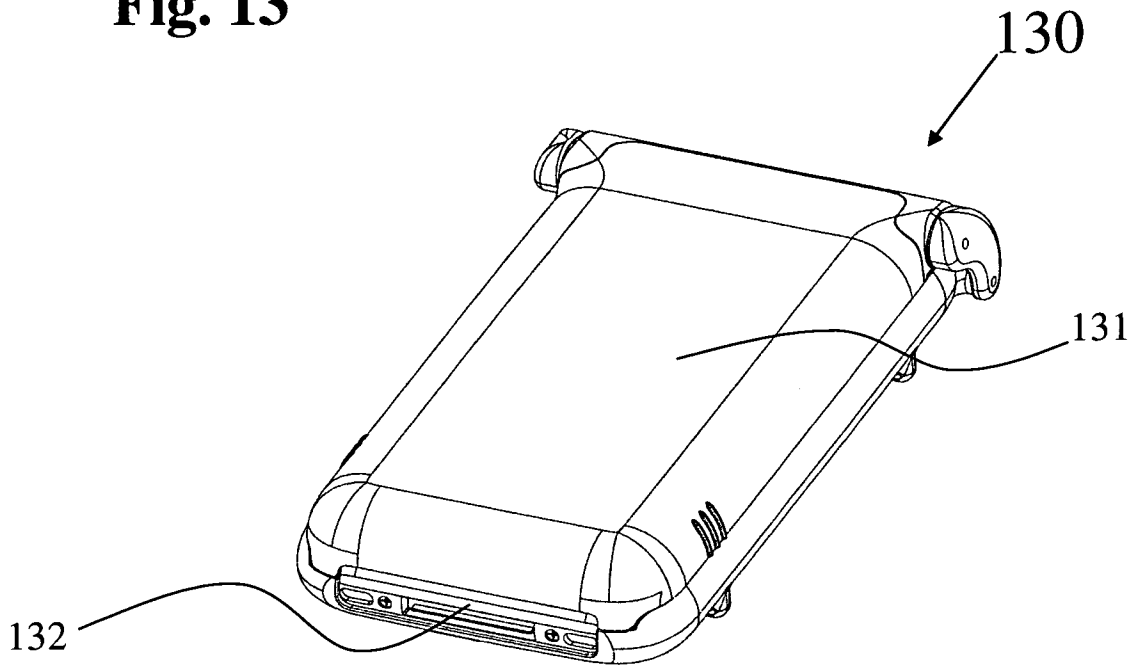

Fig. 14

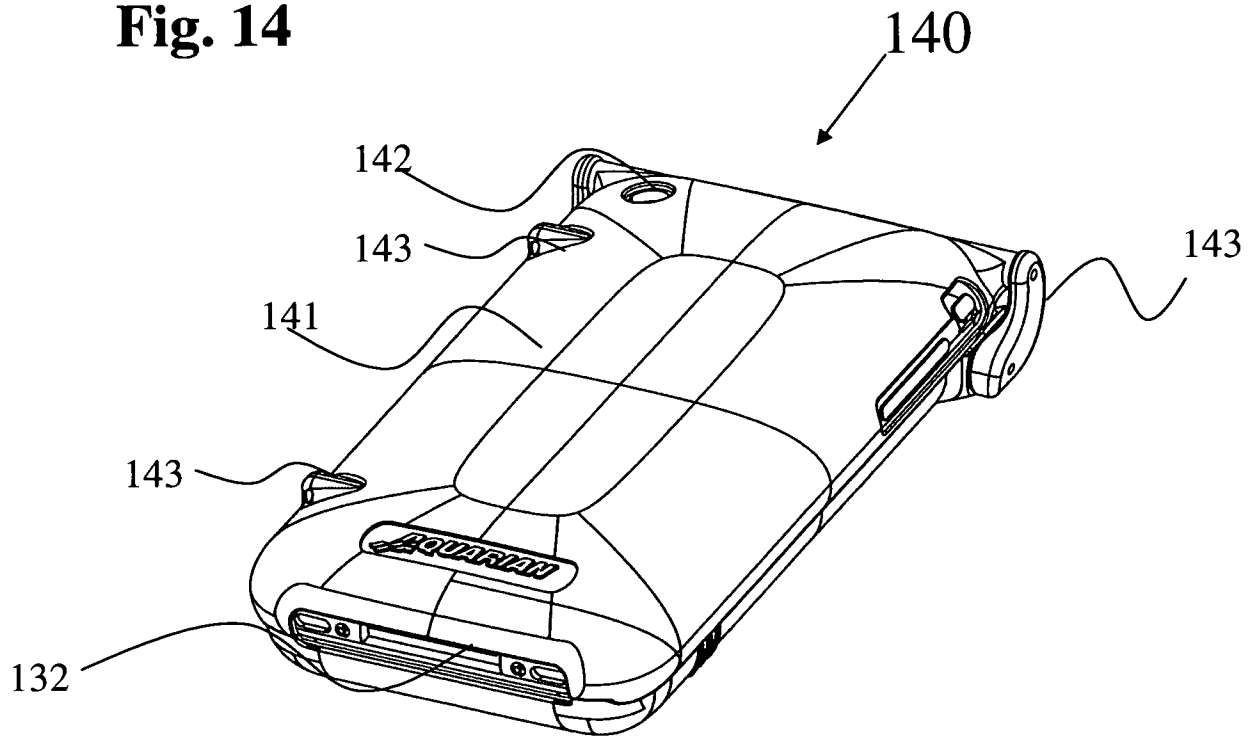

Fig. 15

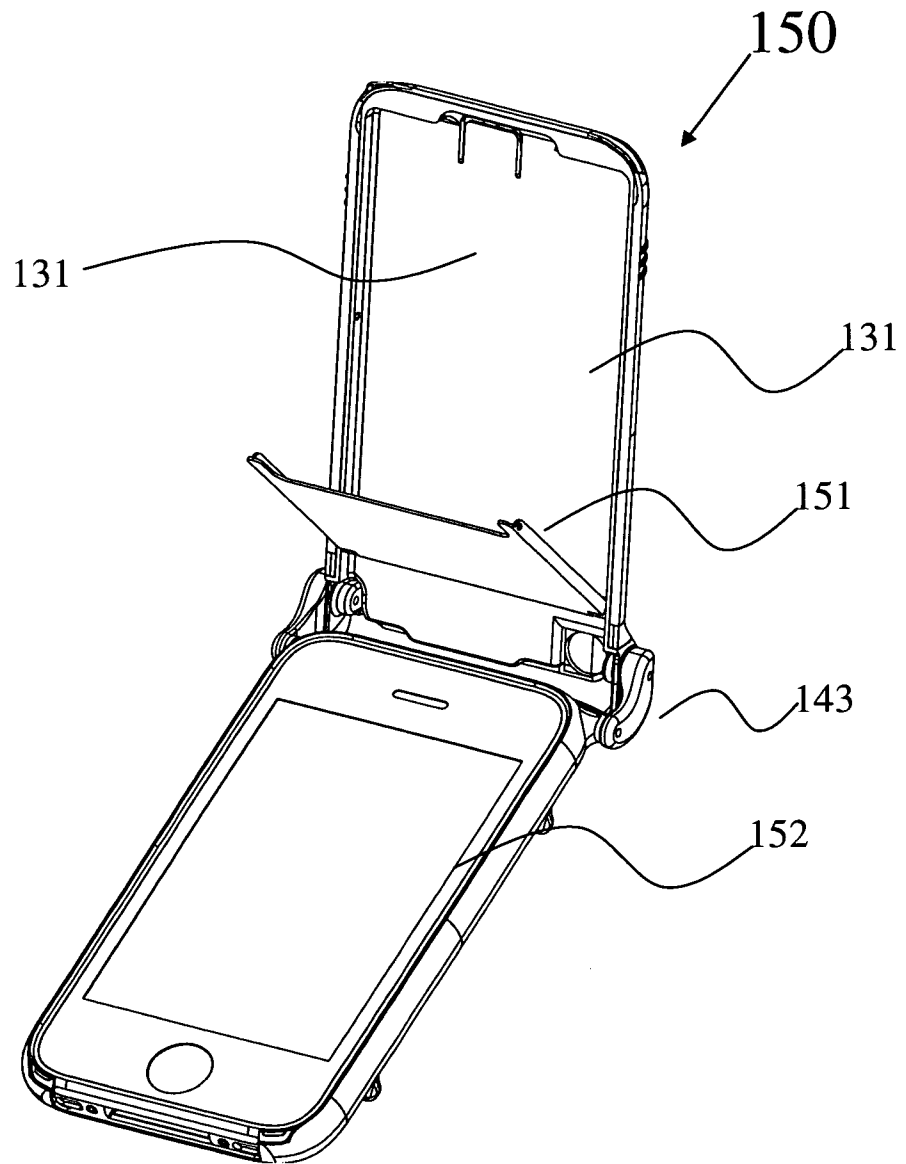

Fig. 16

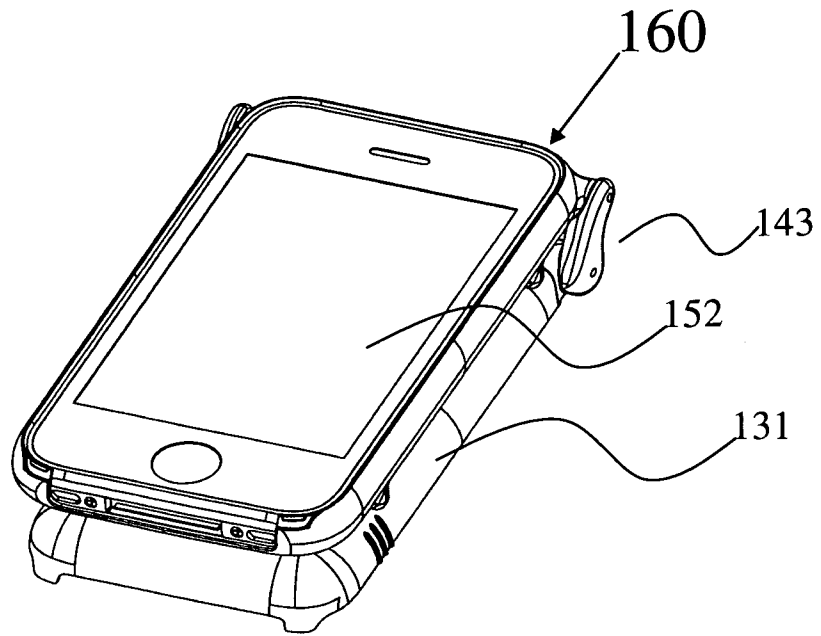

Fig. 17

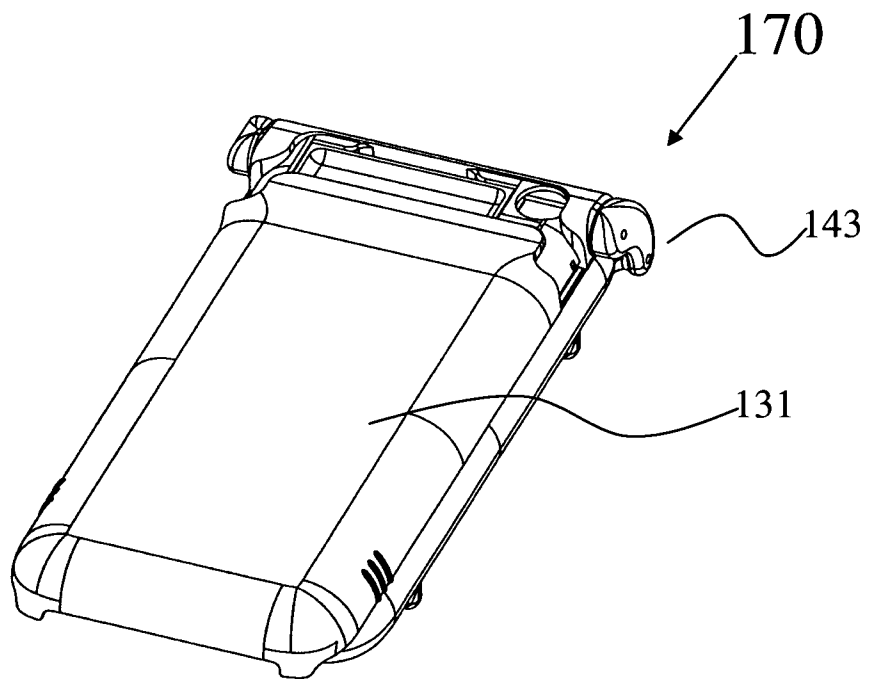
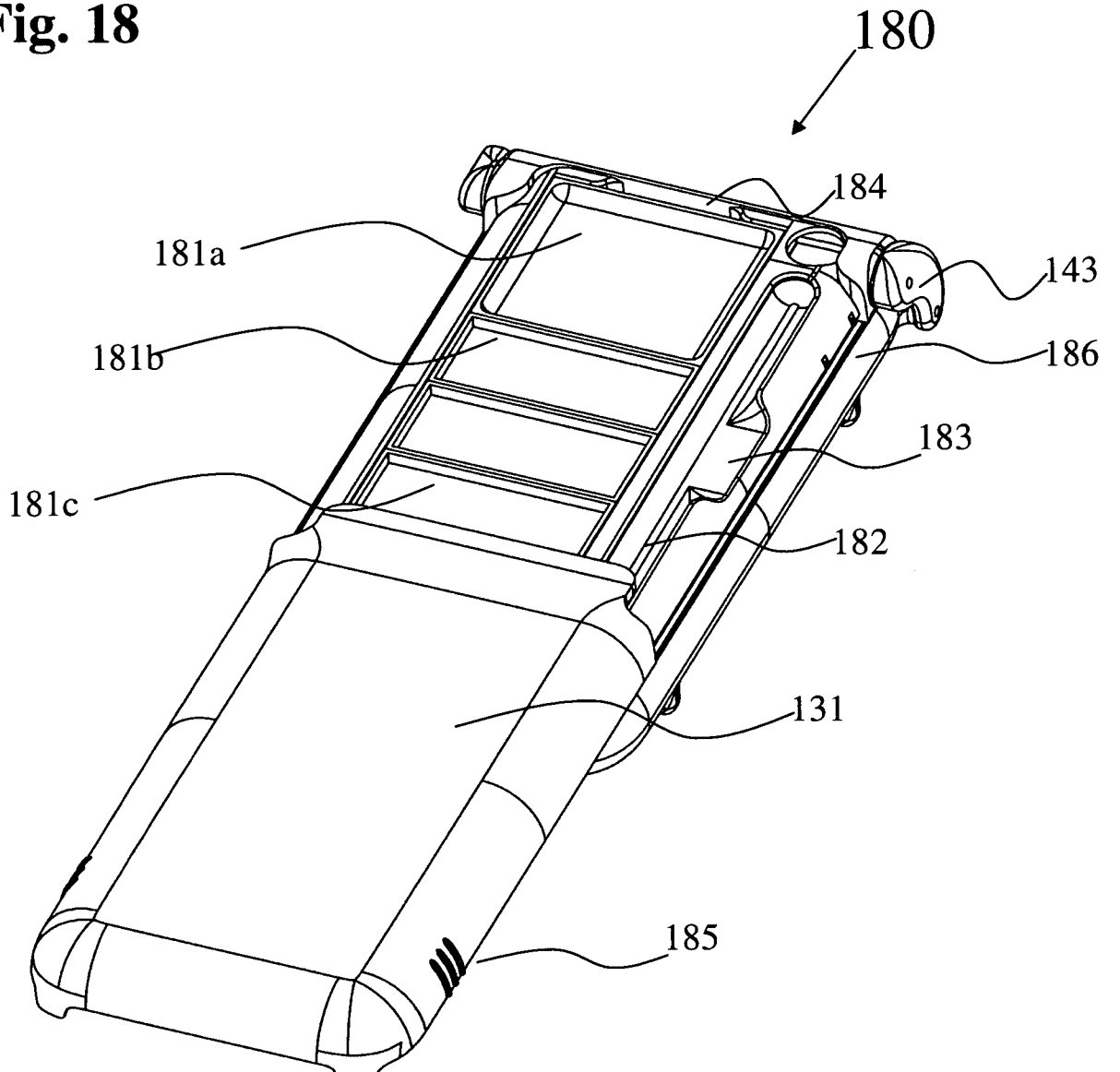

Fig. 18



INTERNATIONAL SEARCH REPORT

International application No.

PCT/US 10/01083

A. CLASSIFICATION OF SUBJECT MATTER

IPC(8) - B65D 85/00 (2010.01)

USPC - 206/320

According to International Patent Classification (IPC) or to both national classification and IPC

B. FIELDS SEARCHED

Minimum documentation searched (classification system followed by classification symbols)
USPC: 206/320

Documentation searched other than minimum documentation to the extent that such documents are included in the fields searched
USPC: 206/38, 235, 320, 521; 224/191, 196; 190/109, 110 (keyword limited; terms below)

Electronic data base consulted during the international search (name of data base and, where practicable, search terms used)

PUBWEST(PGPB, USPT, EPAB, JPAB); Google

Search Terms Used: cosmetic, hygiene, second\$, additional, storage, pocket, compartment, housing, case, cover, protective, media, device, phone, eletronic, cells, lotion, cream, cand\$, gum, mint, breath strip, eye drop, band\$, hand sanitizer, vitamin, pill, wrist, strap, pro

C. DOCUMENTS CONSIDERED TO BE RELEVANT

Category*	Citation of document, with indication, where appropriate, of the relevant passages	Relevant to claim No.
X ----- Y	US 2009/0166247 A1 (GINDI) 02 July 2009 (02.07.2009) fig 1, 2, 3, 4, para [0025]-[0027], [0029]-[0031]	1, 3, 7, 13, 15, 19-23, 26-27 ----- 2, 4-6, 8-12, 14, 16-18, 24, 25, 28-31
Y	US 2006/0112966 A1 (PHUE) 01 June 2006 (01.06.2006) para [0065]-[0067], [0074]-[0076]	2, 4, 6, 16-18, 30-31
Y	US 4,898,195 A (SUSSMAN) 06 February 1990 (06.02.1990) col 3, ln 47-51; Fig 1-3	5
Y	US 7,086,437 B1 (MICHAEL) 08 August 2006 (08.08.2006) col 4, 29-41	8-12
Y	US 2008/0257376 A1 (PIRES ET AL.) 23 October 2008 (23.10.2008), Fig 5	14
Y	US 6,651,854 B1 (LACOSTE) 25 November 2003 (25.11.2003) fig 1, 3, col 2, ln 50-64	29
Y	US 2008/0314941 A1 (KNYCH et al) 25 December 2008 (25.12.2008) para [0032]	24
Y	US 2007/0051645 A1 (HASSETT) 08 March 2007 (08.03.2007) para [0008]	28
Y	US 7,194,289 B1 (FLORES, Jr.) 20 March 2007 (20.03.2007), Fig 1B; col 2, ln 56-64	25

Further documents are listed in the continuation of Box C.

* Special categories of cited documents:	"T" later document published after the international filing date or priority date and not in conflict with the application but cited to understand the principle or theory underlying the invention
"A" document defining the general state of the art which is not considered to be of particular relevance	"X" document of particular relevance; the claimed invention cannot be considered novel or cannot be considered to involve an inventive step when the document is taken alone
"E" earlier application or patent but published on or after the international filing date	"Y" document of particular relevance; the claimed invention cannot be considered to involve an inventive step when the document is combined with one or more other such documents, such combination being obvious to a person skilled in the art
"L" document which may throw doubts on priority claim(s) or which is cited to establish the publication date of another citation or other special reason (as specified)	"&" document member of the same patent family
"O" document referring to an oral disclosure, use, exhibition or other means	
"P" document published prior to the international filing date but later than the priority date claimed	

Date of the actual completion of the international search

19 May 2010 (19.05.2010)

Date of mailing of the international search report

01 JUN 2010

Name and mailing address of the ISA/US

Mail Stop PCT, Attn: ISA/US, Commissioner for Patents
P.O. Box 1450, Alexandria, Virginia 22313-1450

Facsimile No. 571-273-3201

Authorized officer:

Lee W. Young

PCT Helpdesk: 571-272-4300
PCT OSP: 571-272-7774