

E. J. MULLER.
UNIVERSAL ADJUSTABLE BEARING.

No. 524,725.

Patented Aug. 21, 1894.

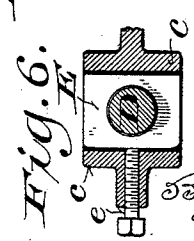
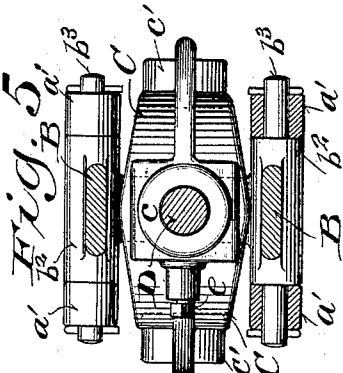
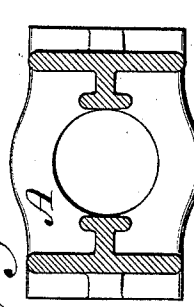
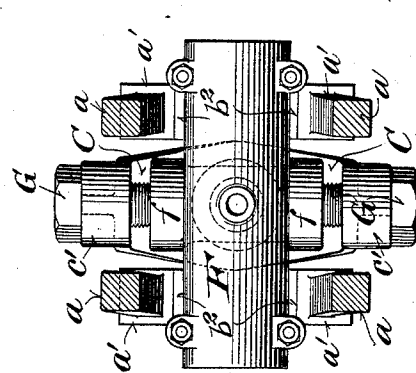
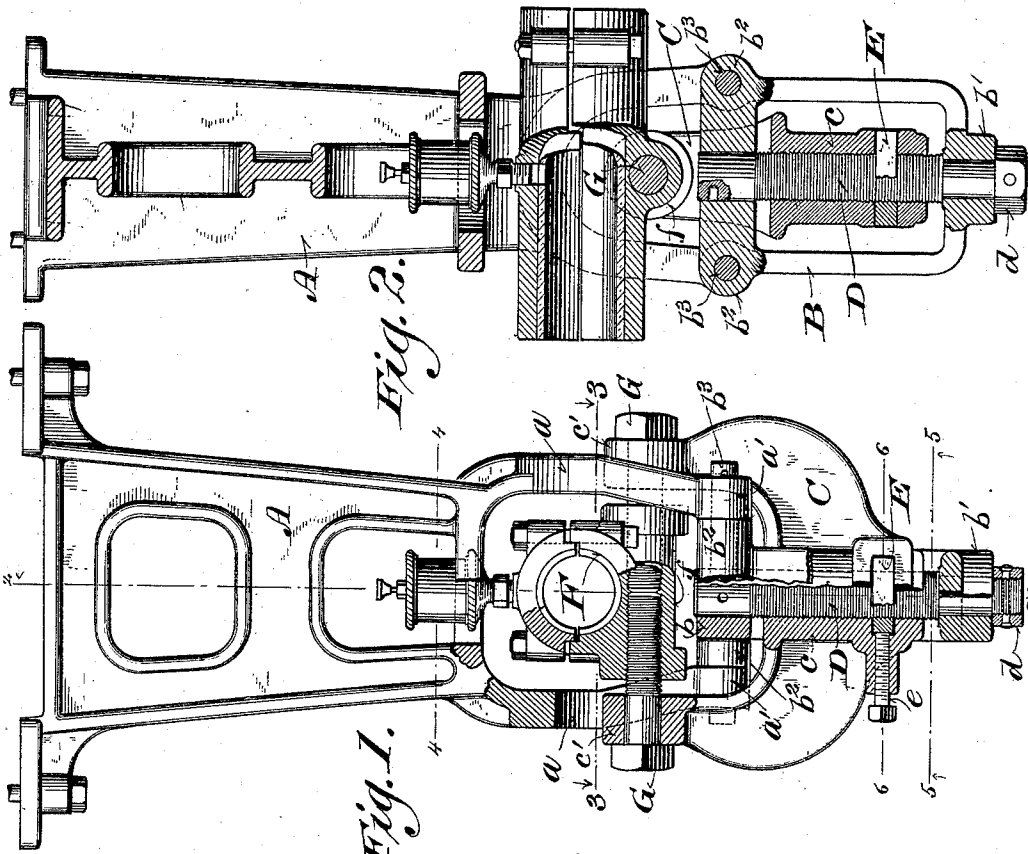

Witnesses:
Geo. W. Young,
Chas. L. Coas.

Inventor:
Ernest J. Muller

By *[Signature]*
Attorneys.

E. J. MULLER.
UNIVERSAL ADJUSTABLE BEARING.

No. 524,725.

Patented Aug. 21, 1894.

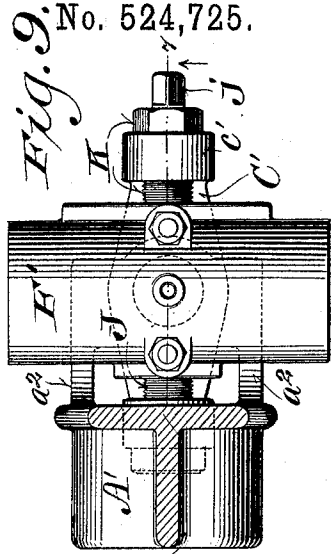

Fig. 9.

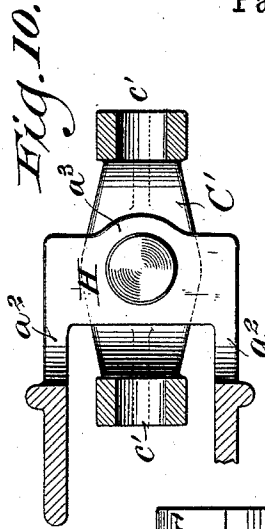

Fig. 10.

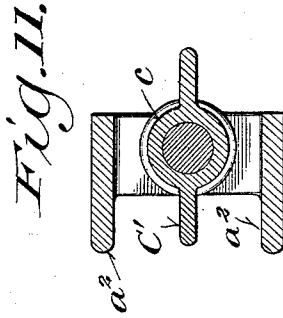

Fig. 11.

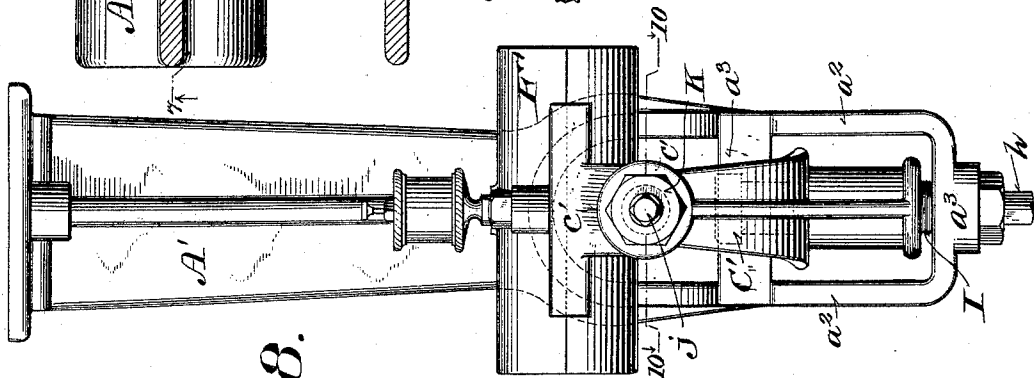

Fig. 8.

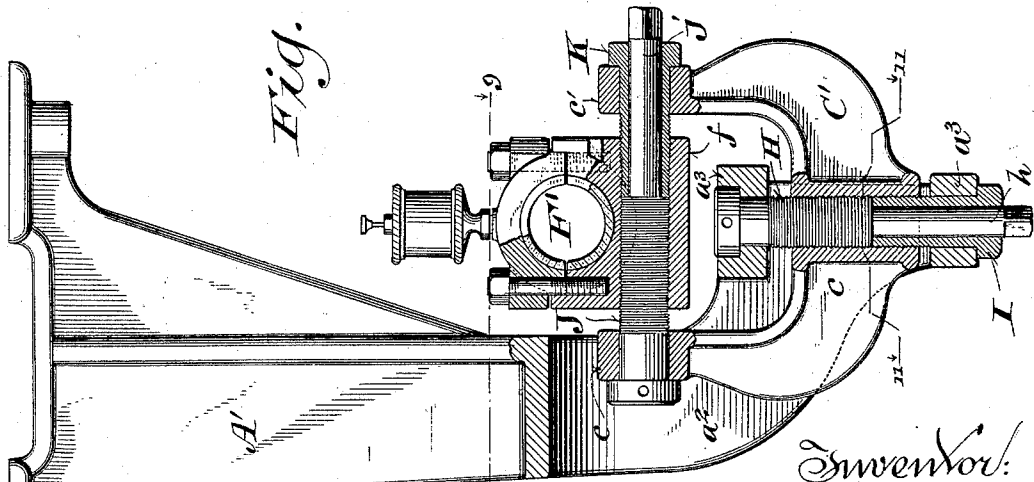

Fig. 7.

Witnesses:
Geo W Young
Char. L. Goss

Inventor:
Ernest J. Muller.

By *Wm. L. ...*
Attorneys.

E. J. MULLER.
UNIVERSAL ADJUSTABLE BEARING.

No. 524,725.

Patented Aug. 21, 1894.

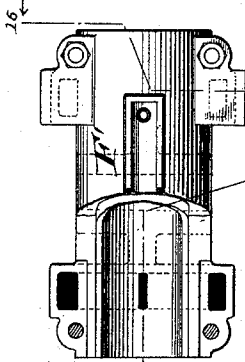

Fig. 15.

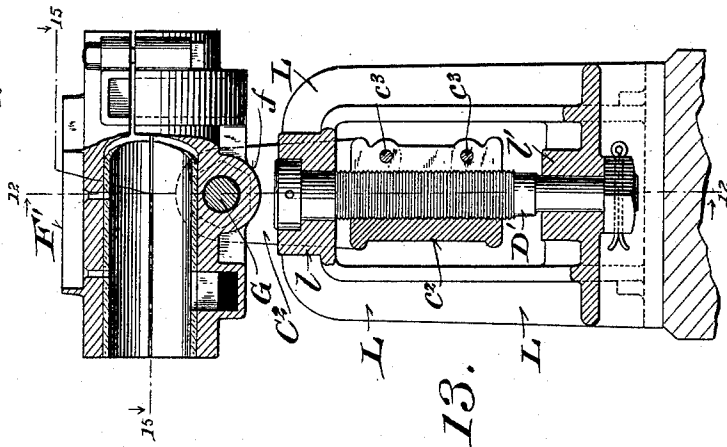

Fig. 16.

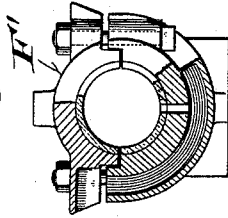

Fig. 17.

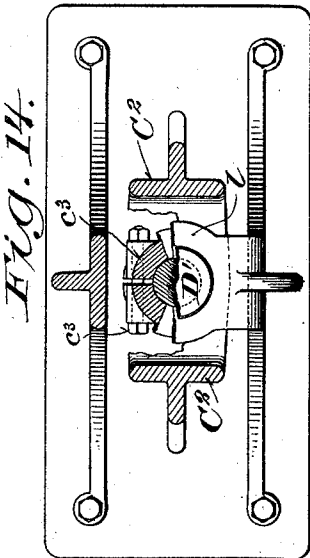

Fig. 14.

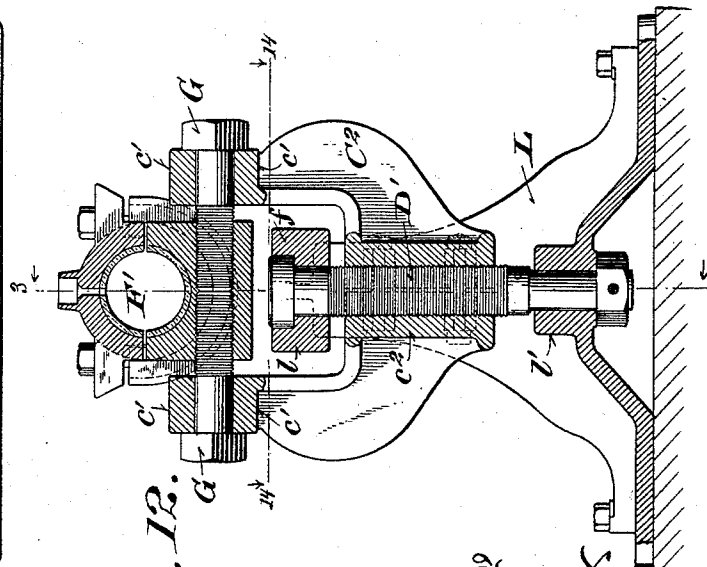

Fig. 13.

Witnesses:
Geo. W. Young.
Chas. L. Coe.

Inventor:
E. J. Muller,
By *Wm. H. ...*
Attorneys.

E. J. MULLER.
UNIVERSAL ADJUSTABLE BEARING.

No. 524,725.

Patented Aug. 21, 1894.

Fig. 21.

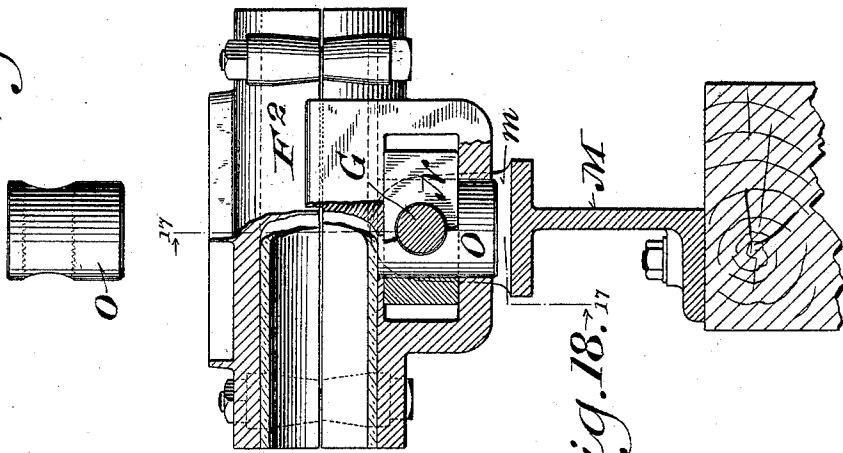

Fig. 18.

Fig. 19.

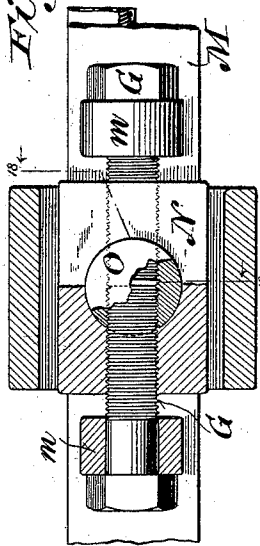

Fig. 17.

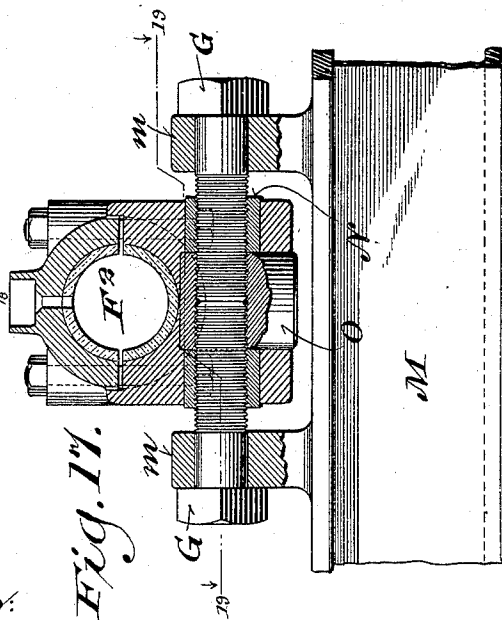
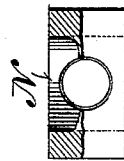

Fig. 20.



Witnesses:
Geo. W. Young,
Chas. L. Goss.

Inventor:
Ernest J. Muller,

By *Wm. H. Underhill*
Attorneys.

UNITED STATES PATENT OFFICE.

ERNST J. MULLER, OF BUTTE, MONTANA.

UNIVERSAL ADJUSTABLE BEARING.

SPECIFICATION forming part of Letters Patent No. 524,725, dated August 21, 1894.

Application filed September 19, 1893. Serial No. 485,757. (No model.)

To all whom it may concern:

Be it known that I, ERNST J. MULLER, of Butte, in the county of Silver Bow and State of Montana, have invented certain new and useful Improvements in Universal Adjustable Bearings; and I do hereby declare that the following is a full, clear, and exact description of the invention, which will enable others skilled in the art to which it pertains to make and use the same, reference being had to the accompanying drawings, and to the letters of reference marked thereon, which form a part of this specification.

The main objects of my invention are to produce and maintain alignment of the boxes with each other and the shaft they support, to enable the boxes to adjust themselves freely and readily to any slight springing or deflection of the shaft from a straight line without binding thereon, and to facilitate the adjustment of the shaft transversely to its axis.

It consists essentially of certain novel features in the construction and arrangement of the box supporting and adjusting connections hereinafter particularly described and pointed out in the claims.

In the accompanying drawings like letters designate the same parts in the several figures.

Figures 1 to 6 inclusive, show one form of my improved adjustable bearing for hangers designed to be attached to a ceiling or overhead support, Fig. 1 being a partial side elevation and vertical medial section, Fig. 2, a vertical section on the line 2, 2, Fig. 1, and Figs. 3, 4, 5 and 6, horizontal sections on the lines 3, 3, 4, 4, 5, 5, and 6, 6, respectively, Fig. 1. Figs. 7 to 11, inclusive, show another form of the bearing for hangers, Fig. 7 being a partial side elevation and vertical section on the line 7, 7, Fig. 9, Fig. 8, a front elevation, and Figs. 9, 10 and 11, cross sections on the lines 9, 9, 10, 10, and 11, 11, respectively, Figs. 7 and 8. Figs. 12 to 16 inclusive, show a modification of the bearing for standards adapted to be attached to and supported by a floor or other horizontal foundation below the bearing, Fig. 12 being a vertical section on the line 12, 12, Fig. 13, Fig. 13, a view partly in vertical section on the lines 13, 13, Figs. 12 and 15, and partly in elevation, Fig. 14, a horizontal section on the line 14, 14, Fig. 12, Fig. 15, a view partly in horizontal section and partly in plan,

on the line 15, 15, Fig. 13, and Fig. 16, a view of the box partly in end elevation and partly in cross section, on the line 16, 16, Fig. 15; and Figs. 17 to 21 inclusive, show a modification of the bearing for circular saw arbors, or other similar uses, Fig. 17 being a vertical section on the line 17, 17, Fig. 18, Fig. 18 a view partly in vertical section and partly in elevation on the line 18, 18, Fig. 19, Fig. 19 a horizontal section on the line 19, 19, Fig. 17, and Figs. 20 and 21, details.

Referring to Figs. 1 to 6 inclusive, A represents a bracket or hanger adapted to be permanently attached to a ceiling or overhead support. It is forked at its lower end into four prongs or arms *aa*, each terminating in a horizontally bored hub *a' a'*. B is a cross head, formed with two central vertically bored hubs or bearings *b b'*, in line with each other, and with two parallel horizontal sleeves *b² b²*, on opposite sides of the hub *b*. These sleeves are fitted endwise between the hubs *a' a'*, to which they are detachably secured by pins *b³ b³*. C is a yoke formed with a central vertically bored and internally threaded sleeve *c*, and above and on opposite sides thereof with two horizontally bored hubs or bearings *c' c'*. The sleeve *c* is made somewhat shorter than the distance between the hubs *b* and *b'*, to which it is pivotally and adjustably secured by the vertical screw D. This screw is formed at the ends with plain cylindrical portions fitted to the bores of hubs *b* and *b'*, the lower end being reduced in diameter and provided with a nut *d*, and the upper end being formed with holes to receive a spanner wrench. The intermediate threaded portion of the screw engages with the internally threaded sleeve *c* of the yoke C, which is mounted thereon. The shoulder and the nut *d* at the lower reduced end of the screw bear against opposite ends of the hub *b'* and restrain said screw from endwise movement in the cross head B while it is permitted to turn freely therein. E is a square or oblong nut, loosely fitted in a transverse recess in sleeve *c*, and threaded upon the screw D. A set screw *e*, threaded in one side of said sleeve, is arranged to bear at the tip against one edge of said nut, and serves to bind the same upon the screw D, and thus prevent the sleeve *c* from turning thereon after it has been properly set or ad-

justed. F is the journal box, the lower half of which is formed or provided with a transverse internally threaded sleeve *f*, the length of which is somewhat shorter than the distance between the hubs *c' c'*, to which it is pivotally and adjustably secured by the screws G G. These screws are formed with heads and between the heads and threaded portions with plain portions fitted to the bores of said hubs *c' c'*, in which they are free to turn. They are screwed from opposite directions into the sleeve *f*, and when forced together at the tips, are caused to bind against the thread in said sleeve and are thus prevented from turning therein. They are made of such a length that when their tips are forced together there will be slight play between their heads and the outer ends of the hubs *c' c'*, thereby preventing their binding therein. The screws D and G G, turning freely in their supporting bearings *b b'* and *c' c'* in lines perpendicular to each other, constitute in connection with yoke C a universal joint and permit the box F to turn freely in any direction from its center and thereby to adapt itself to any slight deflection or irregularity in the shaft which it supports, thus preventing its binding upon said shaft. The bearings of said pivot screws, being considerably separated, afford firm supports therefor, and rigidly hold the center of the box in its proper position, at the same time permitting the free universal movement thereof about its center, as above explained. The box is adjusted vertically by loosening the set screw *e*, and turning the vertical pivot screw D by means of a wrench applied to the nut *d*, which is pinned or otherwise rigidly secured thereto. It is adjusted horizontally in either direction by loosening either of the screws G, and turning up the other, so as to draw the box in the required direction. When properly adjusted the yoke C is locked upon the vertical screw D by setting up the set screw *e* against the nut E, and the screws G G are locked and prevented from turning in the sleeve *f* by turning their tips firmly against each other. By this means the accurate fitting and attachment of the bracket or hanger to its support is rendered unnecessary, because the final adjustment of the box and its accurate alignment with other boxes may be readily effected in the manner just described. In the same way, any settling or deflection of the structure to which the hanger is attached may be compensated for. The construction described also affords means for readily taking down shafting without disturbing the hangers. This is effected by simply removing the pins *b³ b³*. The construction of the hanger and the box supporting connections affords a strong, firm support for the box on both sides of the shaft.

Referring to Figs. 7 to 11 inclusive, A' is a depending bracket or hanger, which like that above described, is designed to be permanently attached to a ceiling or other overhead

support. It is forked at its lower end and formed between its two arms or prongs *a² a²*, which are turned to one side, with two vertically bored hubs *a³ a³*, in line with each other. C' is a yoke like or similar to that hereinbefore described, formed with a central vertical internally threaded sleeve *c*, the length of which is somewhat shorter than the distance between the hubs *a³ a³* with which it is pivotally connected by adjusting screws H and I, formed with heads, and between the heads and threaded portions thereof, with plain cylindrical portions, which are fitted to and turn freely in the bores of said hubs. The screw H has a cylindrical head, which is provided with holes to receive a spanner wrench, and the upper hub *a³* is counter-sunk to receive it. It is formed with a reduced cylindrical extension *h*, which is squared at the end to receive a wrench. The other screw I, has a squared head and is bored axially to permit of the passage through it of the reduced extension *h* of the other screw, the squared end of which protrudes below the head of the screw I. These screws are turned from opposite directions into the threaded sleeve *c* of said yoke, and are made of such length that when the end of the screw I abuts against the shoulder on screw H, there will be sufficient play between the heads of said screws and the hubs *a³ a³*, to permit of their turning freely therein. Turning the abutting portions of said screws tightly together causes the threads thereon to bind in the thread of the sleeve *c* and thereby holds it rigidly thereon. The yoke C' is formed on opposite sides of said sleeve with upwardly projecting arms which terminate in horizontally bored hubs *c' c'*, in line with each other, as in the device first described. F' is the journal box, the lower half of which is formed or provided with a transverse internally threaded sleeve *f*, somewhat shorter in length than the distance between the hubs *c' c'*. It is pivotally connected with the yoke C' by screws J and K, like or similar to the screws H and I, in a line at right angles thereto, the threaded portions of said screws engaging, when the parts are assembled, with the thread in said sleeve *f*, and the plain cylindrical portions thereof being fitted and turning freely in the hubs *c' c'*. The screw J is inserted through the rear hub and the screw K through the front hub, so as to bring both the head of the screw K and the squared end of the reduced cylindrical extension *j* of the screw J into an easily accessible position at the front of the hanger. It is obvious that for either or both the vertical or horizontal pivot and adjusting screws H I and J K, screws like those shown and described in connection with Fig. 1 might be employed, but the screws J and K afford more convenient means of adjusting the box horizontally in this form of hanger, inasmuch as they are both turned from the front side of the hanger, whereas with screws like G G, it would be necessary

to insert a wrench between the arms or prongs $a^2 a^2$ of the hanger to turn the rear screw. This would be found inconvenient, if not difficult. By removing the horizontal pivot screws, the shaft, together with its boxes, can be readily taken down without disturbing their supporting hangers or brackets A' . It will be observed that in both forms of the device hereinbefore described, the heads or squared ends of both the vertical and horizontal adjusting screws are exposed in convenient position for the application of a wrench, and the permanent adjustment of the boxes is thus greatly facilitated.

Referring to Figs. 12 to 16 inclusive, illustrating a form of the device specially adapted for use in connection with dynamos, where the shafts are supported in stands a sufficient distance above the floor or foundation to raise the pulleys and wheels on such shafts clear of the floor or foundation, L represents a stand or bracket designed to be permanently attached to the floor timbers or a horizontal foundation below the bearing, and formed with two separated vertically bored hubs ll' in line with each other. C^2 is a yoke like or similar to the yokes C and C' , shown in Figs. 1 and 7, formed with a vertical internally threaded sleeve c^2 , the length of which is somewhat shorter than the distance between the hubs ll' to admit of the vertical adjustment of said yoke, which is supported between them upon a vertical screw D' , similar to the screw D , shown in Fig. 1. This screw has a cylindrical head and a nut at the opposite end by which it is held from endwise movement in said hubs. It is formed next to its head and nut with plain cylindrical portions fitted to turn in said hubs, and is provided just above the hub l' with holes to receive a spanner wrench. The sleeve c^2 is split lengthwise on one side and formed with transversely perforated bosses, connected by screws $c^3 c^3$, by means of which said sleeve is clamped tightly and prevented from turning upon said screw. The yoke C^2 , like those previously described, is formed on opposite sides of the sleeve c^2 with two upwardly projecting arms terminating with horizontally bored hubs $c' c'$ in line with each other. The lower member of the box F' is formed with a transverse internally threaded sleeve f , of a length shorter than the distance between the hubs $c' c'$ with which it is pivotally and adjustably connected by screws $G G$, like those described in connection with Fig. 1.

Referring to Figs. 17 to 21 inclusive, illustrating a form of the device specially adapted for use with circular saw arbors, M represents a portion of the saw frame, formed or provided with two upwardly projecting ears $m m$, bored horizontally in line with each other. F^2 represents the box, the lower member of which is formed transversely to the axis of the box with a rectangular opening in which is fitted a block N , which is somewhat narrower than

the said opening, as shown in Figs. 18 and 19. A short pin O , is fitted in a cylindrical hole formed in the lower member of said box and intersecting said block N vertically. An internally threaded bore is formed lengthwise through said block intersecting the pin O transversely, and in said bore are inserted from opposite directions the pivot and adjusting screws $G G$, which are supported on opposite sides of the box and turn next to their heads in the perforated ears $m m$. The width of the lower member of the box and the length of the block N are somewhat less than the distance between said ears $m m$, so as to permit of the horizontal adjustment of the box transversely to its axis. This adjustment is effected, as hereinbefore explained, by turning out one of the adjusting screws G and turning the other in to meet it. The abutment of said screws against each other at their tips rigidly secures them in place in the block N , and pin O , and prevents their heads from binding against the outer faces of the ears $m m$. In this form of the device the box is permitted to turn about its center in all directions to accommodate itself to any irregularity or deflection of the shaft which it supports, and its permanent horizontal adjustment crosswise of the shaft is provided for as in the other forms hereinbefore described, but in connection with a circular saw arbor the vertical adjustment of the box is unnecessary and therefore dispensed with. The screws $G G$ afford not only the pivot connections on which the box turns vertically, but also convenient means for readily adjusting the box horizontally and transversely to its axis to change the lead of the saw.

I claim—

1. The combination with the box and its support, of two abutting pivot screws arranged transversely to the axis of the box in line with each other and threaded in one part and free to turn in the other, substantially as and for the purposes set forth.

2. The combination with the box, its support and an intermediate connecting yoke having a pivot connection with said support in a line transverse to the axis of the box, of abutting pivot and adjusting screws connecting said box with said yoke in a line transverse to their axes, substantially as and for the purposes set forth.

3. The combination with the box and pivot supports on opposite sides thereof, of abutting pivot and adjusting screws threaded in line with each other into a part of said box transversely to its axis, and free to turn in said pivot supports, substantially as and for the purposes set forth.

4. The combination with a journal box and its support provided with a pair of separated hubs in line with each other, of a yoke to which said box is pivoted having an internally threaded sleeve, a pivot and adjusting screw threaded in said sleeve and having bear-

ings at opposite ends in said hubs, and a locking device for securing said screw immovably in said sleeve, substantially as and for the purposes set forth.

5 5. The combination with a journal box and its support provided with a pair of separated hubs in line with each other, of a yoke to which said box is pivoted having an internally threaded sleeve, a pivot and adjusting screw threaded in said sleeve and having bearings at opposite ends thereof in said hubs, a lock nut inserted in a recess in said sleeve upon said screw, and a set screw adapted to bear against said nut, substantially as and for the purposes set forth.

10 6. The combination with a journal box and its support, provided with a pair of separated hubs in line with each other, of an intermediate connecting yoke to which said box is pivoted in a line perpendicular to its axis and having an internally screw threaded sleeve perpendicular to said line and the axis of said box, and a pivot and adjusting screw threaded into said sleeve and having bearings at each end thereof in said hubs, substantially as and for the purposes set forth.

15 7. The combination with a journal box and its support, provided with a pair of separated hubs in line with each other, of an intermediate yoke having a pair of separated hubs in line with each other, and an internally screw threaded sleeve perpendicular thereto, pivot and adjusting screws connecting said yoke with said box and with said support threaded in a part of the box and in said sleeve, and having bearings on opposite sides of the box in the hubs of said yoke and at opposite ends of said sleeve in the hubs of said support in lines perpendicular to each other and to the axis of the box, substantially as and for the purposes set forth.

20 8. The combination with a journal box and a hanger, of a cross head detachably connected with said hanger and provided with two separated hubs in line with each other, a yoke having an internally threaded sleeve, and pivotally connected with said box in a line perpendicular to its axis and to said sleeve, and a pivot and adjusting screw threaded in said sleeve and having bearings at opposite ends thereof in the hubs of said cross head, substantially as and for the purposes set forth.

9. The combination with a journal box and a hanger forked at its lower end, of a cross head detachably connected with said hanger and provided with two separated hubs in line with each other, a yoke having two separated hubs in line with each other, and an internally threaded sleeve perpendicular thereto, and pivot and adjusting screws threaded into a part of said box and into said sleeve and having bearings on opposite sides of the box in the hubs of said yoke and at opposite ends of said sleeve in the hubs of said cross head, in lines perpendicular to each other and to the axis of said box, substantially as and for the purposes set forth.

10. The combination with a journal box and a hanger forked at its lower end into four arms each terminating in a transversely bored hub, of a cross head having two transverse sleeves and a pair of separated hubs in line with each other and perpendicular to said sleeves, pins passing through said sleeves and the hubs of the hanger and detachably securing the parts together, and a yoke pivoted to said box and to said cross head in lines perpendicular to each other and to the axis of said box, substantially as and for the purposes set forth.

11. The combination with a journal box and its support with which it has a universal joint connection, of abutting pivot and adjusting screws passing through a part of said box, and hubs or bearings on opposite sides thereof in line with each other and threaded in the one and free to turn in the other, said screws constituting a part of said universal joint connection, substantially as and for the purposes set forth.

12. The combination of a hanger, forked at its lower end, a cross head detachably connected with the arms of said hanger and a journal box independently supported by and having a universal joint connection with said cross head, substantially as and for the purposes set forth.

In testimony that I claim the foregoing as my own I affix my signature in presence of two witnesses.

ERNST J. MULLER.

Witnesses:

JOHN B. MCCLERNAN,
B. C. W. EVANS.