



- (51) International Patent Classification:  
*H04L 5/00* (2006.01) *H04W 72/04* (2009.01)
- (21) International Application Number:  
PCT/EP2011/052679
- (22) International Filing Date:  
23 February 2011 (23.02.2011)
- (25) Filing Language: English
- (26) Publication Language: English
- (71) Applicant (for all designated States except US): **TELEFONAKTIEBOLAGET L M ERICSSON (PUBL)** [SE/SE]; S-16483 Stockholm (SE).
- (72) Inventors; and
- (75) Inventors/Applicants (for US only): **FALCONETTI, Laetitia** [FR/DE]; Oligsbendengasse 11, 52070 Aachen (DE). **KOUTSIMANIS, Chrysostomos** [GR/SE]; Västra Vägen 3B/3tr, S-16961 Solna (SE).
- (74) Agent: **SCHWARZ, Markku**; Thomas-Wimmer-Ring 15, 80539 München (DE).
- (81) Designated States (unless otherwise indicated, for every kind of national protection available): AE, AG, AL, AM,

AO, AT, AU, AZ, BA, BB, BG, BH, BR, BW, BY, BZ, CA, CH, CL, CN, CO, CR, CU, CZ, DE, DK, DM, DO, DZ, EC, EE, EG, ES, FI, GB, GD, GE, GH, GM, GT, HN, HR, HU, ID, IL, IN, IS, JP, KE, KG, KM, KN, KP, KR, KZ, LA, LC, LK, LR, LS, LT, LU, LY, MA, MD, ME, MG, MK, MN, MW, MX, MY, MZ, NA, NG, NI, NO, NZ, OM, PE, PG, PH, PL, PT, RO, RS, RU, SC, SD, SE, SG, SK, SL, SM, ST, SV, SY, TH, TJ, TM, TN, TR, TT, TZ, UA, UG, US, UZ, VC, VN, ZA, ZM, ZW.

- (84) Designated States (unless otherwise indicated, for every kind of regional protection available): ARIPO (BW, GH, GM, KE, LR, LS, MW, MZ, NA, SD, SL, SZ, TZ, UG, ZM, ZW), Eurasian (AM, AZ, BY, KG, KZ, MD, RU, TJ, TM), European (AL, AT, BE, BG, CH, CY, CZ, DE, DK, EE, ES, FI, FR, GB, GR, HR, HU, IE, IS, IT, LT, LU, LV, MC, MK, MT, NL, NO, PL, PT, RO, RS, SE, SI, SK, SM, TR), OAPI (BF, BJ, CF, CG, CI, CM, GA, GN, GQ, GW, ML, MR, NE, SN, TD, TG).

Published:  
— with international search report (Art. 21(3))

(54) Title: COMMUNICATION OF DATA USING INDEPENDENT DOWNLINK AND UPLINK CONNECTIONS

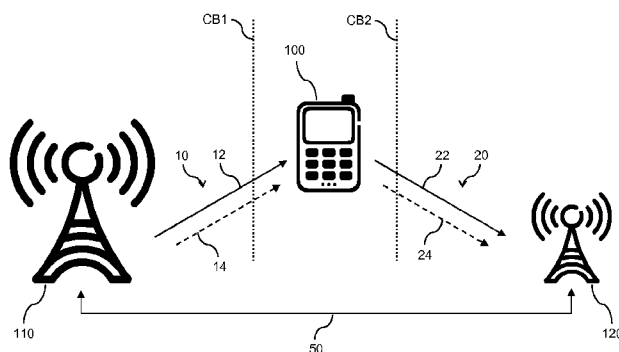

FIG. 3

(57) Abstract: In communication of data between a first base station (110) and a mobile terminal (100), a second base station (120) may handle uplink transmissions (20) from the mobile terminal (100). For this purpose, the first base station (110) sends, to the second base station (120), a request to handle the uplink transmissions (20) from the mobile terminal (100). The handling of the uplink transmissions (20) to be performed by the second base station (120) includes scheduling of the uplink transmissions (20) so as to obtain uplink scheduling information. Via a backhaul link (50), the second base station (120) transmits the uplink scheduling information to the first base station (110). The first base station (110) includes the uplink scheduling information into downlink transmissions (10) to the mobile terminal (100).



## Communication of data using independent downlink and uplink connections

5

### Technical Field

The present invention relates to methods for communication of data using independent downlink (DL) and uplink (UL) connections to a mobile terminal, and to corresponding devices.

10

### Background

In mobile communication networks, such as 3GPP networks (3GPP: Third Generation Partnership Project) there is a continuing need for higher throughputs. In UL communication, i.e., in communication from a mobile terminal to the network, transmit power limitations in mobile terminals and constraints on the UL budget mean that such higher throughputs typically necessitate smaller cell sizes than is typically deployed for present cellular systems. For example, in heterogeneous networks, also referred to as HetNet, conventional base stations (BSs), referred to as Macro BSs, are complemented by further BSs, which are usually deployed closer to the end users, e.g., on street level. As compared to the Macro BSs, these further BSs typically transmit at a lower power. In the following, these further BSs will also be referred to as Pico BSs. The Pico BSs can use carrier frequencies from the same spectrum as the Macro BSs or may use carrier frequencies from another spectrum.

25

In current cellular networks, e.g., 3GPP Long Term Evolution (LTE), cell association is based on a Reference Signal Received Power (RSRP) measurement by the mobile terminal. That is to say, the respective RSRPs as measured for different BSs are used as a basis for selecting a serving BS of the mobile terminal, which then sends DL transmissions to the mobile terminal and receives UL transmissions from the mobile terminal. The RSRP depends on the transmit (Tx) power of the respective BS. In the case of a heterogeneous network deployment, there may be a large imbalance in the Tx power between a Macro BS and a Pico BS. Specifically, Macro BSs usually transmit at a high Tx power level, e.g., 46 dBm, whereas Pico BSs may use a much lower Tx power level, e.g., 30 dBm, or even less. Thus, the difference in Tx power between transmitted reference signals can be 16 dB or more. The RSRP is indicative of a DL channel quality between the BS and the mobile terminal. As

35

compared to that, the UL channel quality between the mobile terminal and the BS depends on the signal damping, also referred to as pathloss, between the mobile terminal and the BS.

5 In conventional homogeneous networks, the BS that provides the highest RSRP is identical to the BS that yields the lowest average pathloss. However, this is not the case in heterogeneous networks. The imbalance in the Tx power among the different types of BSs may lead to a situation where a mobile measures a higher RSRP from a Macro BS, although it is located closer to a Pico BS and its pathloss to the Pico BS is smaller than the pathloss to the Macro BS. In this case, it would be preferable for the mobile terminal to receive data from  
10 the BS with the highest RSRP, i.e., from the Macro BS, and to transmit data to the BS with the lowest pathloss, i.e., to the Pico BS.

Accordingly, in a heterogeneous network conventional RSRP-based cell association may result in suboptimal performance in the UL.

15

A suggested way to balance the performance between DL and UL in a heterogeneous network is to use independent DL and UL connections, i.e., to use one BS for the DL and another BS for the UL. Specifically the UL transmissions of mobile terminals located at a cell border of a Macro BS may then benefit from the improved UL channel quality to a Pico BS  
20 which is closer to the mobile terminal than the Macro BS.

Accordingly, there is a need for techniques which allow for efficiently implementing independent DL and UL connections to a mobile terminal.

## 25 Summary

According to an embodiment of the invention, a method of communicating data between a first base station and a mobile terminal is provided. According to the method, the first base station sends, to a second base station, a request to handle uplink transmissions from the  
30 mobile terminal. The handling of the uplink transmissions to be performed by the second base station comprises scheduling of the uplink transmissions so as to obtain uplink scheduling information. The first base station receives the uplink scheduling information from the second base station. Further, the first base station sends downlink transmissions to the mobile terminal. The downlink transmissions include the downlink scheduling information  
35 received from the second base station.

According to a further embodiment of the invention, a method of assisting in communicating data between a first base station and a mobile terminal is provided. According to the method, a second base station receives, from the first base station, a request to handle uplink transmissions from the mobile terminal. Further, the second base station performs  
5 scheduling of the uplink transmissions from the mobile terminal so as to obtain uplink scheduling information. Further, the second base station sends the uplink scheduling information to the first base station so as to be included into downlink transmissions from the first base station to the mobile terminal.

10 According to a further embodiment of the invention, a base station is provided. The base station comprises a radio interface to send downlink transmissions to a mobile terminal and to receive uplink transmissions from the mobile terminal. Further, the base station comprises a backhaul interface to communicate with a further base station. Moreover, the base station comprises a processor to control operations of the base station. These controlled operations  
15 comprise:

- via the backhaul interface, the base station sending to the further base station a request to handle uplink transmissions from the mobile terminal, said handling of the uplink transmissions comprising scheduling of the uplink transmissions so as to obtain uplink scheduling information;

20 - via the backhaul interface, the base station receiving the uplink scheduling information from the second base station; and

- via the radio interface, the base station sending downlink transmissions to the mobile terminal, said downlink transmissions comprising the uplink scheduling information received from the further base station.

25

According to a further embodiment of the invention, a base station is provided. The base station comprises a radio interface to send downlink transmissions to a mobile terminal and to receive uplink transmissions from the mobile terminal. Further, the base station comprises a backhaul interface to communicate with a further base station. Moreover, the base station  
30 comprises a processor to control operations of the base station. These controlled operations comprise:

- via the backhaul interface, the base station receiving from the further base station a request to handle uplink transmissions from the mobile terminal;

35 - the base station performing scheduling of the uplink transmissions from the mobile terminal so as to obtain uplink scheduling information; and

- via the backhaul interface, the base station sending the uplink scheduling information to the further base station so as to be included into downlink transmissions from the further base station to the mobile terminal.

- 5 According to a further embodiment of the invention, a communication system is provided. The communication system comprises a first base station and a second base station. The communication system is configured to perform operations comprising:
- the first base station sending, to the second base station, a request to handle uplink transmissions from a mobile terminal;
  - 10 - the second base station receiving the request to handle uplink transmissions from the mobile terminal;
  - the second base station performing scheduling of the uplink transmissions from the mobile terminal so as to obtain uplink scheduling information;
  - the second base station sending the uplink scheduling information to the first base station;
  - 15 the first base station receiving the uplink scheduling information; and
  - the first base station sending downlink transmissions to the mobile terminal, said downlink transmissions including the uplink scheduling information received from the second base station.
- 20 According to further embodiments, other methods, devices, or computer program products including program code to be executed by a processor for implementing the methods may be provided.

#### Brief Description of the Drawings

- 25 Fig. 1 schematically illustrates a mobile communication network environment in which concepts of data communication according to an embodiment of the invention can be applied.
- 30 Fig. 2 shows a signaling diagram of a process for establishing independent DL and UL connections according to an embodiment of the invention.
- Fig. 3 schematically illustrates an implementation of independent DL and UL connections according to an embodiment of the invention.
- 35 Fig. 4 shows a signaling diagram of a communication process while using independent DL and UL connections according to an embodiment of the invention.

Fig. 5 schematically illustrates a base station according to an embodiment of the invention.

Fig. 6 shows a flowchart for illustrating a method according to an embodiment of the  
5 invention.

Fig. 7 shows a flowchart for illustrating a further method according an embodiment of the invention.

## 10 Detailed Description of Embodiments

In the following, the invention will be explained in more detail by referring to exemplary  
embodiments and to the accompanying drawings. The illustrated embodiments relate to  
concepts for independent uplink communication from a mobile terminal. In the illustrated  
15 examples, it will be assumed that downlink and uplink communication is implemented  
according to 3GPP LTE. However, it is to be understood that the illustrated concepts may  
also be applied in other types of mobile communication networks.

Fig. 1 schematically illustrates a mobile communication network environment, i.e.,  
20 infrastructure of a mobile communication network, represented by a first base station (BS)  
110 and a second BS 120, and a mobile terminal 100 to be used in the mobile  
communication network. The mobile terminal 100 may be, e.g., a mobile phone, portable  
computer, or other type of user equipment (UE). In the following, the mobile terminal 100 will  
also be referred to as UE. As illustrated, the communication network supports an  
25 independent link mode using independent DL and UL connections to the UE 100. In the  
independent link mode the UE 100 receives DL transmissions 10 from the first BS 110 and  
the second BS 120 receives UL transmissions 20 from the UE 100. For implementing the  
independent link mode, the first BS 110 and the second BS 120 communicate via a backhaul  
link 50. However, the communication network also supports a conventional mode in which  
30 the UE 100 receives DL transmissions from one of the BSs 110, 120 and this BSs 110, 120  
also receives the UL transmissions from the UE 100.

As further illustrated, the mobile communication network is based on a heterogeneous  
network deployment in which the first BS 110 corresponds to a Macro BS and the second BS  
35 120 corresponds to a Pico BS. This means that the second BS 120 transmits at a lower Tx  
power than the first BS 110. In accordance with the illustrated 3GPP LTE scenario, the BSs  
110, 120 may each correspond to an evolved Node B (eNB) and the DL and UL

transmissions 10, 20 may be transmitted across the Uu radio interface. The backhaul link 50 may be established by directly connecting the BSs 110, 120, e.g., via the X2 interface, or by indirectly connecting the BSs 110, 120, e.g., via one or more intermediate nodes using several X2 and/or S1 interfaces. The backhaul link 50 that can be wire based, e.g., using optical fiber, twisted pair copper lines, and/or coaxial lines, or can be wireless, e.g., using microwave transmission, Wireless Local Area Network (WLAN), or LTE. In some scenarios, the backhaul link 50 may also be implemented by a combination of wire based transmission and wireless transmission, e.g., by using any combination of the above-mentioned examples of wire based and wireless technologies.

5

Whether the conventional mode or the independent link mode is used may be selected, e.g., on the basis of the pathloss from the UE 100 to the second BS 120. More specifically, the selection may be on the basis of the difference between the pathloss from the UE 100 to the second BS 120 and the pathloss from the UE 100 to the first BS 110. Concepts of selecting between the conventional mode and the independent link mode will now be further explained by referring to illustrative cell border lines CB1 and CB2 in Fig. 1.

10

The cell border line CB1 illustrates a cell border between the first and second BSs 110, 120 when assuming a selection mechanism on the basis of the pathloss. In this pathloss-based selection mechanism, the BS having the lowest pathloss would be selected for handling communications with the UE 100. The pathloss-based selection mechanism is favorable in view of UL performance. The cell border line CB2 illustrates a cell border between the first and second BSs 110, 120 when assuming a selection mechanism on the basis of received signal quality at the UE 100, e.g., on the basis of the RSRP. In this received-signal quality based selection mechanism, the BS offering the highest received signal quality at the UE would be selected for communicating with the UE 100. The received-signal quality based selection mechanism is favorable in view of DL performance.

15

20

25

In the illustrative scenario of Fig. 1, the UE 100 is located in a transition area between the cell border lines CB1 and CB2. This means that, the pathloss-based selection mechanism, which is favorable in view of UL performance, would select the second BS 120, whereas the received-signal quality based selection mechanism, which is favorable in view of DL performance, would select the first BS 110. In this situation, overall performance can be improved by selecting the independent link mode.

30

35

The pathloss PL from a UE to a BS may be estimated by the difference between the RSRP at the UE and the Tx power at the BS. In this case, it can be seen that the UE 100 being in

the transition area between the first BS 110 and the second BS 120 means that the RSRP of the first BS 110, denoted by RSRP1, the RSRP of the second BS 120, denoted by RSRP2, the Tx power of the first BS 110, denoted by PTx1, and the Tx power of the second BS 120, denoted by PTx2, satisfy the relation:

5

$$\text{RSRP1} - \text{RSRP2} \leq \text{PTx1} - \text{PTx2}. \quad (1)$$

Relation (1) may therefore be used to identify whether a particular UE is located in the transition area between two BSs. The needed RSRPs can be obtained from measurement reports. The Tx powers can be obtained, e.g., from Operations and Maintenance data or by using exchanging messages with neighboring BSs.

Fig. 2 shows a signaling diagram for schematically illustrating a process for establishing the independent DL and UL connections to the UE. More specifically, Fig. 2 illustrates communication between the first BS 110 and the second BS 120. In the process of Fig. 2, it is assumed that the first BS 110 is the serving BS 110 of one or more UEs, i.e., controls communications with respect to these UEs. This selection may be based on a conventional selection mechanism, e.g., on the basis of a received signal quality at the UE such as represented by the RSRP.

20

At step 201, the first BS 110 identifies one or more transition UEs among the UEs served by the first BS 110. As explained above, the transition UEs are UEs for which the first BS 110 offers the highest received signal quality at the UE, but another BS provides a lower pathloss than the first BS 110. The transition UEs may be identified using relation (1). Further, the transition UEs may be identified by comparing results of a received-signal quality based selection mechanism, e.g., on the basis of the RSRP, to results of a pathloss-based selection mechanism. Accordingly, both types of selection may be applied, and if for a certain UE the received-signal quality based selection mechanism indicates that the first BS 110 should be selected, whereas the pathloss-based selection mechanism indicates that another BS should be selected, this UE may be identified as a transition UE. Here, it should be noted that if for a certain UE the received-signal quality based selection mechanism indicates that another BS than the first BS 110 should be selected, this UE may be identified as a candidate for a handover to the other BS. In some scenarios, also a transition UE may be identified as a candidate for a handover, e.g., if for a certain UE the received-signal quality based selection mechanism indicates that another BS than the first BS 110 should be selected, but this other BS is different from a BS indicated by the pathloss-based selection mechanism. For

35

example, the pathloss-based selection mechanism may indicate a still further BS or may indicate the first BS 110.

Having identified at least one transition UE, e.g., the UE 100 as illustrated in Fig. 1, a BS for  
5 handling UL transmissions from the transition UE is selected at step 202. In the illustrated  
example, the second BS 120 is selected. The selection may be based on the pathloss. More  
specifically, the second BS 120 may be selected on the basis of a difference between the  
pathloss from the transition UE to the first BS 110 and the pathloss from the transition UE to  
10 the second BS 120. For example, the second BS 120 may be selected if it provides a lower  
pathloss from the transition UE than the first BS 110. If there are multiple BSs providing a  
lower pathloss from the transition UE than the first BS 110, the second BS 120 may be  
selected among these multiple BSs as the one providing the lowest pathloss from the  
transition UE. Further, in view of relation (1), the second BS 120 may also be selected on the  
15 basis of a difference between the Tx power of the first BS 110 and the Tx power of the  
second BS 120.

It should be noted that the selections of steps 201 and 202 may be combined using a single  
selection mechanism. For example, the pathloss-based selection mechanism of step 201  
may be used to identify one or more transition UEs, and at the same time the BS for handling  
20 UL transmissions from the respective transition UE. In particular, the other BS as indicated  
by the pathloss-based selection mechanism may also be selected as the BS for handling UL  
transmissions from the respective transition UE.

The first BS 110 then sends a message 203 to the second BS 120. The message 203  
25 includes a request to handle UL transmissions from one or more of the UEs which were  
identified as being in the transition area between the first BS 110 and the second BS 120.  
The request may include or be accompanied by additional information, e.g., information for  
identifying the UE or UEs to which the request pertains, information on reference signals  
used by the UE or UEs to which the request pertains, UL scheduling information of the UE or  
30 UEs to which the request pertains, information on characteristics of the UE or UEs to which  
the request pertains, and/or information on an expected load associated with requested  
handling of the UL transmissions. Using the received information, the second BS 120 may  
perform measurements on the UL transmissions from the identified UEs. For example, the  
second BS 120 may determine a timing advance offset needed to synchronize the UL  
35 transmissions from the identified UE or UEs with other UL transmissions from UEs already  
handled by the second BS 120.

The second BS 120 may reject the request, e.g., if capacity available at the second BS 120 is not sufficient for the requested handling of UL transmissions. Otherwise, the second BS 120 may accept the request. The second BS 120 may indicate the rejection or acceptance of the request by sending a message 204 to the first BS 110. The message 204 may also  
5 include information on the cell load or on the amount of resources that the second BS 120 is willing to provide for handling the UL transmissions. Further, the message 204 may include information about a timing advance offset needed to synchronize the UL transmissions of a UE to which the request of message 203 pertains with UL transmissions of other UEs already handled by the second BS 120.

10

If the message 204 indicates acceptance of the request, the first BS 110 may send a further message 205 to the second BS 120. The message 205 may confirm the setup of independent DL and UL connections and/or may include UE specific information to be used by the second BS 120 in handling the UL transmissions. For example, this UE specific  
15 information may include a reference signal (RS) of the UE or UEs from which UL transmissions are to be handled, e.g., demodulation RS and/or sounding RS, and/or a UE specific scrambling sequence of the UE or UEs from which UL transmissions are to be handled. In modifications of the above process, the UE specific information may also be included in the message 203.

20

In an embodiment, the second BS 120 measures on UL transmissions from a UE to which the request of message 203 pertains the timing advance offset needed for the UL transmissions from this UE to be synchronized with UL transmissions from other UEs already handled by the second BS 120. In message 204, the second BS 120 may then include this  
25 measured timing advance offset. On the basis of the received timing advance offset, the first BS 110 may decide to cancel the procedure by not sending the conformation message 205, e.g., because the received timing advance offset does not comply with its own timing advance offset.

30

In the above process, the received-signal quality based selection mechanism may be the basis of first selecting the serving BS. In particular, each UE may be associated with its serving BS using conventional RSRP-based cell association. Among its served UEs, each serving BS may then identify those which are in the transition area to another BS and set up the independent UL connection to the other BS. In this way, the use of independent DL and  
35 UL connections can be kept transparent to the UEs.

Fig. 3 schematically illustrates the implementation of the independent DL and UL connections according to an embodiment of the invention. In Fig. 3, elements which correspond to those of Figs. 1 and 2 have been designated by the same reference signs, and reference is made also to the corresponding description in connection with Figs. 1 and 2. As  
5 illustrated, the first base station 110 sends DL transmissions 10 to the UE 100. The DL transmissions 10 include DL payload data 12 and DL control data 14. In accordance with the illustrated LTE scenario, the UL payload data 12 may be sent on a Physical Downlink Shared Channel (PDSCH) and the DL control data 14 may be sent on a Physical Downlink Control Channel (PDCCH). Further, the second base station 120 receives UL transmissions 20 from the UE 100. The UL transmissions 20 include UL payload data 22 and UL control data 24. In  
10 accordance with the illustrated LTE scenario, the UL payload data 22 may be sent on a Physical Uplink Shared Channel (PUSCH) and the UL control data 24 may be sent on a Physical Uplink Control Channel (PUCCH). The first BS 110 does not monitor the UL transmissions 20 from the UE 100. The second BS 120 in turn does not send any DL  
15 transmissions to the UE.

Accordingly, in the scenario of Fig. 3 it is the second BS 120 which receives not only the UL payload data 22 but also the UL control data 24, whereas the first BS 110 still transmits the DL payload data 12 and the DL control data 14. Using the backhaul link 50, the second BS  
20 120 may then forward at least a part of the control data 24 and optionally also the payload data 22 to the first BS 110. In particular, the second BS 120 may forward control data which are used by the first BS 110 for controlling the DL transmissions 10 to the UE 100. Further, the second BS 120 may also generate control data from the received UL transmissions 20 and send the generated control data to the first BS 110 via the backhaul link. The control  
25 data transmitted from the second BS 120 to the first BS 110 may include measurement reports generated by the UE 100, e.g., as represented by a Precoding Matrix Indicator (PMI), a Channel Quality Indicator (CQI), a RSRP, a Received Signal Strength Indicator (RSSI), a Rank Indicator (RI), Channel State Information (CSI), and/or a mobility report. Further, control data transmitted from the second BS 120 to the first BS 110 may include messages  
30 for acknowledging receipt of a DL transmission 10 or for acknowledging receipt of an UL transmission 20, e.g., as represented by a positive acknowledgement (ACK) message or negative acknowledgement (NACK) message of the Hybrid Automatic Repeat Request (HARQ) protocol. Here, it is to be noted that an acknowledgement message for a DL transmission 10 would be generated by the UE 100, transmitted to the second BS 120 with  
35 the UL control data 24, and then forwarded from the second BS 120 to the first BS 110 via the backhaul link 50. As compared to that, an acknowledgement message for an UL

transmission 20 would be generated by the second BS 120, transmitted to the first BS 110, and then forwarded by the first BS 110 to the UE 100 with the DL control data 14.

When handling the UL transmissions 20 from the UE 100, the second BS 120 is responsible  
5 for handling scheduling of the UL transmissions 20 from the UE 100. Scheduling of the UL transmissions 20 may in particular include allocation of time/frequency resources and/or Tx power adjustment for the UL transmissions 20. Further, the scheduling information may also include a timing advance offset to correct the start of a UL transmission 20. Scheduling of the DL transmissions 10 to the UE 100, which may in particular include allocation of  
10 time/frequency resources and Tx power adjustment for the DL transmissions 10, is turn accomplished by the first BS 110, but may take into account the control data received from the second BS 120, e.g., measurement reports or acknowledgement messages for DL transmissions. Scheduling of the UL transmissions 20 by the second BS 120 allows for efficiently implementing the independent DL and UL connections because the BS receiving  
15 the UL transmissions 20 also performs the scheduling for these UL transmissions 20. Scheduling processes as already provided for UL transmissions of UEs served by the second BS can be reused. However, the obtained UL scheduling information, e.g., time/frequency resource allocations, Tx power adjustment, and/or timing advance offset, is not transmitted directly from the second BS 120 to the UE 100, but rather sent to the first BS  
20 110 so as to be forwarded to the UE 100 with the DL control data 14. For the UE 100, the independent implementation of the DL and UL connections can remain transparent, i.e., the UE 100 may operate in the same way as if it would communicate with the first BS 110 only.

Fig. 4 shows a signaling diagram of a communication process while using independent DL  
25 and UL connections, e.g., independent DL and UL connections as established using the process of Fig. 2 and implemented as explained in connection with Fig 3.

In the illustrated process, the second BS 120 monitors UL transmissions from the UE 100. As illustrated, the second BS 120 receives a particular UL transmission 401 from the UE 100.  
30 Reception (Rx) processing is illustrated at step 402. The reception processing may include, e.g., demodulation and conversion to digital samples.

At step 403, the second BS 120 performs decoding of the received UL transmission 401. The decoding process may also include verifying integrity of reception, e.g., by performing a  
35 cyclic redundancy check (CRC). The decoding process may be based on a UE specific scrambling sequence used by the UE 100.

The second BS 120 then transmits a message 405 to the first BS 110. The message 405 may include control data generated by the second BS 120 in the decoding process, in particular acknowledgement messages. More specifically, if the integrity of reception was verified at step 403, the message 405 may include a HARQ protocol ACK message, and if  
5 the integrity of reception was not verified at step 403, the message 405 may include a HARQ protocol NACK message. The message 405 may also include decoded payload data. By sending the decoded payload data to the first BS 110, the first BS 110 may be the BS to supply the UL payload data to the network, which means that also from the network perspective the first BS 110 appears as the serving BS for the UE 100.

10

At step 406, the second BS 120 selects control data from the received UL transmission 401. More specifically, the second BS 120 may select acknowledgement messages for DL transmissions generated by the UE 100 and/or measurement reports generated by the UE 100. The second BS 120 then sends the selected control data with a message 407 to the first  
15 BS 110. The first BS 110 may use the received control data for controlling DL transmissions to the UE 100, e.g., for performing scheduling of DL transmissions.

20

At step 408, the second BS 120 performs scheduling of UL transmissions so as to obtain UL scheduling information. The UL scheduling information may in particular include allocation of  
time/frequency resources, Tx power adjustment, and/or timing advance offset for one or more future UL transmission by the UE 100. The scheduling of UL transmissions may be based on channel quality measurements on the UL connection from the UE 100 to the second BS 120. Since the second BS 120 itself monitors the UL transmissions from the UE 100, the channel quality measurements can be efficiently and precisely performed by the  
25 second BS 120 and be used directly as input parameters of the scheduling process. With message 409, the second BS 120 sends the UL scheduling information to the first BS 110.

25

The first BS 110 receives the message 409 with the UL scheduling information from the second BS 120 and includes the UL scheduling information into a DL transmission 410 of  
30 control data. The DL transmission may also include other control data to be forwarded to the UE 100, such as the acknowledgement message received with messages 405, or control data generated by the first BS 110, e.g., control data pertaining to DL transmissions.

30

It is to be understood that information as transmitted with messages 405, 407 and 409 may  
35 also be combined into a smaller number of messages. For example, only a single message including the information as transmitted with messages 405, 407 and 409 may be sent from the second BS 120 to the first BS 110. Further, the second BS 120 may perform scheduling

35

of the UL transmissions at any suitable time, e.g., before the selection of step 406, before the decoding of step 403, or before the reception of step 402.

Fig. 5 schematically illustrates exemplary structures for implementing the above-described  
5 concepts in a BS, e.g., in the first BS 110 of Figs. 1 to 4 or in the second BS 120 of Figs. 1 to 4.

In the illustrated structure, the BS includes a radio interface 130 for transmitting DL  
10 transmissions and/or for receiving UL transmissions. It is to be understood that for implementing transmit functionalities the interface 130 will include one or more transmitters, and that for implementing receive functionalities the interface 130 will include one or more receivers. The interface 130 may correspond to the Uu radio interface according to 3GPP LTE. The interface 130 is capable of receiving and decoding UL transmissions not only from UEs served by the BS, but also from UEs served by another BS. Further, the BS includes a  
15 backhaul interface 140 for communicating with one or more other BSs, e.g., for implementing the backhaul link 50 as illustrated in Figs 1 and 3.

Further, the BS includes a processor 150 coupled to the interface 130 and a memory 160  
coupled to the processor 150. The memory 160 may include a read-only memory (ROM),  
20 e.g. a flash ROM, a random-access memory (RAM), e.g., a Dynamic RAM (DRAM) or static RAM (SRAM), a mass storage, e.g., a hard disk or solid state disk, or the like. The memory 160 includes suitably configured program code to be executed by the processor 150 so as to implement the above-described functionalities of the BS. More specifically, the memory 160 may include control module 170 for controlling communication with respect to one or more  
25 UE, e.g., the UE 100 of Figs. 1 to 4. The control module 170 may further be configured to control generating, sending and receiving of messages as described in connection with Figs. 2 and 4. Moreover, the control module 170 may also be configured to control channel quality measurements performed by the BS, in particular channel quality measurements on UL connections from UEs which are not served by the BS. Further, the memory 160 may include  
30 a DL scheduling module 172 for scheduling DL transmissions of a UE and/or an UL scheduling module 174 for scheduling UL transmissions of a UE as explained in connection with Figs. 3 and 4. In particular, the UL scheduling module 174 may be configured to accomplish UL scheduling not only for UEs served by the BS, but also for UEs served by another BS, when handling UL transmissions from the UEs served by the other BS. Further,  
35 the memory 160 may also include a selection module 176 for identifying or selecting transition UEs and/or for selecting other BSs for handling UL transmissions of a UE served by the BS, e.g., as explained in connection with Figs. 1 and 2.

It is to be understood that the structure as illustrated in Fig. 5 is merely schematic and that the BS may actually include further components which, for the sake of clarity, have not been illustrated, e.g., further interfaces. Also, it is to be understood that the memory 160 may include further types of program code modules, which have not been illustrated. For example, the memory 160 may include program code modules for implementing typical functionalities of a BS. According to some embodiments, also a computer program product may be provided for implementing concepts according to embodiments of the invention, e.g., a computer-readable medium storing the program code and/or other data to be stored in the memory 160.

Fig. 6 shows a flowchart for schematically illustrating a method according to an embodiment of the invention. The method may be used in the first BS 110 of Fig. 1 to 4 for implementing the above-described processes using independent DL and UL connections.

At step 610, a first BS sends a request to a second BS. By means of the request, the second BS is requested to handle UL transmissions from a UE. The first BS may be the serving BS of the UE, i.e., may control communications with respect to the UE. The first BS may be the first BS 110 of Figs. 1 to 4, the second BS may be the second BS 120 of Figs. 1 to 4, and the UE may be the UE 100 of Figs. 1, 3 and 4. The request to handle UL communications from the UE may be sent via a backhaul link, e.g., the backhaul link 50 of Figs. 1 and 3. The backhaul link may be established across respective backhaul interfaces of the first and second BSs, such as the backhaul interface 140 of Fig. 5. The requested handling of UL transmissions includes scheduling of the UL transmissions so as to obtain UL scheduling information, such as a time/frequency resource allocation and/or Tx power adjustment used for the UL transmissions. In addition, the requested handling of the UL transmissions typically also includes reception and decoding of the UL transmissions. Before sending the request, the first BS may select the second BS from a plurality of BSs, e.g., using selection mechanisms as described in connection with Figs. 1 and 2.

Optionally, the first BS may receive a message indicating whether the request was accepted by the second BS, e.g., the message 204 of Fig. 2. Further, the first BS may transmit additional UE specific information to the second BS, which may be accomplished along with the request to handle UL transmissions or in one or more separate messages, e.g., the message 205 of Fig. 2. The additional UE specific information may be used by the second BS in the requested handling of UL transmissions, and include parameters such as UE specific reference signals.

At step 620, the UL scheduling information is received from the second BS. This may again be accomplished via the backhaul link. The UL scheduling information may be received in a dedicated message, e.g., the message 409 of Fig. 4, or may be received along with other  
5 information.

At step 630, control data may be received from the second BS, which may again be accomplished via the backhaul link, such as in messages 405 and 407 of Fig. 4. The control data may include measurement reports generated by the UE. Further, the control data may  
10 include messages for acknowledging receipt of a DL transmission or for acknowledging receipt of an UL transmission, e.g., HARQ protocol ACK messages or HARQ protocol NACK messages. The measurement reports and/or messages for acknowledging receipt of a DL transmission may be used by the first BS for performing scheduling of DL transmissions to the UE.

At step 640, the received UL scheduling information is included into a DL transmission to the UE, e.g., into a DL transmission of control data. This DL transmission may also include other control data, e.g., the messages for acknowledging receipt of a UL transmission received at  
15 step 630.

Fig. 7 shows a flowchart for schematically illustrating a method according to a further embodiment of the invention. The method may be used in the second BS 120 of Fig. 1 to 4 for implementing the above-described processes using independent DL and UL connections.  
20

At step 710, a request from a first BS is received by a second BS. By means of the request, the second BS is requested to handle UL transmissions from a UE. The first BS may be the serving BS of the UE, i.e., may control communications with respect to the UE. The first BS may be the first BS 110 of Figs. 1 to 4, the second BS may be the second BS 120 of Figs. 1 to 4, and the UE may be the UE 100 of Figs. 1, 3 and 4. The request to handle UL  
25 communications from the UE may be sent via a backhaul link, e.g., the backhaul link 50 of Figs. 1 and 3. The backhaul link may be established across respective backhaul interfaces of the first and second BSs, such as the backhaul interface 140 of Fig. 5. The requested handling of UL transmissions includes scheduling of the UL transmissions so as to obtain UL scheduling information, such as a time/frequency resource allocation and/or Tx power  
30 adjustment used for the UL transmissions. In addition, the requested handling of the UL transmissions includes reception and typically also decoding of the UL transmissions.

Optionally, the second BS may send a message indicating whether the request was accepted, e.g., the message 204 of Fig. 2. Further, the second BS may receive additional UE specific information from the first BS, which may be accomplished along with the request to handle UL transmissions or in one or more separate messages, e.g., the message 205 of  
5 Fig. 2. The additional UE specific information may be used by the second BS in the requested handling of UL transmissions, and include parameters such as UE specific reference signals.

At step 720, the second BS accomplishes scheduling of the UL transmissions from the UE so  
10 as to obtain the UL scheduling information. For this purpose, the second BS may also perform channel quality measurements on the UL connection from the UE.

At step 730, the second BS sends the UL scheduling information to the first BS. This may again be accomplished via the backhaul link. The UL scheduling information may be sent in  
15 a dedicated message, e.g., the message 409 of Fig. 4, or may be sent along with other information.

At step 740, the second BS receives the UL transmissions from the UE. Typically, this also includes decoding and integrity verification of the received UL transmissions. On the basis of  
20 the received UL transmissions, the second BS may generate control data to be sent to the first BS, e.g., messages for acknowledging receipt of the UL transmissions. Further, the second BS may also extract control data from the received UL transmissions, e.g., measurement reports from the UE.

At step 750, the second BS may transmit the generated or extracted control data to the first  
25 BS, which may again be accomplished via the backhaul link, such as in messages 405 and 407 of Fig. 4.

The methods of Figs. 6 and 7 may be combined with each other in a communication system  
30 including the first BS and the second BS.

As can be seen, by using the above described concepts the overall performance of DL and UL connections in a heterogeneous network can be improved. Further, independent DL and UL connections can be implemented in a manner which is transparent to the UE and without  
35 excessive impact on existing technologies.

It is to be understood that the examples and embodiments as explained above are merely illustrative and susceptible to various modifications. For example, the concepts could be used in other types of mobile communication network. For example, the concepts may not only be used in heterogeneous network deployments using Macro and Pico BSs, but also in  
5 other network deployments in which imbalances between DL and UL connections may occur. Further, it is to be understood that the above concepts may be implemented by using correspondingly designed software in existing BSs, or by using dedicated hardware in the BSs.

Claims

1. A method of communicating data between a first base station (110) and a mobile terminal  
5 (100), the method comprising:  
the first base station (110) sending, to a second base station (120), a request (203) to handle  
uplink transmissions (20) from the mobile terminal (100), said handling of the uplink  
transmissions (20) comprising scheduling of the uplink transmissions (20) so as to obtain  
uplink scheduling information;  
10 the first base station (110) receiving the uplink scheduling information from the second base  
station (120); and  
the first base station (110) sending downlink transmissions (10) to the mobile terminal (100),  
said downlink transmissions (10) including the uplink scheduling information received from  
the second base station (120).  
15
2. The method according to claim 1, comprising:  
the first base station (110) selecting the second base station (120) from a plurality of base  
stations.
- 20 3. The method according to claim 2,  
wherein the first base station (110) selects the second base station on the basis of a  
parameter which is indicative of a path loss for the uplink transmissions (20) from the mobile  
terminal to the second base station (120).
- 25 4. The method according to claim 2 or 3,  
wherein the first base station (110) selects the second base station on the basis of a  
parameter which is indicative of a difference between the path loss for the uplink  
transmissions (20) from the mobile terminal to the second base station (120) and the path  
loss for uplink transmissions from the mobile terminal to the first base station (120).  
30
5. The method according to any one of claims 2 to 4,  
wherein the first base station (110) selects the second base station (120) on the basis of a  
parameter which is indicative of a difference between a transmit power of the first base  
station (110) and a transmit power of the second base station (120).  
35
6. The method according to any one of the preceding claims, comprising:

the first base station (110) performing scheduling of the downlink transmissions (10) to the mobile terminal (100).

7. The method according to claim 6, comprising:

5 the first base station (110) receiving control data from the second base station (120); and  
the first base station (110) performing said scheduling of the downlink transmissions (10) on  
the basis of the control data received from the second base station (120).

8. The method according to any one of the preceding claims, comprising:

10 the second base station (120) receiving, from the first base station (110), the request (203) to  
handle uplink transmissions (20) from the mobile terminal (100);  
the second base station (120) performing scheduling of the uplink transmissions (20) from  
the mobile terminal (100) so as to obtain the uplink scheduling information; and  
the second base station (120) sending the uplink scheduling information to the first base  
15 station (110) so as to be included into the downlink transmissions from the first base station  
(110) to the mobile terminal (100).

9. A method of assisting in communicating data between a first base station (110) and a  
mobile terminal (100), the method comprising:

20 a second base station (120) receiving, from the first base station (110), a request to handle  
uplink transmissions (20) from the mobile terminal (100);  
the second base station (120) performing scheduling of the uplink transmissions (20) from  
the mobile terminal (100) so as to obtain uplink scheduling information; and  
the second base station (120) sending the uplink scheduling information to the first base  
25 station (110) so as to be included into downlink transmissions (10) from the first base station  
(110) to the mobile terminal (100).

10. The method according to claim 8 or 9, comprising:

30 the second base station (120) generating control data on the basis of the uplink  
transmissions (20) received from the mobile terminal (100); and  
the second base station (120) sending the control data to the first base station (110).

11. The method according to claim 10,

35 wherein the control data include measurement reports generated by the mobile terminal  
(100).

12. The method according to claim 10 or 11,

wherein the control data include one or more messages for acknowledging receipt of a downlink transmission (10) or for acknowledging receipt of an uplink transmission (20).

13. A base station (110), comprising:

- 5 a radio interface (130) to send downlink transmissions to a mobile terminal (100) and to receive uplink transmissions from the mobile terminal (100);  
a backhaul interface (140) to communicate with a further base station; and  
a processor (150) to control operations of the base station,  
wherein said operations of the base station (110) comprise:  
10 via the backhaul interface (140), the base station (110) sending to the further base station (120) a request (203) to handle uplink transmissions (20) from the mobile terminal, said handling of the uplink transmissions (20) comprising scheduling of the uplink transmissions (20) so as to obtain uplink scheduling information;  
via the backhaul interface (140), the base station (110) receiving the uplink scheduling  
15 information from the second base station (120); and  
via the radio interface (130), the base station (110) sending downlink transmissions (10) to the mobile terminal (100), said downlink transmissions (10) comprising the uplink scheduling information received from the further base station (120).

- 20 14. The base station (110) according to claim 13,  
wherein the base station (110) is configured to operate as the first base station of the method as defined in any one of claims 1 to 12.

15. A base station (120), comprising:

- 25 a radio interface (130) to send downlink transmissions to a mobile terminal (100) and to receive uplink transmissions from the mobile terminal (100);  
a backhaul interface (140) to communicate with a further base station (110); and  
a processor (150) to control operations of the base station (120),  
wherein said operations of the base station (120) comprise:  
30 via the backhaul interface (140), the base station (120) receiving from the further base station (110) a request (203) to handle uplink transmissions (20) from the mobile terminal (100);  
the base station (120) performing scheduling of the uplink transmissions (20) from the mobile terminal (100) so as to obtain uplink scheduling information; and  
35 via the backhaul interface (140), the base station (120) sending the uplink scheduling information to the further base station (110) so as to be included into downlink transmissions (10) from the further base station (110) to the mobile terminal (100).

16. The base station (120) according to claim 15,  
wherein the base station (120) is configured to operate as the second base station of the  
method as defined in any one of claims 1 to 12.

5

17. A communication system comprising a first base station (110) and a second base station  
(120);

wherein the communication system is configured to perform operations comprising:

10 the first base station (110) sending, to the second base station (120), a request (203) to  
handle uplink transmissions from a mobile terminal (100);

the second base station (120) receiving the request (203) to handle uplink transmissions (20)  
from the mobile terminal (100);

the second base station (120) performing scheduling of the uplink transmissions (20) from  
the mobile terminal (100) so as to obtain uplink scheduling information;

15 the second base station (120) sending the uplink scheduling information to the first base  
station (110);

the first base station (110) receiving the uplink scheduling information; and

20 the first base station (110) sending downlink transmissions (10) to the mobile terminal (100),  
said downlink transmissions (10) including the uplink scheduling information received from  
the second base station (120).

18. The communication system according to claim 17,

wherein the communication system is configured to operate in accordance with a method  
according to any one of claims 1 to 12.

25

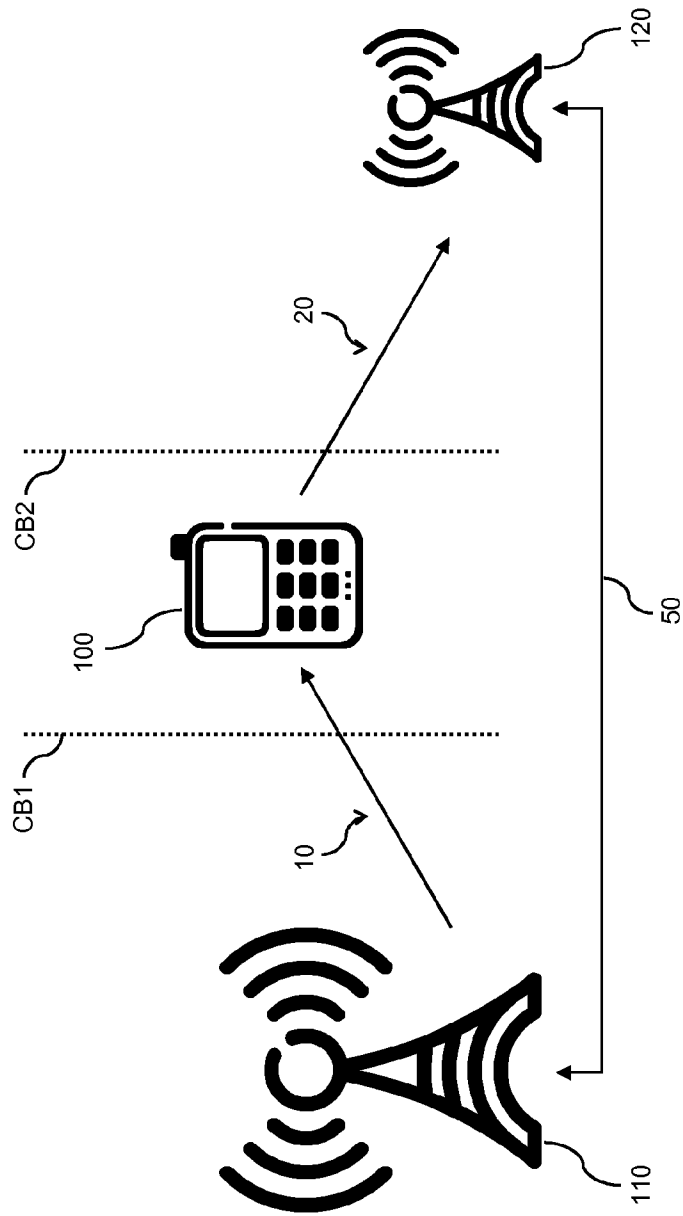

FIG. 1

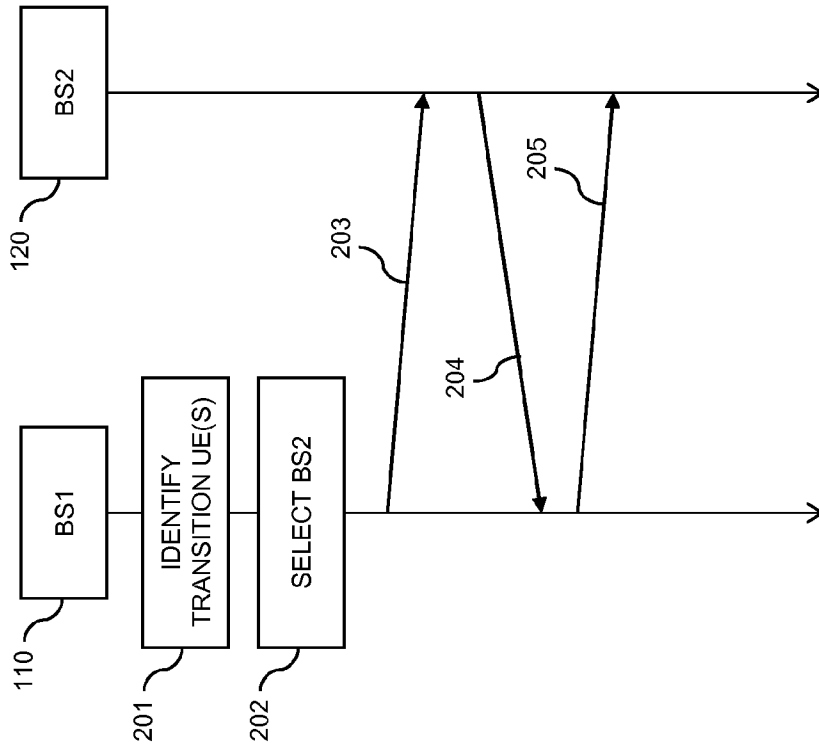

FIG. 2

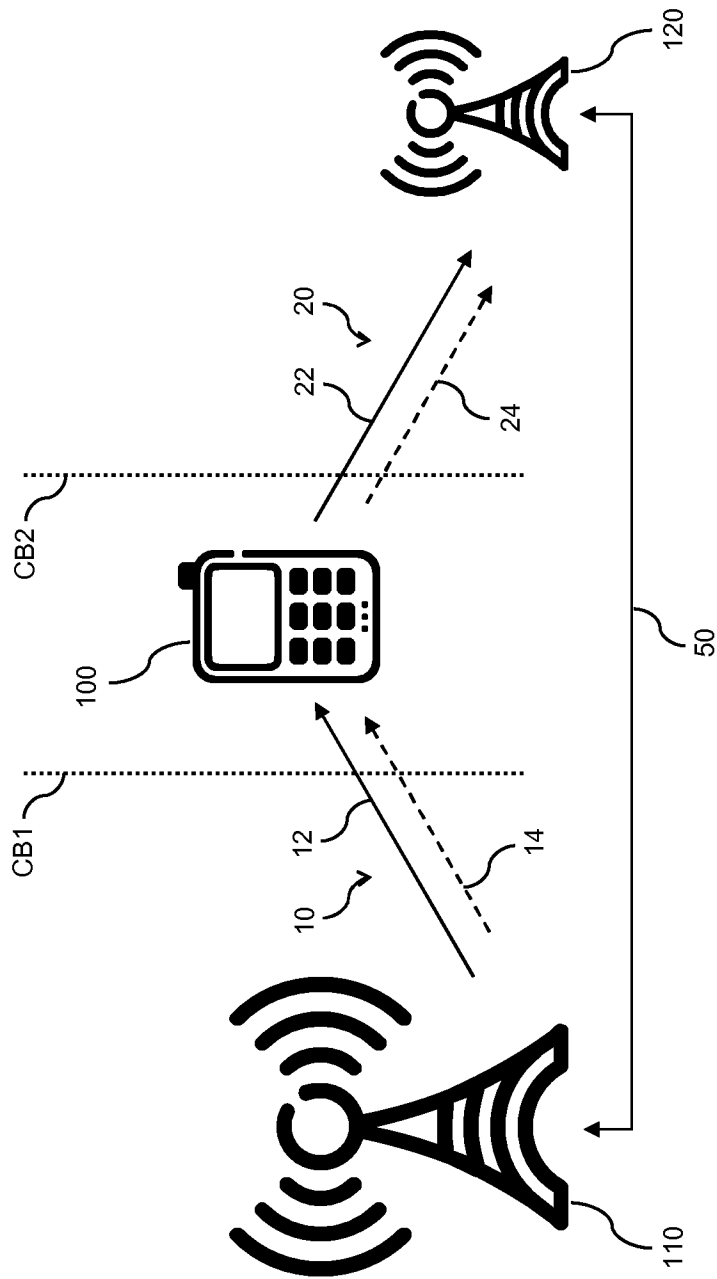

FIG. 3

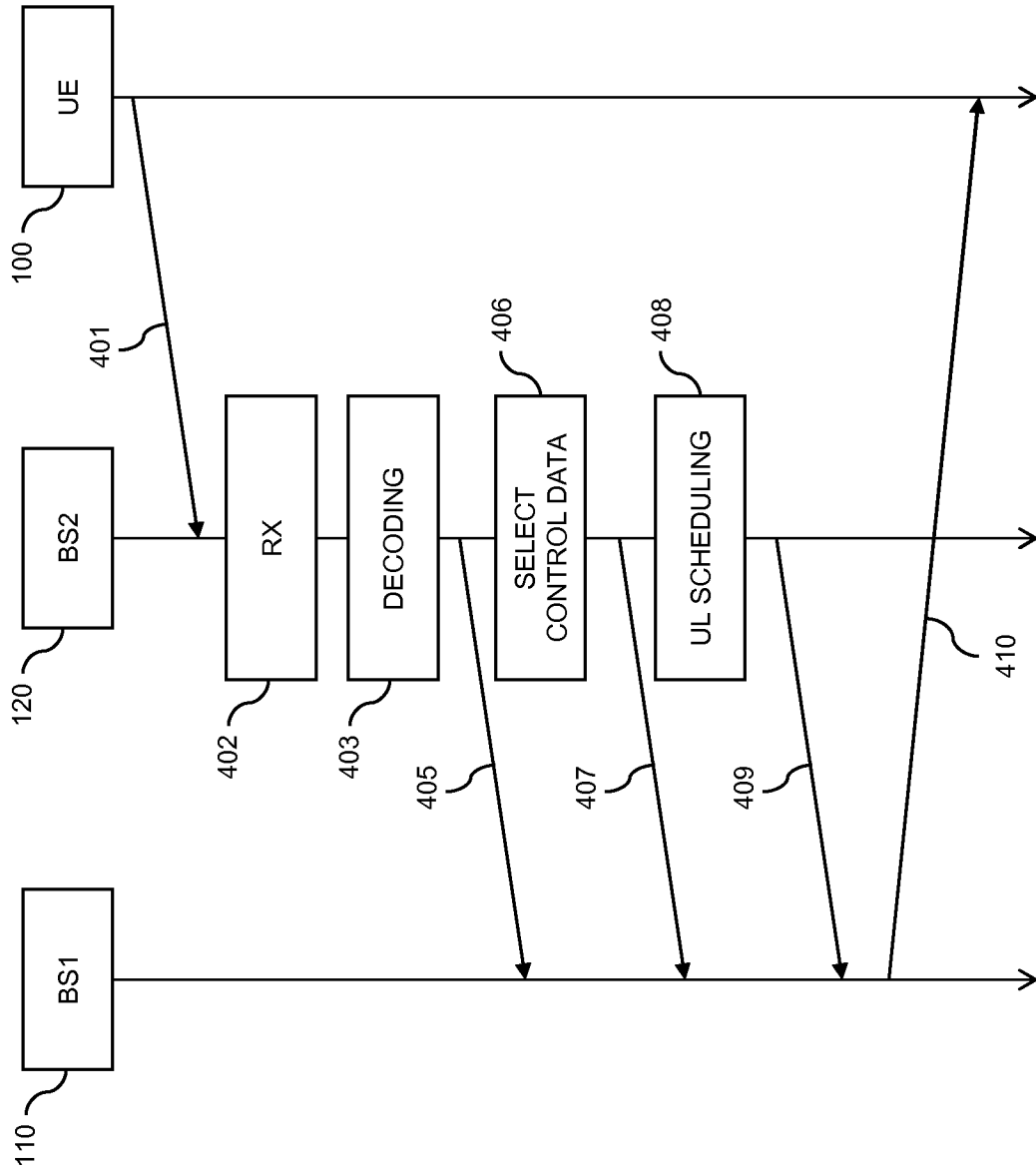

FIG. 4

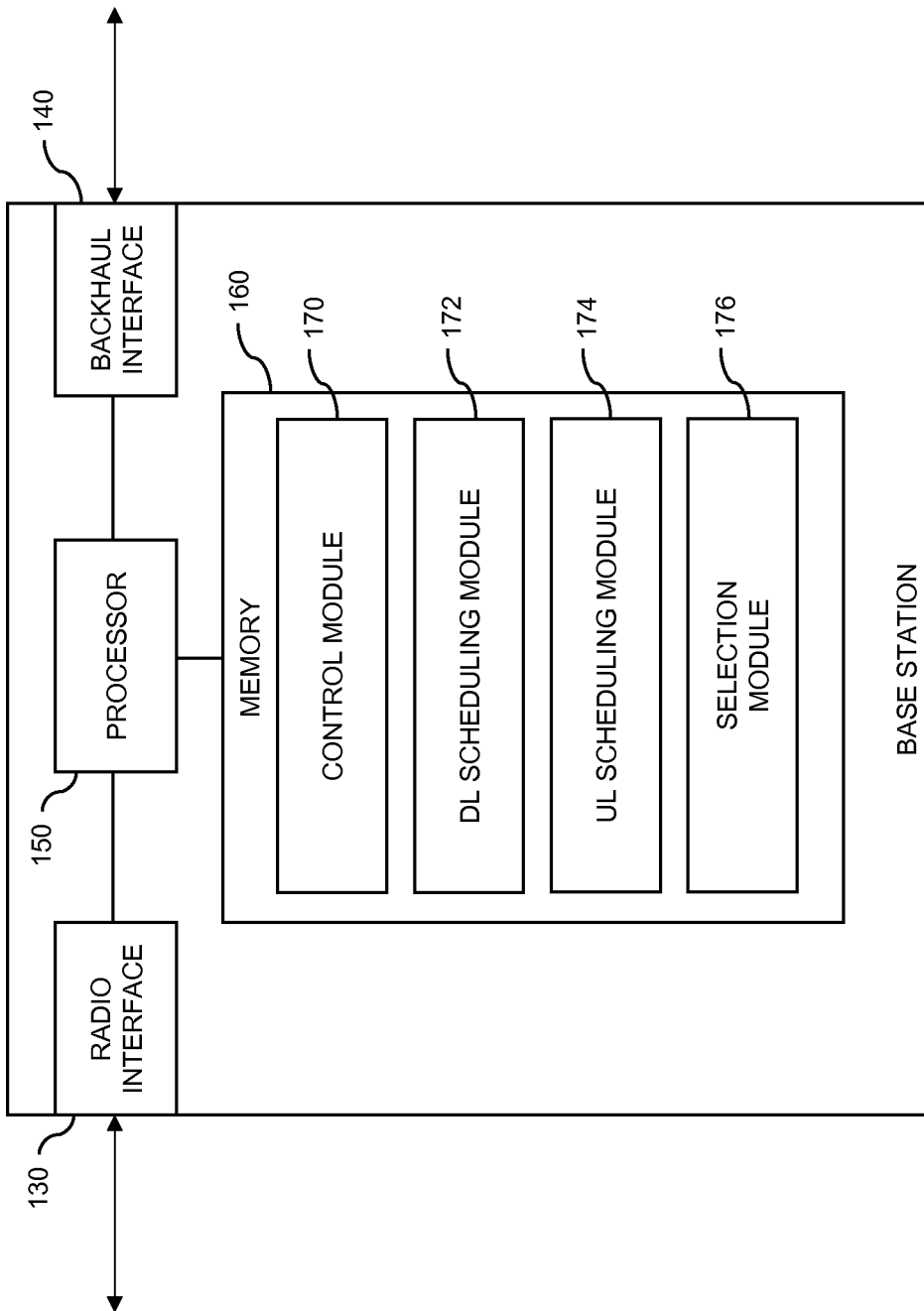

FIG. 5

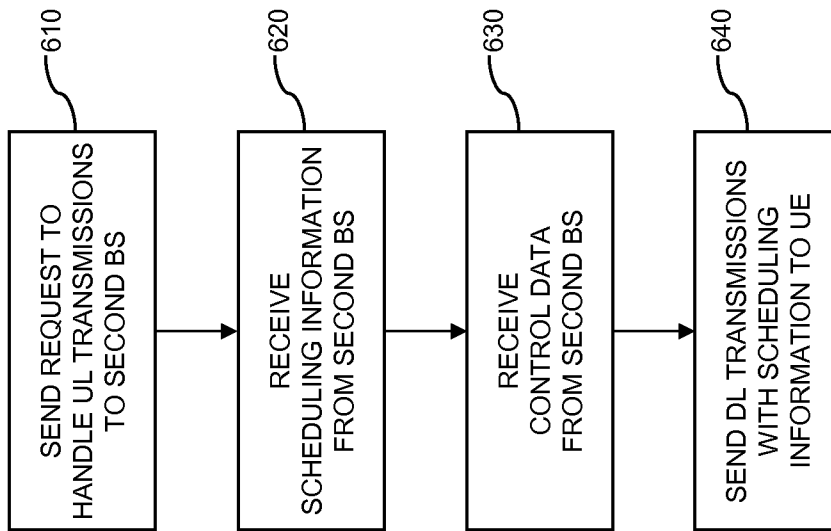

FIG. 6

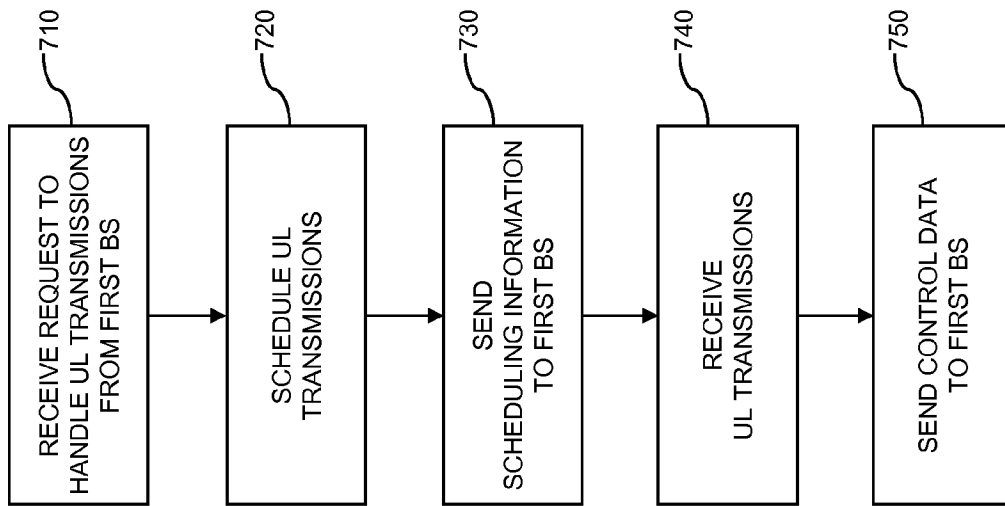

FIG. 7

**INTERNATIONAL SEARCH REPORT**

International application No PCT/EP2011/052679
---

**A. CLASSIFICATION OF SUBJECT MATTER**  
 INV. H04L5/00 H04W72/04  
 ADD.

According to International Patent Classification (IPC) or to both national classification and IPC

**B. FIELDS SEARCHED**

Minimum documentation searched (classification system followed by classification symbols)  
 H04L H04W

Documentation searched other than minimum documentation to the extent that such documents are included in the fields searched

Electronic data base consulted during the international search (name of data base and, where practical, search terms used)  
 EPO-Internal, WPI Data, INSPEC, COMPENDEX

**C. DOCUMENTS CONSIDERED TO BE RELEVANT**

Category*	Citation of document, with indication, where appropriate, of the relevant passages	Relevant to claim No.
X	WO 2010/087175 A1 (PANASONIC CORP [JP]; SUMASU ATSUSHI; OKASAKA SHOZO; TAKAOKA SHINSUKE;) 5 August 2010 (2010-08-05) the whole document -& EP 2 384 079 A1 (PANASONIC CORP [JP]) 2 November 2011 (2011-11-02) paragraphs [0013], [0014], [0019] - [0056], [0061] - [0068]	1-18
E	EP 2 291 053 A1 (FUJITSU LTD [JP]) 2 March 2011 (2011-03-02) paragraphs [0011] - [0012], [0016] - [0032]	1,6-18
	----- -/--	

Further documents are listed in the continuation of Box C.       See patent family annex.

\* Special categories of cited documents :

<p>"A" document defining the general state of the art which is not considered to be of particular relevance</p> <p>"E" earlier document but published on or after the international filing date</p> <p>"L" document which may throw doubts on priority claim(s) or which is cited to establish the publication date of another citation or other special reason (as specified)</p> <p>"O" document referring to an oral disclosure, use, exhibition or other means</p> <p>"P" document published prior to the international filing date but later than the priority date claimed</p>	<p>"T" later document published after the international filing date or priority date and not in conflict with the application but cited to understand the principle or theory underlying the invention</p> <p>"X" document of particular relevance; the claimed invention cannot be considered novel or cannot be considered to involve an inventive step when the document is taken alone</p> <p>"Y" document of particular relevance; the claimed invention cannot be considered to involve an inventive step when the document is combined with one or more other such documents, such combination being obvious to a person skilled in the art.</p> <p>"&amp;" document member of the same patent family</p>
--	--

Date of the actual completion of the international search  1 December 2011	Date of mailing of the international search report  07/12/2011
--	--

Name and mailing address of the ISA/ European Patent Office, P.B. 5818 Patentlaan 2 NL - 2280 HV Rijswijk Tel. (+31-70) 340-2040, Fax: (+31-70) 340-3016	Authorized officer  Barrientos Lezcano
--	--

## INTERNATIONAL SEARCH REPORT

International application No  
PCT/EP2011/052679

C(Continuation). DOCUMENTS CONSIDERED TO BE RELEVANT		
Category*	Citation of document, with indication, where appropriate, of the relevant passages	Relevant to claim No.
A	MORIMOTO A ET AL: "Investigation on Optimum Radio Link Connection Using Remote Radio Equipment in Heterogeneous Network for LTE-Advanced", 2009 IEEE 69TH VEHICULAR TECHNOLOGY CONFERENCE; APRIL 26-29, 2009, BARCELONA, SPAIN, IEEE, PISCATAWAY, NJ, USA, 26 April 2009 (2009-04-26), pages 1-5, XP031474564, ISBN: 978-1-4244-2517-4 section 2 figure 3  -----	1-18
A	ERICSSON ET AL: "Aspects on Distributed RRUs with Shared Cell-ID for Heterogeneous Deployments", 3GPP DRAFT; R1-110649 SHARED_CELL_ID, 3RD GENERATION PARTNERSHIP PROJECT (3GPP), MOBILE COMPETENCE CENTRE ; 650, ROUTE DES LUCIOLES ; F-06921 SOPHIA-ANTIPOLIS CEDEX ; FRANCE, vol. RAN WG1, no. Taipei, Taiwan; 20110221, 17 February 2011 (2011-02-17), XP050490740, [retrieved on 2011-02-17] section 2.4  -----	1-18
A	US 2010/105404 A1 (PALANKI RAVI [US] ET AL) 29 April 2010 (2010-04-29) paragraphs [0050] - [0088]  -----	1-18
A	WO 2010/083892 A1 (NOKIA SIEMENS NETWORKS OY [FI]; HAUSTEIN THOMAS [DE]; SCHULZ EGON [DE]) 29 July 2010 (2010-07-29) page 4, line 20 - page 5, line 3  -----	1-18
A	US 2010/008294 A1 (PALANKI RAVI [US] ET AL) 14 January 2010 (2010-01-14) paragraphs [0021] - [0025], [0030] - [0035], [0054]  -----	1-18
A	US 2010/238827 A1 (BORRAN JABER MOHAMMAD [US] ET AL) 23 September 2010 (2010-09-23) paragraphs [0021], [0022], [0028], [0056]  -----	1-18
A	NTT DOCOMO ET AL: "Inter-cell Radio Resource Management for Heterogeneous Network", 20080818, vol. 3GPP TSG RAN WG1 Meeting #54, no. R1-083019, 18 August 2008 (2008-08-18), pages 1-20, XP008136476, the whole document  -----	1-18

# INTERNATIONAL SEARCH REPORT

Information on patent family members

International application No PCT/EP2011/052679
---

Patent document cited in search report	Publication date	Patent family member(s)	Publication date
WO 2010087175 A1	05-08-2010	EP 2384079 A1 US 2011274073 A1 WO 2010087175 A1	02-11-2011 10-11-2011 05-08-2010
-----			
EP 2384079 A1	02-11-2011	EP 2384079 A1 US 2011274073 A1 WO 2010087175 A1	02-11-2011 10-11-2011 05-08-2010
-----			
EP 2291053 A1	02-03-2011	CN 102006153 A EP 2291053 A1 JP 2011055194 A KR 20110025067 A US 2011053585 A1	06-04-2011 02-03-2011 17-03-2011 09-03-2011 03-03-2011
-----			
US 2010105404 A1	29-04-2010	CN 102197698 A EP 2351450 A1 KR 20110074934 A TW 201019766 A US 2010105404 A1 WO 2010048502 A1	21-09-2011 03-08-2011 04-07-2011 16-05-2010 29-04-2010 29-04-2010
-----			
WO 2010083892 A1	29-07-2010	EP 2389747 A1 US 2011280163 A1 WO 2010083892 A1	30-11-2011 17-11-2011 29-07-2010
-----			
US 2010008294 A1	14-01-2010	CA 2728922 A1 CN 102090130 A EP 2327169 A2 KR 20110028653 A TW 201008334 A US 2010008294 A1 WO 2010006300 A2	14-01-2010 08-06-2011 01-06-2011 21-03-2011 16-02-2010 14-01-2010 14-01-2010
-----			
US 2010238827 A1	23-09-2010	US 2010238827 A1 WO 2010108152 A1	23-09-2010 23-09-2010
-----			