

E. F. MEYER.
 BROOM BRIDLE.
 APPLICATION FILED MAR. 18, 1911.

998,255.

Patented July 18, 1911.

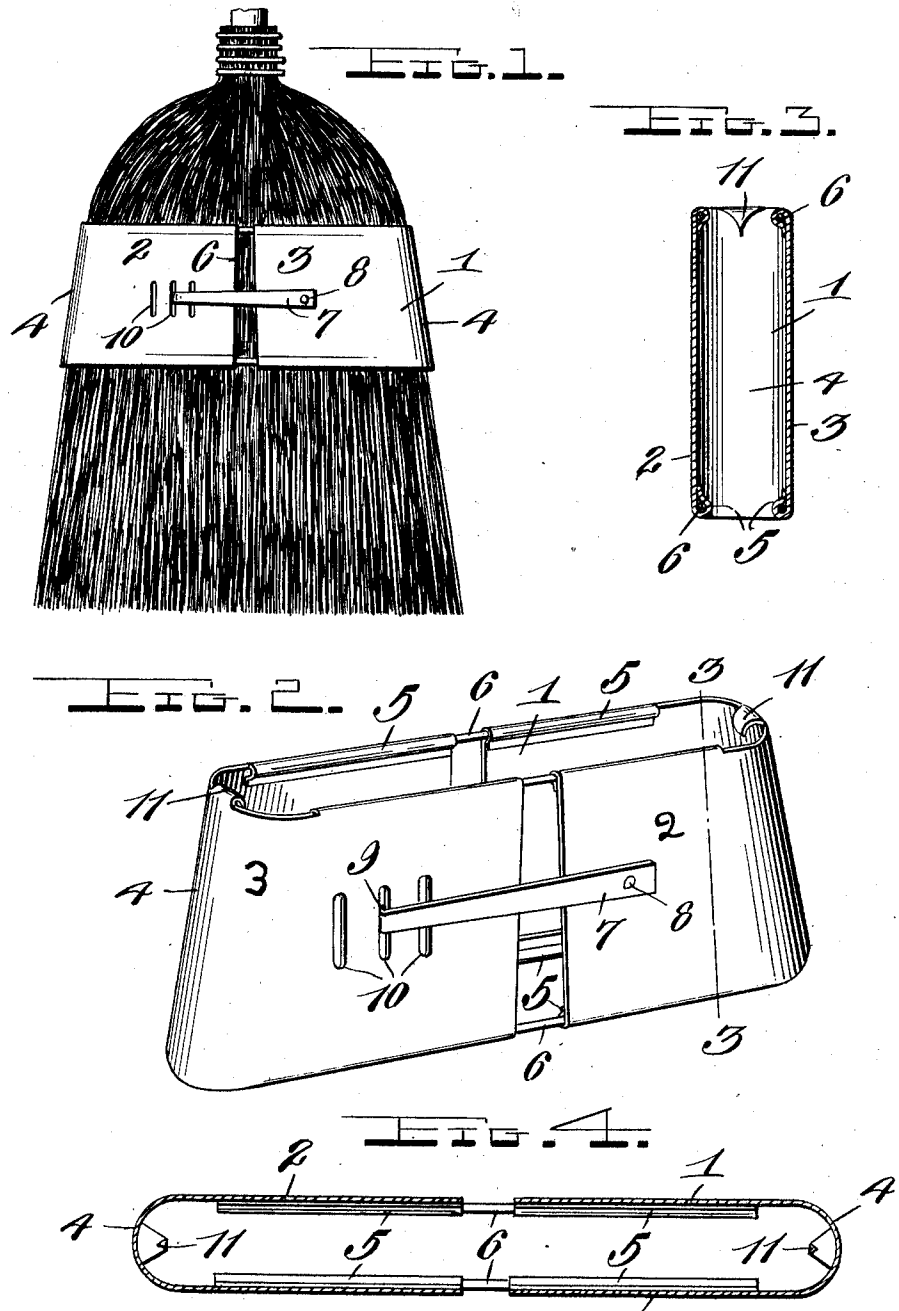

Inventor
E. F. Meyer;

Witnesses
Chas. L. Griebauer.
H. E. Coleman.

Wm. Watson E. Coleman.
 Attorney

UNITED STATES PATENT OFFICE.

EDWARD F. MEYER, OF BEAUFORT, MISSOURI.

BROOM-BRIDLE.

998,255.

Specification of Letters Patent. Patented July 18, 1911.

Application filed March 18, 1911. Serial No. 615,226.

To all whom it may concern:

Be it known that I, EDWARD F. MEYER, a citizen of the United States, residing at Beaufort, in the county of Franklin and State of Missouri, have invented certain new and useful Improvements in Broom-Bridles, of which the following is a specification, reference being had to the accompanying drawings.

My invention relates to improvements in broom bridles and has for its object to provide an improved bridle for brooms which will hold the straws close together at the lower or working end, which will make the broom wear more evenly and shall sweep more effectually.

Another object of my invention is to provide a broom bridle of this character which can be readily adjusted to brooms of various sizes.

A further object of my invention is to provide a broom bridle as mentioned which shall be of simple construction, of low cost to manufacture and one which may be readily applied or attached to a broom.

With the above and other objects in view the invention consists in the novel features of construction hereinafter described, pointed out in the claims and shown in the accompanying drawings in which—

Figure 1 is a side view of a broom bridle embodying my invention in its preferred form, showing the same applied to a broom; Fig. 2 is a perspective view with the bridle removed from the broom showing the opposite side of the bridle; Fig. 3 is a sectional view taken on the line 3—3 of Fig. 2; and Fig. 4 is a longitudinal sectional view.

Referring more particularly to the drawings 1 indicates the body of the bridle, which is made of sheet metal or other suitable material and made in two sections 2 and 3. Each section is made of a single piece of sheet metal bent upon itself and formed into such shape as to conform to the shape of a broom head, and having its outer end rounded to fit the outer edge of the broom head. The upper and lower edges respectively of the sections 2 and 3 are bent upon themselves to form the tubular beads 5. The sections 2 and 3 are adjustably connected by means of the rods 6 which are slidably mounted in the tubular beads 5. This is to allow the bridle to be adjustable to any size broom or brush and it is to be held in an

adjusted position by means of the fastening members 7 which are pivotally mounted on the side of the sections at 8 and their free ends bent upon themselves to form the hooks 9 which are adapted to engage in the transverse slots 10 formed in the sections 2 and 3. Each section is provided with an engaging hook 11 which is formed integral at the upper edge of each and approximately centrally arranged in its rounded outer end and is adapted to engage in the broom head when the bridle is applied thereto. This hook is to hold the bridle from slipping down too near the lower end of the broom or brush.

The bridle can be readily and easily applied to a broom or brush and held securely by means of the hooks 11 engaged in the broom head and the hook members 7 engaged in the slots 10.

It will be obvious that various changes in the details of construction and in the proportions may be resorted to for successfully carrying the invention into practice without sacrificing any of the novel features or departing from the scope thereof.

What I claim is:

1. In a device of the character described, the combination of a sectional broom bridle adapted to be applied to the head of a broom, tubular beads formed upon the lower and upper edges of the sections of said bridle, rods slidably mounted in said beads for permitting the adjustment of said sections to different size brooms and means for holding said sections in an adjusted position.

2. In a device of the character described, the combination of a sectional broom bridle, said bridle being adjustably connected by means of rods slidably mounted in tubular beads formed on the upper and lower edges of the sections, said sections being secured in an adjusted position by means of hook members pivotally mounted on each section, hooks formed on the free ends thereof, and each section being provided with transverse slots in which the hooks are engaged.

3. In a device of the character described, the combination of a sectional broom bridle adapted to be applied to the head of a broom, tubular beads formed upon the upper and lower edge of the sections of said bridle, rods slidably mounted in said beads for permitting the adjustment of said sec-

tions to different size brooms, an engaging
hook formed integral with each section at
the upper edge and approximately arranged
in its rounded outer end and adapted to en-
5 gage in the head of the broom when the
bridle is applied thereto, hook members piv-
otally mounted on each section, hooks
formed on the free ends thereof, and each

section being provided with transverse slots
in which the hooks are engaged. 10

In testimony whereof I hereunto affix my
signature in the presence of two witnesses.
EDWARD F. MEYER.

Witnesses:

W. H. LINSTROMBERG,
JNO. C. BIRKMANN.

Copies of this patent may be obtained for five cents each, by addressing the "Commissioner of Patents,
Washington, D. C."