

May 6, 1947.

C. F. OSGOOD

2,420,009

APPARATUS FOR TRANSFERRING MATERIAL IN MINES

Filed April 7, 1944

6 Sheets-Sheet 1

Fig. 1.

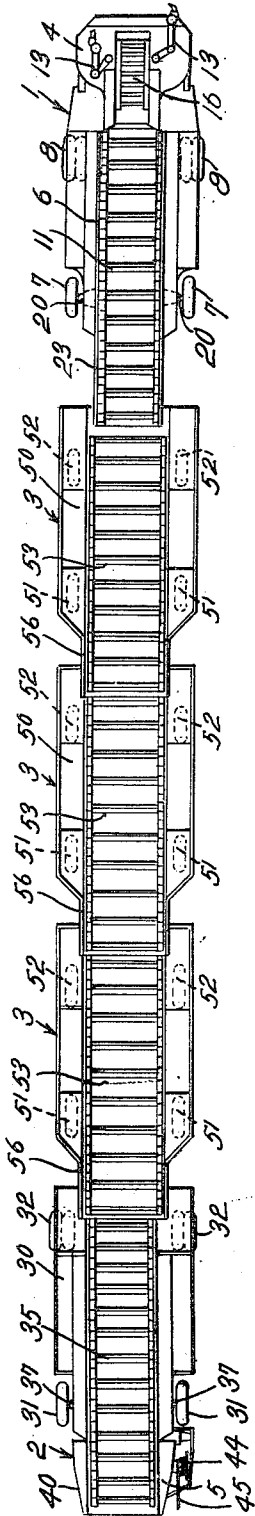

Fig. 6.

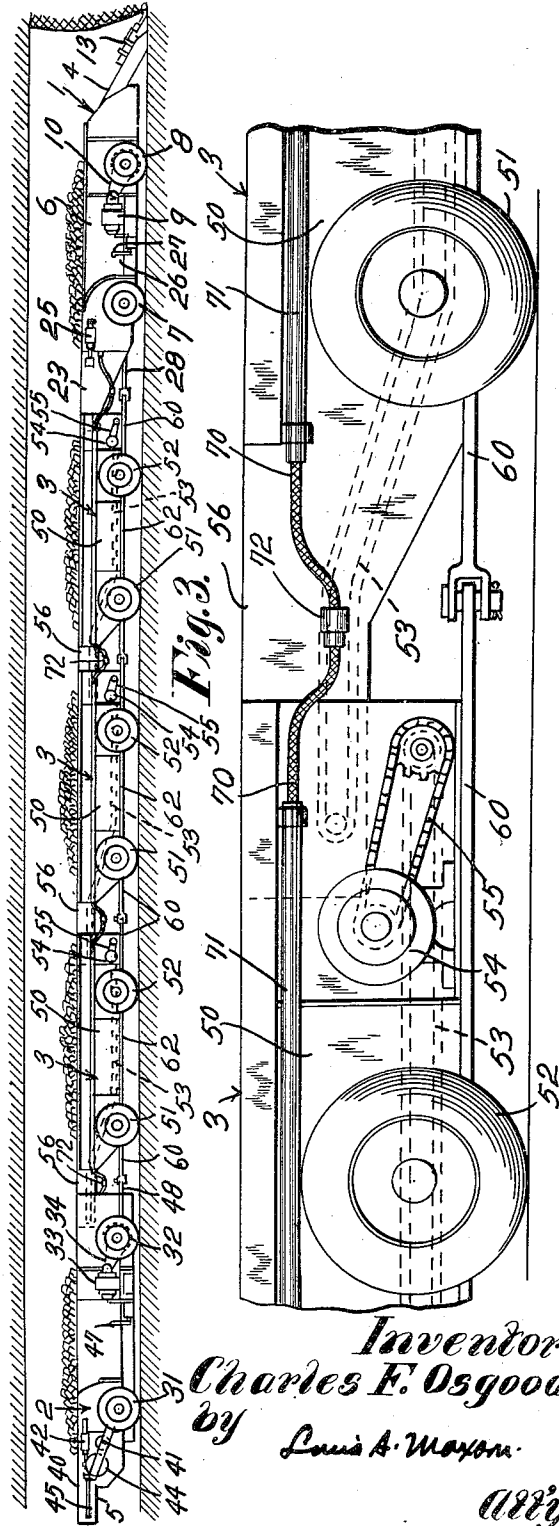
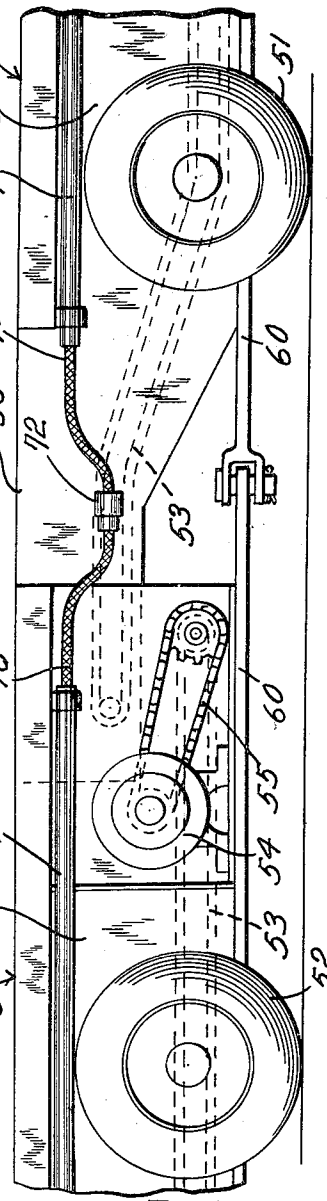

Fig. 3.



Inventor:  
Charles F. Osgood.

by Louis A. Maxon.

Att'y.

May 6, 1947.

C. F. OSGOOD

2,420,009

APPARATUS FOR TRANSFERRING MATERIAL IN MINES

Filed April 7, 1944

6 Sheets-Sheet 2

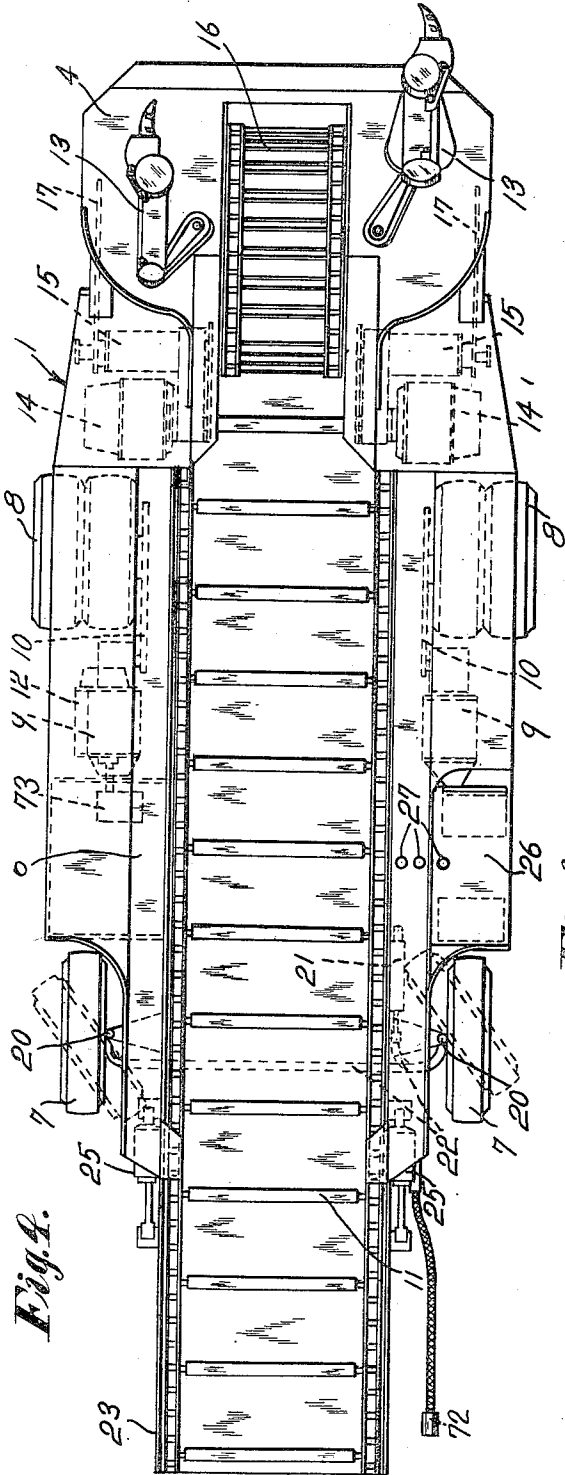

Fig. 1.

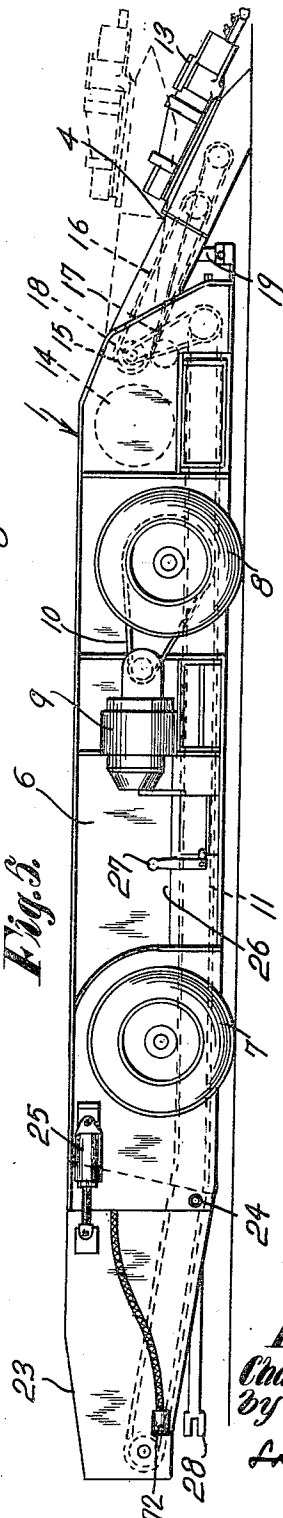

Fig. 2.

Inventor:  
Charles F. Osgood  
by  
Louis B. Maxson.  
Atty.

May 6, 1947.

C. F. OSGOOD

2,420,009

APPARATUS FOR TRANSFERRING MATERIAL IN MINES

Filed April 7, 1944

6 Sheets-Sheet 3

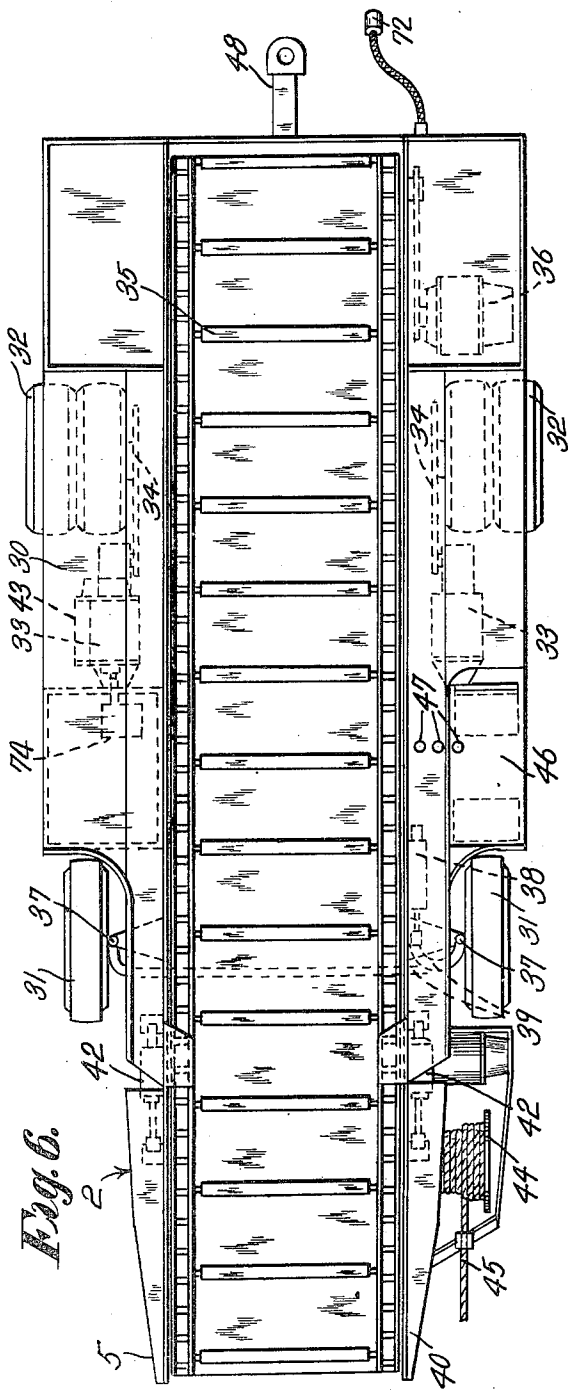

Fig. 6.

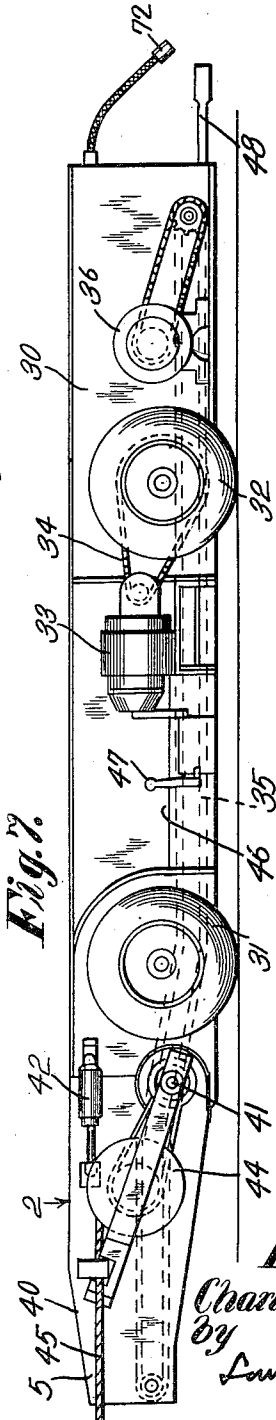

Fig. 7.

Inventor:  
Charles F. Osgood  
By  
Louis A. Mastrom.  
Att'y.

May 6, 1947.

C. F. OSGOOD

2,420,009

APPARATUS FOR TRANSFERRING MATERIAL IN MINES

Filed April 7, 1944

6 Sheets-Sheet 4

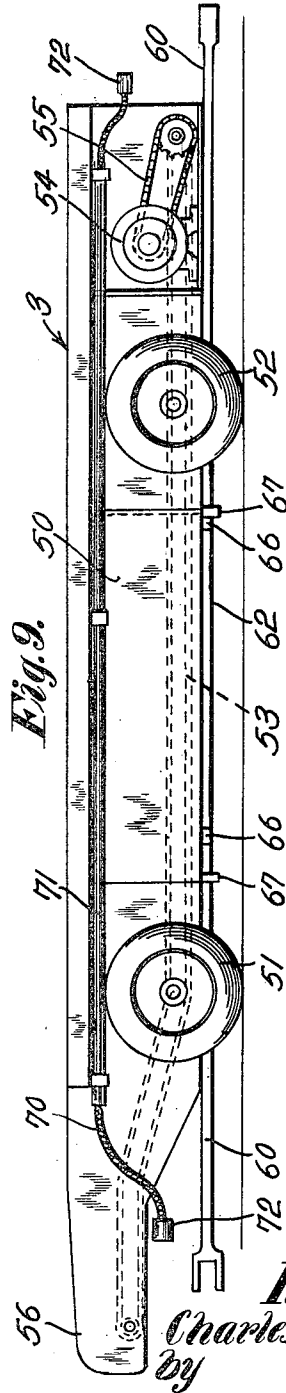
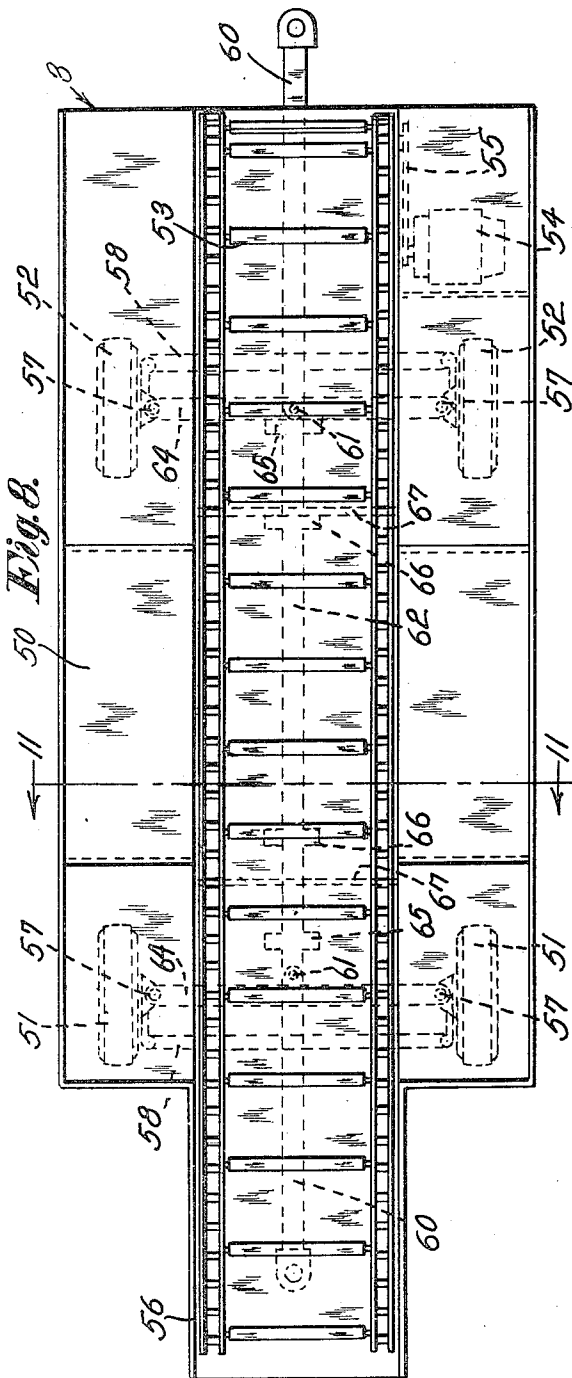

Inventor:  
Charles F. Osgood.  
By  
Louis A. Weston.  
Atty.

May 6, 1947.

C. F. OSGOOD

2,420,009

APPARATUS FOR TRANSFERRING MATERIAL IN MINES

Filed April 7, 1944

6 Sheets-Sheet 5

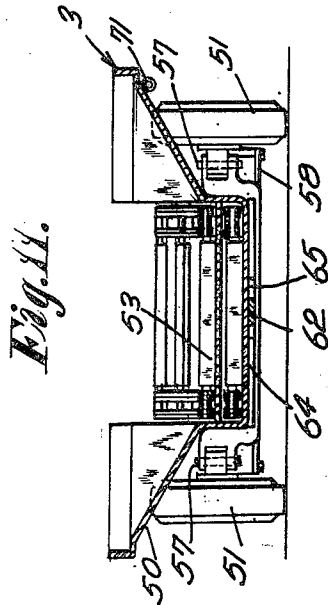
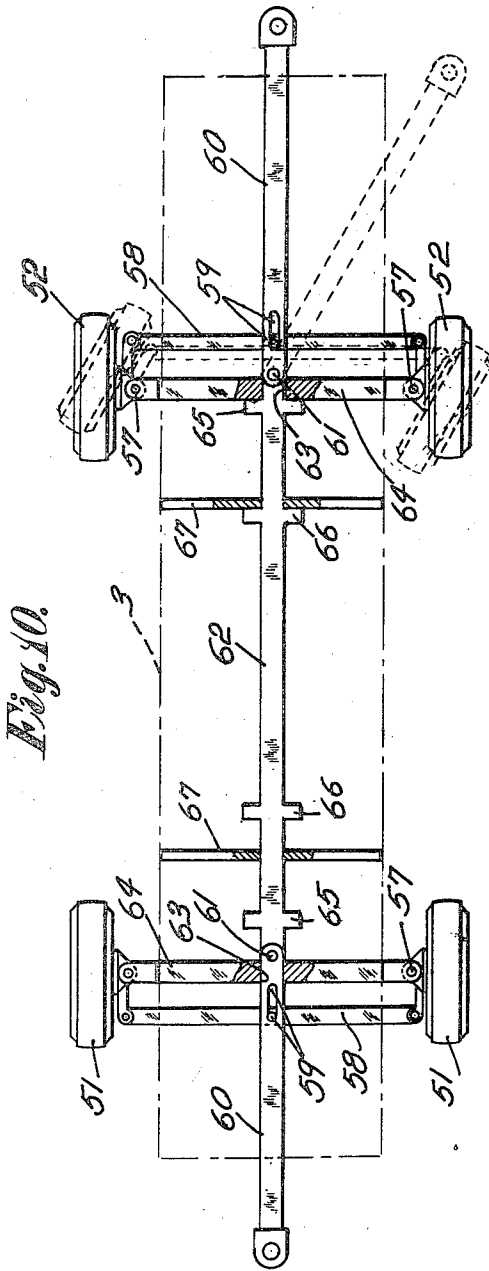

*Inventor:*  
*Charles F. Osgood.*

*By* *Louis A. Maxson.*

*Atty.*



# UNITED STATES PATENT OFFICE

2,420,009

## APPARATUS FOR TRANSFERRING MATERIAL IN MINES

Charles F. Osgood, Claremont, N. H., assignor to  
Joy Manufacturing Company, a corporation of  
Pennsylvania

Application April 7, 1944, Serial No. 530,009

16 Claims. (Cl. 214-83)

1

This invention relates to an apparatus for transferring material and more particularly to an improved apparatus for loading, hauling and unloading loose material in an underground mine.

Heretofore, in trackless coal mines, it has been common practice to employ self-propelled cars commonly known as "shuttle cars" to effect transfer of coal or other material from the working face to the main entry of the mine. Such "shuttle cars" are separately operated and as individual units must have their own power operated propelling and steering means, and are accordingly more costly than similar equipment which omits power propulsion and steering. In known instances, in trackless coal mines, a train of cars has been moved about the mine by a tractor unit, but such train must be completely turned around after each transfer cycle since there is a power operated propelling and steering unit at but one end of the train, preventing reversal of the train. Considerable time and space are necessary to permit turning of a relatively long train of cars in an underground mine. Such train of cars must also be loaded from the side by a mobile loading machine, and considerable time must be consumed in the maneuvering of the train and the loading machine to effect complete loading of all of the cars of the train. By the provision of a train of rubber-tired wheeled cars wherein the end car units of the train are power operated and the intermediate car units are trailer cars, it is possible to move relatively large quantities of material about the mine without the necessity of turning the train around after each transfer cycle. Since the intermediate trailer cars have no power operated propelling and steering means, their individual cost is considerably less than that of a conventional "shuttle car" so that the initial investment in equipment is considerably lowered over convention "shuttle car" equipment having similar capacity. Also by the provision of a bottom conveyor for each car unit of the train, the train may be completely loaded from one end, thereby eliminating the necessity of "spotting" the cars and the time consuming maneuvering of the loading machine and cars during the loading operation. Also, by the provision of such bottom conveyors for each car unit, the entire train may be unloaded from one end of the train.

An object of the present invention is to provide an improved apparatus for transferring loose material in mines. Another object is to provide an improved apparatus for loading, hauling and unloading loose material in underground

2

mines. Still another object is to provide an improved material transfer apparatus especially designed for use in trackless coal mines. A further object is to provide an articulated train of material transport cars mounted on rubber-tired wheels adapted to run directly over the floor of a mine for hauling loose material from one location to another. Still another object is to provide a train of articulated material transport cars having conveying means for moving material along the entire length of the train and provided with a power operated propelling unit at each end of the train. A still further object is to provide an improved material transfer apparatus embodying a train of articulated material transport cars and having a power operated propelling and steering unit at each end of the train, whereby the latter may be operated in either of opposite directions. A further object is to provide an improved material transfer apparatus embodying a train of articulated material transport cars and means for loading material into the cars at one end of the train and for unloading the material from the cars at the opposite end of the train. Another object is to provide in an apparatus of the above character improved means for moving the material to be transported lengthwise of the train, whereby all of the cars of the train may be filled with material and whereby all of the cars of the train may be unloaded from an end of the train. These and other objects and advantages of the invention will, however, hereinafter more fully appear.

In the accompanying drawings there is shown for purposes of illustration one form which the invention may assume in practice.

In these drawings:

Fig. 1 is a plan view of the improved apparatus for loading, hauling and unloading loose material in mines.

Fig. 2 is a side elevational view of the apparatus shown in Fig. 1.

Fig. 3 is an enlarged fragmentary view in side elevation showing a pair of adjacent car units coupled together.

Fig. 4 is an enlarged plan view of the loading car unit, shown in Figs. 1 and 2.

Fig. 5 is a side elevational view of the loading car unit shown in Fig. 4.

Fig. 6 is an enlarged plan view of the unloading car unit shown in Figs. 1 and 2.

Fig. 7 is a side elevational view of the unloading car unit shown in Fig. 6.

Fig. 8 is an enlarged plan view of one of the

3

intermediate trailer car units shown in Figs. 1 and 2.

Fig. 9 is a side elevational view of the trailer car unit shown in Fig. 8.

Fig. 10 is a bottom view, shown somewhat diagrammatically, illustrating the sliding drawbar and swiveled wheel mounting structure of the trailer cars.

Fig. 11 is a cross sectional view taken substantially on line 11--11 of Fig. 8, showing the trailer car structure.

Fig. 12 is a diagrammatical view illustrating the method of operation of the improved material transfer apparatus in an underground coal mine.

In this illustrative embodiment of the invention, there is shown a material transfer apparatus embodying a train of articulated material transport receptacles and having a power operated propelling and steering unit at each end of the train. The material transport receptacles are herein in the form of mine cars loosely coupled together and mounted on rubber-tired wheels adapted to run directly over the floor of a mine.

In this novel construction, the train includes a power operated loading unit, generally designated 1, at one end of the train and a power operated unloading unit, generally designated 2, at the other end of the train, and there is a series of intermediate trailer car units, generally designated 3. The trailer car units are coupled to the end power units and are coupled together. The loading and unloading units 1 and 2 each have propelling and steering means, and the loading unit 1 has a loading head 4, and the unloading unit 2 has an unloading tail 5. The units 1, 2 and 3 have relatively large capacity material receiving receptacles or bodies for receiving the material to be transported or hauled about the mine. Each of the units 1, 2 and 3 has a bottom conveyor whereby the cars may be loaded and unloaded, as will later be explained, and the power operated propelling and steering units at the ends of the train are each provided with a station for an operator, whereby the train may be controlled during its operation, and the conveyors of the several units may be started and stopped as desired, under operator control from either end of the train.

The train, due to its rubber-tired wheel mountings, may run about the mine without the aid of a guiding trackway, and, by the provision of a power operated propelling and steering unit at each end of the train, the train may be operated in either of opposite directions as desired. The loading head 4 may load loose material from the mine floor into the receptacle or body of the loading unit, and the conveyors of the several units may be operated so that the cars of the entire train may be completely loaded with material from one end of the train. And the conveyors may be operated so that the entire train of cars may be unloaded from the opposite end of the train. Thus the train may be shuttled back and forth between the coal face and the main entry of a mine without the necessity of turning the train around after each transfer cycle as has heretofore been necessary in trackless coal mines.

Now referring to the specific structure of the apparatus and more particularly to the specific structure of the loading unit 1, shown in Figs. 4 and 5, it will be noted that a relatively large capacity receptacle or car body 6 is mounted on rubber-tired wheels 7 and 8 adapted to run directly over the floor of the mine. The wheels 7 are steering wheels while the wheels 8 are traction

4

wheels, and the latter may be driven by motors 9, 9 through conventional chain and sprocket transmission connections 10. Extending longitudinally of the loading unit along the bottom of the car body is an endless bottom conveyor 11. A motor 12 drives the liquid pumping means, as later explained. The loading head 4 has conventional gathering devices 13, 13 herein in the form of gathering arms respectively driven by motors 14, 14 through conventional transmission connections 15, and the conveyor 11 is driven through a portion of these connections. The gathering devices operate to move loose material such as loose coal from the mine floor onto an elevating conveyor 16 driven through suitable connections 17 from the motors 14. The motors 9, 12 and 14 are preferably electric motors, although any suitable type of motor may be employed. The loading head 4 is pivotally mounted at 18 to swing in a vertical direction, and hydraulic jacks 19 are provided to effect swinging of the loading head from its lowered loading position to its elevated transport position and vice versa. If desired, the loading head 4 may be omitted from the end car unit 1, and the cars may be loaded by a separate loading apparatus in the manner well known to those skilled in the art. The steering wheels 7 are swiveled at 20 at the sides of the car body and may be operated to effect steering by a hydraulic steering cylinder 21 through conventional link and lever steering connections 22. The discharge or tail end 23 of the conveyor 11 is vertically tiltable about a horizontal pivot 24 by means of hydraulic jacks 25. Thus the discharge height of the conveyor may be varied as desired. At one side of the car body is a recess or platform 26 to provide a station for the operator of the loading unit 1, and usual controls 27 are conveniently located near the operator's station so that the various power operated devices of the loading unit 1 may be readily operated and controlled. The loading unit has, at its end opposite from the loading head, a conventional drawbar coupling 28.

Now referring to the unloading or discharge unit 2 at the opposite end of the train, it will be observed that, in Figs. 6 and 7, there is shown a material receiving receptacle or car body 30 of relatively large capacity mounted on rubber-tired wheels 31 and 32 adapted to run directly over the mine floor. The wheels 31 are steering wheels and the wheels 32 are traction wheels, the latter being driven by motors 33, 33 through conventional chain and sprocket transmission connections 34. Extending longitudinally along the bottom of the car body is an endless bottom conveyor 35 driven by a motor 36. The steering wheels 31 are swiveled at 37 and may be operated to effect steering by a hydraulic steering cylinder 38 through link and lever steering connections 39. The tail end 40 of the discharge conveyor is vertically tiltable about a pivot 41 and is adjustable by hydraulic jacks 42. A motor 43 drives the liquid pumping means. The motors 33, 36 and 43 are likewise preferably electric motors. Mounted at one side of the car body is an automatic cable reel 44 for an electric conductor cable 45. As in the loading unit 1 above described, the unloading or discharge unit 2 has a recess or platform 46 to provide a station for the operator, and controls 47 for the various power operated devices of the unloading unit are conveniently located near the operator's station. The unloading or discharge unit has, at its end opposite from its discharge end, a conventional drawbar coupling 48.

The intermediate trailer units 3, as shown in Figs. 8 and 9, include large capacity material receiving receptacles or car bodies 50 mounted on rubber-tired wheels 51 and 52 adapted to run directly over the mine floor. The trailer units 3 have no power operated propelling and steering means and are moved about the mine by means of the power units 1 and 2 at the opposite ends of the train. Each of the bodies of the trailer units 3 has extending longitudinally thereof along its bottom an endless conveyor 53 driven by a motor 54 through conventional chain and sprocket connections 55. Each conveyor 53 has an elevated discharge end 56 which may be vertically adjustable similarly to the conveyors of the end car units 1 and 2, if desired. In Fig. 11, a trailer car 3 is shown in cross section to illustrate the shape of the car body and the arrangement of the bottom conveyor 53, and the bodies of the other cars and the other conveyors may be similarly shaped and arranged. The wheels 51 and 52 of each trailer car 3, as shown in Fig. 10, are swiveled at 57 to facilitate steering of the trailer car as it is hauled back and forth about the mine. The swiveled wheels of each pair 51 and 52 are connected by cross links 58, and each cross link 58 is connected by a pin and slot 59 to a swinging drawbar or steering arm 60. The drawbars 60 are pivoted at 61 to the opposite ends of a sliding drawbar 62 mounted for limited longitudinal movement in guide slots 63 formed in cross axles 64 secured to the bottom of the car body. The coupling bars of the adjacent car units are attachable to the swinging drawbars 60 in a conventional manner thereby to provide some flexibility of movement in horizontal and vertical directions. To limit the longitudinal movement of the sliding drawbar 62, the latter is provided with spaced lugs 65 and 66 located at the opposite sides of rigid cross members 67 secured to the car body. The lugs 65, 66 are so arranged that, when the drawbar 62 is slid longitudinally in one direction, one set of lugs engage the cross members 67, and, when slid in the opposite direction, the other set of lugs engage the transverse axles 64. When the drawbar 62 is slid to the right, as viewed in Fig. 10, the left-hand pivoted drawbar 60 moves within the slot 63 so that it is locked against pivotal movement. At that time the right-hand drawbar 60 is free to swing about its pivot 61 to effect swiveling of the wheels 52. When the drawbar 62 is slid to the left in Fig. 10, the right-hand drawbar 60 is locked and the left-hand drawbar 60 is free to swing to effect steering. By this arrangement, it is apparent that when it is desired to move the trailer car units 3 in either direction, a pulling force is exerted on the drawbars 62 to slide the latter along the car bottoms until they are stopped by the lugs. Thus the leading wheels of the trailer car units are always free to swing, while the trailing wheels thereof are locked against swinging movement. By the provision of such swivel mountings for the trailer car wheels steering of the trailer cars, as the train moves back and forth during its operation, is facilitated. This steering feature will permit the trailer cars to be readily moved through the curved passageways in the mine and will materially facilitate moving of the train back and forth between the coal face and the main entry of the mine. Other suitable manners of locking the trailing wheels against swinging movement and for freeing the leading wheels may be employed. The loose couplings between the conventional drawbars permit flexibility in horizontal and vertical planes there-

by to facilitate movement of the train through the sharply curved passageways and over the uneven floor of a mine.

When the train of articulated cars roll along the mine floor from the main entry of the mine into a mine passageway which has no trolley wire, the conductor cable 45 may be connected to the trolley wire in the entry, and as the train moves into the passageway, the cable reel 44 automatically pays out the conductor cable in a well known manner. When the train moves in the opposite direction toward the main entry, the cable reel automatically winds in the conductor cable. The articulated car units 1, 2 and 3 of the train may be provided with conventional electrical controllers so that the various electric motors of the several car units may be operated and controlled as desired. The controls for the motors of the conveyors of the intermediate trailer units 3 may be located near the operators' stations on the end power units 1 and 2 of the train so that the intermediate conveyors 53 may be operated and controlled from the operators' stations on the end car units. Such remote controls for electric motors are well known. Power may be conducted from the cable reel 44 through conductor cables 70 extending through conduits 71 along one side of each of the trailer car units 3, and suitable detachable flame-proof couplings 72 (Fig. 3) may be provided between adjacent car units.

Each of the end car units 1 and 2 of the train may respectively be provided with pumps 73 and 74 respectively driven by the electric motors 12 and 43 for supplying liquid under pressure to the various hydraulically operated devices of the train. Obviously, the wheels of the several car units may be provided with conventional brakes which likewise may be hydraulically operated in a well known manner.

The general mode of operation of the improved material transfer apparatus above described is as follows. The train of articulated cars may be steered and propelled as it moves about the mine by either or both of the end power units 1 and 2, and, by the provision of the loose couplings between the series of car units and the swiveled wheel mountings, the train may readily negotiate the curved passageways of an underground mine, in the manner shown diagrammatically in Fig. 12. In Fig. 2 the train is shown in loading position with the end loading unit 1 located near the working face, and the loading head 4 may be operated to gather the loose material or loose coal from the mine floor, to elevate the loose coal and to discharge the coal so elevated into the car body. The conveyors 11, 35 and 53 of the series of car units 1, 2 and 3 may be concurrently or independently operated to move the material longitudinally of the train in such manner as to fill completely the cars of the entire train. When the train is loaded to capacity, the loading head 4 may be raised into its transport position. The train may then be propelled by the traction wheels 32 of the unloading unit 2 to the left, as viewed in Fig. 2, and the leading wheels of the intermediate trailer cars are automatically freed by drawbar pull to enable swiveling thereof while the trailing wheels are automatically locked against swiveling movement. The train of cars may be steered and propelled by the leading end power unit or by both end power units. When the main entry is reached and it is desired to unload the material carried by the train, the conveyors 11, 35 and 53 of all of the car units may be concurrently operated to effect unloading of the material complete-

ly from the train at one end of the train. Thus it will be evident that the train may be completely loaded with material from one end, and the material may be completely unloaded from the train from its opposite end. After unloading, the train may be propelled to the right, as viewed in Fig. 1, by the leading power unit or by both end power units thus obviating the necessity of completely turning the entire train around upon the completion of each material transfer cycle.

As a result of this invention an improved apparatus for transferring material in mines is provided, whereby the material transfer cycle is greatly expedited over previous known methods. By the provision of the train of articulated material transport cars embodying a power operated propelling and steering unit at each end of the train, large quantities of material may be transferred in an underground mine with comparative rapidity. The steering and coupling arrangement between the series of cars enables the train easily to negotiate the curved and relatively restricted passageways of an underground mine. Moreover, by the provision of a power operated propelling and steering unit at each end of the train, the train may be rapidly shuttled back and forth between the points of loading and unloading without the necessity of turning the train around at the end of each transfer cycle. Other uses and advantages of the invention will be obvious to those skilled in the art.

While there is in this application specifically described one form which the invention may assume in practice it will be understood that this form is disclosed for purposes of illustration and that the invention may be modified and embodied in various other forms without departing from its spirit or the scope of the appended claims.

What I claim as new and desire to secure by Letters Patent is:

1. A self-contained apparatus for gathering, hauling, and unloading loose material in mines comprising a laterally and vertically flexible train including a series of articulated wheel supported material transport cars flexibly coupled to turn laterally and vertically in either direction and adapted to travel over the uneven floor and through the curved passageways of a mine without the aid of a guiding trackway, said cars each having a material receiving compartment and steering wheels, a material gathering and loading device carried by the end car at one end of the train for loading material onto the train, mechanical power operated means associated with each car and discharging into the compartment of the next adjacent car for progressively moving the material so loaded from car to car lengthwise of the train to fill all of the compartments irrespective of the laterally and vertically flexed position of the train, said compartments having overlapping sides and bottom portions at the discharge ends of said material moving means and said moving means being so arranged in said compartments and so constructed that the material may be moved from car to car without appreciable spillage even when the train is laterally and vertically flexed as aforesaid, and a material discharge device carried by the end car at the opposite end of the train for discharging the material from the train, said mechanical moving means operating to move the material progressively from car to car during such discharge.

2. A self-contained apparatus for gathering, hauling and unloading loose material in mines

comprising a laterally and vertically flexible train including a series of articulated wheel supported material transport cars flexibly coupled to turn laterally and vertically in either direction and adapted to travel over the uneven floor and through the curved passageways of a mine without the aid of a guiding trackway, said cars each having a material receiving compartment and steering wheels, a material gathering and loading device carried by the end car at one end of the train for gathering material and for loading material so gathered onto the train, mechanical power operated, independently controllable conveying means extending along the bottom of the compartment of each car and discharging into the compartment of the next adjacent car for progressively moving the material so loaded from car to car lengthwise of the train so that the compartments of all of the cars may be filled with material irrespective of the laterally and vertically flexed position of the train, said compartments having overlapping sides and bottom portions at the discharge ends of said material conveying means and said conveying means being so arranged in said compartments and so constructed that the material may be moved from car to car without appreciable spillage even when the train is laterally and vertically flexed as aforesaid, and a material discharge device carried by the end car at the opposite end of the train for discharging the material from the train, said conveying means being controllable to move the material progressively from car to car during such discharge.

3. A self-contained apparatus for loading, hauling and unloading loose material in mines comprising a laterally and vertically flexible train including a series of flexibly coupled material transport cars having supporting wheels adapted to run directly along the mine floor without the aid of the guiding trackway and each having steering means so that the cars may turn laterally in either direction with respect to one another as the train moves through the curved passageways of a mine, and each car having a material receiving compartment, a material gathering and loading device carried by the end car at one end of the train for gathering material from the mine floor and for moving the material onto the train, mechanical power operated means extending along the bottom of the compartment of each car and discharging into the next adjacent compartment for moving the material discharged from said loading device progressively from car to car lengthwise of the train to fill the compartments of the several cars with material irrespective of the laterally and vertically flexed position of the train, said compartments having overlapping sides and bottom portions at the discharge ends of said material moving means and said moving means being so arranged in said compartments and so constructed that the material may be moved from car to car without appreciable spillage even when the train is laterally and vertically flexed as aforesaid, and a material discharge device carried by the end car at the opposite end of the train for discharging the material from the train, said conveying means operating to move the material progressively from car to car during such discharge.

4. A self-contained, reversible apparatus for hauling loose material in mines comprising a laterally and vertically flexible train including a series of articulated wheel supported material transport cars flexibly coupled together and each

having a material receiving compartment, each of said cars having steering wheels and the intermediate cars having reversible, bodily longitudinally shiftable control mechanism for the steering wheels thereof for rendering the wheels at one end or at the other of each intermediate car effective to steer depending upon the direction of movement of the train, the end cars having prime movers and embodying power operated propelling and steering means for driving certain of the wheels of the end cars and for operating the steering wheels of said end cars whereby the train may be propelled and steered as it moves through the curved passageways of a mine, said end cars constituting the propelling means for the intermediate cars regardless of the direction in which the train is propelled and controlling the actuation of said shiftable control mechanism whereby the steering means of the end cars control the steering means of the intermediate cars during either direction of movement thereof.

5. A self-contained, reversible apparatus for transferring material in mines comprising a laterally and vertically flexible train of articulated wheel supported material transport cars flexibly coupled together and adapted to travel over the uneven floor and through the sharply curved passageways of a mine without the aid of a guiding trackway, each of said cars having steering wheels and a material receiving body, the intermediate cars having reversible, bodily longitudinally shiftable control mechanism for the steering wheels thereof for rendering the wheels at one end or at the other of each intermediate car effective to steer depending upon the direction of movement of the train, and the end cars at the opposite ends of the train having propelling and steering means for propelling and steering the train regardless of the direction in which the train is propelled, said propelling means of said end cars effecting bodily shifting of said reversible control mechanism to control the steering wheels of the intermediate cars during either direction of movement of the train.

6. A self-contained apparatus for transferring material in mines comprising a laterally and vertically flexible train of articulated wheel supported material transport cars flexibly coupled together and adapted to travel over the uneven floor and through the sharply curved passageways of a mine without the aid of a guiding trackway, each of said cars having steering wheels and a material receiving body of large capacity, power operated mechanical conveying means extending along the bottom of each of said car bodies for moving the material from car to car lengthwise of the train irrespective of the flexed relation of the train, said conveying means being so arranged with respect to the cars that the tops of the portions of said conveying means which extend along the bottoms of the car bodies are disposed a substantial distance below the tops of said wheels in close adjacency to the wheel axes and to the bottoms of said car bodies, and said car bodies having overlapping sides and bottom portions at the discharge ends of said conveying means and said conveying means being so arranged in said car bodies and so constructed that the material may be moved from car to car even when the cars are laterally or vertically flexed out of a straight line without appreciable spillage of the material.

7. A self-contained, reversible apparatus for transferring material in mines comprising a lat-

erally and vertically flexible train of articulated wheel supported material transport cars flexibly coupled together and adapted to travel over the uneven floor and through the sharply curved passageways of a mine without the aid of a guiding trackway, each of said cars having steering wheels and a material receiving body and the intermediate cars having reversible, bodily longitudinally shiftable control mechanism for the steering wheels thereof for rendering the wheels at one end or at the other of each intermediate car effective to steer depending upon the direction of movement of the train, the end cars at the opposite ends of the train having steering means for steering the train and said end cars being power operated and constituting propelling means for the intermediate trailer cars for shutting the train rapidly back and forth between spaced locations in a mine without turning around of the train, said propelling means for said end cars effecting bodily shifting of said reversible control mechanism for controlling the steering wheels of said intermediate cars as the train is moved in one direction or the other.

8. A self-contained, reversible apparatus for hauling loose material in mines comprising a laterally and vertically flexible train including a series of articulated wheel supported material transport cars flexibly coupled together and each having a material receiving compartment, each of said cars having steering means and the intermediate cars each having front and rear steering wheels mounted to swing horizontally and reversely actuatable drawbar means for alternately locking the swingable steering wheels at one end of each of the intermediate cars depending on the direction in which the train is pulled, the end cars having prime movers and embodying power operated propelling and steering means for driving certain of the wheels of the end cars and for operating the steering means of said end cars whereby the train may be propelled and steered as it moves through the curved passageways of a mine, said end cars constituting the propelling means for the intermediate cars regardless of the direction in which the train is propelled and coupled to said reversible drawbar means whereby the steering wheels of the intermediate cars are automatically controlled in accordance with the direction in which the train is propelled.

9. A self-contained, reversible apparatus for transferring material in mines comprising a laterally and vertically flexible train of articulated wheel supported material transport cars flexibly coupled together and adapted to travel over the uneven floor and through the sharply curved passageways of a mine without the aid of a guiding trackway, each of the cars having steering wheels and a material receiving body, and the intermediate cars having reversely actuatable bodily longitudinally shiftable drawbar means for the steering wheels thereof for controlling steering thereby, and the end cars at the opposite ends of the train having power operated propelling and steering means for propelling and steering the train regardless of the direction in which the train is propelled, said end cars being coupled to said shiftable drawbar means and said propelling means of said end cars effecting shifting of said drawbar means to make operative the steering wheels at one end or at the other of each of the intermediate cars depending upon the direction of movement of the train.

10. A material transferring apparatus for

11

mines, comprising a laterally and vertically flexible train including a series of articulated wheel supported, rubber-tired material transport cars flexibly coupled together to turn laterally in either direction and to move up and down relative to each other thereby to facilitate movement of the train through the sharply curved passageways and over an uneven floor of a mine without the aid of a guiding trackway, each car having a material receiving compartment and steering wheels and each compartment having a conveyor extending along the bottom thereof, said cars having overlapping sides and bottom portions at the discharge ends of the conveyors and said conveyors being so arranged in said compartments that material may be moved progressively from car to car lengthwise of the train without appreciable spillage even when the train is laterally and vertically flexed as aforesaid, the end cars of the train having power operated wheel driving means and power operated steering means and constituting power units for pulling the train in one direction or the other, and the intermediate cars being trailer cars and being propelled by said end cars and the steering wheels of said intermediate cars being controlled by the steering means of said end cars, and each of said cars having power operated driving means for the conveyors thereof whereby the conveyors may be selectively operated to move the material received in the end car at one end of the train progressively from car to car to fill the compartments of all of the cars, and whereby the conveyors may be concurrently operated to move the material progressively from car to car continuously along the length of the train to discharge the material from the end car at the opposite end of the train.

11. A self-contained, reversible apparatus for hauling loose material in underground mines, comprising a laterally and vertically flexible train including a series of articulated wheel-supported material transport cars flexibly coupled together and each having a material receiving compartment, each of said cars having steering means and the intermediate cars being trailer cars and each having front and rear steering wheels mounted to swing horizontally, locking means for holding said wheels against swinging movement, and reversely actuatable, longitudinally shiftable control means for actuating said locking means alternately to lock the swingable steering wheels at one end of each of the intermediate cars depending upon the direction in which the train is pulled, the end cars having prime movers and embodying power operated propelling and steering means for driving certain of the wheels of the end cars and for operating the steering means of the end cars whereby the train may be propelled and steered as it moves through the curved passageways of a mine, said end cars constituting the propelling means for the intermediate cars regardless of the direction in which the train is propelled and connected to said shiftable control means whereby the steering wheels of the intermediate cars are automatically controlled in accordance with the direction in which the train is propelled.

12. A self-contained, reversible apparatus for hauling loose material in underground mines, comprising a laterally flexible train, including a series of articulated wheel-supported material transport cars flexibly coupled together and each having a material receiving compartment, each of said cars having steering means and the inter-

12

mediate cars being trailer cars and each having front and rear steering wheels mounted to swing horizontally, locking means for holding said wheels against swinging movement and reversely actuatable, longitudinally shiftable control means for said locking means for alternately locking the swingable steering wheels at one end of each of the intermediate cars depending upon the direction in which the train is pulled, the end cars having prime movers and embodying power operated propelling and steering means for driving certain of the wheels of the end cars and for operating the steering means of the end cars whereby the train may be propelled and steered as it moves through the curved passageways of a mine, and said end cars constituting the propelling means for the intermediate cars regardless of the direction in which the train is propelled and connected to said shiftable lock control means whereby the steering means of the intermediate cars are automatically controlled in accordance with the direction in which the train is propelled.

13. A self-contained, reversible apparatus for hauling loose material in underground mines, comprising a laterally and vertically flexible train including a series of articulated wheel-supported material transport cars flexibly coupled together and each having a material receiving compartment, each of said cars having steering means and the intermediate cars being trailer cars and each having front and rear steering wheels mounted to swing horizontally, and reversely actuatable control means for alternately holding the steering wheels at one end of each intermediate car against swinging movement depending upon the direction in which the train is pulled, the end cars having prime movers and power operated propelling and steering means for driving certain of the wheels of the end cars and for operating the steering means of the end cars whereby the train may be propelled and steered as it moves through the curved passageways of a mine, said end cars constituting propelling means for the intermediate cars regardless of the direction in which the train is propelled and operatively connected to said control means whereby different steering wheels of the intermediate cars may be rendered effective depending upon the direction in which the train is propelled.

14. A self-contained apparatus for hauling loose material in mines comprising a laterally and vertically flexible train including a series of articulated wheel supported material transport cars flexibly coupled to turn laterally and vertically in either direction and adapted to travel over the uneven floor and through the curved passageways of a mine without the aid of a guiding trackway, said cars each having a material receiving compartment and steering wheels, mechanical power operated means associated with each car and discharging into the compartment of the next adjacent car for progressively moving the material from car to car lengthwise of the train to fill all of the compartments irrespective of the laterally and vertically flexed position of the train, said compartments having overlapping sides and bottom portions at the discharge ends of said material moving means and said moving means being so arranged in said compartments and so constructed that the material may be moved from car to car without appreciable spillage even when the train is laterally and vertically flexed as aforesaid, and a material discharge device carried by an end car of the

13

train for discharging the material from the train, said mechanical moving means operating to move the material progressively from car to car during such discharge.

15. A self-contained apparatus for hauling loose material in mines comprising a laterally and vertically flexible train including a series of articulated wheel supported material transport cars flexibly coupled to turn laterally and vertically in either direction and adapted to travel over the uneven floor and through the curved passageways of a mine without the aid of a guiding trackway, said cars each having a material receiving compartment and steering wheels, mechanical power operated, independently controllable conveying means extending along the bottom of the compartment of each car and discharging into the compartment of the next adjacent car for progressively moving the material from car to car lengthwise of the train so that the compartments of all of the cars may be filled with material irrespective of the laterally and vertically flexed position of the train, said compartments having overlapping sides and bottom portions at the discharge ends of said material conveying means and said conveying means being so arranged in said compartments and so constructed that the material may be moved from car to car without appreciable spillage even when the train is laterally and vertically flexed as aforesaid, and a material discharge device carried by an end car of the train for discharging the material from the train, said conveying means being controllable to move the material progressively from car to car during such discharge.

16. A self-contained apparatus for hauling loose material in mines comprising a laterally and vertically flexible train including a series of flexibly coupled material transport cars having supporting wheels adapted to run directly along the mine floor without the aid of the guiding trackway and each having steering means so that the cars may turn laterally in either direction with respect to one another as the train moves through the curved passageways of a mine, and each car having a material receiving compartment, mechanical power operated means ex-

14

tending along the bottom of the compartment of each car and discharging into the next adjacent compartment for moving the material progressively from car to car lengthwise of the train to fill the compartments of the several cars with material irrespective of the laterally and vertically flexed position of the train, said compartments having overlapping sides and bottom portions at the discharge ends of said material moving means and said moving means being so arranged in said compartments and so constructed that the material may be moved from car to car without appreciable spillage even when the train is laterally and vertically flexed as aforesaid, and a material discharge device carried by an end car of the train for discharging the material from the train, said conveying means operating to move the material progressively from car to car during such discharge.

CHARLES F. OSGOOD.

#### REFERENCES CITED

The following references are of record in the file of this patent:

#### UNITED STATES PATENTS

Number	Name	Date
2,108,536	Joy -----	Feb. 15, 1938
1,683,287	Coburn et al. -----	Sept. 4, 1928
2,282,704	Butters -----	May 12, 1942
1,602,779	Prockter -----	Oct. 12, 1926
1,218,908	Shutt -----	Mar. 13, 1917
775,765	Renard -----	Nov. 22, 1904
992,682	Muller -----	May 16, 1911
2,225,185	Sloane -----	Dec. 17, 1940
1,442,342	Hines -----	Jan. 16, 1923
1,512,521	Cadman -----	Oct. 21, 1924
1,505,476	London -----	Aug. 19, 1924
776,994	Brennan -----	Dec. 6, 1904

#### FOREIGN PATENTS

Number	Country	Date
435,193	French -----	Oct. 13, 1911
8,364	British -----	Oct. 7, 1910
8,022	Austrian -----	June 25, 1902
664	British -----	Mar. 5, 1870