

(12) **United States Patent**
Xue et al.

(10) **Patent No.:** **US 12,096,432 B2**
(45) **Date of Patent:** **Sep. 17, 2024**

(54) **DYNAMIC GROUP COMMON PHYSICAL CONTROL CHANNEL**

(71) Applicant: **QUALCOMM Incorporated**, San Diego, CA (US)
(72) Inventors: **Yisheng Xue**, San Diego, CA (US);
Jing Sun, San Diego, CA (US);
Chih-Hao Liu, San Diego, CA (US);
Rajat Prakash, San Diego, CA (US);
Xiaoxia Zhang, San Diego, CA (US)
(73) Assignee: **QUALCOMM Incorporated**, San Diego, CA (US)

(*) Notice: Subject to any disclaimer, the term of this patent is extended or adjusted under 35 U.S.C. 154(b) by 326 days.

(21) Appl. No.: **17/473,674**
(22) Filed: **Sep. 13, 2021**

(65) **Prior Publication Data**
US 2022/0086819 A1 Mar. 17, 2022

Related U.S. Application Data
(60) Provisional application No. 63/080,004, filed on Sep. 17, 2020.
(51) **Int. Cl.**
H04W 72/20 (2023.01)
H04W 28/06 (2009.01)
(52) **U.S. Cl.**
CPC **H04W 72/20** (2023.01); **H04W 28/06** (2013.01)
(58) **Field of Classification Search**
CPC H04W 72/20; H04W 28/06
See application file for complete search history.

(56) **References Cited**

U.S. PATENT DOCUMENTS

2011/0125749 A1* 5/2011 Wood H04L 43/028
707/E17.046
2012/0099556 A1* 4/2012 Kim H04W 72/121
370/329
2013/0046979 A1* 2/2013 Karp G06Q 20/4093
713/168
2015/0350087 A1* 12/2015 Hong H04L 67/1001
370/230
2016/0174136 A1* 6/2016 Patil H04W 8/14
370/312
2017/0286464 A1* 10/2017 Puntti G06F 16/951

(Continued)

FOREIGN PATENT DOCUMENTS

WO WO2019080555 A1 * 2/2019

OTHER PUBLICATIONS

International Search Report and Written Opinion—PCT/US2021/050239—ISA/EPO—Jan. 4, 2022 (208095WO).

Primary Examiner — Christopher M Crutchfield
Assistant Examiner — Tito Q Pham
(74) *Attorney, Agent, or Firm* — Holland & Hart LLP

(57) **ABSTRACT**

Methods, systems, and devices for wireless communications are described. The method includes receiving a configuration message indicating a group common control resource allocated to a set of UEs that includes the UE, identifying a hashing function assigned to the UE for detecting control messaging communicated via the group common control resource that is addressed to the UE, receiving, via the group common control resource, a control message indicating addressing data and a bitmap, and processing the addressing data using the hashing function and the bitmap to determine applicability of the control message to the UE.

30 Claims, 19 Drawing Sheets

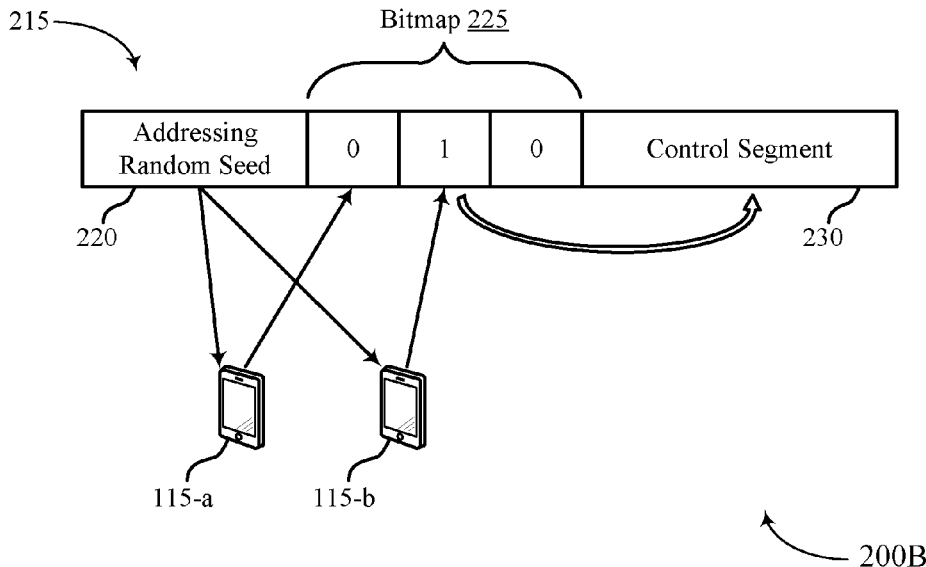

(56)

References Cited

U.S. PATENT DOCUMENTS

2019/0069231 A1* 2/2019 Kneckt H04W 52/0235
2019/0104510 A1* 4/2019 Lee H04W 72/12
2019/0313383 A1* 10/2019 Xiong H04W 16/14
2019/0349180 A1* 11/2019 Lu H04L 27/2607
2020/0037396 A1* 1/2020 Islam H04W 52/0229
2020/0112484 A1* 4/2020 Sun H04L 5/003
2020/0127778 A1* 4/2020 Zhuang H04W 28/0205
2020/0275443 A1* 8/2020 Zhang H04L 27/26025
2020/0288482 A1 9/2020 Yi et al.
2020/0404617 A1* 12/2020 Murray H04W 68/02
2021/0297483 A1* 9/2021 Ottaviano H05B 47/19
2021/0345302 A1* 11/2021 Wong H04W 72/20
2022/0052790 A1* 2/2022 Lei H04L 1/1607
2022/0150922 A1* 5/2022 Wu H04W 72/0446
2022/0159643 A1* 5/2022 Lin H04W 72/20
2022/0201748 A1* 6/2022 Harada H04L 5/001

* cited by examiner

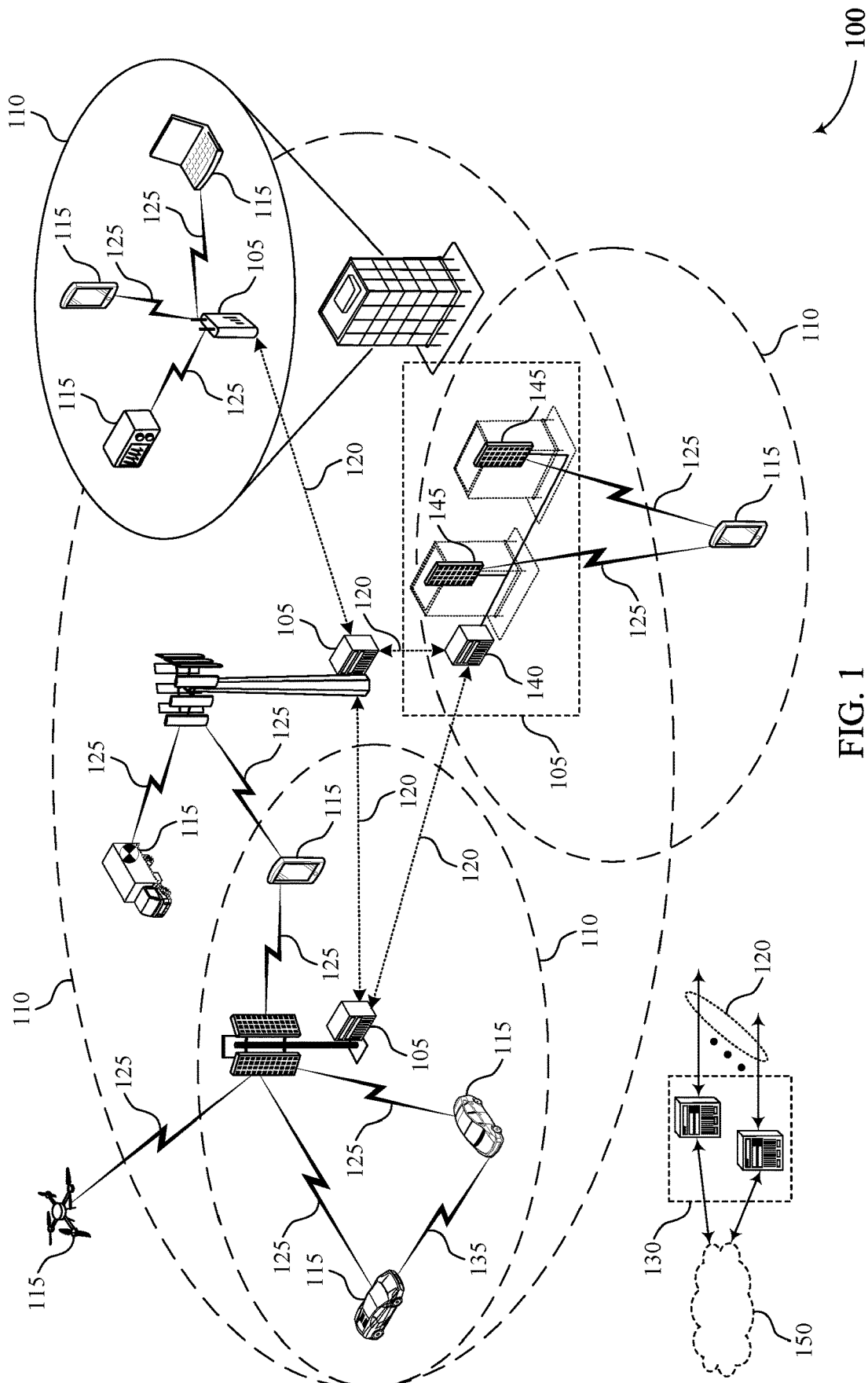

FIG. 1

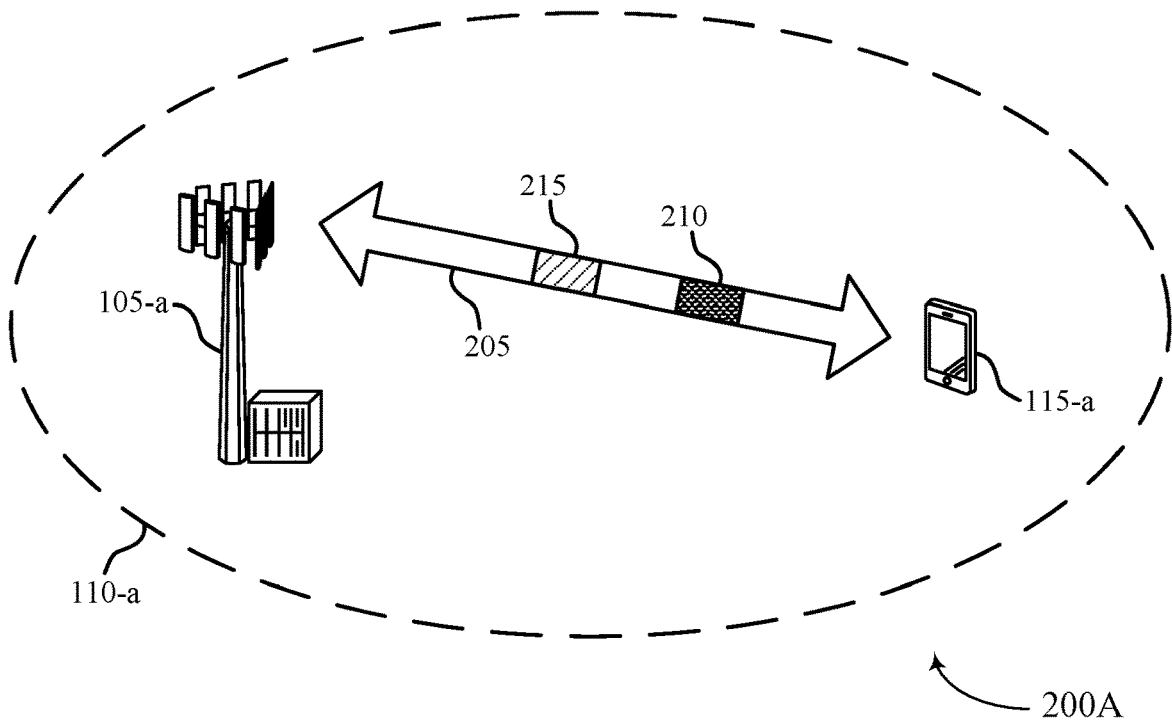

FIG. 2A

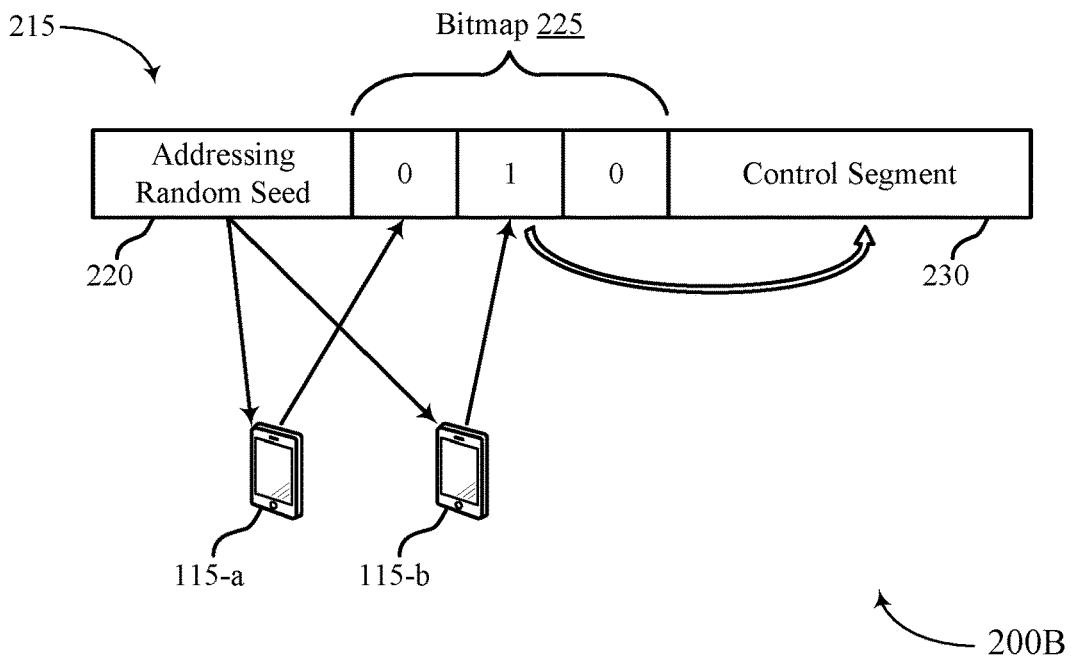
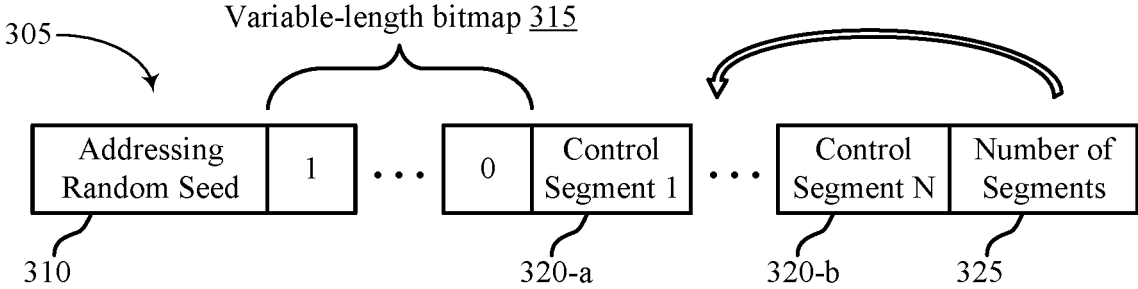

FIG. 2B



300

FIG. 3

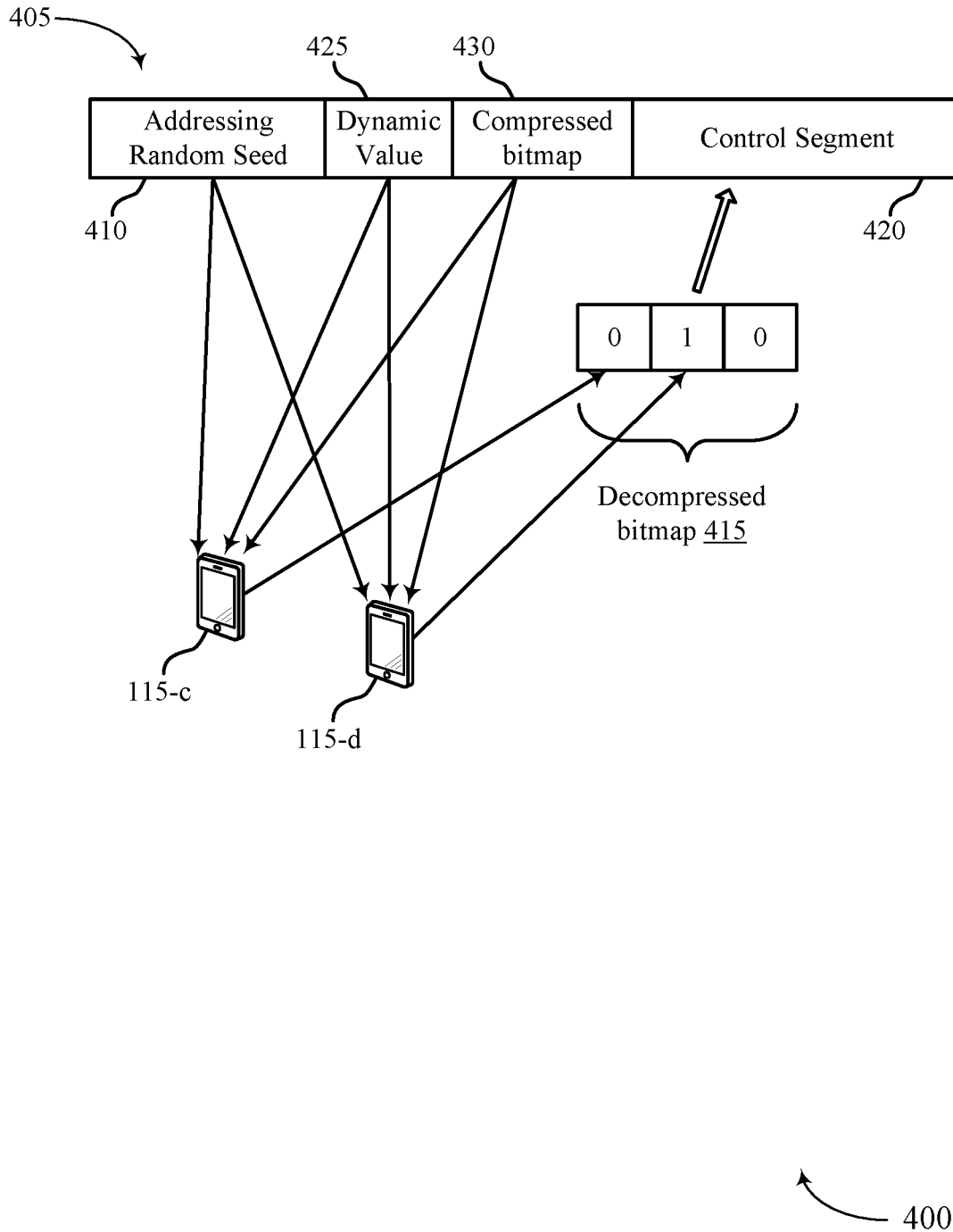

FIG. 4

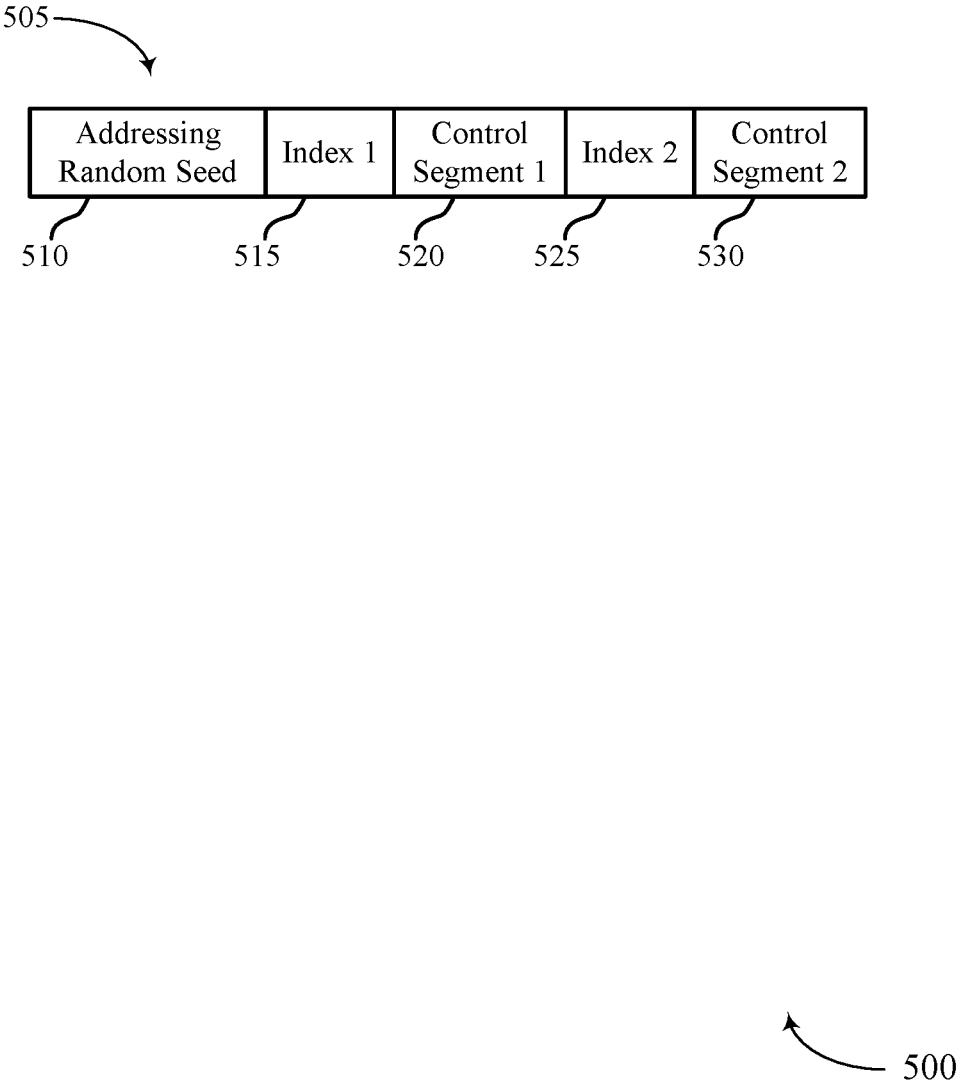
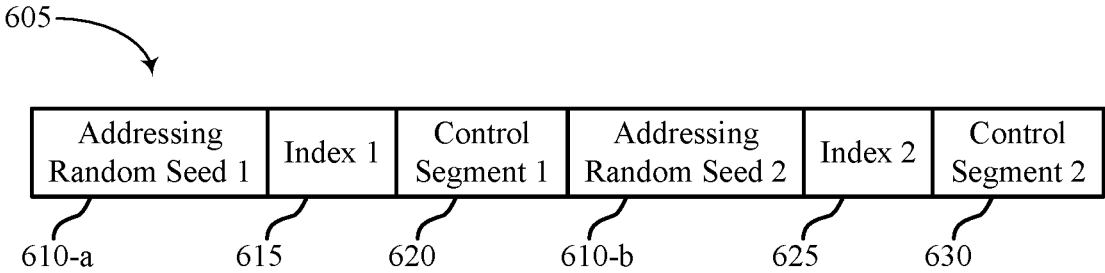
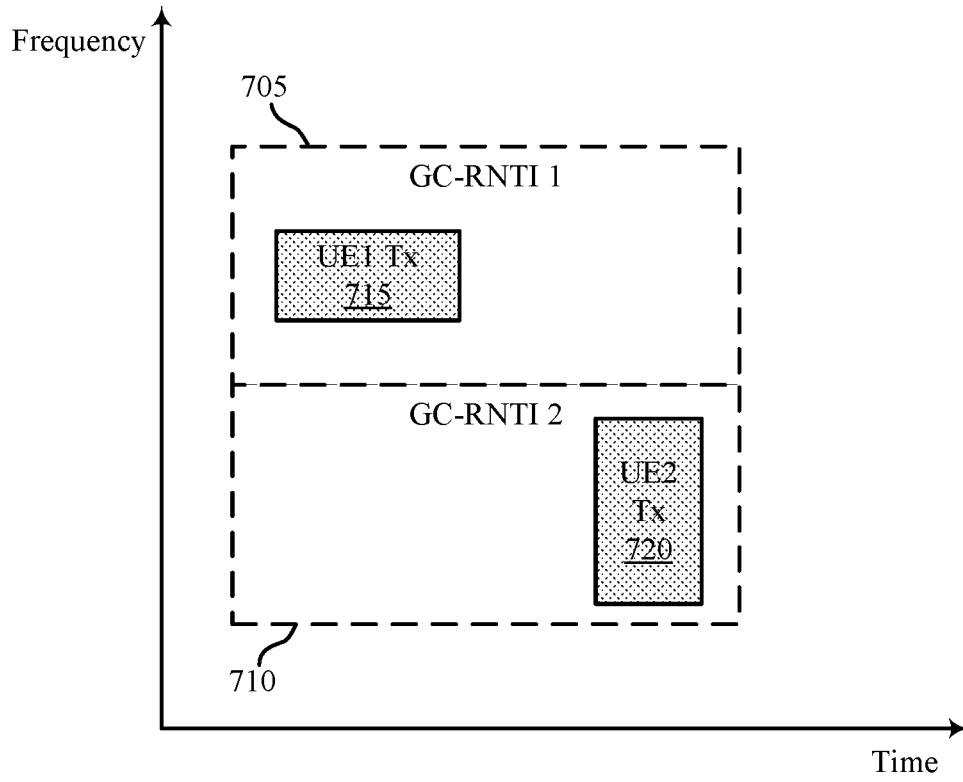

FIG. 5



600

FIG. 6



700

FIG. 7

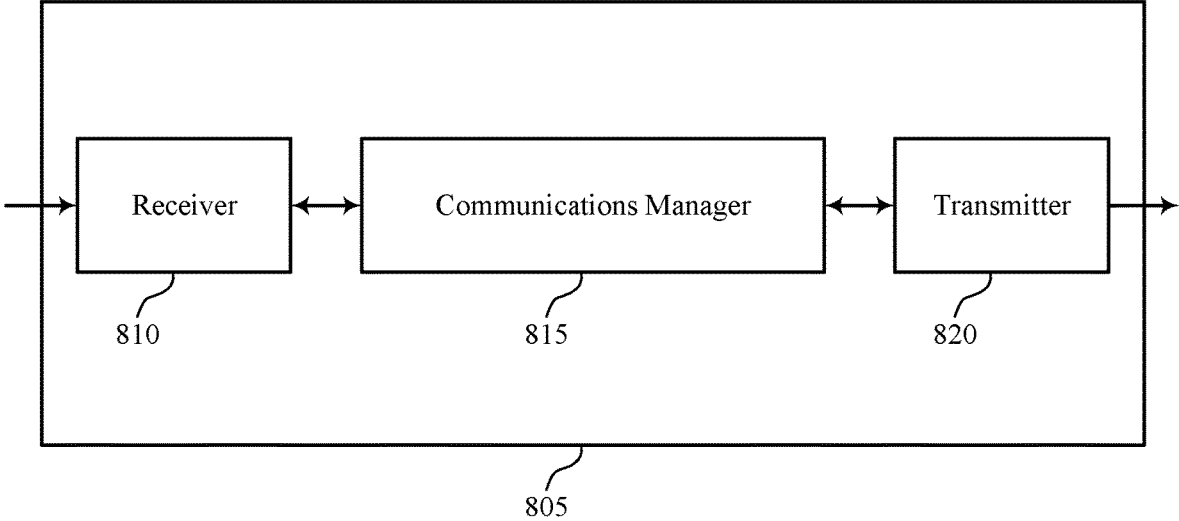

FIG. 8

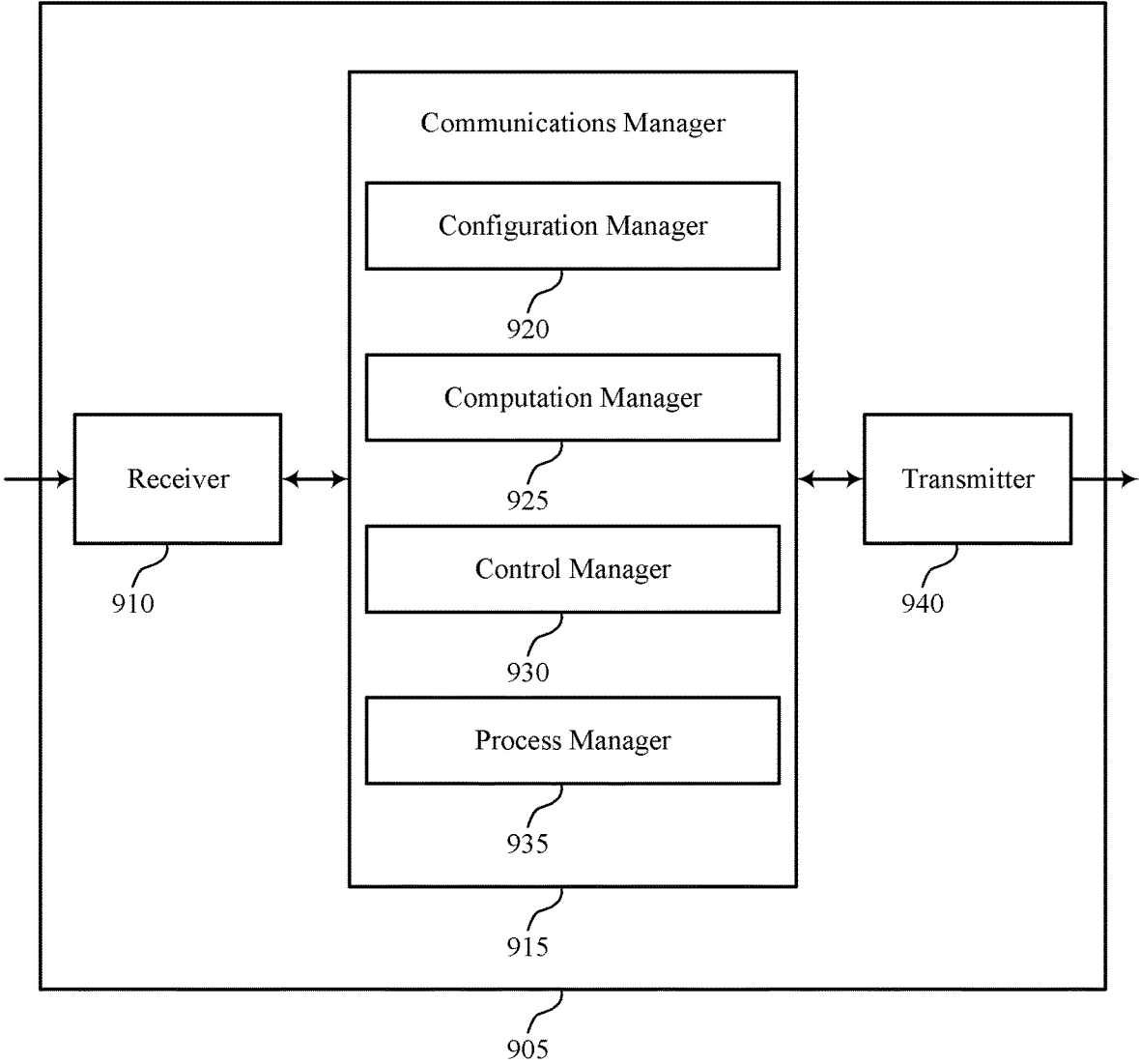
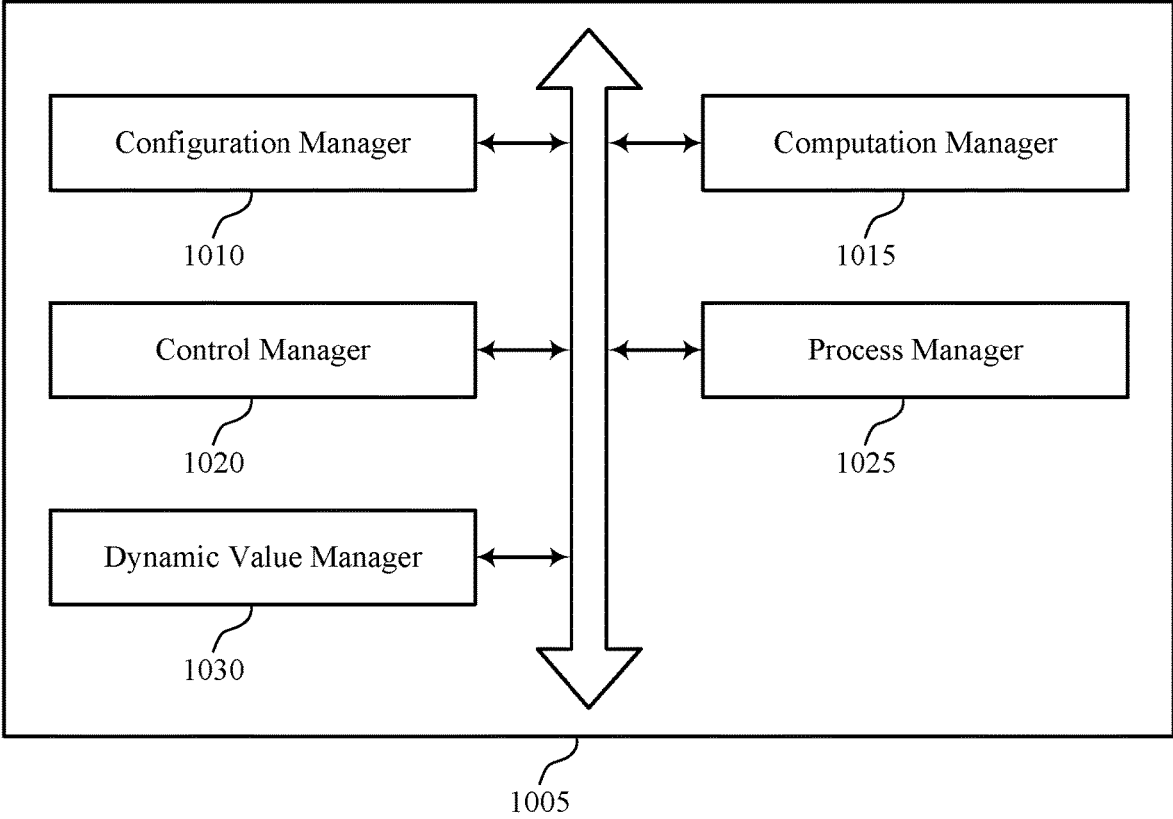

FIG. 9



1000

FIG. 10

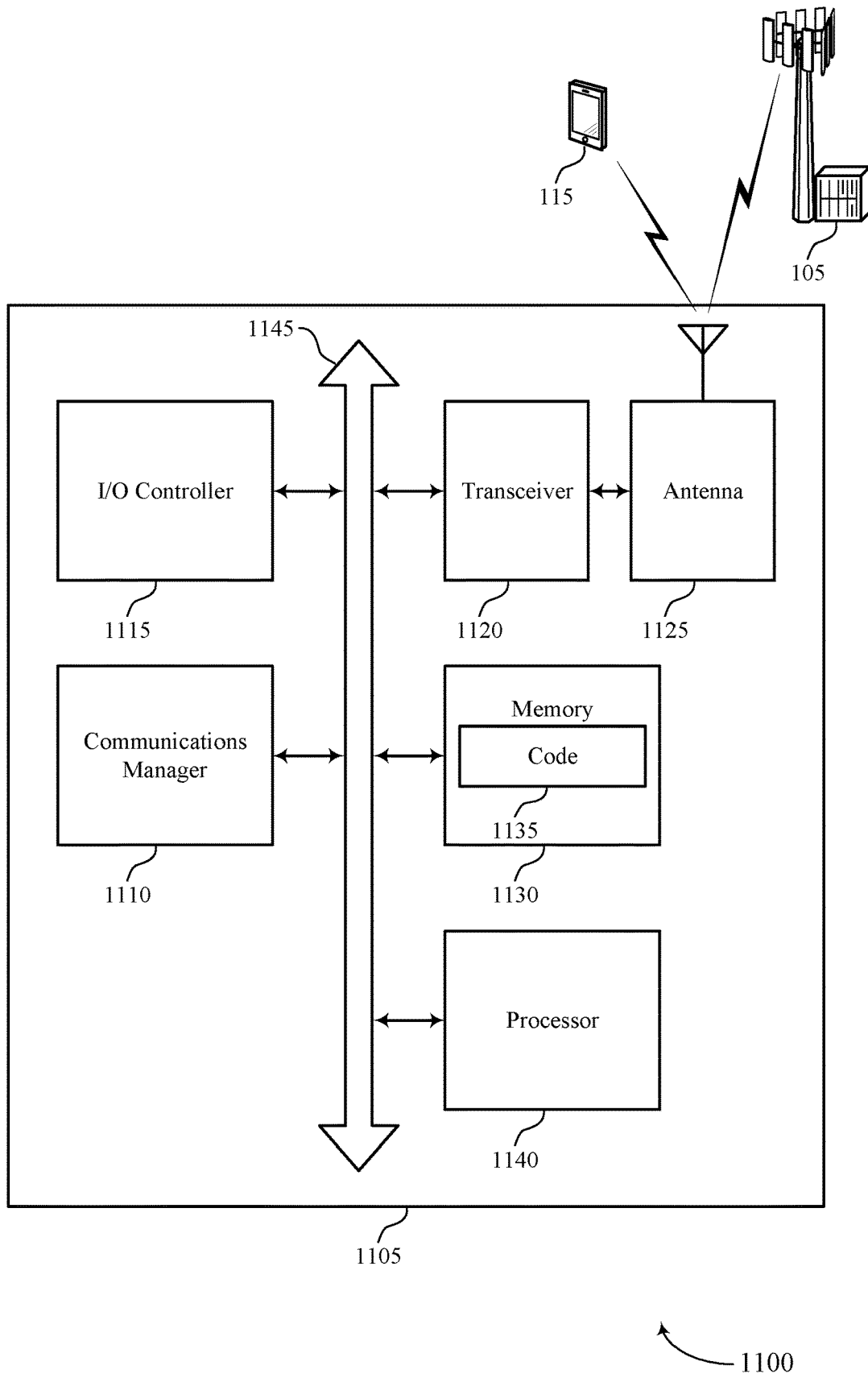

FIG. 11

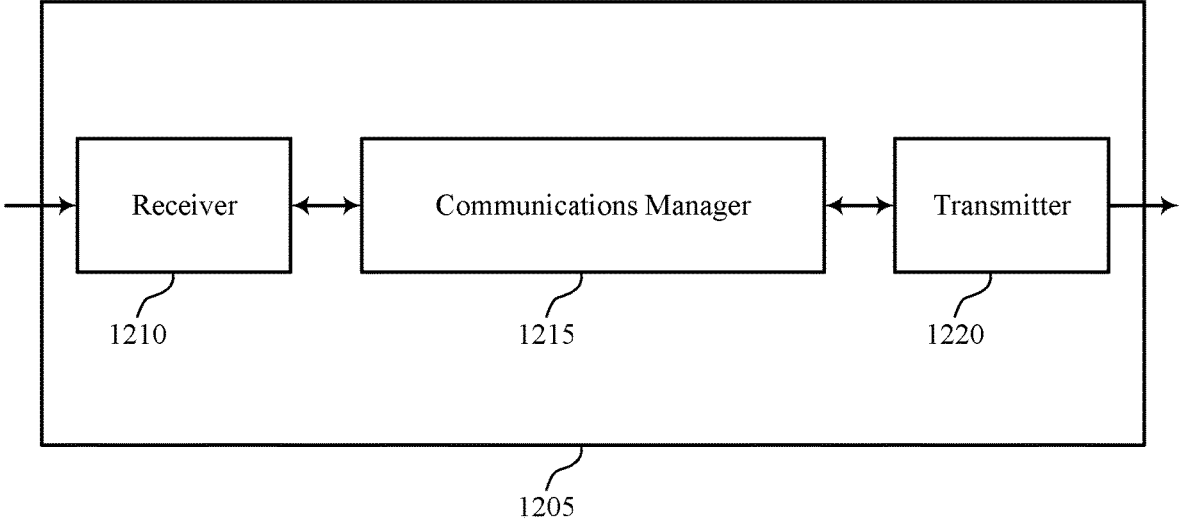

FIG. 12

1200

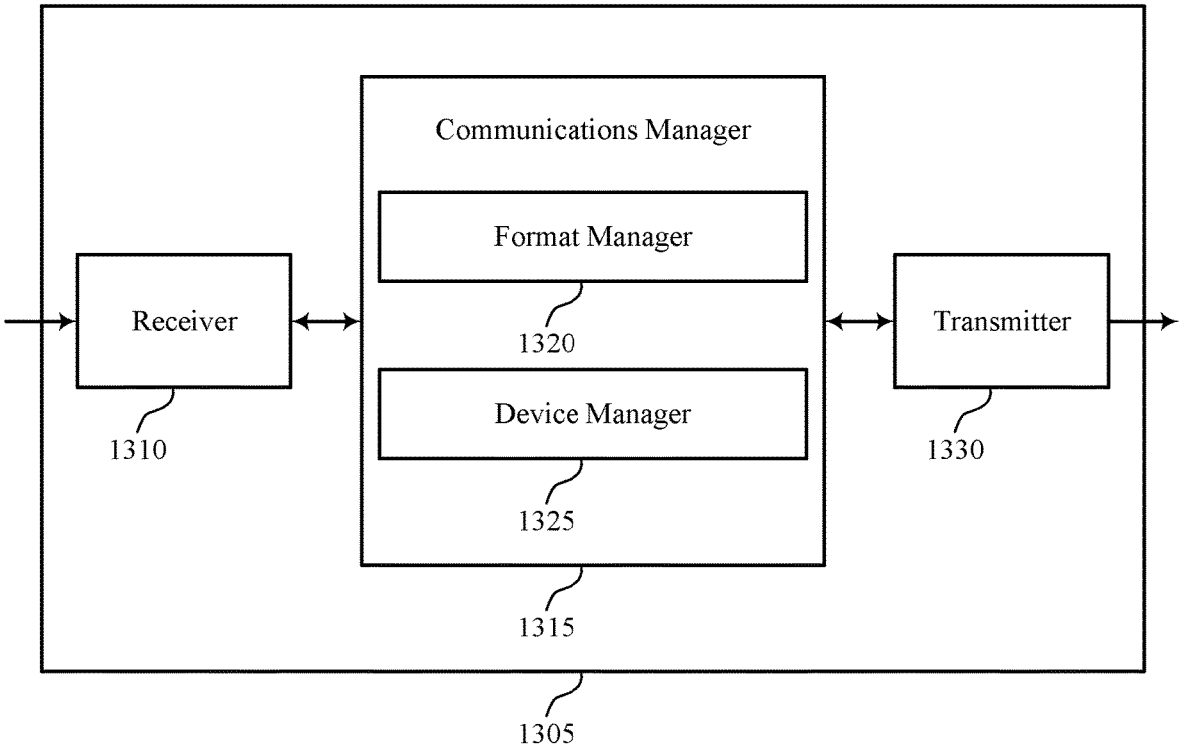

FIG. 13

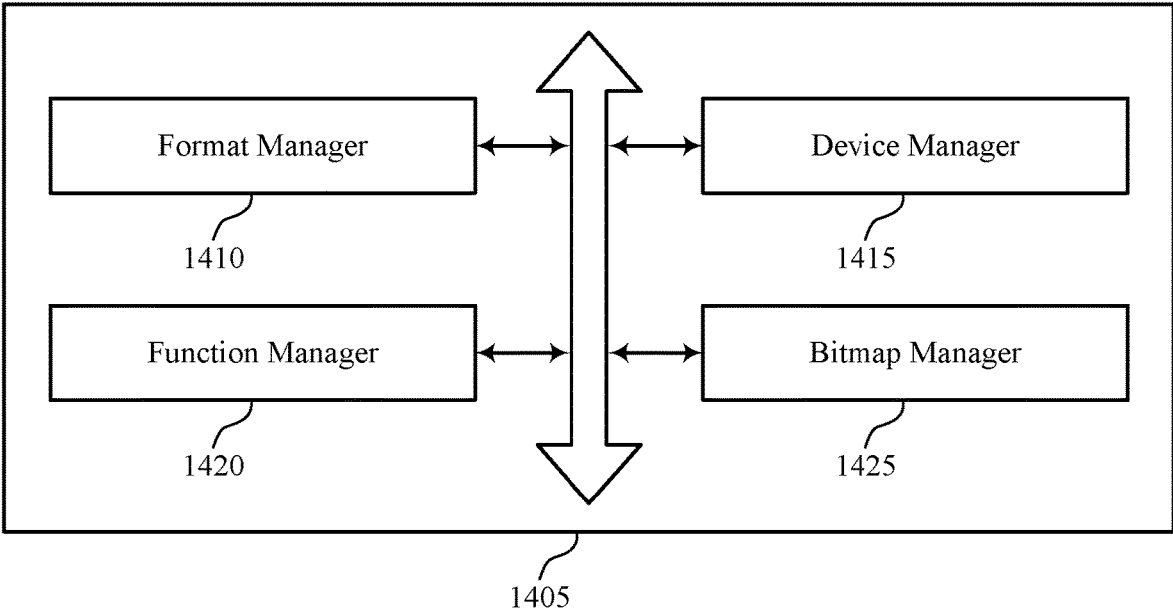

FIG. 14

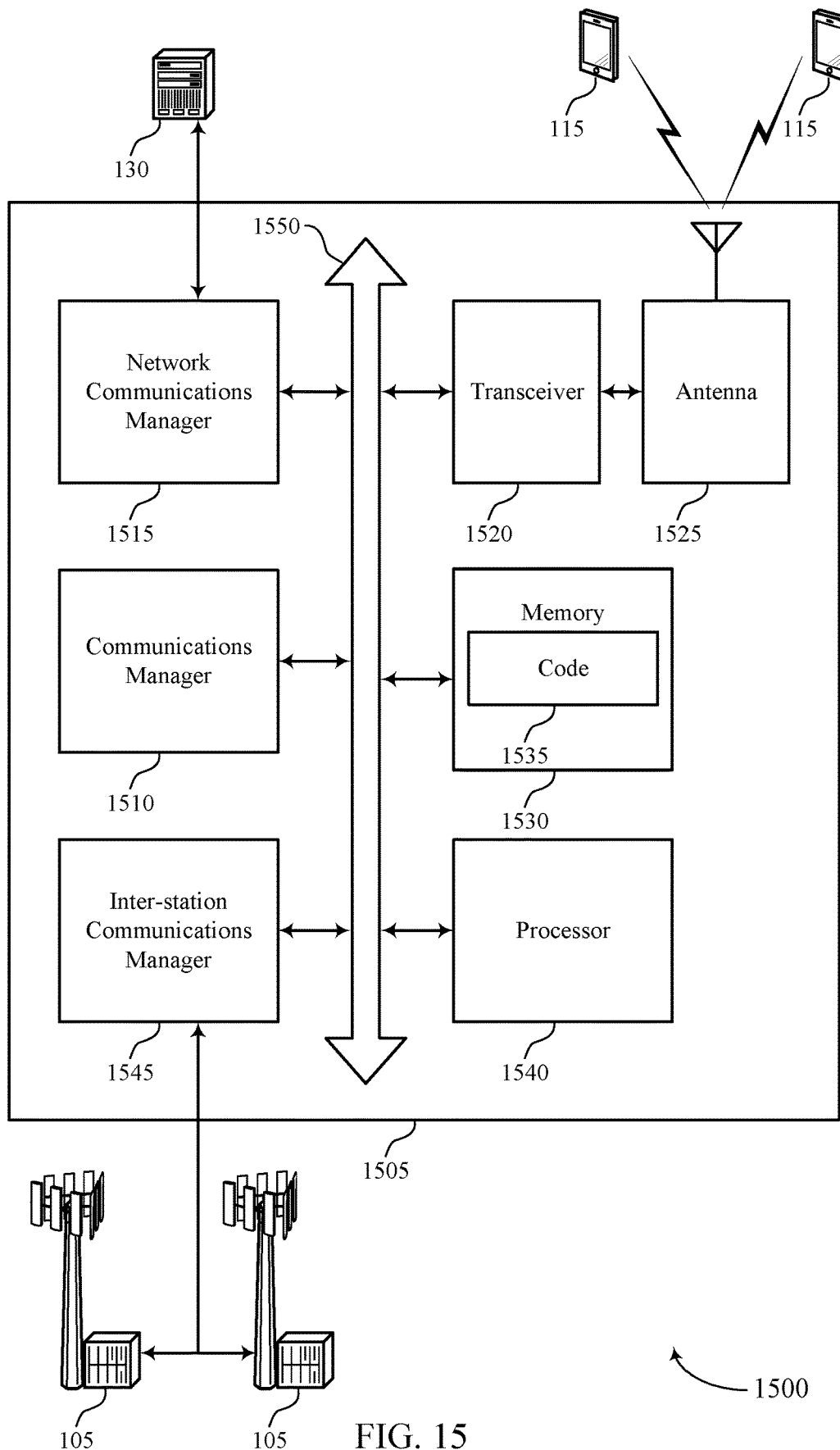

FIG. 15

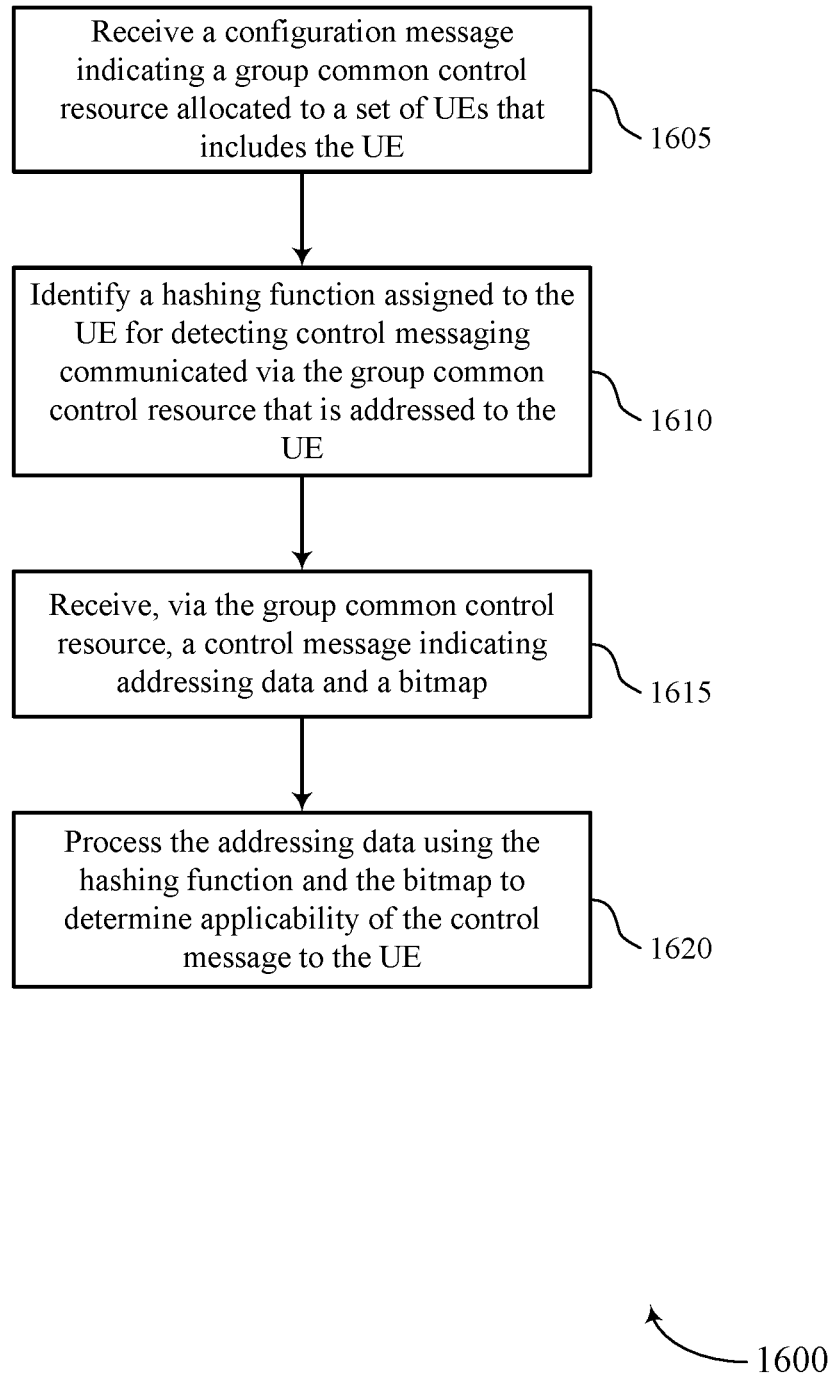

FIG. 16

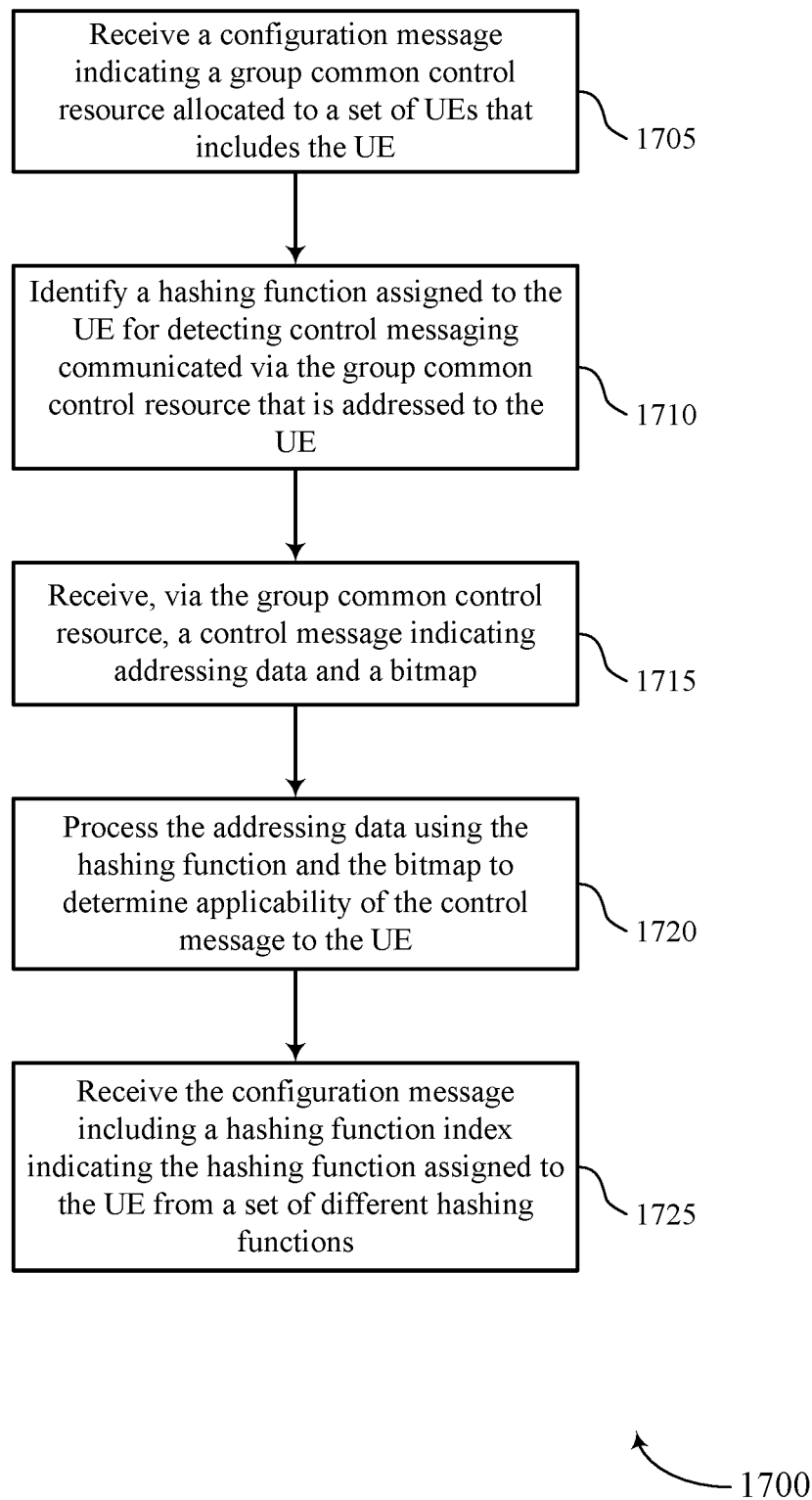

FIG. 17

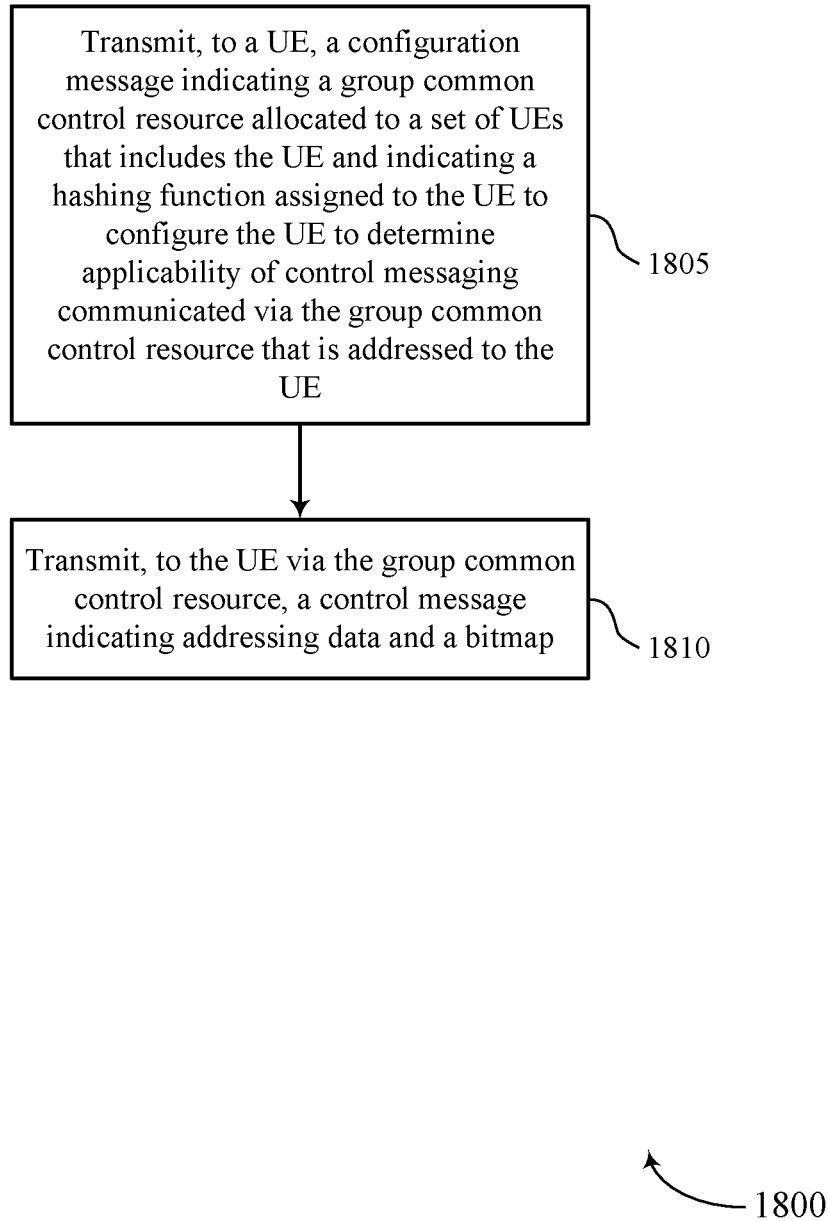

FIG. 18

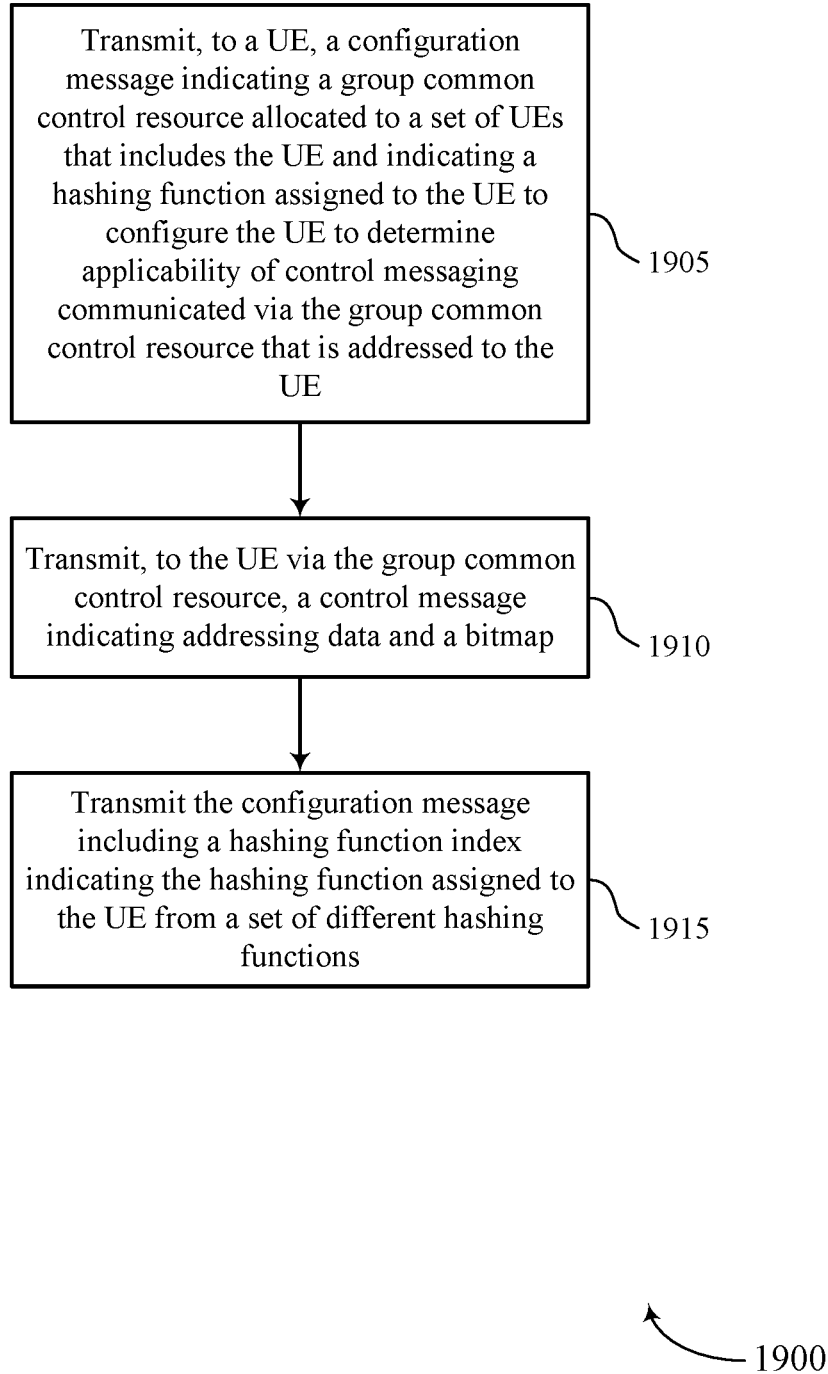

FIG. 19

1

**DYNAMIC GROUP COMMON PHYSICAL
CONTROL CHANNEL**

CROSS REFERENCE

The present Application for Patent claims the benefit of U.S. Provisional Patent Application No. 63/080,004 by XUE et al., entitled "DYNAMIC GROUP COMMON PHYSICAL CONTROL CHANNEL," filed Sep. 17, 2020, assigned to the assignee hereof, and expressly incorporated by reference herein.

FIELD OF TECHNOLOGY

The following relates to wireless communications, including dynamic group common physical control channel.

BACKGROUND

Wireless communications systems are widely deployed to provide various types of communication content such as voice, video, packet data, messaging, broadcast, and so on. These systems may be capable of supporting communication with multiple users by sharing the available system resources (e.g., time, frequency, and power). Examples of such multiple-access systems include fourth generation (4G) systems such as Long Term Evolution (LTE) systems, LTE-Advanced (LTE-A) systems, or LTE-A Pro systems, and fifth generation (5G) systems which may be referred to as New Radio (NR) systems. These systems may employ technologies such as code division multiple access (CDMA), time division multiple access (TDMA), frequency division multiple access (FDMA), orthogonal frequency division multiple access (OFDMA), or discrete Fourier transform spread orthogonal frequency division multiplexing (DFT-S-OFDM). A wireless multiple-access communications system may include one or more base stations or one or more network access nodes, each simultaneously supporting communication for multiple communication devices, which may be otherwise known as user equipment (UE).

In some examples, the number of UEs that may be addressed in a given message (e.g., control channel message) may be limited. Some systems may address a relatively low number of UEs with a given message. In some cases, the system may be associated with a group of UEs that includes a relatively large number of UEs. When the system attempts to send control information to the group of UEs, the system may have to send multiple messages where each message is addressed to different subgroups of UEs from the group of UEs.

SUMMARY

The described techniques relate to improved methods, systems, devices, and apparatuses that support dynamic group common physical control channel. Generally, the described techniques provide for a UE receiving from a base station a configuration message that indicates a group common control resource allocated to a plurality of UEs that includes the UE. In some cases, the UE may identify a hashing function assigned to the UE for detecting control messaging addressed to the UE by the base station via the group common control resource. In some cases, the UE may receive from the base station, via the group common control resource, a control message indicating addressing data and a bitmap. The UE may process the addressing data using the

2

hashing function and the bitmap to determine applicability of the control message to the UE.

A method of wireless communication by a UE is described. The method may include receiving a configuration message indicating a group common control resource allocated to a set of UEs that includes the UE, identifying a hashing function assigned to the UE for detecting control messaging communicated via the group common control resource that is addressed to the UE, receiving, via the group common control resource, a control message indicating addressing data and a bitmap, and processing the addressing data using the hashing function and the bitmap to determine applicability of the control message to the UE.

An apparatus for wireless communication by a UE is described. The apparatus may include a processor, memory coupled with the processor, and instructions stored in the memory. The instructions may be executable by the processor to cause the apparatus to receive a configuration message indicating a group common control resource allocated to a set of UEs that includes the UE, identify a hashing function assigned to the UE for detecting control messaging communicated via the group common control resource that is addressed to the UE, receive, via the group common control resource, a control message indicating addressing data and a bitmap, and process the addressing data using the hashing function and the bitmap to determine applicability of the control message to the UE.

Another apparatus for wireless communication by a UE is described. The apparatus may include means for receiving a configuration message indicating a group common control resource allocated to a set of UEs that includes the UE, identifying a hashing function assigned to the UE for detecting control messaging communicated via the group common control resource that is addressed to the UE, receiving, via the group common control resource, a control message indicating addressing data and a bitmap, and processing the addressing data using the hashing function and the bitmap to determine applicability of the control message to the UE.

A non-transitory computer-readable medium storing code for wireless communication by a UE is described. The code may include instructions executable by a processor to receive a configuration message indicating a group common control resource allocated to a set of UEs that includes the UE, identify a hashing function assigned to the UE for detecting control messaging communicated via the group common control resource that is addressed to the UE, receive, via the group common control resource, a control message indicating addressing data and a bitmap, and process the addressing data using the hashing function and the bitmap to determine applicability of the control message to the UE.

In some examples of the method, apparatuses, and non-transitory computer-readable medium described herein, identifying the hashing function may include operations, features, means, or instructions for receiving the configuration message including a hashing function index indicating the hashing function assigned to the UE from a set of different hashing functions.

In some examples of the method, apparatuses, and non-transitory computer-readable medium described herein, the hashing function index indicates a function to extract one or more bits of an identifier of the UE to identify the hashing function assigned to the UE from the set of different hashing functions.

In some examples of the method, apparatuses, and non-transitory computer-readable medium described herein,

receiving the control message may include operations, features, means, or instructions for receiving the control message indicating that the addressing data may be a random seed for input to the hashing function.

Some examples of the method, apparatuses, and non-transitory computer-readable medium described herein may further include operations, features, means, or instructions for receiving control signaling that indicates a length of the bitmap in the control message, where a hash output of the hashing function indicates a location of a bit in the bitmap based on the length of the bitmap.

Some examples of the method, apparatuses, and non-transitory computer-readable medium described herein may further include operations, features, means, or instructions for receiving control signaling that indicates a number of control segments carried in the control message.

Some examples of the method, apparatuses, and non-transitory computer-readable medium described herein may further include operations, features, means, or instructions for receiving control signaling that indicates a modulo value to apply to a hash output of the hashing function to determine a bit in the bitmap, where the bit in the bitmap indicates applicability of the control message to the UE.

Some examples of the method, apparatuses, and non-transitory computer-readable medium described herein may further include operations, features, means, or instructions for receiving control signaling that indicates a first format of a set of different formats for the control message, where the control message may be processed based on the first format.

Some examples of the method, apparatuses, and non-transitory computer-readable medium described herein may further include operations, features, means, or instructions for receiving, in the control message, a modulo value and compressed bitmap data, and determining the bitmap from the compressed bitmap data based on the modulo value and a decompression algorithm.

Some examples of the method, apparatuses, and non-transitory computer-readable medium described herein may further include operations, features, means, or instructions for receiving control signaling indicating a formula assigned to the UE, computing a group common radio network temporary identifier using the formula, and decoding the control message based on the group common radio network temporary identifier.

In some examples of the method, apparatuses, and non-transitory computer-readable medium described herein, receiving the control message may include operations, features, means, or instructions for receiving the control message indicating the bitmap that includes a first bitmap index value corresponding to a first control segment of the control message and a second bitmap index value corresponding to a second control segment of the control message.

Some examples of the method, apparatuses, and non-transitory computer-readable medium described herein may further include operations, features, means, or instructions for processing the addressing data using the hashing function and the first bitmap index value to determine applicability of the control message to the UE.

Some examples of the method, apparatuses, and non-transitory computer-readable medium described herein may further include operations, features, means, or instructions for processing the addressing data using the hashing function and the second bitmap index value to determine applicability of the control message to the UE.

In some examples of the method, apparatuses, and non-transitory computer-readable medium described herein, receiving the control message may include operations, fea-

tures, means, or instructions for receiving the control message including the addressing data that includes a first addressing seed corresponding to the first control segment and a second addressing seed corresponding to the second control segment.

Some examples of the method, apparatuses, and non-transitory computer-readable medium described herein may further include operations, features, means, or instructions for processing the first addressing seed using the hashing function and the first bitmap index value corresponding to the first control segment to determine applicability of the control message to the UE.

Some examples of the method, apparatuses, and non-transitory computer-readable medium described herein may further include operations, features, means, or instructions for processing the second addressing seed using the hashing function and the second bitmap index value corresponding to the second control segment to determine applicability of the control message to the UE.

Some examples of the method, apparatuses, and non-transitory computer-readable medium described herein may further include operations, features, means, or instructions for determining a first bit in the bitmap based on a hash output of the hashing function, and retrieving a location of a first control segment addressed to the UE of a set of control segments within the control message based on a number of bits in the bitmap preceding the first bit that a same value as the first bit.

Some examples of the method, apparatuses, and non-transitory computer-readable medium described herein may further include operations, features, means, or instructions for performing a retransmission based on information indicated in the first control segment configuring the UE to perform the retransmission.

Some examples of the method, apparatuses, and non-transitory computer-readable medium described herein may further include operations, features, means, or instructions for applying a current time, or at least a portion of an identifier of the UE, or the addressing data, or a cell radio network temporary identifier, or any combination thereof, as an input to the hashing function, and determining an output of the hashing function based on the input.

In some examples of the method, apparatuses, and non-transitory computer-readable medium described herein, the configuration message indicates the hashing function.

A method of wireless communication by a base station is described. The method may include transmitting, to a UE, a configuration message indicating a group common control resource allocated to a set of UEs that includes the UE and indicating a hashing function assigned to the UE to configure the UE to determine applicability of control messaging communicated via the group common control resource that is addressed to the UE and transmitting, to the UE via the group common control resource, a control message indicating addressing data and a bitmap.

An apparatus for wireless communication by a base station is described. The apparatus may include a processor, memory coupled with the processor, and instructions stored in the memory. The instructions may be executable by the processor to cause the apparatus to transmit, to a UE, a configuration message indicating a group common control resource allocated to a set of UEs that includes the UE and indicating a hashing function assigned to the UE to configure the UE to determine applicability of control messaging communicated via the group common control resource that is addressed to the UE and transmit, to the UE via the group

common control resource, a control message indicating addressing data and a bitmap.

Another apparatus for wireless communication by a base station is described. The apparatus may include means for transmitting, to a UE, a configuration message indicating a group common control resource allocated to a set of UEs that includes the UE and indicating a hashing function assigned to the UE to configure the UE to determine applicability of control messaging communicated via the group common control resource that is addressed to the UE and transmitting, to the UE via the group common control resource, a control message indicating addressing data and a bitmap.

A non-transitory computer-readable medium storing code for wireless communication by a base station is described. The code may include instructions executable by a processor to transmit, to a UE, a configuration message indicating a group common control resource allocated to a set of UEs that includes the UE and indicating a hashing function assigned to the UE to configure the UE to determine applicability of control messaging communicated via the group common control resource that is addressed to the UE and transmit, to the UE via the group common control resource, a control message indicating addressing data and a bitmap.

Some examples of the method, apparatuses, and non-transitory computer-readable medium described herein may further include operations, features, means, or instructions for transmitting the configuration message including a hashing function index indicating the hashing function assigned to the UE from a set of different hashing functions.

In some examples of the method, apparatuses, and non-transitory computer-readable medium described herein, the hashing function index indicates a function to extract one or more bits of an identifier of the UE to identify the hashing function assigned to the UE from the set of different hashing functions.

In some examples of the method, apparatuses, and non-transitory computer-readable medium described herein, transmitting the control message may include operations, features, means, or instructions for transmitting the control message indicating that the addressing data may be a random seed for input to the hashing function.

Some examples of the method, apparatuses, and non-transitory computer-readable medium described herein may further include operations, features, means, or instructions for transmitting control signaling that indicates a length of the bitmap in the control message, where a hash output of the hashing function indicates a location of a bit in the bitmap based on the length of the bitmap.

Some examples of the method, apparatuses, and non-transitory computer-readable medium described herein may further include operations, features, means, or instructions for transmitting control signaling that indicates a number of control segments carried in the control message, where each bit in the bitmap having a first value corresponding to a respective control segment within the control message based on the number of control segments.

Some examples of the method, apparatuses, and non-transitory computer-readable medium described herein may further include operations, features, means, or instructions for transmitting control signaling that indicates a modulo value for the UE to apply to a hash output of the hashing function to configure the UE to determine a bit in the bitmap, where the bit in the bitmap indicates applicability of the control message to the UE.

Some examples of the method, apparatuses, and non-transitory computer-readable medium described herein may further include operations, features, means, or instructions for transmitting control signaling that indicates a first format of a set of different formats for the control message to configure the UE to process the control message based on the first format.

Some examples of the method, apparatuses, and non-transitory computer-readable medium described herein may further include operations, features, means, or instructions for transmitting, in the control message, a modulo value and compressed bitmap data to configure the UE to determine the bitmap from the compressed bitmap data based on the modulo value and a decompression algorithm.

Some examples of the method, apparatuses, and non-transitory computer-readable medium described herein may further include operations, features, means, or instructions for transmitting control signaling indicating a formula assigned, by the base station, to the UE to configure the UE to compute a group common radio network temporary identifier using the formula for decoding the control message.

In some examples of the method, apparatuses, and non-transitory computer-readable medium described herein, transmitting the control message may include operations, features, means, or instructions for transmitting the control message indicating the bitmap that includes a first bitmap index value corresponding to a first control segment of the control message and a second bitmap index value corresponding to a second control segment of the control message.

In some examples of the method, apparatuses, and non-transitory computer-readable medium described herein, transmitting the control message may include operations, features, means, or instructions for transmitting the control message including the addressing data that includes a first addressing seed corresponding to the first control segment and a second addressing seed corresponding to the second control segment.

In some examples of the method, apparatuses, and non-transitory computer-readable medium described herein, a first control segment of a set of control segments within the control message configures the UE to perform a retransmission.

Some examples of the method, apparatuses, and non-transitory computer-readable medium described herein may further include operations, features, means, or instructions for receiving a retransmission from the UE based on information indicated in a first control segment that may be addressed to the UE.

In some examples of the method, apparatuses, and non-transitory computer-readable medium described herein, the configuration message indicates the hashing function.

BRIEF DESCRIPTION OF THE DRAWINGS

FIG. 1 illustrates an example of a system for wireless communications that supports dynamic group common physical control channel in accordance with aspects of the present disclosure.

FIG. 2A illustrates an example of a system for wireless communications that supports dynamic group common physical control channel in accordance with aspects of the present disclosure.

FIG. 2B illustrates an example of an environment that supports dynamic group common physical control channel in accordance with aspects of the present disclosure.

FIG. 3 illustrates an example of an environment that supports dynamic group common physical control channel in accordance with aspects of the present disclosure.

FIG. 4 illustrates an example of an environment that supports dynamic group common physical control channel in accordance with aspects of the present disclosure.

FIG. 5 illustrates an example of an environment that supports dynamic group common physical control channel in accordance with aspects of the present disclosure.

FIG. 6 illustrates an example of an environment that supports dynamic group common physical control channel in accordance with aspects of the present disclosure.

FIG. 7 illustrates an example of an environment that supports dynamic group common physical control channel in accordance with aspects of the present disclosure.

FIGS. 8 and 9 show block diagrams of devices that support dynamic group common physical control channel in accordance with aspects of the present disclosure.

FIG. 10 shows a block diagram of a communications manager that supports dynamic group common physical control channel in accordance with aspects of the present disclosure.

FIG. 11 shows a diagram of a system including a device that supports dynamic group common physical control channel in accordance with aspects of the present disclosure.

FIGS. 12 and 13 show block diagrams of devices that support dynamic group common physical control channel in accordance with aspects of the present disclosure.

FIG. 14 shows a block diagram of a communications manager that supports dynamic group common physical control channel in accordance with aspects of the present disclosure.

FIG. 15 shows a diagram of a system including a device that supports dynamic group common physical control channel in accordance with aspects of the present disclosure.

FIGS. 16 through 19 show flowcharts illustrating methods that support dynamic group common physical control channel in accordance with aspects of the present disclosure.

DETAILED DESCRIPTION

The present techniques provide improvements to operations associated with group common physical control channels. The present techniques include dynamic group common physical control channels. The amount of control information that may be included in the control message may limit the number of UEs being addressed in the control message. In some cases, the system may be associated with a group of UEs that includes a relatively large number of UEs where the system may be configured to address a subgroup of the group of UEs for retransmission. The system may send a retransmission indication to the subgroup of UEs in a control message that is monitored by all of the UEs in the group of UEs. In some cases, the bits used to address the subgroup of UEs may exceed the bits used on the control information, limiting the amount of control information that may be transmitted in a given control message.

In some cases, a physical downlink control channel may become a bottleneck for supporting the addressing a subgroup of UEs with a relatively high number of UEs from a group of UEs. For example, in a massive capacity industrial sensor network, each sensor UE is provided a configured grant (CG) uplink resource to transmit data without asking for a dynamic grant. At each CG occasion, a sensor UE randomly chooses one resource from a CG resource pool. Resource pools of different UEs can overlap to achieve statistical multiplexing. A base station may facilitate over-

loading control by turning on and/or off based on a probability of respective UEs using respective CG occasions. In some cases, each sensor UE is assigned a random (e.g., with a random seed) hash function for accessing CG resource pool, and a base station sends defined random seeds (e.g., optimized random seeds) to respective retransmitting UEs to facilitate almost orthogonal channel access. In some cases, a group common (GC)-PDCCH can be used for this purpose and the techniques described herein provide designs on dynamic group common (GC) physical control channel.

In some cases, after conducting a CG uplink transmission, a UE monitors a PDCCH for a pre-determined interval (e.g., based on initiating a timer). If the UE receives a retransmission indication before the timer expires, the UE will retransmit in accordance with the indication. Otherwise, the UE assumes its CG uplink transmission was successful. In some cases, the retransmission indication carries a UE-specific low-bit-width (e.g., 8-bit) random seed for coordinated channel access. However, using a fallback DCI with 40-bit payload can be too expensive resource-wise, especially when PDCCH is a bottleneck. GC-PDCCH may be used as an alternative, however conventional retransmission indications cannot be sent using the legacy mechanism for GC-PDCCH. In an example where the initial transmission block error rate (BLER) target is 10%, to send retransmission indications to n (e.g., 10) UEs, GC-PDCCH needs to dynamically and accurately address those UEs from about $10*n$ (e.g., 100) configured grant UEs that are monitoring the same GC-PDCCH.

When carrying dynamic or random traffics (e.g., with a large block error rate target for initial transmission that may be beneficial for relatively high throughput capacity), the UEs that are in a group of UEs being addressed (e.g., configuration grant UEs) that are monitoring the considered PDCCH may change from time to time (e.g., a UE leaves or is removed from the group, a UE is added to the group, etc.). As a result, a mechanism of PDCCH may result in transmission errors (e.g., transmission collisions, transmission delays, etc.), where the mechanism of PDCCH may include establishing a group via radio resource control, or static group index to group member, or member parsing DCI payload according to group index, or any combination thereof. Another use case is a brute force GC-PDCCH in which all adaptive configured grant uplink UEs are configured to monitor the same GC-PDCCH, which carries multiple segments, with each segment includes C-RNTI and the random seed (e.g., on how to access the CG resource pool) for a specific retransmission UE, at the cost of consuming more bits on the UE identifiers than on actual control information (e.g., random seed).

To avoid drawbacks of conventional solutions, the present techniques describe a control messaging format that enables a UE to apply a hashing function assigned to the UE for determining whether a received control message is or is not addressed to the UE. The control messaging format used in combination with assigning a particular hashing function of a set of hashing functions to a respective UE may permit a large number of UEs to be dynamically and accurately addressed. A UE may be configured (e.g., configured via pre-configuration or by network via a base station or other UE) with a hashing function for processing control messages received in a group common PDCCH (GC-PDCCH). A control message may include address data and a bitmap. The UE may apply the hashing function to the address data and may use the hash output to index to a particular bit in the bitmap. The UE may determine that the control message is addressed to the UE if the particular bit in the bitmap has a

first value (e.g., a binary 1). If the particular bit in the bitmap has a second value (e.g., a binary 0), the UE determines that the control message is not addressed to the UE. When the UE determines that it is addressed by the GC-PDCCH, the UE may retrieve a control segment from the control message.

Aspects of the disclosure are initially described in the context of wireless communications systems. Aspects of the disclosure are further illustrated by and described with reference to environment of wireless communications systems that relate to dynamic group common physical control channel. Aspects of the disclosure are further illustrated by and described with reference to apparatus diagrams, system diagrams, and flowcharts that relate to dynamic group common physical control channel.

FIG. 1 illustrates an example of a wireless communications system **100** that supports dynamic group common physical control channel in accordance with aspects of the present disclosure. The wireless communications system **100** may include one or more base stations **105**, one or more UEs **115**, and a core network **130**. In some examples, the wireless communications system **100** may be a Long Term Evolution (LTE) network, an LTE-Advanced (LTE-A) network, an LTE-A Pro network, or a New Radio (NR) network. In some examples, the wireless communications system **100** may support enhanced broadband communications, ultra-reliable (e.g., mission critical) communications, low latency communications, communications with low-cost and low-complexity devices, or any combination thereof.

The base stations **105** may be dispersed throughout a geographic area to form the wireless communications system **100** and may be devices in different forms or having different capabilities. The base stations **105** and the UEs **115** may wirelessly communicate via one or more communication links **125**. Each base station **105** may provide a coverage area **110** over which the UEs **115** and the base station **105** may establish one or more communication links **125**. The coverage area **110** may be an example of a geographic area over which a base station **105** and a UE **115** may support the communication of signals according to one or more radio access technologies.

The UEs **115** may be dispersed throughout a coverage area **110** of the wireless communications system **100**, and each UE **115** may be stationary, or mobile, or both at different times. The UEs **115** may be devices in different forms or having different capabilities. Some example UEs **115** are illustrated in FIG. 1. The UEs **115** described herein may be able to communicate with various types of devices, such as other UEs **115**, the base stations **105**, or network equipment (e.g., core network nodes, relay devices, integrated access and backhaul (IAB) nodes, or other network equipment), as shown in FIG. 1.

The base stations **105** may communicate with the core network **130**, or with one another, or both. For example, the base stations **105** may interface with the core network **130** through one or more backhaul links **120** (e.g., via an S1, N2, N3, or other interface). The base stations **105** may communicate with one another over the backhaul links **120** (e.g., via an X2, Xn, or other interface) either directly (e.g., directly between base stations **105**), or indirectly (e.g., via core network **130**), or both. In some examples, the backhaul links **120** may be or include one or more wireless links.

One or more of the base stations **105** described herein may include or may be referred to by a person having ordinary skill in the art as a base transceiver station, a radio base station, an access point, a radio transceiver, a NodeB, an eNodeB (eNB), a next-generation NodeB or a giga-NodeB

(either of which may be referred to as a gNB), a Home NodeB, a Home eNodeB, or other suitable terminology.

A UE **115** may include or may be referred to as a mobile device, a wireless device, a remote device, a handheld device, or a subscriber device, or some other suitable terminology, where the “device” may also be referred to as a unit, a station, a terminal, or a client, among other examples. A UE **115** may also include or may be referred to as a personal electronic device such as a cellular phone, a personal digital assistant (PDA), a tablet computer, a laptop computer, or a personal computer. In some examples, a UE **115** may include or be referred to as a wireless local loop (WLL) station, an Internet of Things (IoT) device, an Internet of Everything (IoE) device, or a machine type communications (MTC) device, among other examples, which may be implemented in various objects such as appliances, or vehicles, meters, among other examples.

The UEs **115** described herein may be able to communicate with various types of devices, such as other UEs **115** that may sometimes act as relays as well as the base stations **105** and the network equipment including macro eNBs or gNBs, small cell eNBs or gNBs, or relay base stations, among other examples, as shown in FIG. 1.

The UEs **115** and the base stations **105** may wirelessly communicate with one another via one or more communication links **125** over one or more carriers. The term “carrier” may refer to a set of radio frequency spectrum resources having a defined physical layer structure for supporting the communication links **125**. For example, a carrier used for a communication link **125** may include a portion of a radio frequency spectrum band (e.g., a bandwidth part (BWP)) that is operated according to one or more physical layer channels for a given radio access technology (e.g., LTE, LTE-A, LTE-A Pro, NR). Each physical layer channel may carry acquisition signaling (e.g., synchronization signals, system information), control signaling that coordinates operation for the carrier, user data, or other signaling. The wireless communications system **100** may support communication with a UE **115** using carrier aggregation or multi-carrier operation. A UE **115** may be configured with multiple downlink component carriers and one or more uplink component carriers according to a carrier aggregation configuration. Carrier aggregation may be used with both frequency division duplexing (FDD) and time division duplexing (TDD) component carriers.

Signal waveforms transmitted over a carrier may be made up of multiple subcarriers (e.g., using multi-carrier modulation (MCM) techniques such as orthogonal frequency division multiplexing (OFDM) or discrete Fourier transform spread OFDM (DFT-S-OFDM)). In a system employing MCM techniques, a resource element may consist of one symbol period (e.g., a duration of one modulation symbol) and one subcarrier, where the symbol period and subcarrier spacing are inversely related. The number of bits carried by each resource element may depend on the modulation scheme (e.g., the order of the modulation scheme, the coding rate of the modulation scheme, or both). Thus, the more resource elements that a UE **115** receives and the higher the order of the modulation scheme, the higher the data rate may be for the UE **115**. A wireless communications resource may refer to a combination of a radio frequency spectrum resource, a time resource, and a spatial resource (e.g., spatial layers or beams), and the use of multiple spatial layers may further increase the data rate or data integrity for communications with a UE **115**.

The time intervals for the base stations **105** or the UEs **115** may be expressed in multiples of a basic time unit which

may, for example, refer to a sampling period of $T_s=1/(\Delta f_{max} N_f)$ seconds, where Δf_{max} may represent the maximum supported subcarrier spacing, and N_f may represent the maximum supported discrete Fourier transform (DFT) size. Time intervals of a communications resource may be organized according to radio frames each having a specified duration (e.g., 10 milliseconds (ms)). Each radio frame may be identified by a system frame number (SFN) (e.g., ranging from 0 to 1023).

Each frame may include multiple consecutively numbered subframes or slots, and each subframe or slot may have the same duration. In some examples, a frame may be divided (e.g., in the time domain) into subframes, and each subframe may be further divided into a number of slots. Alternatively, each frame may include a variable number of slots, and the number of slots may depend on subcarrier spacing. Each slot may include a number of symbol periods (e.g., depending on the length of the cyclic prefix prepended to each symbol period). In some wireless communications systems **100**, a slot may further be divided into multiple mini-slots containing one or more symbols. Excluding the cyclic prefix, each symbol period may contain one or more (e.g., N_f) sampling periods. The duration of a symbol period may depend on the subcarrier spacing or frequency band of operation.

A subframe, a slot, a mini-slot, or a symbol may be the smallest scheduling unit (e.g., in the time domain) of the wireless communications system **100** and may be referred to as a transmission time interval (TTI). In some examples, the TTI duration (e.g., the number of symbol periods in a TTI) may be variable. Additionally or alternatively, the smallest scheduling unit of the wireless communications system **100** may be dynamically selected (e.g., in bursts of shortened TTIs (sTTIs)).

Physical channels may be multiplexed on a carrier according to various techniques. A physical control channel and a physical data channel may be multiplexed on a downlink carrier, for example, using one or more of time division multiplexing (TDM) techniques, frequency division multiplexing (FDM) techniques, or hybrid TDM-FDM techniques. A control region (e.g., a control resource set (CORESET)) for a physical control channel may be defined by a number of symbol periods and may extend across the system bandwidth or a subset of the system bandwidth of the carrier. One or more control regions (e.g., CORESETs) may be configured for a set of the UEs **115**. For example, one or more of the UEs **115** may monitor or search control regions for control information according to one or more search space sets, and each search space set may include one or multiple control channel candidates in one or more aggregation levels arranged in a cascaded manner. An aggregation level for a control channel candidate may refer to a number of control channel resources (e.g., control channel elements (CCEs)) associated with encoded information for a control information format having a given payload size. Search space sets may include common search space sets configured for sending control information to multiple UEs **115** and UE-specific search space sets for sending control information to a specific UE **115**.

Each base station **105** may provide communication coverage via one or more cells, for example a macro cell, a small cell, a hot spot, or other types of cells, or any combination thereof. The term "cell" may refer to a logical communication entity used for communication with a base station **105** (e.g., over a carrier) and may be associated with an identifier for distinguishing neighboring cells (e.g., a physical cell identifier (PCID), a virtual cell identifier (VCID), or others).

In some examples, a cell may also refer to a geographic coverage area **110** or a portion of a geographic coverage area **110** (e.g., a sector) over which the logical communication entity operates. Such cells may range from smaller areas (e.g., a structure, a subset of structure) to larger areas depending on various factors such as the capabilities of the base station **105**. For example, a cell may be or include a building, a subset of a building, or exterior spaces between or overlapping with geographic coverage areas **110**, among other examples.

A macro cell generally covers a relatively large geographic area (e.g., several kilometers in radius) and may allow unrestricted access by the UEs **115** with service subscriptions with the network provider supporting the macro cell. A small cell may be associated with a lower-powered base station **105**, as compared with a macro cell, and a small cell may operate in the same or different (e.g., licensed, unlicensed) frequency bands as macro cells. Small cells may provide unrestricted access to the UEs **115** with service subscriptions with the network provider or may provide restricted access to the UEs **115** having an association with the small cell (e.g., the UEs **115** in a closed subscriber group (CSG), the UEs **115** associated with users in a home or office). A base station **105** may support one or multiple cells and may also support communications over the one or more cells using one or multiple component carriers.

In some examples, a carrier may support multiple cells, and different cells may be configured according to different protocol types (e.g., MTC, narrowband IoT (NB-IoT), enhanced mobile broadband (eMBB)) that may provide access for different types of devices.

In some examples, a base station **105** may be movable and therefore provide communication coverage for a moving geographic coverage area **110**. In some examples, different geographic coverage areas **110** associated with different technologies may overlap, but the different geographic coverage areas **110** may be supported by the same base station **105**. In other examples, the overlapping geographic coverage areas **110** associated with different technologies may be supported by different base stations **105**. The wireless communications system **100** may include, for example, a heterogeneous network in which different types of the base stations **105** provide coverage for various geographic coverage areas **110** using the same or different radio access technologies.

Some UEs **115**, such as MTC or IoT devices, may be low cost or low complexity devices and may provide for automated communication between machines (e.g., via Machine-to-Machine (M2M) communication). M2M communication or MTC may refer to data communication technologies that allow devices to communicate with one another or a base station **105** without human intervention. In some examples, M2M communication or MTC may include communications from devices that integrate sensors or meters to measure or capture information and relay such information to a central server or application program that makes use of the information or presents the information to humans interacting with the application program. Some UEs **115** may be designed to collect information or enable automated behavior of machines or other devices. Examples of applications for MTC devices include smart metering, inventory monitoring, water level monitoring, equipment monitoring, healthcare monitoring, wildlife monitoring, weather and geological event monitoring, fleet management and tracking, remote security sensing, physical access control, and transaction-based business charging.

Some UEs **115** may be configured to employ operating modes that reduce power consumption, such as half-duplex communications (e.g., a mode that supports one-way communication via transmission or reception, but not transmission and reception simultaneously). In some examples, half-duplex communications may be performed at a reduced peak rate. Other power conservation techniques for the UEs **115** include entering a power saving deep sleep mode when not engaging in active communications, operating over a limited bandwidth (e.g., according to narrowband communications), or a combination of these techniques. For example, some UEs **115** may be configured for operation using a narrowband protocol type that is associated with a defined portion or range (e.g., set of subcarriers or resource blocks (RBs)) within a carrier, within a guard-band of a carrier, or outside of a carrier.

The wireless communications system **100** may be configured to support ultra-reliable communications or low-latency communications, or various combinations thereof. For example, the wireless communications system **100** may be configured to support ultra-reliable low-latency communications (URLLC) or mission critical communications. The UEs **115** may be designed to support ultra-reliable, low-latency, or critical functions (e.g., mission critical functions). Ultra-reliable communications may include private communication or group communication and may be supported by one or more mission critical services such as mission critical push-to-talk (MCPTT), mission critical video (MCVideo), or mission critical data (MCDATA). Support for mission critical functions may include prioritization of services, and mission critical services may be used for public safety or general commercial applications. The terms ultra-reliable, low-latency, mission critical, and ultra-reliable low-latency may be used interchangeably herein.

In some examples, a UE **115** may also be able to communicate directly with other UEs **115** over a device-to-device (D2D) communication link **135** (e.g., using a peer-to-peer (P2P) or D2D protocol). One or more UEs **115** utilizing D2D communications may be within the geographic coverage area **110** of a base station **105**. Other UEs **115** in such a group may be outside the geographic coverage area **110** of a base station **105** or be otherwise unable to receive transmissions from a base station **105**. In some examples, groups of the UEs **115** communicating via D2D communications may utilize a one-to-many (1:M) system in which each UE **115** transmits to every other UE **115** in the group. In some examples, a base station **105** facilitates the scheduling of resources for D2D communications. In other cases, D2D communications are carried out between the UEs **115** without the involvement of a base station **105**.

The core network **130** may provide user authentication, access authorization, tracking, Internet Protocol (IP) connectivity, and other access, routing, or mobility functions. The core network **130** may be an evolved packet core (EPC) or 5G core (5GC), which may include at least one control plane entity that manages access and mobility (e.g., a mobility management entity (MME), an access and mobility management function (AMF)) and at least one user plane entity that routes packets or interconnects to external networks (e.g., a serving gateway (S-GW), a Packet Data Network (PDN) gateway (P-GW), or a user plane function (UPF)). The control plane entity may manage non-access stratum (NAS) functions such as mobility, authentication, and bearer management for the UEs **115** served by the base stations **105** associated with the core network **130**. User IP packets may be transferred through the user plane entity, which may provide IP address allocation as well as other

functions. The user plane entity may be connected to IP services **150** for one or more network operators. The IP services **150** may include access to the Internet, Intranet(s), an IP Multimedia Subsystem (IMS), or a Packet-Switched Streaming Service.

Some of the network devices, such as a base station **105**, may include subcomponents such as an access network entity **140**, which may be an example of an access node controller (ANC). Each access network entity **140** may communicate with the UEs **115** through one or more other access network transmission entities **145**, which may be referred to as radio heads, smart radio heads, or transmission/reception points (TRPs). Each access network transmission entity **145** may include one or more antenna panels. In some configurations, various functions of each access network entity **140** or base station **105** may be distributed across various network devices (e.g., radio heads and ANCs) or consolidated into a single network device (e.g., a base station **105**).

The wireless communications system **100** may operate using one or more frequency bands, typically in the range of 300 megahertz (MHz) to 300 gigahertz (GHz). Generally, the region from 300 MHz to 3 GHz is known as the ultra-high frequency (UHF) region or decimeter band because the wavelengths range from approximately one decimeter to one meter in length. The UHF waves may be blocked or redirected by buildings and environmental features, but the waves may penetrate structures sufficiently for a macro cell to provide service to the UEs **115** located indoors. The transmission of UHF waves may be associated with smaller antennas and shorter ranges (e.g., less than 100 kilometers) compared to transmission using the smaller frequencies and longer waves of the high frequency (HF) or very high frequency (VHF) portion of the spectrum below 300 MHz.

The wireless communications system **100** may utilize both licensed and unlicensed radio frequency spectrum bands. For example, the wireless communications system **100** may employ License Assisted Access (LAA), LTE-Unlicensed (LTE-U) radio access technology, or NR technology in an unlicensed band such as the 5 GHz industrial, scientific, and medical (ISM) band. When operating in unlicensed radio frequency spectrum bands, devices such as the base stations **105** and the UEs **115** may employ carrier sensing for collision detection and avoidance. In some examples, operations in unlicensed bands may be based on a carrier aggregation configuration in conjunction with component carriers operating in a licensed band (e.g., LAA). Operations in unlicensed spectrum may include downlink transmissions, uplink transmissions, P2P transmissions, or D2D transmissions, among other examples.

A base station **105** or a UE **115** may be equipped with multiple antennas, which may be used to employ techniques such as transmit diversity, receive diversity, multiple-input multiple-output (MIMO) communications, or beamforming. The antennas of a base station **105** or a UE **115** may be located within one or more antenna arrays or antenna panels, which may support MIMO operations or transmit or receive beamforming. For example, one or more base station antennas or antenna arrays may be co-located at an antenna assembly, such as an antenna tower. In some examples, antennas or antenna arrays associated with a base station **105** may be located in diverse geographic locations. A base station **105** may have an antenna array with a number of rows and columns of antenna ports that the base station **105** may use to support beamforming of communications with a UE **115**. Likewise, a UE **115** may have one or more antenna

arrays that may support various MIMO or beamforming operations. Additionally or alternatively, an antenna panel may support radio frequency beamforming for a signal transmitted via an antenna port.

Beamforming, which may also be referred to as spatial filtering, directional transmission, or directional reception, is a signal processing technique that may be used at a transmitting device or a receiving device (e.g., a base station **105**, a UE **115**) to shape or steer an antenna beam (e.g., a transmit beam, a receive beam) along a spatial path between the transmitting device and the receiving device. Beamforming may be achieved by combining the signals communicated via antenna elements of an antenna array such that some signals propagating at particular orientations with respect to an antenna array experience constructive interference while others experience destructive interference. The adjustment of signals communicated via the antenna elements may include a transmitting device or a receiving device applying amplitude offsets, phase offsets, or both to signals carried via the antenna elements associated with the device. The adjustments associated with each of the antenna elements may be defined by a beamforming weight set associated with a particular orientation (e.g., with respect to the antenna array of the transmitting device or receiving device, or with respect to some other orientation).

The wireless communications system **100** may be a packet-based network that operates according to a layered protocol stack. In the user plane, communications at the bearer or Packet Data Convergence Protocol (PDCP) layer may be IP-based. A Radio Link Control (RLC) layer may perform packet segmentation and reassembly to communicate over logical channels. A Medium Access Control (MAC) layer may perform priority handling and multiplexing of logical channels into transport channels. The MAC layer may also use error detection techniques, error correction techniques, or both to support retransmissions at the MAC layer to improve link efficiency. In the control plane, the Radio Resource Control (RRC) protocol layer may provide establishment, configuration, and maintenance of an RRC connection between a UE **115** and a base station **105** or a core network **130** supporting radio bearers for user plane data. At the physical layer, transport channels may be mapped to physical channels.

The UEs **115** and the base stations **105** may support retransmissions of data to increase the likelihood that data is received successfully. Hybrid automatic repeat request (HARQ) feedback is one technique for increasing the likelihood that data is received correctly over a communication link **125**. HARQ may include a combination of error detection (e.g., using a cyclic redundancy check (CRC)), forward error correction (FEC), and retransmission (e.g., automatic repeat request (ARQ)). HARQ may improve throughput at the MAC layer in poor radio conditions (e.g., low signal-to-noise conditions). In some examples, a device may support same-slot HARQ feedback, where the device may provide HARQ feedback in a specific slot for data received in a previous symbol in the slot. In other cases, the device may provide HARQ feedback in a subsequent slot, or according to some other time interval.

In some examples, a base station **105** may transmit, to a UE **115**, a configuration message indicating a group common control resource allocated to a group of UEs (e.g., a subgroup of UEs) that includes the UE **115**. The configuration message may indicate a hashing function assigned to the UE **115** to configure the UE **115** to determine applicability of control messaging communicated via the group common control resource that is addressed to the UE **115**.

Thus, in some examples, the UE **115** may receive the configuration message from base station **105** where the configuration message indicates a control resource (e.g., a group common control resource) allocated to the group of UEs (e.g., subgroup of UEs) that includes the UE **115**. In some cases, the UE **115** may identify a hashing function assigned to the UE **115** for detecting control messaging communicated via the group common control resource that is addressed to the UE **115**. In some examples, the base station **105** may transmit to the UE **115**, via the group common control resource, a control message indicating addressing data and a bitmap. The UE **115** may receive from base station **105**, via the group common control resource, the control message indicating the addressing data and the bitmap. The UE **115** may process the addressing data using the hashing function and the bitmap to determine applicability of the control message to the UE **115**.

FIG. 2A illustrates an example of an environment **200A** that supports dynamic group common physical control channel in accordance with aspects of the present disclosure. In some examples, environment **200A** may implement aspects of wireless communication system **100**. As illustrated, environment **200A** may include base station **105-a** and a UE **115-a**, which may be examples of corresponding devices as described herein. The UE **115-a** and the base station **105-a** may communicate via a communication link **205** within a geographic coverage area **110-a**.

In some examples, base station **105-a** may transmit to UE **115-a**, one or more configuration messages (e.g., configuration message **210**). The base station **105-a** may transmit the configuration in control signaling (e.g., a RRC message). In some cases, configuration message **210** may indicate a group common control resource allocated to a group of UEs (e.g., a subgroup of UEs) that includes UE **115-a**. The configuration message **210** may indicate a hashing function assigned at least to UE **115-a**. In some cases, the configuration message **210** may include the hashing function. In some cases, a group of UEs including UE **115-a** (e.g., a subgroup of UEs of a group of UEs) may be preconfigured with the hashing function. In some cases, the group of UEs including UE **115-a** may be preconfigured with multiple hashing functions and the configuration message **210** may indicate (e.g., a flag or bit value in configuration message **210** may indicate) which of the multiple hashing functions to use. In some cases, the configuration message **210** may indicate the same hashing function for each of the UEs in the group of UEs to use. In some cases, the configuration message **210** may indicate a first hashing function for a first UE (e.g., UE **115-a**) to use, and a second hashing function, different from the first hashing function, for a second UE to use.

In some examples, a configuration message (e.g., configuration message **210**) may include a hashing function index that indicates the hashing function assigned to a corresponding UE (e.g., UE **115-a** or UE **115-b**, or both) among multiple different hashing functions. In some cases, the hashing function index may indicate a function to extract one or more bits of an identifier of a corresponding UE to identify the hashing function assigned to the corresponding UE among multiple different hashing functions (e.g., hashing functions preconfigured on the corresponding UE).

In some examples, the configuration message **210** may include configuration information that configures UE **115-a** or enables UE **115-a** to configure itself to determine applicability of control messaging (e.g., control message **215**) communicated via the group common control resource that is addressed to UE **115-a**. In some cases, UE **115-a** may

receive the configuration message **210** indicating the group common control resource allocated to the group of UEs that includes UE **115-a**. In some cases, the UE **115-a** may identify, based at least in part on the configuration message **210**, a hashing function assigned to the UE **115-a**. In some cases, the hashing function may configure UE **115-a** to detect control messaging (e.g., control message **215**) that is communicated via the group common control resource that is addressed to the UE **115-a**.

In some examples, base station **105-a** may transmit to UE **115-a**, via the group common control resource, control message **215**. In some cases, control message **215** may indicate control information (e.g., addressing data, bitmap, one or more control segments, etc.). In some cases, base station **105-a** may transmit the control message **215** to UE **115-a** after transmitting the configuration message **210** to UE **115-a**. In some cases, UE **115-a** may receive control message **215** indicating addressing data and a bitmap, and process the addressing data using the hashing function and the bitmap to determine applicability of the control message **215** to the UE **115-a**.

FIG. 2B illustrates an example of an environment **200B** that supports dynamic group common physical control channel in accordance with aspects of the present disclosure. In some examples, environment **200B** may implement aspects of wireless communication system **100**. In some examples, environment **200B** may include a control message **215** that includes a single seed and a single bitmap.

As illustrated, environment **200B** may include control message **215**, UE **115-a**, and UE **115-b**. As shown, control message **215** may include addressing random seed field **220**, bitmap **225**, and control segment **230**. In some cases, bitmap **225** may be a variable-length bitmap that includes two or more bits. In some cases, the environment **200B** provides a random hash-based solution that improves the efficiency of a control channel (e.g., group common physical downlink control channel (GC-PDCCH)) in addressing multiple UEs.

In some examples, control message **215** may be addressed to a subgroup of UEs from a group of UEs that includes UE **115-a** and UE **115-b**. In some cases, the subgroup of UEs may include UE **115-a** or UE **115-b**, or both. In some examples, control message **215** may be addressed to a subgroup of UEs that includes UE **115-a** and **115-b**; or addressed to a subgroup of UEs that includes UE **115-a**, but not **115-b**; or addressed to a subgroup of UEs that includes UE **115-b**, but not **115-a**; or addressed to a subgroup of UEs that does not include UE **115-a** or **115-b**. In some examples, the group of UEs may include a group of configuration grant (CG) UEs (e.g., a group of CG uplink UEs). In some cases, the group of CG UEs may include UE **115-a** or UE **115-b**, or both.

In some examples, base station **105-a** may assign at least the subgroup of UEs a random hashing function for addressing in control messages (e.g., GC-PDCCH messages, control message **215**, etc.). For example, a UE can be configured (e.g., by the network or pre-configuration) with a random hash function to detect whether the is addressed by a group common (GC) physical control channel. In some cases, each UE may be assigned a unique hash function, or multiple UEs may be assigned a same hash function. In some cases, the hashing function may include one or more inputs. The one or more inputs to the hashing function may include a UE identifier (e.g., an identifier of UE **115-a** when UE **115-a** computes the hashing function, an identifier of UE **115-b** when UE **115-b** computes the hashing function), or a timing value (e.g., a current time, a timestamp included in the control message, a timestamp of when the control message

is sent, etc.), or a random seed (e.g., a random seed from addressing random seed field **220**, a cell radio network temporary identifier), or any combination thereof. In some examples, a configuration message (e.g., configuration message **210**) may indicate that a UE uses a default random number (e.g., preconfigured default random number, default random number obtained via layer 1, etc.) in computing the hashing function. In an example of a single hash function, the hash function may have inputs of a 16-bit C-RNTI and 16-bit random seed. To generate a hash output, the hash function may first build a 4-byte string using the inputs, second calculate a 32-bit CRC of the 4-byte string, denoted as S , and third output $\text{mod}(S, L)$, where L is a pre-configured integer as a modulo value for the $\text{mod}(S, L)$ function. It is noted that different random seeds may lead to different pairs of hash output.

In some examples, control segment **230** may include UE-specific information indicating how to conduct a re-transmission (e.g., information for accessing a GC resource pool). In some cases, control segment **230** may include one or more control segments. In some cases, a first control segment of control segment **230** may correspond to UE **115-a** (e.g., a first control segment with UE-specific information that is specific to UE **115-a**), and a second control segment of control segment **230** may correspond to UE **115-b** (e.g., a second control segment with UE-specific information specific to UE **115-b**, etc.).

Upon receiving control message **215** (e.g., in a GC-PDCCH resource), a UE (e.g., UE **115-a**, UE **115-b**) may compute an output of the hashing function that is indicated by configuration message **210**. In some cases, the UE may use the output of the hashing function as an index to look up a corresponding bit value in the bitmap **225**. In some examples, a corresponding bit value of "0" may indicate that the respective UE is to disregard the control message (e.g., control message **215**). In some examples, a corresponding bit value of "1" may indicate the UE is to conduct a re-transmission according to information (e.g., re-transmission configuration information) in the control segment **230** (e.g., UE-specific information). In some cases, a bit value of "1" may indicate that the respective UE is to disregard the control message, while a bit value of "0" may indicate the UE is to conduct a re-transmission according to information.

In some examples, a corresponding bit value of "1" in the bitmap **225** may indicate the corresponding UE, or up to all UEs, may be configured to retrieve (e.g., indicated to retrieve) the entire control segment **230** (e.g., entire content of control segment **230** or multiple control segments of the control message **215**). In some examples, a configuration of the control segment **230** retrieval operation may be pre-configured by layer 1 above signaling, or over the air (OTA) in a group common physical control channel, etc. In some cases, one or more rules (e.g., re-transmission rules) may be specified in control segment **230** (e.g., at least a part of control segment **230**) for control message dispatching among corresponding UEs.

In the illustrated example, UE **115-a** may compute the output of the hashing function and use the output as an index to determine a bit value in the bitmap **225** corresponding to UE **115-a** is "0." Accordingly, UE **115-a** may disregard the control message (e.g., control message **215**, skip or discard a GC-PDCCH control message, etc.) based on the corresponding bit value being "0." In the illustrated example, UE **115-b** may compute the output of the hashing function and use the output as an index to determine a bit value in the bitmap **225** corresponding to UE **115-b** is "1." Accordingly, UE **115-b** may conduct a re-transmission according to

information (e.g., re-transmission configuration information) in the control segment **230** (e.g., UE-specific information specific to UE **115-b**).

FIG. 3 illustrates an example of an environment **300** that supports dynamic group common physical control channel in accordance with aspects of the present disclosure. In some examples, environment **300** may implement aspects of wireless communication system **100**.

In the illustrated example, environment **300** may include control message **305**. As shown, control message **305** may include addressing random seed **310**, bitmap **315**, N control segments (e.g., first control segment **320-a** to Nth control segment **320-b**), and number of segments indicator **325**. In some examples, the control message **305** may include a group common physical control channel message. In some cases, control message **305** may be an example of control message **215** of FIGS. 2A and 2B. In some cases, the environment **300** provides a random hash-based solution that improves the efficiency of a control channel (e.g., group common physical downlink control channel (GC-PDCCH)) in addressing multiple UEs.

In some examples, control message **305** may be limited to some bit size. In some examples, control message **305** may be configured to include 96 bits (e.g., 96-bit payload). Among the total 96-bits, control message **305** may include 12-bits for addressing random seed **310**, $8 \times x$ -bits for the N control segments (e.g., 8-bits for each control segment from first control segment **320-a** to Nth control segment **320-b**), 3-bits for number of segments indicator **325**, and the remaining bits (e.g., L' bits) may be used for bitmap **315**. In an example, L' may be the leading part of a value L pre-configured or configured via control signaling (e.g., RRC signaling). In some cases, the value of x may be indicated by the number of segments indicator **325** to indicate how many control segments are carried in a particular control message **305**. In some cases, there may be x bits in bitmap **315** with a bit value of "1." In some cases, at least a portion of the number of bits in the total number of bits in bitmap **315** (e.g., the total number of bits equal to the remaining bits) may be indicated or pre-configured via radio resource control.

In some cases, control message **305** may be configured to carry a re-transmission indication for some number of UEs (e.g., based on cell radio network temporary identifier and the addressing random seed **310** for resource pool accessing). In some examples, to determine a corresponding control segment a UE determining a corresponding bit value "1" in the bitmap **315** may count how many "1" bit values precede its corresponding "1" bit value (e.g., determine m "1"s precede its corresponding bit value) and retrieve the (m+1)-th control segment of the N control segments that includes a control segment for the UE. For example, a first UE that applies its hash function to the addressing random seed that is mapped to a first "1" in the bitmap may process the first control segment, a second UE that applies its hash function to the addressing random seed that is mapped to a second "1" in the bitmap may process the second control segment, a third UE that applies its hash function to the addressing random seed that is mapped to a third "1" in the bitmap may process the third control segment, and so forth. In some examples, the network or base station may use a specific addressing random seed to map two or more UEs to the same position in the bit-map when the network or base station intends to send a common control segment to these two or more UEs. In some examples, control message **305** may be configured by a base station for M UEs (e.g., a group of M CG uplink UEs, a group of M randomly chosen CG uplink UEs) where N of the M UEs may be indicated for

re-transmission. In some examples, the base station may determine a random seed (e.g., addressing random seed **310**) that maximizes the number re-transmission UEs (e.g., UEs indicated for re-transmission, N UEs) assigned to a unique bit position in the bitmap **315** (e.g., a bit position of bitmap **315** uniquely associated with a single UE of the M UEs). In some examples, the base station may adaptively select a format (e.g., adaptively switch between formats) for control message **305** based on one or more conditions (e.g., channel conditions, etc.). For example, the control message **305** may be formatted as shown in FIGS. 2B, 3, 4, 5, and 6, and the base station **105-a** may transmit control signaling (e.g., a configuration message, RRC message, DCI, etc.) indicating which control message format is being applied for control message transmissions within the GC-PDCCH. The control signaling may also indicate the brute force solution and its variant described herein when a random hash function involves a modular operation over an integer $L > 1$, according to the set of UEs monitoring the GC-PDCCH. In some cases, the GC-PDCCH may carry a format flag in the control signaling to avoid the UE **115-a** from having to perform blind detection among these formats. Blind detection of the control message format may also be used. The UE **115-a** may process control message transmissions within the GC-PDCCH in accordance with the indicated control message format. In some cases, the base station may configure the group of M UEs in a star topology network, a star topology network over sidelink, a star topology network over NR sidelink, etc.

The techniques described herein may be when a physical control channel (e.g., sensitive to the total number of bits) is to be sent to some UEs that belong to a dynamic set (e.g., without nice indices assigned statically to each UE). In example, consider the opportunistic star topology network over NR side link (SL) where it is difficult for an opportunistic hub UE to assign nice indices to nearby peripheral UEs

In some examples, a hub UE may select a subgroup of peripheral UEs (e.g., a subgroup of one or more peripheral UEs, a subgroup of N UEs out of M UEs) to communicate with simultaneously over a relatively low-bit physical control channel (e.g., for improved coverage and robustness). For example, in some cases, the hub UE wants to communicate with just some of the peripheral UEs simultaneously, but not to other ones over a low-bit physical control channel (e.g., for coverage and robustness). In some cases, the hub UE may determine to poll one or more of the peripheral UEs (e.g., for low-bit reverse link control) over pre-assigned resources (e.g., orthogonal resources). In some cases, the hub UE may determine UE identifiers for each of the peripheral UEs, where each sidelink UE is preconfigured with one or more addressing hashing functions. In some cases, the sidelink hub UE may implement the communication with the selected peripheral UEs based on control message **305**.

In some examples, the addressing random seed **310** may be replaced by a hashing function index that indicates to a UE which hashing function to use. In some cases, a UE may switch (e.g., via a configuration message, a control message, signaling from a base station, pre-configuration, etc.) to using the indicated hashing function (e.g., a hashing function pre-configured in a table stored on the UE, indicated in a field of addressing random seed **310**). In some examples, the hashing function index may indicate a hashing function that extracts partial bits of a UE identifier as an input to the hashing function. In some cases, partial bits of a UE identifier may be used when the N re-transmission UEs may be

uniquely addressed among the group of M UEs by a portion of the UE identifiers (e.g., the first 10-bits of each UE identifier are unique from each other, or the last 10-bits of each UE identifier are unique from each other, etc.).

In some examples, a UE may be configured (e.g., by network, by base station, by pre-configuration) with a hashing function (e.g., random hashing function) to detect whether it is addressed by control message 305. In some cases, the inputs of the hashing function may include a random seed (e.g., addressing random seed 310), or a corresponding UE identifier, or a timing value, or any combination thereof.

In some example, a defined or default random seed may be used. For example, the control message 305 may carry the addressing indications and the N control segment 320 without the addressing random seed (e.g., addressing random seed 310). The base station may transmit control signaling (e.g., L1 signaling) to configure the UE with a default random number for use as an addressing random seed. In some examples, a base station may use a specific addressing random seed to map two or more UEs to the same bit position (e.g., the same bit value) in bitmap 315 when the base station intends to send a corresponding control segment to these two or more particular UEs.

FIG. 4 illustrates an example of an environment 400 that supports dynamic group common physical control channel in accordance with aspects of the present disclosure. In some examples, environment 400 may implement aspects of wireless communication system 100. In some examples, environment 400 may correspond to a bitmap including a compressed bitmap.

As illustrated, environment 400 may include control message 405, UE 115-c, and UE 115-d. In some cases, control message 405 may be an example of control message 215 of FIGS. 2A and 2B or control message 305 of FIG. 3. As shown, control message 405 may include addressing random seed 410, dynamic value 425, compressed bitmap 430, and control segment 420. In some examples, control segment 420 may include one or more control segments. In some examples, dynamic value 425 may include a modulo value. In some examples, the control message 405 may include a group common physical control channel message.

When computing a random hashing function involves a modular operation (e.g., over dynamic value 425 that is an integer $L > 1$), UE 115-c and UE 115-d may obtain dynamic value 425 (e.g., the integer value L) via a control message (e.g., dynamic value 425), or layer 1 messaging, or radio resource control in the context of a control message (e.g., control message 405, GC-PDCCH), or pre-configuration (e.g., system information block, over a side-link), online or dynamically indicated via the GC-PDCCH, or any combination thereof.

In some examples, because there may be a limited number of "1" bit values available in a bitmap of a given control message (e.g., control message 405), data encoding may be utilized to reduce the number of bits used in the given control message on bitmap description. In some cases, the data encoding may include Huffman-coding compression (e.g., G4/Modified-modified-Read), Lempel Ziv Welch (LZW) compression, arithmetic coding compression, etc. Accordingly, a bitmap (e.g., decompressed bitmap 415) may be compressed or encoded resulting in compressed bitmap 430. In some cases, the decompressed bitmap 415 may be compressed in conjunction with dynamic value 425 (e.g., an on-line dynamic value, a modulo value, etc.).

In the illustrated example, UE 115-c and UE 115-d may use dynamic value 425 and a decompression algorithm to

decompress the compressed bitmap 430 and reconstruct decompressed bitmap 415. In some cases, UE 115-c and UE 115-d may be preconfigured (e.g., by network, by base station) with the decompression algorithm. Thus, in some examples, UE 115-c and UE 115-d may receive, in control message 405, dynamic value 425 (e.g., a modulo value) and compressed bitmap 430, and then determine the decompressed bitmap 415 from the compressed bitmap 430 based on the dynamic value 425 and the decompression algorithm.

In the illustrated example, UE 115-c may compute (e.g., based on addressing random seed 410, etc.) the output of a hashing function associated with control message 405 and use the output as an index to determine a bit value in the decompressed bitmap 415 corresponding to UE 115-c is "0." Accordingly, UE 115-c may disregard the control message 405 based on the corresponding bit value being "0." In the illustrated example, UE 115-d may compute the output of the hashing function and use the output as an index to determine a bit value in decompressed bitmap 415 corresponding to UE 115-d is "1." Accordingly, UE 115-d may conduct a re-transmission according to information (e.g., re-transmission configuration information) in the control segment 420.

FIG. 5 illustrates an example of an environment 500 that supports dynamic group common physical control channel in accordance with aspects of the present disclosure. In some examples, environment 500 may implement aspects of wireless communication system 100. In some examples, environment 500 may correspond to a control message including a single seed and multiple bitmap indexes.

In the illustrated example, environment 500 may include control message 505. In some examples, the control message 505 may include a group common physical control channel message. In some cases, control message 505 may be an example of a control message of FIGS. 2A-4.

In some examples, a control message (e.g., control message 505) may provide one random seed value (e.g., addressing random seed 510) with multiple bitmap indices, where each bitmap index corresponds to a particular control segment. In the illustrated example, control message 505 may include addressing random seed 510 (e.g., a single random seed value), with first bitmap index 515 having a first value, first control segment 520, second bitmap index 525 having a second value, and second control segment 530 (e.g., multiple bitmap indices, where each bitmap index corresponds to a particular control segment).

In some examples, a UE may use one or more inputs (e.g., addressing random seed 510, or an identifier of the UE, or a timing value, or any combination thereof) to calculate an output of a hashing function. In some examples, the UE may determine the output of the hashing function and compare the output to an index value in the control message 505. Thus, the UE may compare the output of the hashing function to first bitmap index 515. If the UE determines that the output of the hashing function matches first bitmap index 515, the UE may retrieve first control segment 520. If the UE determines that the output of the hashing function does not match the first bitmap index 515, the UE may compare the output of the hashing function to second bitmap index 525. If the UE determines that the output of the hashing function matches second bitmap index 525, the UE may retrieve second control segment 530. If the UE determines that the output of the hashing function does not match first bitmap index 515 or the second bitmap index 525, the UE may discard control message 505.

In some cases, first index 515 may correspond to a first UE and second index 525 may correspond to a second UE

(e.g., as indicated by a configuration message, indicated by a corresponding bit value in a bitmap, etc.). Accordingly, if the first UE determines that the output of the hashing function matches first index **515**, the first UE may retrieve first control segment **520**. Otherwise, the first UE may discard control message **505**. In some examples, if the second UE determines that the output of the hashing function matches second index **525**, the second UE may retrieve second control segment **530**. Otherwise, the second UE may discard control message **505**.

FIG. 6 illustrates an example of an environment **600** that supports dynamic group common physical control channel in accordance with aspects of the present disclosure. In some examples, environment **600** may implement aspects of wireless communication system **100**. In some examples, environment **500** may correspond to a control message including a multiple seeds and multiple bitmap indexes.

In the illustrated example, environment **600** may include control message **605**. In some examples, the control message **605** may include a group common physical control channel message. In some cases, environment **600** may be an example of a control message of FIGS. 2A-5.

In some examples, a control message (e.g., control message **605**) may provide multiple random seed values with corresponding bitmap indices, where each bitmap index corresponds to a particular control segment. In the illustrated example, control message **605** may include first addressing random seed **610-a** (e.g., a first random seed value) corresponding to first bitmap index **615** having a first value and first control segment **620**, and second addressing random seed **610-b** (e.g., a second random seed value) corresponding to second bitmap index **625** having a second value and second control segment **630**.

In some cases, first index **615** may correspond to a first UE and second bitmap index **625** may correspond to a second UE (e.g., as indicated by a configuration message, indicated by a corresponding bit value in a bitmap, etc.).

In some examples, the first UE may use one or more inputs (e.g., first addressing random seed **610-a**, or an identifier of the first UE, or a timing value, or any combination thereof) to calculate an output of a hashing function. In some examples, the first UE may determine the output of the hashing function and compare the output to first bitmap index **615**. If the first UE determines that the output of the hashing function matches first index **615**, the first UE may retrieve first control segment **620** and perform a retransmission according to the information of first control segment **620** indicating how to conduct a re-transmission. Otherwise, the first UE may determine that the first control segment **620** is not addressed to the first UE, and may process the second addressing random seed **610-b**.

In some examples, the first UE may use one or more inputs (e.g., second addressing random seed **610-b**, or an identifier of the first UE, or a timing value, or any combination thereof) to calculate an output of a hashing function. In some examples, the first UE may determine the output of the hashing function and compare the output to second bitmap index **625**. If the first UE determines that the output of the hashing function matches second bitmap index **625**, the first UE may retrieve the second control segment **630** and perform a retransmission according to the information of second control segment **630** indicating how to conduct a re-transmission. Otherwise, the first UE may determine that the second control segment **630** is not addressed to the first UE, and may discard control message **605**.

FIG. 7 illustrates an example of an environment **700** that supports dynamic group common physical control channel

in accordance with aspects of the present disclosure. In some examples, environment **700** may implement aspects of wireless communication system **100**.

In some examples, environment **700** may include a first group common radio network temporary identifier (GC-RNTI) **705** and a second GC-RNTI **710** in a time frequency grid. As shown, first GC-RNTI **705** may include a first UE transmission **715**, and second GC-RNTI **710** may include a second UE transmission **720**. In some cases, first UE transmission **715** may be a transmission of a first UE and second UE transmission **720** may be a transmission of a second UE. In some cases, first UE transmission **715** and second UE transmission **720** may be transmission of the same UE.

In some examples, a UE may be provided a CG uplink on which to transmit data without asking for a dynamic grant. In some examples, after conducting a CG uplink transmission (e.g., first UE transmission **715**, second UE transmission **720**), a UE may monitor a PDCCCH for a pre-determined interval (e.g., based on initiating of a timer). When the UE receives a re-transmission indication (e.g., via a control message) before the timer expires, the UE may perform a re-transmission accordingly. Otherwise, the UE may assume its CG uplink transmission (e.g., first UE transmission **715**, second UE transmission **720**) is successful.

In some examples, one or more UEs may monitor the same control channel (e.g., control message via GC-PDCCCH), where the control channel carries multiple segments (e.g., control segments), and each segment includes a cell RNTI and a random seed (to access the CG resource pool) for a specific re-transmission UE. In some cases, a UE may be assigned a formula to compute a time-frequency dependent GC-RNTI (e.g., first GC-RNTI **705**, second GC-RNTI **710**) for re-transmissions (e.g., CG uplink UE re-transmissions). In some cases, the computed GC-RNTI may be computed instead of, or in addition to, a fixed GC-RNTI. In some cases, the GC-RNTI may be computed according to when and where a UE transmission occurs (e.g., based on frequency resources used, time resources used, etc.). The UE may use the computed time-frequency dependent GC-RNTI to determine whether a received control message is addressed to the UE. For example, the base station may scramble a CRC generated based on the control message and may transmit the control message with the scrambled CRC. The UE may generate a CRC from the received control message and descramble the received scrambled CRC for comparison looking for a match, indicating that the received control message is addressed to the UE. In some cases, a UE may be assigned a formula to compute a GC-RNTI via a control message (e.g., control message **605**, based on monitoring GC-PDCCCH, etc.).

Accordingly, a UE may perform a transmission (first UE transmission **715**, second UE transmission **720**) and then the UE may monitor the control channel (e.g., GC-PDCCCH). Based on the monitoring, the UE may determine that a control message indicates the UE is to perform a retransmission. In some cases, the control message may indicate to the UE a formula to compute a GC-RNTI (e.g., first GC-RNTI **705**, second GC-RNTI **710**). In some cases, the GC-RNTI may be specific to the UE. In some cases, the UE may use the GC-RNTI to determine control information for sending the re-transmission, to configure the UE on how to access the CG resource pool for re-transmission. Having a UE compute the GC-RNTI may ease the workload of a corresponding base station and provide increased processor and memory bandwidth to the base station to manage the workload on a group common physical control channel.

FIG. 8 shows a block diagram 800 of a device 805 that supports dynamic group common physical control channel in accordance with aspects of the present disclosure. The device 805 may be an example of aspects of a UE 115 as described herein. The device 805 may include a receiver 810, a communications manager 815, and a transmitter 820. The device 805 may also include a processor. Each of these components may be in communication with one another (e.g., via one or more buses).

The receiver 810 may receive information such as packets, user data, or control information associated with various information channels (e.g., control channels, data channels, and information related to dynamic group common physical control channel, etc.). Information may be passed on to other components of the device 805. The receiver 810 may be an example of aspects of the transceiver 1120 described with reference to FIG. 11. The receiver 810 may utilize a single antenna or a set of antennas.

The communications manager 815 may receive a configuration message indicating a group common control resource allocated to a set of UEs that includes the UE, identify a hashing function assigned to the UE for detecting control messaging communicated via the group common control resource that is addressed to the UE, receive, via the group common control resource, a control message indicating addressing data and a bitmap, and process the addressing data using the hashing function and the bitmap to determine applicability of the control message to the UE. The communications manager 815 may be an example of aspects of the communications manager 1110 described herein.

The communications manager 815, or its sub-components, may be implemented in hardware, code (e.g., software or firmware) executed by a processor, or any combination thereof. If implemented in code executed by a processor, the functions of the communications manager 815, or its sub-components may be executed by a general-purpose processor, a DSP, an application-specific integrated circuit (ASIC), an FPGA or other programmable logic device, discrete gate or transistor logic, discrete hardware components, or any combination thereof designed to perform the functions described in the present disclosure.

The communications manager 815, or its sub-components, may be physically located at various positions, including being distributed such that portions of functions are implemented at different physical locations by one or more physical components. In some examples, the communications manager 815, or its sub-components, may be a separate and distinct component in accordance with various aspects of the present disclosure. In some examples, the communications manager 815, or its sub-components, may be combined with one or more other hardware components, including but not limited to an input/output (I/O) component, a transceiver, a network server, another computing device, one or more other components described in the present disclosure, or a combination thereof in accordance with various aspects of the present disclosure.

The transmitter 820 may transmit signals generated by other components of the device 805. In some examples, the transmitter 820 may be collocated with a receiver 810 in a transceiver module. For example, the transmitter 820 may be an example of aspects of the transceiver 1120 described with reference to FIG. 11. The transmitter 820 may utilize a single antenna or a set of antennas.

FIG. 9 shows a block diagram 900 of a device 905 that supports dynamic group common physical control channel in accordance with aspects of the present disclosure. The device 905 may be an example of aspects of a device 805,

or a UE 115 as described herein. The device 905 may include a receiver 910, a communications manager 915, and a transmitter 940. The device 905 may also include a processor. Each of these components may be in communication with one another (e.g., via one or more buses).

The receiver 910 may receive information such as packets, user data, or control information associated with various information channels (e.g., control channels, data channels, and information related to dynamic group common physical control channel, etc.). Information may be passed on to other components of the device 905. The receiver 910 may be an example of aspects of the transceiver 1120 described with reference to FIG. 11. The receiver 910 may utilize a single antenna or a set of antennas.

The communications manager 915 may be an example of aspects of the communications manager 815 as described herein. The communications manager 915 may include a configuration manager 920, a computation manager 925, a control manager 930, and a process manager 935. The communications manager 915 may be an example of aspects of the communications manager 1110 described herein.

The configuration manager 920 may receive a configuration message indicating a group common control resource allocated to a set of UEs that includes the UE. The computation manager 925 may identify a hashing function assigned to the UE for detecting control messaging communicated via the group common control resource that is addressed to the UE. The control manager 930 may receive, via the group common control resource, a control message indicating addressing data and a bitmap. The process manager 935 may process the addressing data using the hashing function and the bitmap to determine applicability of the control message to the UE.

The transmitter 940 may transmit signals generated by other components of the device 905. In some examples, the transmitter 940 may be collocated with a receiver 910 in a transceiver module. For example, the transmitter 940 may be an example of aspects of the transceiver 1120 described with reference to FIG. 11. The transmitter 940 may utilize a single antenna or a set of antennas.

FIG. 10 shows a block diagram 1000 of a communications manager 1005 that supports dynamic group common physical control channel in accordance with aspects of the present disclosure. The communications manager 1005 may be an example of aspects of a communications manager 815, a communications manager 915, or a communications manager 1110 described herein. The communications manager 1005 may include a configuration manager 1010, a computation manager 1015, a control manager 1020, a process manager 1025, and a dynamic value manager 1030. Each of these modules may communicate, directly or indirectly, with one another (e.g., via one or more buses).

The configuration manager 1010 may receive a configuration message indicating a group common control resource allocated to a set of UEs that includes the UE. In some examples, the configuration manager 1010 may receive the configuration message including a hashing function index indicating the hashing function assigned to the UE from a set of different hashing functions. In some cases, the hashing function index indicates a function to extract one or more bits of an identifier of the UE to identify the hashing function assigned to the UE from the set of different hashing functions. In some cases, the configuration message indicates the hashing function.

The computation manager 1015 may identify a hashing function assigned to the UE for detecting control messaging communicated via the group common control resource that

is addressed to the UE. In some examples, the computation manager **1015** may receive control signaling indicating a formula assigned to the UE. In some examples, the computation manager **1015** may compute a group common radio network temporary identifier using the formula. In some examples, the computation manager **1015** may decode the control message based on the group common radio network temporary identifier.

The control manager **1020** may receive, via the group common control resource, a control message indicating addressing data and a bitmap. In some examples, the control manager **1020** may receive the control message indicating that the addressing data is a random seed for input to the hashing function. In some examples, the control manager **1020** may receive control signaling that indicates a length of the bitmap in the control message, where a hash output of the hashing function indicates a location of a bit in the bitmap based on the length of the bitmap. In some examples, the control manager **1020** may receive control signaling that indicates a number of control segments carried in the control message.

In some examples, the control manager **1020** may receive control signaling that indicates a modulo value to apply to a hash output of the hashing function to determine a bit in the bitmap, where the bit in the bitmap indicates applicability of the control message to the UE. In some examples, the control manager **1020** may receive control signaling that indicates a first format of a set of different formats for the control message, where the control message is processed based on the first format. In some examples, the control manager **1020** may receive the control message indicating the bitmap that includes a first bitmap index value corresponding to a first control segment of the control message and a second bitmap index value corresponding to a second control segment of the control message. In some examples, receiving the control message includes the addressing data that includes a first addressing seed corresponding to the first control segment and a second addressing seed corresponding to the second control segment.

In some examples, the control manager **1020** may process the first addressing seed using the hashing function and the first bitmap index value corresponding to the first control segment to determine applicability of the control message to the UE. In some examples, the control manager **1020** may process the second addressing seed using the hashing function and the second bitmap index value corresponding to the second control segment to determine applicability of the control message to the UE.

The process manager **1025** may process the addressing data using the hashing function and the bitmap to determine applicability of the control message to the UE. In some examples, the process manager **1025** may process the addressing data using the hashing function and the first bitmap index value to determine applicability of the control message to the UE. In some examples, the process manager **1025** may process the addressing data using the hashing function and the second bitmap index value to determine applicability of the control message to the UE.

In some examples, the process manager **1025** may determine a first bit in the bitmap based on a hash output of the hashing function. In some examples, the process manager **1025** may retrieve a location of a first control segment addressed to the UE of a set of control segments within the control message based on a number of bits in the bitmap preceding the first bit that a same value as the first bit. In some examples, the process manager **1025** may perform a

retransmission based on information indicated in the first control segment configuring the UE to perform the retransmission.

In some examples, the process manager **1025** may apply a current time, or at least a portion of an identifier of the UE, or the addressing data, or a cell radio network temporary identifier, or any combination thereof, as an input to the hashing function. In some examples, the process manager **1025** may determine an output of the hashing function based on the input.

The dynamic value manager **1030** may receive, in the control message, a modulo value and compressed bitmap data. In some examples, the dynamic value manager **1030** may determine the bitmap from the compressed bitmap data based on the modulo value and a decompression algorithm.

FIG. 11 shows a diagram of a system **1100** including a device **1105** that supports dynamic group common physical control channel in accordance with aspects of the present disclosure. The device **1105** may be an example of or include the components of device **805**, device **905**, or a UE **115** as described herein. The device **1105** may include components for bi-directional voice and data communications including components for transmitting and receiving communications, including a communications manager **1110**, an I/O controller **1115**, a transceiver **1120**, an antenna **1125**, memory **1130**, and a processor **1140**. These components may be in electronic communication via one or more buses (e.g., bus **1145**).

The communications manager **1110** may receive a configuration message indicating a group common control resource allocated to a set of UEs that includes the UE, identify a hashing function assigned to the UE for detecting control messaging communicated via the group common control resource that is addressed to the UE, receive, via the group common control resource, a control message indicating addressing data and a bitmap, and process the addressing data using the hashing function and the bitmap to determine applicability of the control message to the UE.

The I/O controller **1115** may manage input and output signals for the device **1105**. The I/O controller **1115** may also manage peripherals not integrated into the device **1105**. In some cases, the I/O controller **1115** may represent a physical connection or port to an external peripheral. In some cases, the I/O controller **1115** may utilize an operating system such as iOS®, ANDROID®, MS-DOS®, MS-WINDOWS®, OS/2®, UNIX®, LINUX®, or another known operating system. In other cases, the I/O controller **1115** may represent or interact with a modem, a keyboard, a mouse, a touchscreen, or a similar device. In some cases, the I/O controller **1115** may be implemented as part of a processor. In some cases, a user may interact with the device **1105** via the I/O controller **1115** or via hardware components controlled by the I/O controller **1115**.

The transceiver **1120** may communicate bi-directionally, via one or more antennas, wired, or wireless links as described herein. For example, the transceiver **1120** may represent a wireless transceiver and may communicate bi-directionally with another wireless transceiver. The transceiver **1120** may also include a modem to modulate the packets and provide the modulated packets to the antennas for transmission, and to demodulate packets received from the antennas.

In some cases, the wireless device may include a single antenna **1125**. However, in some cases the device may have more than one antenna **1125**, which may be capable of concurrently transmitting or receiving multiple wireless transmissions.

The memory 1130 may include RAM and ROM. The memory 1130 may store computer-readable, computer-executable code 1135 including instructions that, when executed, cause the processor to perform various functions described herein. In some cases, the memory 1130 may contain, among other things, a BIOS which may control basic hardware or software operation such as the interaction with peripheral components or devices.

The processor 1140 may include an intelligent hardware device, (e.g., a general-purpose processor, a DSP, a CPU, a microcontroller, an ASIC, an FPGA, a programmable logic device, a discrete gate or transistor logic component, a discrete hardware component, or any combination thereof). In some cases, the processor 1140 may be configured to operate a memory array using a memory controller. In other cases, a memory controller may be integrated into the processor 1140. The processor 1140 may be configured to execute computer-readable instructions stored in a memory (e.g., the memory 1130) to cause the device 1105 to perform various functions (e.g., functions or tasks supporting dynamic group common physical control channel).

The code 1135 may include instructions to implement aspects of the present disclosure, including instructions to support wireless communications. The code 1135 may be stored in a non-transitory computer-readable medium such as system memory or other type of memory. In some cases, the code 1135 may not be directly executable by the processor 1140 but may cause a computer (e.g., when compiled and executed) to perform functions described herein.

FIG. 12 shows a block diagram 1200 of a device 1205 that supports dynamic group common physical control channel in accordance with aspects of the present disclosure. The device 1205 may be an example of aspects of a base station 105 as described herein. The device 1205 may include a receiver 1210, a communications manager 1215, and a transmitter 1220. The device 1205 may also include a processor. Each of these components may be in communication with one another (e.g., via one or more buses).

The receiver 1210 may receive information such as packets, user data, or control information associated with various information channels (e.g., control channels, data channels, and information related to dynamic group common physical control channel, etc.). Information may be passed on to other components of the device 1205. The receiver 1210 may be an example of aspects of the transceiver 1520 described with reference to FIG. 15. The receiver 1210 may utilize a single antenna or a set of antennas.

The communications manager 1215 may transmit, to a UE, a configuration message indicating a group common control resource allocated to a set of UEs that includes the UE and indicating a hashing function assigned to the UE to configure the UE to determine applicability of control messaging communicated via the group common control resource that is addressed to the UE and transmit, to the UE via the group common control resource, a control message indicating addressing data and a bitmap. The communications manager 1215 may be an example of aspects of the communications manager 1510 described herein.

The communications manager 1215, or its sub-components, may be implemented in hardware, code (e.g., software or firmware) executed by a processor, or any combination thereof. If implemented in code executed by a processor, the functions of the communications manager 1215, or its sub-components may be executed by a general-purpose processor, a DSP, an application-specific integrated circuit (ASIC), an FPGA or other programmable logic device, discrete gate or transistor logic, discrete hardware compo-

nents, or any combination thereof designed to perform the functions described in the present disclosure.

The communications manager 1215, or its sub-components, may be physically located at various positions, including being distributed such that portions of functions are implemented at different physical locations by one or more physical components. In some examples, the communications manager 1215, or its sub-components, may be a separate and distinct component in accordance with various aspects of the present disclosure. In some examples, the communications manager 1215, or its sub-components, may be combined with one or more other hardware components, including but not limited to an input/output (I/O) component, a transceiver, a network server, another computing device, one or more other components described in the present disclosure, or a combination thereof in accordance with various aspects of the present disclosure.

The transmitter 1220 may transmit signals generated by other components of the device 1205. In some examples, the transmitter 1220 may be collocated with a receiver 1210 in a transceiver module. For example, the transmitter 1220 may be an example of aspects of the transceiver 1520 described with reference to FIG. 15. The transmitter 1220 may utilize a single antenna or a set of antennas.

FIG. 13 shows a block diagram 1300 of a device 1305 that supports dynamic group common physical control channel in accordance with aspects of the present disclosure. The device 1305 may be an example of aspects of a device 1205, or a base station 105 as described herein. The device 1305 may include a receiver 1310, a communications manager 1315, and a transmitter 1330. The device 1305 may also include a processor. Each of these components may be in communication with one another (e.g., via one or more buses).

The receiver 1310 may receive information such as packets, user data, or control information associated with various information channels (e.g., control channels, data channels, and information related to dynamic group common physical control channel, etc.). Information may be passed on to other components of the device 1305. The receiver 1310 may be an example of aspects of the transceiver 1520 described with reference to FIG. 15. The receiver 1310 may utilize a single antenna or a set of antennas.

The communications manager 1315 may be an example of aspects of the communications manager 1215 as described herein. The communications manager 1315 may include a format manager 1320 and a device manager 1325. The communications manager 1315 may be an example of aspects of the communications manager 1510 described herein.

The format manager 1320 may transmit, to a UE, a configuration message indicating a group common control resource allocated to a set of UEs that includes the UE and indicating a hashing function assigned to the UE to configure the UE to determine applicability of control messaging communicated via the group common control resource that is addressed to the UE.

The device manager 1325 may transmit, to the UE via the group common control resource, a control message indicating addressing data and a bitmap.

The transmitter 1330 may transmit signals generated by other components of the device 1305. In some examples, the transmitter 1330 may be collocated with a receiver 1310 in a transceiver module. For example, the transmitter 1330 may be an example of aspects of the transceiver 1520 described with reference to FIG. 15. The transmitter 1330 may utilize a single antenna or a set of antennas.

FIG. 14 shows a block diagram 1400 of a communications manager 1405 that supports dynamic group common physical control channel in accordance with aspects of the present disclosure. The communications manager 1405 may be an example of aspects of a communications manager 1215, a communications manager 1315, or a communications manager 1510 described herein. The communications manager 1405 may include a format manager 1410, a device manager 1415, a function manager 1420, and a bitmap manager 1425. Each of these modules may communicate, directly or indirectly, with one another (e.g., via one or more buses).

The format manager 1410 may transmit, to a UE, a configuration message indicating a group common control resource allocated to a set of UEs that includes the UE and indicating a hashing function assigned to the UE to configure the UE to determine applicability of control messaging communicated via the group common control resource that is addressed to the UE.

In some cases, a first control segment of a set of control segments within the control message configures the UE to perform a retransmission.

The device manager 1415 may transmit, to the UE via the group common control resource, a control message indicating addressing data and a bitmap. In some examples, the device manager 1415 may receive a retransmission from the UE based on information indicated in a first control segment that is addressed to the UE.

The function manager 1420 may transmit the configuration message including a hashing function index indicating the hashing function assigned to the UE from a set of different hashing functions. In some examples, the function manager 1420 may transmit the control message indicating that the addressing data is a random seed for input to the hashing function.

In some examples, the function manager 1420 may transmit control signaling that indicates a modulo value for the UE to apply to a hash output of the hashing function to configure the UE to determine a bit in the bitmap, where the bit in the bitmap indicates applicability of the control message to the UE. In some examples, the function manager 1420 may transmit control signaling that indicates a first format of a set of different formats for the control message to configure the UE to process the control message based on the first format.

In some examples, the function manager 1420 may transmit control signaling indicating a formula assigned, by the base station, to the UE to configure the UE to compute a group common radio network temporary identifier using the formula for decoding the control message. In some cases, the hashing function index indicates a function to extract one or more bits of an identifier of the UE to identify the hashing function assigned to the UE from the set of different hashing functions. In some cases, the configuration message indicates the hashing function.

The bitmap manager 1425 may transmit control signaling that indicates a length of the bitmap in the control message, where a hash output of the hashing function indicates a location of a bit in the bitmap based on the length of the bitmap. In some examples, the bitmap manager 1425 may transmit control signaling that indicates a number of control segments carried in the control message, where each bit in the bitmap having a first value corresponding to a respective control segment within the control message based on the number of control segments.

In some examples, the bitmap manager 1425 may transmit, in the control message, a modulo value and compressed bitmap data to configure the UE to determine the bitmap

from the compressed bitmap data based on the modulo value and a decompression algorithm. In some examples, the bitmap manager 1425 may transmit the control message indicating the bitmap that includes a first bitmap index value corresponding to a first control segment of the control message and a second bitmap index value corresponding to a second control segment of the control message.

In some examples, transmitting the control message including the addressing data that includes a first addressing seed corresponding to the first control segment and a second addressing seed corresponding to the second control segment.

FIG. 15 shows a diagram of a system 1500 including a device 1505 that supports dynamic group common physical control channel in accordance with aspects of the present disclosure. The device 1505 may be an example of or include the components of device 1205, device 1305, or a base station 105 as described herein. The device 1505 may include components for bi-directional voice and data communications including components for transmitting and receiving communications, including a communications manager 1510, a network communications manager 1515, a transceiver 1520, an antenna 1525, memory 1530, a processor 1540, and an inter-station communications manager 1545. These components may be in electronic communication via one or more buses (e.g., bus 1550).

The communications manager 1510 may transmit, to a UE, a configuration message indicating a group common control resource allocated to a set of UEs that includes the UE and indicating a hashing function assigned to the UE to configure the UE to determine applicability of control messaging communicated via the group common control resource that is addressed to the UE and transmit, to the UE via the group common control resource, a control message indicating addressing data and a bitmap.

The network communications manager 1515 may manage communications with the core network (e.g., via one or more wired backhaul links). For example, the network communications manager 1515 may manage the transfer of data communications for client devices, such as one or more UEs 115.

The transceiver 1520 may communicate bi-directionally, via one or more antennas, wired, or wireless links as described herein. For example, the transceiver 1520 may represent a wireless transceiver and may communicate bi-directionally with another wireless transceiver. The transceiver 1520 may also include a modem to modulate the packets and provide the modulated packets to the antennas for transmission, and to demodulate packets received from the antennas.

In some cases, the wireless device may include a single antenna 1525. However, in some cases the device may have more than one antenna 1525, which may be capable of concurrently transmitting or receiving multiple wireless transmissions.

The memory 1530 may include RAM, ROM, or a combination thereof. The memory 1530 may store computer-readable code 1535 including instructions that, when executed by a processor (e.g., the processor 1540) cause the device to perform various functions described herein. In some cases, the memory 1530 may contain, among other things, a BIOS which may control basic hardware or software operation such as the interaction with peripheral components or devices.

The processor 1540 may include an intelligent hardware device, (e.g., a general-purpose processor, a DSP, a CPU, a microcontroller, an ASIC, an FPGA, a programmable logic

device, a discrete gate or transistor logic component, a discrete hardware component, or any combination thereof). In some cases, the processor **1540** may be configured to operate a memory array using a memory controller. In some cases, a memory controller may be integrated into processor **1540**. The processor **1540** may be configured to execute computer-readable instructions stored in a memory (e.g., the memory **1530**) to cause the device **1505** to perform various functions (e.g., functions or tasks supporting dynamic group common physical control channel).

The inter-station communications manager **1545** may manage communications with other base station **105**, and may include a controller or scheduler for controlling communications with UEs **115** in cooperation with other base stations **105**. For example, the inter-station communications manager **1545** may coordinate scheduling for transmissions to UEs **115** for various interference mitigation techniques such as beamforming or joint transmission. In some examples, the inter-station communications manager **1545** may provide an X2 interface within an LTE/LTE-A wireless communication network technology to provide communication between base stations **105**.

The code **1535** may include instructions to implement aspects of the present disclosure, including instructions to support wireless communications. The code **1535** may be stored in a non-transitory computer-readable medium such as system memory or other type of memory. In some cases, the code **1535** may not be directly executable by the processor **1540** but may cause a computer (e.g., when compiled and executed) to perform functions described herein.

FIG. **16** shows a flowchart illustrating a method **1600** that supports dynamic group common physical control channel in accordance with aspects of the present disclosure. The operations of method **1600** may be implemented by a UE **115** or its components as described herein. For example, the operations of method **1600** may be performed by a communications manager as described with reference to FIGS. **8** through **11**. In some examples, a UE may execute a set of instructions to control the functional elements of the UE to perform the functions described herein. Additionally or alternatively, a UE may perform aspects of the functions described herein using special-purpose hardware.

At **1605**, the UE may receive a configuration message indicating a group common control resource allocated to a set of UEs that includes the UE. The operations of **1605** may be performed according to the methods described herein. In some examples, aspects of the operations of **1605** may be performed by a configuration manager as described with reference to FIGS. **8** through **11**.

At **1610**, the UE may identify a hashing function assigned to the UE for detecting control messaging communicated via the group common control resource that is addressed to the UE. The operations of **1610** may be performed according to the methods described herein. In some examples, aspects of the operations of **1610** may be performed by a computation manager as described with reference to FIGS. **8** through **11**.

At **1615**, the UE may receive, via the group common control resource, a control message indicating addressing data and a bitmap. The operations of **1615** may be performed according to the methods described herein. In some examples, aspects of the operations of **1615** may be performed by a control manager as described with reference to FIGS. **8** through **11**.

At **1620**, the UE may process the addressing data using the hashing function and the bitmap to determine applicability of the control message to the UE. The operations of **1620** may be performed according to the methods described

herein. In some examples, aspects of the operations of **1620** may be performed by a process manager as described with reference to FIGS. **8** through **11**.

FIG. **17** shows a flowchart illustrating a method **1700** that supports dynamic group common physical control channel in accordance with aspects of the present disclosure. The operations of method **1700** may be implemented by a UE **115** or its components as described herein. For example, the operations of method **1700** may be performed by a communications manager as described with reference to FIGS. **8** through **11**. In some examples, a UE may execute a set of instructions to control the functional elements of the UE to perform the functions described herein. Additionally or alternatively, a UE may perform aspects of the functions described herein using special-purpose hardware.

At **1705**, the UE may receive a configuration message indicating a group common control resource allocated to a set of UEs that includes the UE. The operations of **1705** may be performed according to the methods described herein. In some examples, aspects of the operations of **1705** may be performed by a configuration manager as described with reference to FIGS. **8** through **11**.

At **1710**, the UE may identify a hashing function assigned to the UE for detecting control messaging communicated via the group common control resource that is addressed to the UE. The operations of **1710** may be performed according to the methods described herein. In some examples, aspects of the operations of **1710** may be performed by a computation manager as described with reference to FIGS. **8** through **11**.

At **1715**, the UE may receive, via the group common control resource, a control message indicating addressing data and a bitmap. The operations of **1715** may be performed according to the methods described herein. In some examples, aspects of the operations of **1715** may be performed by a control manager as described with reference to FIGS. **8** through **11**.

At **1720**, the UE may process the addressing data using the hashing function and the bitmap to determine applicability of the control message to the UE. The operations of **1720** may be performed according to the methods described herein. In some examples, aspects of the operations of **1720** may be performed by a process manager as described with reference to FIGS. **8** through **11**.

At **1725**, the UE may receive the configuration message including a hashing function index indicating the hashing function assigned to the UE from a set of different hashing functions. The operations of **1725** may be performed according to the methods described herein. In some examples, aspects of the operations of **1725** may be performed by a configuration manager as described with reference to FIGS. **8** through **11**.

FIG. **18** shows a flowchart illustrating a method **1800** that supports dynamic group common physical control channel in accordance with aspects of the present disclosure. The operations of method **1800** may be implemented by a base station **105** or its components as described herein. For example, the operations of method **1800** may be performed by a communications manager as described with reference to FIGS. **12** through **15**. In some examples, a base station may execute a set of instructions to control the functional elements of the base station to perform the functions described herein. Additionally or alternatively, a base station may perform aspects of the functions described herein using special-purpose hardware.

At **1805**, the base station may transmit, to a UE, a configuration message indicating a group common control resource allocated to a set of UEs that includes the UE and

indicating a hashing function assigned to the UE to configure the UE to determine applicability of control messaging communicated via the group common control resource that is addressed to the UE. The operations of **1805** may be performed according to the methods described herein. In some examples, aspects of the operations of **1805** may be performed by a format manager as described with reference to FIGS. **12** through **15**.

At **1810**, the base station may transmit, to the UE via the group common control resource, a control message indicating addressing data and a bitmap. The operations of **1810** may be performed according to the methods described herein. In some examples, aspects of the operations of **1810** may be performed by a device manager as described with reference to FIGS. **12** through **15**.

FIG. **19** shows a flowchart illustrating a method **1900** that supports dynamic group common physical control channel in accordance with aspects of the present disclosure. The operations of method **1900** may be implemented by a base station **105** or its components as described herein. For example, the operations of method **1900** may be performed by a communications manager as described with reference to FIGS. **12** through **15**. In some examples, a base station may execute a set of instructions to control the functional elements of the base station to perform the functions described herein. Additionally or alternatively, a base station may perform aspects of the functions described herein using special-purpose hardware.

At **1905**, the base station may transmit, to a UE, a configuration message indicating a group common control resource allocated to a set of UEs that includes the UE and indicating a hashing function assigned to the UE to configure the UE to determine applicability of control messaging communicated via the group common control resource that is addressed to the UE. The operations of **1905** may be performed according to the methods described herein. In some examples, aspects of the operations of **1905** may be performed by a format manager as described with reference to FIGS. **12** through **15**.

At **1910**, the base station may transmit, to the UE via the group common control resource, a control message indicating addressing data and a bitmap. The operations of **1910** may be performed according to the methods described herein. In some examples, aspects of the operations of **1910** may be performed by a device manager as described with reference to FIGS. **12** through **15**.

At **1915**, the base station may transmit the configuration message including a hashing function index indicating the hashing function assigned to the UE from a set of different hashing functions. The operations of **1915** may be performed according to the methods described herein. In some examples, aspects of the operations of **1915** may be performed by a function manager as described with reference to FIGS. **12** through **15**.

It should be noted that the methods described herein describe possible implementations, and that the operations and the steps may be rearranged or otherwise modified and that other implementations are possible. Further, aspects from two or more of the methods may be combined.

The following provides an overview of aspects of the present disclosure:

Aspect 1: A method for wireless communication by a UE, comprising: receiving a configuration message indicating a group common control resource allocated to a plurality of UEs that includes the UE; identifying a hashing function assigned to the UE for detecting control messaging communicated via the group common control resource that is

addressed to the UE; receiving, via the group common control resource, a control message indicating addressing data and a bitmap; and processing the addressing data using the hashing function and the bitmap to determine applicability of the control message to the UE.

Aspect 2: The method of aspect 1, wherein identifying the hashing function comprises: receiving the configuration message comprising a hashing function index indicating the hashing function assigned to the UE from a plurality of different hashing functions.

Aspect 3: The method of aspect 2, wherein the hashing function index indicates a function to extract one or more bits of an identifier of the UE to identify the hashing function assigned to the UE from the plurality of different hashing functions.

Aspect 4: The method of any of aspects 1 through 3, wherein receiving the control message comprises: receiving the control message indicating that the addressing data is a random seed for input to the hashing function.

Aspect 5: The method of any of aspects 1 through 4, further comprising: receiving control signaling that indicates a length of the bitmap in the control message, wherein a hash output of the hashing function indicates a location of a bit in the bitmap based at least in part on the length of the bitmap.

Aspect 6: The method of any of aspects 1 through 5, further comprising: receiving control signaling that indicates a number of control segments carried in the control message.

Aspect 7: The method of any of aspects 1 through 6, further comprising: receiving control signaling that indicates a modulo value to apply to a hash output of the hashing function to determine a bit in the bitmap, wherein the bit in the bitmap indicates applicability of the control message to the UE.

Aspect 8: The method of any of aspects 1 through 7, further comprising: receiving control signaling that indicates a first format of a plurality of different formats for the control message, wherein the control message is processed based at least in part on the first format.

Aspect 9: The method of any of aspects 1 through 8, further comprising: receiving, in the control message, a modulo value and compressed bitmap data; and determining the bitmap from the compressed bitmap data based at least in part on the modulo value and a decompression algorithm.

Aspect 10: The method of any of aspects 1 through 9, further comprising: receiving control signaling indicating a formula assigned to the UE; computing a group common radio network temporary identifier using the formula; and decoding the control message based at least in part on the group common radio network temporary identifier.

Aspect 11: The method of any of aspects 1 through 10, wherein receiving the control message comprises: receiving the control message indicating the bitmap that includes a first bitmap index value corresponding to a first control segment of the control message and a second bitmap index value corresponding to a second control segment of the control message.

Aspect 12: The method of aspect 11, further comprising: processing the addressing data using the hashing function and the first bitmap index value to determine applicability of the control message to the UE.

Aspect 13: The method of any of aspects 11 through 12, further comprising: processing the addressing data using the hashing function and the second bitmap index value to determine applicability of the control message to the UE.

Aspect 14: The method of any of aspects 11 through 13, wherein receiving the control message comprises: receiving the control message comprising the addressing data that

comprises a first addressing seed corresponding to the first control segment and a second addressing seed corresponding to the second control segment.

Aspect 15: The method of aspect 14, further comprising: processing the first addressing seed using the hashing function and the first bitmap index value corresponding to the first control segment to determine applicability of the control message to the UE.

Aspect 16: The method of any of aspects 14 through 15, further comprising: processing the second addressing seed using the hashing function and the second bitmap index value corresponding to the second control segment to determine applicability of the control message to the UE.

Aspect 17: The method of any of aspects 1 through 16, further comprising: determining a first bit in the bitmap based at least in part on a hash output of the hashing function; and retrieving a location of a first control segment addressed to the UE of a plurality of control segments within the control message based at least in part on a number of bits in the bitmap preceding the first bit that a same value as the first bit.

Aspect 18: The method of aspect 17, further comprising: performing a retransmission based at least in part on information indicated in the first control segment configuring the UE to perform the retransmission.

Aspect 19: The method of any of aspects 1 through 18, further comprising: applying a current time, or at least a portion of an identifier of the UE, or the addressing data, or a cell radio network temporary identifier, or any combination thereof, as an input to the hashing function; and determining an output of the hashing function based at least in part on the input.

Aspect 20: The method of any of aspects 1 through 19, wherein the configuration message indicates the hashing function.

Aspect 21: A method for wireless communication by a base station, comprising: transmitting, to a UE, a configuration message indicating a group common control resource allocated to a plurality of UEs that includes the UE and indicating a hashing function assigned to the UE to configure the UE to determine applicability of control messaging communicated via the group common control resource that is addressed to the UE; and transmitting, to the UE via the group common control resource, a control message indicating addressing data and a bitmap.

Aspect 22: The method of aspect 21, further comprising: transmitting the configuration message comprising a hashing function index indicating the hashing function assigned to the UE from a plurality of different hashing functions.

Aspect 23: The method of aspect 22, wherein the hashing function index indicates a function to extract one or more bits of an identifier of the UE to identify the hashing function assigned to the UE from the plurality of different hashing functions.

Aspect 24: The method of any of aspects 21 through 23, wherein transmitting the control message comprises: transmitting the control message indicating that the addressing data is a random seed for input to the hashing function.

Aspect 25: The method of any of aspects 21 through 24, further comprising:

transmitting control signaling that indicates a length of the bitmap in the control message, wherein a hash output of the hashing function indicates a location of a bit in the bitmap based at least in part on the length of the bitmap.

Aspect 26: The method of any of aspects 21 through 25, further comprising: transmitting control signaling that indicates a number of control segments carried in the control

message, wherein each bit in the bitmap having a first value corresponding to a respective control segment within the control message based at least in part on the number of control segments.

Aspect 27: The method of any of aspects 21 through 26, further comprising: transmitting control signaling that indicates a modulo value for the UE to apply to a hash output of the hashing function to configure the UE to determine a bit in the bitmap, wherein the bit in the bitmap indicates applicability of the control message to the UE.

Aspect 28: The method of any of aspects 21 through 27, further comprising: transmitting control signaling that indicates a first format of a plurality of different formats for the control message to configure the UE to process the control message based at least in part on the first format.

Aspect 29: The method of any of aspects 21 through 28, further comprising: transmitting, in the control message, a modulo value and compressed bitmap data to configure the UE to determine the bitmap from the compressed bitmap data based at least in part on the modulo value and a decompression algorithm.

Aspect 30: The method of any of aspects 21 through 29, further comprising: transmitting control signaling indicating a formula assigned, by the base station, to the UE to configure the UE to compute a group common radio network temporary identifier using the formula for decoding the control message.

Aspect 31: The method of any of aspects 21 through 30, wherein transmitting the control message comprises: transmitting the control message indicating the bitmap that includes a first bitmap index value corresponding to a first control segment of the control message and a second bitmap index value corresponding to a second control segment of the control message.

Aspect 32: The method of aspect 31, wherein transmitting the control message comprises: transmitting the control message comprising the addressing data that comprises a first addressing seed corresponding to the first control segment and a second addressing seed corresponding to the second control segment.

Aspect 33: The method of any of aspects 21 through 32, wherein a first control segment of a plurality of control segments within the control message configures the UE to perform a retransmission.

Aspect 34: The method of any of aspects 21 through 33, further comprising: receiving a retransmission from the UE based at least in part on information indicated in a first control segment that is addressed to the UE.

Aspect 35: The method of any of aspects 21 through 34, wherein the configuration message indicates the hashing function.

Aspect 36: An apparatus for wireless communication by a UE, comprising a processor; memory coupled with the processor; and instructions stored in the memory and executable by the processor to cause the apparatus to perform a method of any of aspects 1 through 20.

Aspect 37: An apparatus for wireless communication by a UE, comprising at least one means for performing a method of any of aspects 1 through 20.

Aspect 38: A non-transitory computer-readable medium storing code for wireless communication by a UE, the code comprising instructions executable by a processor to perform a method of any of aspects 1 through 20.

Aspect 39: An apparatus for wireless communication by a base station, comprising a processor; memory coupled with the processor; and instructions stored in the memory

and executable by the processor to cause the apparatus to perform a method of any of aspects 21 through 35.

Aspect 40: An apparatus for wireless communication by a base station, comprising at least one means for performing a method of any of aspects 21 through 35.

Aspect 41: A non-transitory computer-readable medium storing code for wireless communication by a base station, the code comprising instructions executable by a processor to perform a method of any of aspects 21 through 35.

Although aspects of an LTE, LTE-A, LTE-A Pro, or NR system may be described for purposes of example, and LTE, LTE-A, LTE-A Pro, or NR terminology may be used in much of the description, the techniques described herein are applicable beyond LTE, LTE-A, LTE-A Pro, or NR networks. For example, the described techniques may be applicable to various other wireless communications systems such as Ultra Mobile Broadband (UMB), Institute of Electrical and Electronics Engineers (IEEE) 802.11 (Wi-Fi), IEEE 802.16 (WiMAX), IEEE 802.20, Flash-OFDM, as well as other systems and radio technologies not explicitly mentioned herein.

Information and signals described herein may be represented using any of a variety of different technologies and techniques. For example, data, instructions, commands, information, signals, bits, symbols, and chips that may be referenced throughout the description may be represented by voltages, currents, electromagnetic waves, magnetic fields or particles, optical fields or particles, or any combination thereof.

The various illustrative blocks and components described in connection with the disclosure herein may be implemented or performed with a general-purpose processor, a DSP, an ASIC, a CPU, an FPGA or other programmable logic device, discrete gate or transistor logic, discrete hardware components, or any combination thereof designed to perform the functions described herein. A general-purpose processor may be a microprocessor, but in the alternative, the processor may be any processor, controller, microcontroller, or state machine. A processor may also be implemented as a combination of computing devices (e.g., a combination of a DSP and a microprocessor, multiple microprocessors, one or more microprocessors in conjunction with a DSP core, or any other such configuration).

The functions described herein may be implemented in hardware, software executed by a processor, firmware, or any combination thereof. If implemented in software executed by a processor, the functions may be stored on or transmitted over as one or more instructions or code on a computer-readable medium. Other examples and implementations are within the scope of the disclosure and appended claims. For example, due to the nature of software, functions described herein may be implemented using software executed by a processor, hardware, firmware, hardwiring, or combinations of any of these. Features implementing functions may also be physically located at various positions, including being distributed such that portions of functions are implemented at different physical locations.

Computer-readable media includes both non-transitory computer storage media and communication media including any medium that facilitates transfer of a computer program from one place to another. A non-transitory storage medium may be any available medium that may be accessed by a general-purpose or special-purpose computer. By way of example, and not limitation, non-transitory computer-readable media may include random-access memory (RAM), read-only memory (ROM), electrically erasable programmable ROM (EEPROM), flash memory, compact

disk (CD) ROM or other optical disk storage, magnetic disk storage or other magnetic storage devices, or any other non-transitory medium that may be used to carry or store desired program code means in the form of instructions or data structures and that may be accessed by a general-purpose or special-purpose computer, or a general-purpose or special-purpose processor. Also, any connection is properly termed a computer-readable medium. For example, if the software is transmitted from a website, server, or other remote source using a coaxial cable, fiber optic cable, twisted pair, digital subscriber line (DSL), or wireless technologies such as infrared, radio, and microwave, then the coaxial cable, fiber optic cable, twisted pair, DSL, or wireless technologies such as infrared, radio, and microwave are included in the definition of computer-readable medium. Disk and disc, as used herein, include CD, laser disc, optical disc, digital versatile disc (DVD), floppy disk and Blu-ray disc where disks usually reproduce data magnetically, while discs reproduce data optically with lasers. Combinations of the above are also included within the scope of computer-readable media.

As used herein, including in the claims, “or” as used in a list of items (e.g., a list of items prefaced by a phrase such as “at least one of” or “one or more of”) indicates an inclusive list such that, for example, a list of at least one of A, B, or C means A or B or C or AB or AC or BC or ABC (i.e., A and B and C). Also, as used herein, the phrase “based on” shall not be construed as a reference to a closed set of conditions. For example, an example step that is described as “based on condition A” may be based on both a condition A and a condition B without departing from the scope of the present disclosure. In other words, as used herein, the phrase “based on” shall be construed in the same manner as the phrase “based at least in part on.”

In the appended figures, similar components or features may have the same reference label. Further, various components of the same type may be distinguished by following the reference label by a dash and a second label that distinguishes among the similar components. If just the first reference label is used in the specification, the description is applicable to any one of the similar components having the same first reference label irrespective of the second reference label, or other subsequent reference label.

The description set forth herein, in connection with the appended drawings, describes example configurations and does not represent all the examples that may be implemented or that are within the scope of the claims. The term “example” used herein means “serving as an example, instance, or illustration,” and not “preferred” or “advantageous over other examples.” The detailed description includes specific details for the purpose of providing an understanding of the described techniques. These techniques, however, may be practiced without these specific details. In some instances, known structures and devices are shown in block diagram form in order to avoid obscuring the concepts of the described examples.

The description herein is provided to enable a person having ordinary skill in the art to make or use the disclosure. Various modifications to the disclosure will be apparent to a person having ordinary skill in the art, and the generic principles defined herein may be applied to other variations without departing from the scope of the disclosure. Thus, the disclosure is not limited to the examples and designs described herein, but is to be accorded the broadest scope consistent with the principles and novel features disclosed herein.

41

What is claimed is:

1. An apparatus for wireless communication by a user equipment (UE), comprising:

one or more processors; and

one or more memories coupled with the one or more processors and storing instructions that are executable by the one or more processors to cause the apparatus to: receive a configuration message indicating a group common control resource allocated to a plurality of UEs that includes the UE;

identify a hashing function assigned to the UE for detecting control messaging communicated via the group common control resource that is addressed to the UE;

receive, via the group common control resource, a control message comprising an addressing data field that comprises addressing data for input into the hashing function and a bitmap that comprises a plurality of bits corresponding to the plurality of UEs, the addressing data field being separate from the bitmap, wherein the plurality of bits of the bitmap differs from the addressing data of the addressing data field; and

process the addressing data using the hashing function and the bitmap to determine applicability of the control message to the UE, the addressing data being input into the hashing function to obtain a hash output indicating an index of a respective bit of the plurality of bits of the bitmap, wherein the applicability of the control message to the UE is determined based at least in part on a value of the respective bit indexed by the hash output.

2. The apparatus of claim **1**, wherein the instructions to identify the hashing function are executable by the one or more processors to cause the apparatus to:

receive the configuration message comprising a hashing function index indicating the hashing function assigned to the UE from a plurality of different hashing functions.

3. The apparatus of claim **2**, wherein the hashing function index indicates a function to extract one or more bits of an identifier of the UE to identify the hashing function assigned to the UE from the plurality of different hashing functions.

4. The apparatus of claim **1**, wherein the instructions to receive the control message are executable by the one or more processors to cause the apparatus to:

receive the control message indicating that the addressing data field comprises the addressing data that is a random seed for the input to the hashing function.

5. The apparatus of claim **1**, wherein the instructions are further executable by the one or more processors to cause the apparatus to:

receive control signaling that indicates a length of the bitmap in the control message, wherein the index indicated via the hash output of the hashing function is a location of a bit in the bitmap from the plurality of bits of the bitmap based at least in part on the length of the bitmap.

6. The apparatus of claim **1**, wherein the instructions are further executable by the one or more processors to cause the apparatus to:

receive control signaling that indicates a number of control segments carried in the control message.

7. The apparatus of claim **1**, wherein the instructions are further executable by the one or more processors to cause the apparatus to:

42

receive control signaling that indicates a modulo value to apply to the hash output of the hashing function to determine a bit in the bitmap from the plurality of bits of the bitmap, wherein the bit in the bitmap indicates the applicability of the control message to the UE.

8. The apparatus of claim **1**, wherein the instructions are further executable by the one or more processors to cause the apparatus to:

receive control signaling that indicates a first format of a plurality of different formats for the control message, wherein the control message is processed based at least in part on the first format.

9. The apparatus of claim **1**, wherein the instructions are further executable by the one or more processors to cause the apparatus to:

receive, in the control message, a modulo value and compressed bitmap data; and determine the bitmap from the compressed bitmap data based at least in part on the modulo value and a decompression algorithm.

10. The apparatus of claim **1**, wherein the instructions are further executable by the one or more processors to cause the apparatus to:

receive control signaling indicating a formula assigned to the UE;

compute a group common radio network temporary identifier using the formula; and

decode the control message based at least in part on the group common radio network temporary identifier.

11. The apparatus of claim **1**, wherein the instructions to receive the control message are executable by the one or more processors to cause the apparatus to:

receive the control message indicating the bitmap that includes a first bitmap index value corresponding to a first control segment of the control message and a second bitmap index value corresponding to a second control segment of the control message.

12. The apparatus of claim **11**, wherein the instructions are further executable by the one or more processors to cause the apparatus to:

process the addressing data using the hashing function and the first bitmap index value to determine the applicability of the control message to the UE.

13. The apparatus of claim **11**, wherein the instructions are further executable by the one or more processors to cause the apparatus to:

process the addressing data using the hashing function and the second bitmap index value to determine the applicability of the control message to the UE.

14. The apparatus of claim **11**, wherein the instructions to receive the control message are executable by the one or more processors to cause the apparatus to:

receive the control message comprising the addressing data field that comprises a first addressing seed corresponding to the first control segment and a second addressing seed corresponding to the second control segment.

15. The apparatus of claim **14**, wherein the instructions are further executable by the one or more processors to cause the apparatus to:

process the first addressing seed using the hashing function and the first bitmap index value corresponding to the first control segment to determine the applicability of the control message to the UE.

16. The apparatus of claim **14**, wherein the instructions are further executable by the one or more processors to cause the apparatus to:

43

process the second addressing seed using the hashing function and the second bitmap index value corresponding to the second control segment to determine the applicability of the control message to the UE.

17. The apparatus of claim 1, wherein the instructions are further executable by the one or more processors to cause the apparatus to:

determine a first bit in the bitmap from the plurality of bits of the bitmap based at least in part on the hash output of the hashing function; and

retrieve a location of a first control segment addressed to the UE of a plurality of control segments within the control message based at least in part on a number of bits in the bitmap preceding the first bit that is a same value as the first bit.

18. The apparatus of claim 17, wherein the instructions are further executable by the one or more processors to cause the apparatus to:

perform a retransmission based at least in part on information indicated in the first control segment configuring the UE to perform the retransmission.

19. The apparatus of claim 1, wherein the instructions are further executable by the one or more processors to cause the apparatus to:

apply a current time, or at least a portion of an identifier of the UE, or the addressing data, or a cell radio network temporary identifier, or any combination thereof, as the input to the hashing function; and determine an output of the hashing function based at least in part on the input.

20. The apparatus of claim 1, wherein the configuration message indicates the hashing function.

21. A method for wireless communication by a user equipment (UE), comprising:

receiving a configuration message indicating a group common control resource allocated to a plurality of UEs that includes the UE;

identifying a hashing function assigned to the UE for detecting control messaging communicated via the group common control resource that is addressed to the UE;

receiving, via the group common control resource, a control message comprising an addressing data field that comprises addressing data for input into the hashing function and a bitmap that comprises a plurality of bits corresponding to the plurality of UEs, the addressing data field being separate from the bitmap, wherein the plurality of bits of the bitmap differs from the addressing data of the addressing data field; and

processing the addressing data using the hashing function and the bitmap to determine applicability of the control message to the UE, the addressing data being input into the hashing function to obtain a hash output indicating an index of a respective bit of the plurality of bits of the bitmap, wherein the applicability of the control message to the UE is determined based at least in part on a value of the respective bit indexed by the hash output.

22. The method of claim 21, wherein identifying the hashing function comprises:

receiving the configuration message comprising a hashing function index indicating the hashing function assigned to the UE from a plurality of different hashing functions.

23. The method of claim 22, wherein the hashing function index indicates a function to extract one or more bits of an identifier of the UE to identify the hashing function assigned to the UE from the plurality of different hashing functions.

44

24. The method of claim 21, wherein receiving the control message comprises:

receiving the control message indicating that the addressing data field comprises the addressing data that is a random seed for the input to the hashing function.

25. The method of claim 21, further comprising: receiving control signaling that indicates a length of the bitmap in the control message, wherein the index indicated via the hash output of the hashing function is a location of a bit in the bitmap from the plurality of bits of the bitmap based at least in part on the length of the bitmap.

26. The method of claim 21, further comprising: receiving control signaling that indicates a number of control segments carried in the control message.

27. The method of claim 21, further comprising: receiving control signaling that indicates a modulo value to apply to the hash output of the hashing function to determine a bit in the bitmap from the plurality of bits of the bitmap, wherein the bit in the bitmap indicates the applicability of the control message to the UE.

28. The method of claim 21, further comprising: receiving control signaling that indicates a first format of a plurality of different formats for the control message, wherein the control message is processed based at least in part on the first format.

29. An apparatus for wireless communication by a user equipment (UE), comprising:

means for receiving a configuration message indicating a group common control resource allocated to a plurality of UEs that includes the UE;

means for identifying a hashing function assigned to the UE for detecting control messaging communicated via the group common control resource that is addressed to the UE;

means for receiving, via the group common control resource, a control message comprising an addressing data field that comprises addressing data for input into the hashing function and a bitmap that comprises a plurality of bits corresponding to the plurality of UEs, the addressing data field being separate from the bitmap, wherein the plurality of bits of the bitmap differs from the addressing data of the addressing data field; and

means for processing the addressing data using the hashing function and the bitmap to determine applicability of the control message to the UE, the addressing data being input into the hashing function to obtain a hash output indicating an index of a respective bit of the plurality of bits of the bitmap, wherein the applicability of the control message to the UE is determined based at least in part on a value of the respective bit indexed by the hash output.

30. A non-transitory computer-readable medium storing code for wireless communication by a user equipment (UE), the code comprising instructions executable by one or more processors to:

receive a configuration message indicating a group common control resource allocated to a plurality of UEs that includes the UE;

identify a hashing function assigned to the UE for detecting control messaging communicated via the group common control resource that is addressed to the UE;

receive, via the group common control resource, a control message comprising an addressing data field that comprises addressing data for input into the hashing function and a bitmap that comprises a plurality of bits

corresponding to the plurality of UEs, the addressing data field being separate from the bitmap, wherein the plurality of bits of the bitmap differs from the addressing data of the addressing data field; and
process the addressing data using the hashing function 5
and the bitmap to determine applicability of the control message to the UE, the addressing data being input into the hashing function to obtain a hash output indicating an index of a respective bit of the plurality of bits of the bitmap, wherein the applicability of the control mes- 10
sage to the UE is determined based at least in part on a value of the respective bit indexed by the hash output.

* * * * *