

(19)  
(12)

(KR)  
(A)

(51) 。 Int. Cl. <sup>7</sup>  
B21B 45/00

(11)  
(43)

2001 - 0058172  
2001 07 05

(21) 10 - 1999 - 0061680  
(22) 1999 12 24

(71)

1

(72)

5

5

(74)

:

(54)

(12) (14) (20) (10) (20) (10)  
 , (30); , 가 (30) 2 (40); (10) (12b) (P) (12a)  
 1 , 가 1 (30) 2 (40); (10) (P)

1

2

3

4

\*

\*

1....

10....

20....

12....

14....

30,40....

1,2

32,42....

34....

52....

54....

58....

60....

(scarfing machine) (finishing Mill) 가

가

1

, 1 (130) (120) (100)  
 , (132) , (134) (140a)  
 (100) (140b) (100)  
 , (S) .

, (110) 가 가 1 (100) , (pattern),  
 (100) , (110)

, (100) (110) 가 가 (110)  
 (110) , 가 가 .

, (110) 가 ,  
 (110) 가 ,  
 , (110) (100) ,

(P) ,

1 ; ,

1 2 ;

(P)

, 가

2

, 3

, 4  
 (1) 1,2 (30)(40)  
 (10) (12) (30) (P) (20)

(30) , (20) (10) (12b) 1  
(32)(42)가 가 1 (30) 2 (40) (10) (d), (S) (12a)

1,2 (30)(40) (32)(42) , 4 - 6 mm, 5mm (d  
) , 55 - 65 °, 60 ° (S) , 47 - 52 mm, 50mm (W) , (L)

1 (30) (20) (10) (34)  
2 (40) (10) (52)  
(56) □ (54) (44)

(54) (52) (56) (52) 가 (52)  
(54) 가 (58) , (54)  
(60) (60a)가 (62) (64) (54) 가

2 4 , (10) (scarfing)  
(10) (12)  
(1)

2 3 (10) (34) (20)  
0) 1 (10) (12) , 1 (30) (P) (2)  
가 , (20) 10mm , 1 (30)

□ (10) (52) (56)  
(54)가 가 , (54)  
2 2 (40) (44) 가 ,  
(44) (34) 2 (40)

(20) (10) (12b) (12a)  
1,2 (30)(40) (32)(42) , 4 ,  
1,2 (30)(40) (32)(42)  
(32)(42) (30)(40)  
(10)가

(10) (30)(40) (32)(42) (d), (S), (W) (L)  
 6mm (32)(42) , 4 - 6 mm, 5mm (d) , 2 - 5mm  
 (12) , Fe<sub>2</sub>O<sub>3</sub>, Fe<sub>3</sub>O<sub>2</sub> , FeO , 4mm  
 (32)(42) 5mm 가 가  
 65° (32)(42) 55 - 65° , 60° , 55°  
 47mm (32)(42) (W) , (L) 47 - 52 mm, 50mm  
 52mm  
 (54) (52) (56) (58) 가  
 (52)(54) , 2 (40)  
 (58)  
 (64) 2 (40) (10) 가 (54)  
 (62) (60) (60a)  
 (60) , 2 (40) (54)  
 (60) (54)가  
 1,2 (52)(54) (12) (10) (10) 가 (P)  
 )

가

가

(57)

1.

(20) (10) (12) (30)  
 (P) ,

(20) (10) (12b) 1  
 (30); ,

1 (30) 2 (40); (10) (P) (12a) ,  
가

2.

1 , 1,2 (30)(40) (d), (S), (W) (L)  
(32)(42)가

3.

2 , 1,2 (30)(40) (32)(42) 4 - 6 mm (d), 55 - 65 °  
(S), 47 - 52 mm (W) (L)

4.

1 , 1 (30) (20) (10) (34) ( ,  
2 (40) (10) (54) ( )  
52) (56) □ (54)  
(44)

5.

4 , (54) (52) (56) (52) 가 (54)  
(52) (54) 가 (58) , (54)  
(60) (60a)가 (62) (64) (54) 가

1

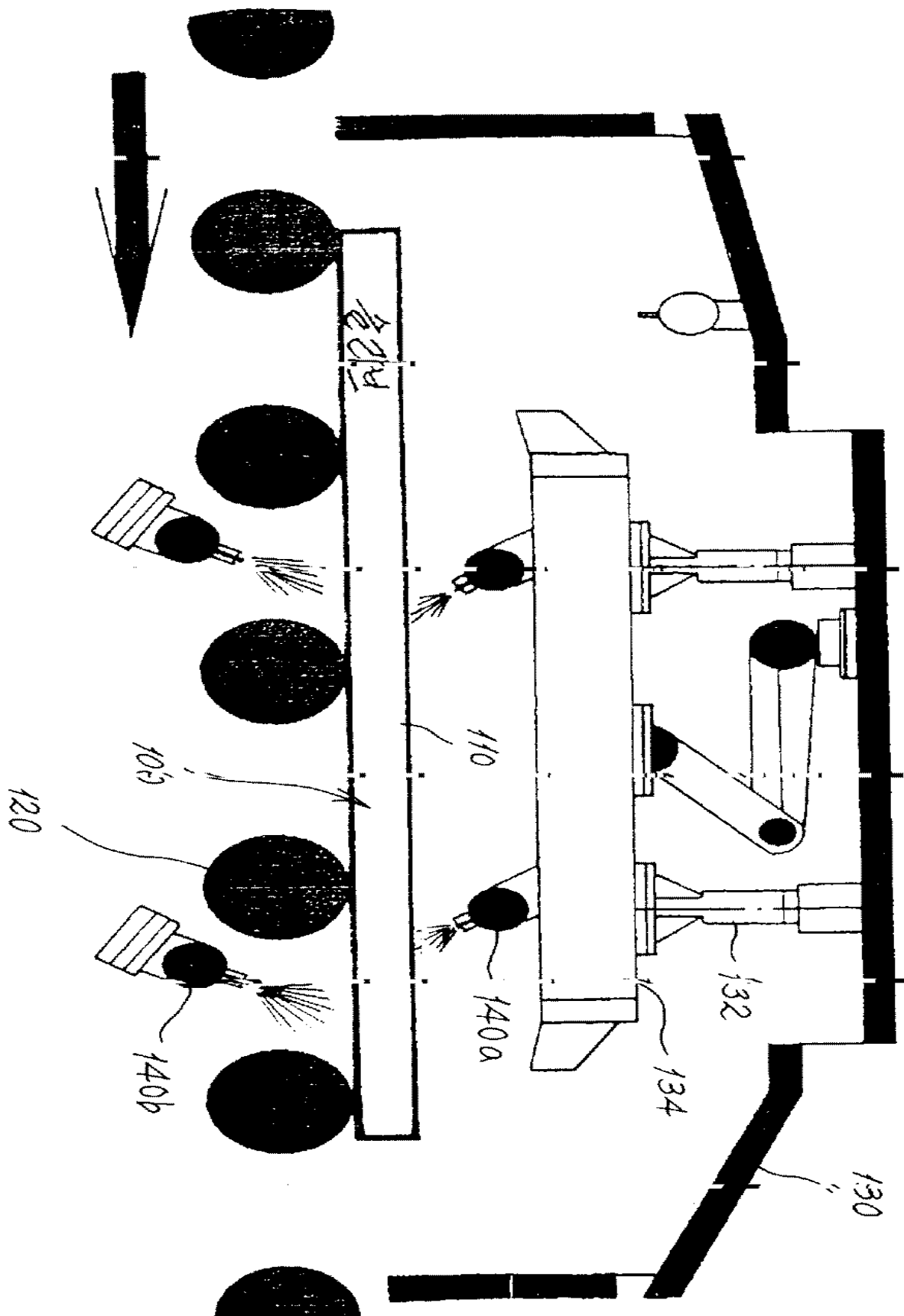

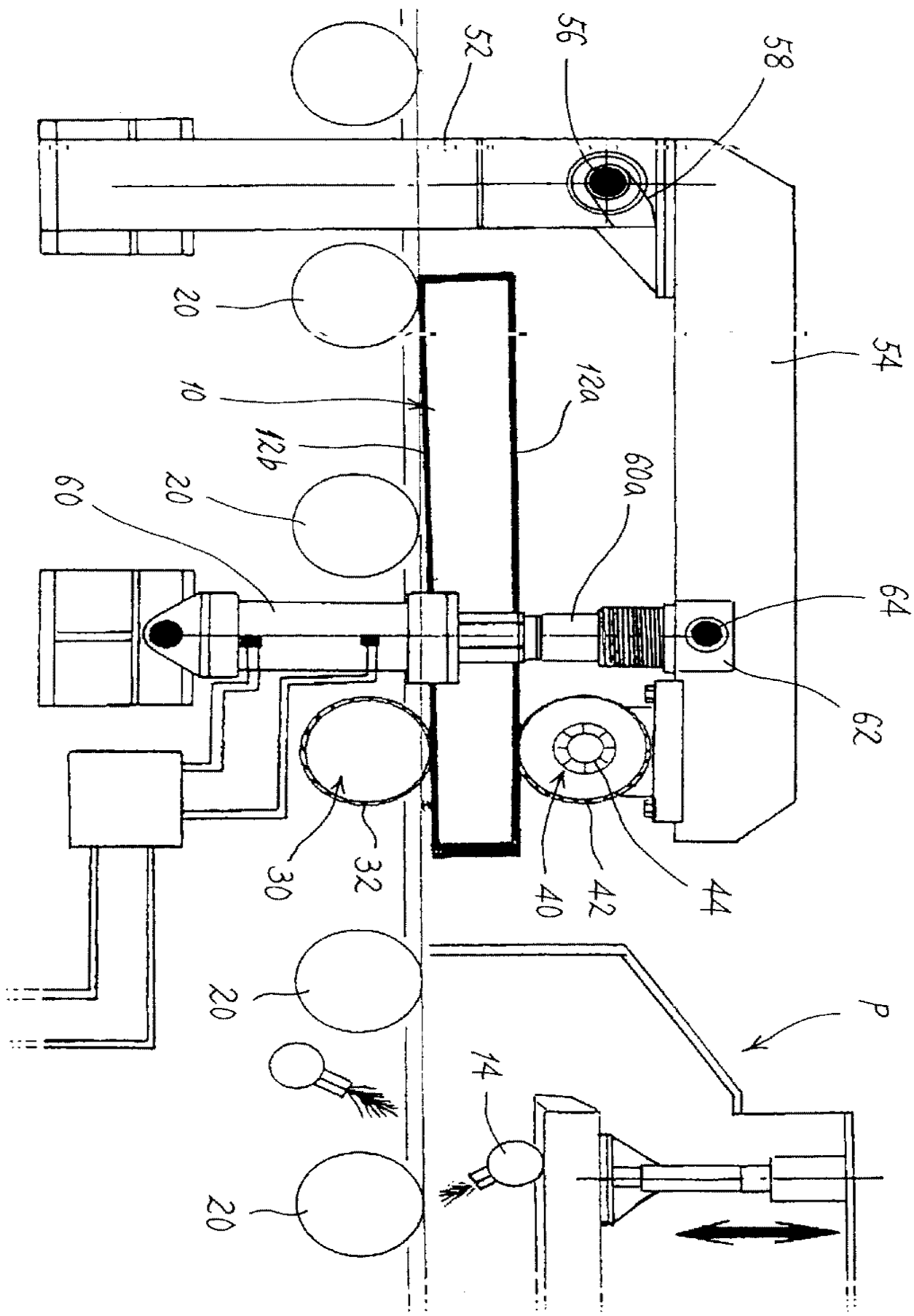

3

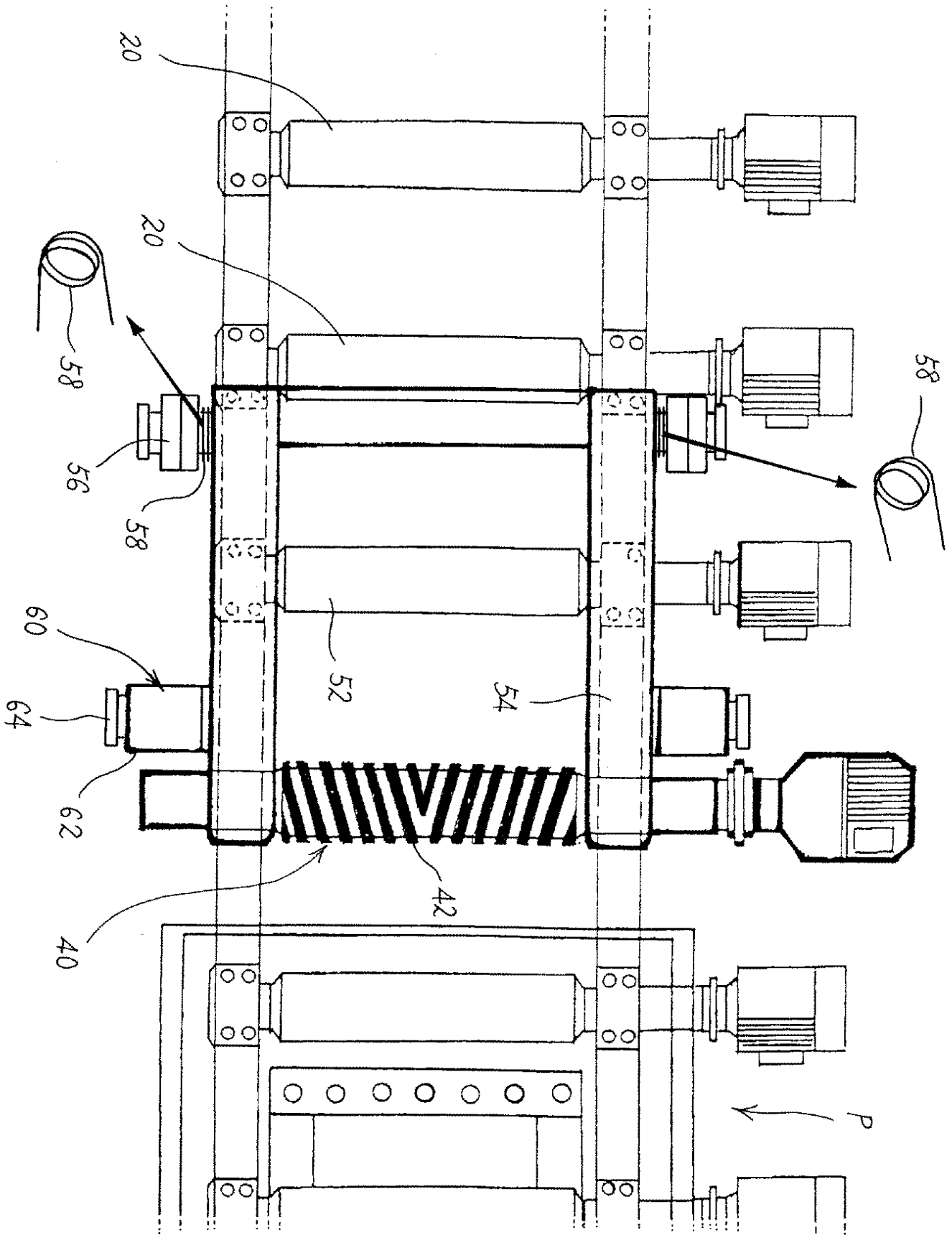

4

