

(19) World Intellectual Property Organization
International Bureau



(43) International Publication Date
23 December 2010 (23.12.2010)

PCT

(10) International Publication Number
WO 2010/146060 A1

(51) International Patent Classification:

A23K 1/16 (2006.01) A23K 1/18 (2006.01)
A23K 1/175 (2006.01)

(21) International Application Number:

PCT/EP2010/058405

(22) International Filing Date:

15 June 2010 (15.06.2010)

(25) Filing Language:

English

(26) Publication Language:

English

(30) Priority Data:

61/218,765 19 June 2009 (19.06.2009) US
09305580.4 19 June 2009 (19.06.2009) EP

(71) Applicant (for all designated States except US): **SPECIALITES PET FOOD** [FR/FR]; 6, Place de la Madeleine, F-75008 Paris (FR).

(72) Inventors; and

(75) Inventors/Applicants (for US only): **BRAMOULLE, Loïc** [FR/FR]; 5, route de Ludré St COLOMBIER, F-56370 Sarzeau (FR). **GUILLER, Isabelle** [FR/FR]; 34, rue de Belle Croix, F-56370 Le Tour Du Parc (FR). **RU-AUD, Julien** [FR/FR]; 13, avenue de Gournava, F-56140 Pleucadeuc (FR).

(74) Agent: **WARCOIN, Jacques**; Cabinet Regimbeau, 20, rue de Chazelles, F-75847 Paris Cedex 17 (FR).

(81) Designated States (unless otherwise indicated, for every

kind of national protection available): AE, AG, AL, AM, AO, AT, AU, AZ, BA, BB, BG, BH, BR, BW, BY, BZ, CA, CH, CL, CN, CO, CR, CU, CZ, DE, DK, DM, DO, DZ, EC, EE, EG, ES, FI, GB, GD, GE, GH, GM, GT, HN, HR, HU, ID, IL, IN, IS, JP, KE, KG, KM, KN, KP, KR, KZ, LA, LC, LK, LR, LS, LT, LU, LY, MA, MD, ME, MG, MK, MN, MW, MX, MY, MZ, NA, NG, NI, NO, NZ, OM, PE, PG, PH, PL, PT, RO, RS, RU, SC, SD, SE, SG, SK, SL, SM, ST, SV, SY, TH, TJ, TM, TN, TR, TT, TZ, UA, UG, US, UZ, VC, VN, ZA, ZM, ZW.

(84) Designated States (unless otherwise indicated, for every

kind of regional protection available): ARIPO (BW, GH, GM, KE, LR, LS, MW, MZ, NA, SD, SL, SZ, TZ, UG, ZM, ZW), Eurasian (AM, AZ, BY, KG, KZ, MD, RU, TJ, TM), European (AL, AT, BE, BG, CH, CY, CZ, DE, DK, EE, ES, FI, FR, GB, GR, HR, HU, IE, IS, IT, LT, LU, LV, MC, MK, MT, NL, NO, PL, PT, RO, SE, SI, SK, SM, TR), OAPI (BF, BJ, CF, CG, CI, CM, GA, GN, GQ, GW, ML, MR, NE, SN, TD, TG).

Declarations under Rule 4.17:

— of inventorship (Rule 4.17(iv))

Published:

— with international search report (Art. 21(3))

(54) Title: METHOD FOR PRODUCING HIGHLY PALATABLE DRY CAT FOOD

(57) Abstract: The present invention relates to a method for producing highly palatable dry cat foods, by providing dry cat food preparations having specific compositions and/or texture properties, and by adding thereto palatability enhancers, so as to obtain highly palatable dry cat foods. Preferably, the present invention provides highly palatable dry cat foods having a rigidity below or equal to about 100 N/mm. Also is the present invention related to a method for increasing the palatability effect of a liquid palatability enhancer for use in dry cat food preparation, and to kits useful for enhancing palatability of dry cat foods.



WO 2010/146060 A1

METHOD FOR PRODUCING HIGHLY PALATABLE DRY CAT FOOD

BACKGROUND OF THE INVENTION

5 The present invention relates to a method for producing highly palatable dry cat foods, by providing dry cat food preparations having specific compositions and/or texture properties, and by adding thereto palatability enhancers, so as to obtain said highly palatable dry cat foods. Preferably, the present invention provides highly palatable dry cat foods having a rigidity below or equal to about 100 N/mm.

10 The present invention relates to complete and balanced dry foods for cats. Pets are well taken care of by their owners who provide them a proper selection of foods. Those foods include not only their usual diet, but also any supplements, treats, and toys. When designing foods for pets such as dogs and cats, optimal health and wellness are important goals. Nevertheless, the most nutritious pet food is of little value if the animals reject or refuse to eat
15 the food, or if the pet's consumption of food is restricted because the pet finds the food unpalatable. Pets, like humans, are attracted to and eat more regularly and easily foods which they find palatable. In this respect, cats especially are very sensitive to food palatability, so that their feeding behaviour has often been referred to as "finicky". Therefore, palatability is an extremely important criterion for pet consumption, and there is a continuous need for increasing
20 palatability of pet food, especially of cat food.

Animal foods (or pet foods) typically contain flavour compositions to increase the palatability thereof, and to make them appealing or appetizing to pets. It is known that palatability of dry pet food may be enhanced by some palatable components. As an example, in US 5,186,964 patent, Gierhart discloses a palatability composition comprising sodium acid pyrophosphate to improve
25 cat food palatability. Another example is described in US 5,690,988 patent, wherein palatability of the cat food is increased by adding a choline compound.

Continuing efforts are made to provide pet foods with improved palatability. And, adding flavours is not the only solution to increase pet food palatability. For example, US patent application No. 2008/057152 describes a method of ensuring acceptance of a cat food by
30 providing specific macronutrient content parameters. It thus appears that there are different ways to enhance cat food palatability, resulting in more or less satisfying levels of food consumption by cats.

As a consequence, there is a continuing need for improving pet food palatability, especially cat food palatability, and it is of high interest to find palatability-improving conditions that are
35 acceptable for the manufacturers, e.g., at moderated costs.

SUMMARY OF THE INVENTION

An object of the present invention relates to a method for producing a palatable dry cat food, comprising at least:

- 5 a) producing a dry cat food preparation having a rigidity below or equal to about 100 N/mm;
b) adding at least one palatability enhancer to said dry cat food preparation; and
c) obtaining a palatable dry cat food, wherein said palatable dry cat food has a rigidity below or equal to about 100 N/mm.

Preferably, said dry cat food preparation comprises at least one ingredient selected from:

- 10 - phyllosilicates,
- glucomannans and functional equivalents thereof,
- water-binding proteinaceous materials containing at least 65% proteins, and
- combinations thereof.

Another object of the present invention is a method for producing a palatable dry cat food, comprising at least:

- 15 a) producing a dry cat food preparation comprising at least one ingredient selected from:
- phyllosilicates,
- glucomannans and functional equivalents thereof,
- water-binding proteinaceous materials containing at least about 65% proteins, and
20 - combinations thereof;
b) adding at least one palatability enhancer to said dry cat food preparation; and
c) obtaining a palatable dry cat food.

Preferably, said palatable dry cat food has a rigidity below or equal to about 100 N/mm.

Also, preferably, in step a) above, said dry cat food preparation is extruded prior to drying.

- 25 Another object of the present invention concerns a palatable dry cat food obtainable by the foregoing method.

Yet another object of the present invention relates to the use of at least one ingredient as mentioned above for preparing a palatable dry cat food preferably having a rigidity below or equal to about 100 N/mm.

- 30 It is still an object of the present invention to provide a method for increasing the palatability effect of a liquid palatability enhancer intended to be added to a dry cat food, comprising at least:

a) providing a dry cat food or a dry cat food preparation, wherein said dry cat food or said dry cat food preparation preferably has a rigidity below or equal to about 100 N/mm;

- b) adding said liquid palatability enhancer to said dry cat food or said dry cat food preparation; and
- c) obtaining a palatable dry cat food, wherein the palatability effect of said liquid palatability enhancer is increased.
- 5 The present invention further relates to palatability-enhancing kits for producing palatable dry cat foods preferably having a rigidity below or equal to about 100 N/mm.

BRIEF DESCRIPTION OF THE DRAWINGS

10 Figure 1: Photographs of a Lloyd TA Plus Texture Analyzer, as an appropriate device for measuring texture properties of a pet food. A: TA Plus Texture Analyzer. B: Load cell and probe details of the device.

Figure 2: Probe photographs and details. The photographs C1) and C2) are views of the stainless cone probe observed under 2 different angles. The pictures D1), D2) , D3) and D4) are technical cross section views with dimensions given in millimeters.

15 Figure 3: Schematisation of a product texture analysis using a TA Plus Texture Analyzer. A: (1) Kibble to be analyzed; (2) cone probe; (3) table base. B: (2) cone probe; (3) table base; (4) pieces of kibble.

20 Figure 4: Graph representing the texture of a standard dry cat food as measured with a TA Plus Texture Analyzer according to a compression-until-breaking procedure. (1) Preload; (2) highest peak (i.e., Max Force (N)); (3) breaking detection corresponding to 0.15 x Max Force; (4) deformation after preload detection (in mm); (5) slope (i.e., rigidity (N/mm)); (6) surface under the curve until $y = \text{Max Force}$ (i.e., work (J or N.m)).

DETAILED DESCRIPTION OF THE INVENTION

25 Definitions

All references herein to “food” or “foodstuff” are intended to only refer to a dry food that is manufactured and sold for cat consumption. In the present context, the terms “pet food for cats”, “pet food”, “cat food”, “dry cat food”, and “dry pet food” are interchangeably used to refer to all types of balanced and complete dry foods for cats.

30 The terms “balanced (and) complete pet food” herein refer to a nutritionally adequate feed for companion animals having all nutrients in the proper amount and proportion for sustaining life without additional food. The balanced complete petfood can thus be fed as a sole ration. In other words, a balanced complete pet food excludes chews, treats, and the like.

The pet foods available on the market may be classified in three groups based upon their
35 moisture content:

- canned or wet or high-moisture foods (generally, of at least 50% moisture), which typically are the most palatable to the pets;
- dry or low-moisture foods (generally, containing less than 15% moisture), which typically have high nutritional content, least expensive packaging, greatest convenience, but are less palatable; and
- semi-moist or semi-dry or soft dry or intermediate or medium-moisture foods (typically with about 15 to 50% moisture), that are commonly less palatable than canned foods but more palatable than dry foods.

According to this classification, the terms “dry pet food” mean a pet food having less than 15% moisture. Typically, dry pet food is produced as kibbles. The term “kibbles” refers to particulate pieces formed by either a pelleting or extrusion process. The pieces can vary in sizes and shapes, depending on the process or the equipment. Importantly, the dry pet food of the present invention is a crunchy, crispy food. More particularly, the dry pet food of the present invention is under the form of kibbles that are crunchy, crispy pieces. This means that a relative force is required to bite the food in the mouth, and that a low sound is generally generated upon deformation and/or fracture. This differs from wet and semi-moist pet food that present a soft texture easy to chew, with pliable characteristics.

The term “moisture” is the total amount of water present in a food, or in a sample thereof. The moisture of a pet food is a standard quantitative parameter that can be easily determined by the person skilled in the art using conventional techniques and means.

The term “palatability” means a relative preference of an animal for one food composition over another. Palatability may be determined by a standard testing protocol wherein the animal has equal access to both compositions. Such preference can arise from any of the animal’s senses, but typically relates to taste, aroma, flavour, texture, and mouthfeel. A pet food, especially a cat food, herein indicated as having “enhanced” or “improved” or “increased” palatability is one for which a pet animal, especially a cat, exhibits preference relative to a control food composition.

The terms “palatability enhancers” or “palatants” or “flavours” or “palatability agents” or “appetizing factors” or “palatant components” or “palatability materials” mean any material that enhances the palatability of a food composition to an animal. A palatability enhancer may be a single material or a blend of materials. When a blend of materials, it is not necessary that all materials in the blend be palatable or be as palatable as each other, provided that the blend as a whole is palatable. Also, a palatability enhancer may be natural, processed or unprocessed, synthetic, or part of natural and part of synthetic materials. Palatability enhancers can be liquids or powders (dry). They can be used by coating and/or by inclusion. Palatability enhancers are

commonly used in the technical field of the present invention. A large variety of palatability enhancers are thus commercially available.

The terms “palatability-enhancing kit” is a kit comprising one or more palatability enhancers and or one or more appropriate food ingredients such as phyllosilicates, glucomannans and
5 functional equivalents thereof (such as galactomannans), and water-binding proteinaceous materials containing at least 65% proteins.

In the context of the present invention, an “ingredient” or a “food ingredient” is a pet food additive or a pet food component that is used for conferring palatability to a pet food preparation or for improving said palatability. An ingredient as defined herein has water-binding properties
10 that have been found by the Inventors to be of high interest for modifying the dry pet food texture in such a way that this pet food is palatable to the pet. More precisely, an ingredient is herein selected from phyllosilicates, glucomannans and functional equivalents thereof, water-binding proteinaceous materials containing at least 65% proteins, and combinations thereof.

Phyllosilicates are sheet silicates, formed by parallel sheets of silicate tetrahedra with Si₂O₅ or a
15 2:5 ratio. The term “phyllosilicate” is generically used herein to encompass any mineral including but not limited to: Akermatite, Aliettite, Allophane, Aluminoceladonite, Amesite, Anandite, Annite, Antigorite, Apophyllite, Aspidolite, Baileychlore, Batavite, Beidellite, Bementite, Bensonite, Bentonite, Berthierine, Biotite, Bismutoferrite, Bityite, Boromuscovite, Borocookeite, Bowlingite, Brammalite, Brindleyite, Bronrobersite, Brokenhillite, Burckhardtite,
20 Caryopilite, Cavansite, Celadonite, Chamosite, Champmanite, Chernykhite, Chlorite, Chlorite group, Chromceladonite, Chromphyllite, Chrysocolle, Chrysolite; Chrysotile, Clay mineral group, Clinochlore, Clintonite, Cookeite, Corrensite, Cronstedtite, Damouzite, Delessite, Dickite; Donbassite, Dozyite, Eastonite, Eirikite, Ephesite, Falcondoite, Fedorite, Ferripyrophyllite, Ferrisurite, Ferro-aluminoceladonite, Ferroceladonite, Ferrokinoshitalite,
25 ferrosaponite, Fireclay, Fluorannite, Fluorophogopite, Fraipontite, Franklinfurnaceite, Friedelite, Fuchsite, Ganterite, Garnierite, Gehlenite, Glagolevite, Glauconite, Gonyerite, Greenalite, Grumantite, Gyrolite, Halloysite, Hectorite, Hendricksite, Hisingerite, Hydrobiotite, Illite, Imogolite, Intersilite, Kalifersite, Kaolinite, Karpinskite, Kegelite, Kellyite, Kinoshitalite, Kulkeite, Kurumsakite, Lalondeite, Ledikite, Leifite, Lepidolite, Lizardite, Loughlinite,
30 Lunijianlaite, Macaulayite, Makatite, Manandonite, Manganoneptunite, Margarite, Martinite, Masutomilite, Magillite, Medicinal clay, Melilite, Mica group, Mica, Minchillite, Minnesotaite, Montdorite, Montmorillonite, Muscovite, Nacrite, Nafersite, Nanpingite, Natrosilite, Nelenite, Neotocite, Nepouite, Niksergievite, Nimite, Nontronite, Norrishite, Odinite, Okenite, Orlymanite, Orthochamosite, Oxykinoshitalite, Palygorskite (attapulgitite), Paragonite, Pecoraite,
35 Pennantite, Petalite, Phlogite, Phlogopite, Polyolithionite, Preiswerkite, Pyrophyllite,

Pyrosmalite-(Fe), Pyrosmalite-(Mn), Raite, Rectorite, Reyerite, Roscoelite, Saliotite, Saponite, Sarcosite, Sauconite, Schallerite, Sepiolite, Sericite, Serpentine, Serpentine group, Shafranovskite, Shirokshinite, Shirozulite, Siderophyllite, Smectite, Sokolovaite, Spadaite, Stevensite, Stilpnomélane, Sudoite, Suhailite, Surite, Swinefordite, Tainiolite, Talc, Telyushenkoite, Tetra-ferriphlogopite, Tetraferriannite, Tobelite, Tosudite, Trilithionite, Tupperussuaite, Tungusite, Truscottite, Ussingite, Varennesite, Vermiculite, Volkhonskoite, Watatsumiite, Willemsite, Wonesite, Yakhontovite, Yofortierite, Zakharovite, Zeophyllite, Zincsilite, and Zinnwaldite. Any type or form of phyllosilicate that is acceptable for use in a pet food may be used in the present invention. Preferred examples of phyllosilicates suitable for use in the present invention are selected from montmorillonite, bentonite, kaolinite, sepiolite, and vermiculite. Zeolite (or zeolithe) does not belong to the phyllosilicate but to the tectosilicate class.

Glucoman is a polysaccharide composed of long chains of simple sugars, primarily mannose and glucose. It is classified as a water-soluble fiber. It is commonly isolated from konjac root (Amorphophallus konjac) but can also be isolated from other natural sources as plants or yeasts. Konjac glucoman does not contain any wheat, gluten, carbohydrates, calories, fat, protein or sugar. The molecular weight of konjac glucoman varies from 200,000 to 2,000,000 depending on the species or variety, the processing method and even the storage time of raw material. Glucoman may also be referred to as, *inter alia*: Konjac glucoman, Manna, Konjac, Konjac Fiber, Konjac flour, Konnyaku, Elephant-Foot Yam, and Devil's Tongue. Konjac glucoman is known to have properties of reversible water-holding capacity and thermo-non-reversible gel formation.

The terms “functional equivalents of glucomannans” are to be construed here to encompass any compounds, structurally-related to glucomannans or not, that have water-binding properties. Thus, the only requirement for a compound to be a functional equivalent of glucoman is that it is capable of binding water, even if it binds water less efficiently than glucomannans. It will be however advantageous to use compounds that are capable of binding water in the same extent than glucomannans. Preferred functional equivalents of glucomannans are galactomannans, including without limitation, guar gum, locust bean gum, tara gum, and cassia gum.

The terms “water-binding proteinaceous materials” are herein synonymous of “proteins having textural functional properties” by contrast to any protein included in pet foodstuffs for nutritional purposes. In the present context, water-binding proteinaceous materials are pet food components having at least water-binding ability or water holding capacity (WHC). They can have further interesting physico-chemical properties, including other textural properties such as

fat-binding, gelation, whippability, and the like. These properties may contribute with water-binding ability to impart palatability and/or other advantageous features to the food from an organoleptic and/or textural (but not nutritional) point of view. For the purposes of the present invention, water-binding proteinaceous materials contain at least about 65%, preferably at least about 70%, yet preferably at least about 75%, and even more preferably at least about 80%, 85%, 90%, 95%, proteins. These proteinaceous materials preferably are natural, from animal or vegetal origin. These proteinaceous materials are more preferably from animal origin.

Water-binding proteinaceous materials useful in the present invention include without limitation pea protein concentrates, soya protein concentrates, soya protein isolates, and more preferably animal proteinaceous materials as whey protein concentrates, sodium caseinates, natural cold setting pork proteins, and functional equivalents thereof.

By “functional equivalents thereof”, it is meant herein water-binding proteinaceous materials as defined above, from animal origin and containing at least about 65% proteins, preferably at least about 70%, yet preferably at least about 75%, and even more preferably at least about 80%, 85%, 90%, 95%, proteins. Advantageously, these “functional equivalents” further are proteinaceous materials containing at least about 4% hydroxyproline. Preferably, they contain at least about 5% hydroxyproline. In particular, they contain from about 4 to about 20% hydroxyproline, preferably from about 4 to about 15% hydroxyproline. Yet preferably, they contain from about 5 to about 20% hydroxyproline, even more preferably from about 5 to about 15% hydroxyproline.

As mentioned above, “proteins having textural functional properties” are proteins having water-binding capacity (resulting in, e.g., hydrogen bonding of water, water-absorption, entrapment of water), but they may have additional textural and/or organoleptic properties such as solubility, thickening, gelation (protein matrix formation and setting), elasticity (formation and stabilization of fat emulsions), flavor binding (adsorption, entrapment, release), etc.

The term “texture” herein refers to the distinctive physical composition or structure of a pet food, in particular of a dry pet food and especially of a dry cat food.

The term “hardness” means a measure of the resistance of a material to surface indentation and abrasion. The term “hardness” is also equivalent to “peak force” or “maximal force”. The term “maximal force” (or FMax) is defined as the force of the first compression enquired for sample’s breakage. It represents the resistance of extrudate to initial penetration. Usually a hard product will be associated with high maximal force. The expressed unit of “Force” is Newton (N).

The term “deformation” is represented as the point (distance) at which the peak force is reached.

The term “deformation” is also equivalent to “strain” or to “travel” or to “distance of

penetration". It is attributed to a measurement of how far the probe has travelled to reach the maximum force. The expressed unit of deformation is millimetre (mm).

The term "rigidity" represents the amount of resistance with which a body opposes change of form. The "rigidity" parameter is calculated as being equal to Maximal Force (N) divided by deformation (mm). The rigidity can also be called "firmness". Instrumental firmness is primarily the deformation modulus of the material under test and was obtained from the slope of the initial linear portion of the force deformation curve (Anton *et al*, 2007; Ravi *et al*, 2007). Firmness is commonly measured for foods such as snacks food extrudates, cornstarch extrudates, chewing gums, and the like. Rigidity can be compared to Young's modulus, which describes the tendency of an object to deform along an axis when opposing forces are applied along that axis. Young's modulus is defined as the ratio of stress to strain. A material with a high Young's modulus is told "rigid".

The term "work" is defined as an estimate of work. It corresponds to the work necessary to induce the first major failure of the sample and expresses the ability of the material to absorb mechanical energy prior to failure. It is the area of the curve until $y = F_{max}$ (Maximal Force) and it is expressed as N.m or Joules.

The term "water activity" (or A_w) is a measurement of the energy status of the water in a system. It is represented by a quotient between water's partial pressure in the food and pure water's partial pressure. It indicates how tightly water is bound, structurally or chemically, within a substance. This is measured by equilibrating the liquid phase (in the sample) with the vapor phase (in the headspace) and measuring the relative humidity of that space.

The term "density" or "bulk density" means a measure of how much mass is contained in a given unit volume. It is commonly expressed in grams per litre (g/L). Density may be measured using a cubic box or cylindrical tube having one litre volume capacity.

Description of the invention

The Inventors could observe that the food texture has an impact onto food consumption by pets. This impact is generally significant in all pets, including dogs and cats. However, in the latter, the food texture appears to be of very high relevance. These observations led the Inventors to try to find means for binding and/or entrapping water in the food, expecting a positive impact onto food palatability. By doing so, they indeed could show for the first time, as it is reported in detail herein, that producing specifically textured foods could enhance palatability of dry cat foods, and in turn favour food consumption by cats.

An aspect of the present invention relates to a method for producing a palatable dry cat food, comprising at least:

- a) producing a dry cat food preparation having a rigidity below or equal to about 100 N/mm;
- b) adding at least one palatability enhancer to said dry cat food preparation; and
- c) obtaining a palatable dry cat food, wherein said palatable dry cat food has a rigidity below or equal to about 100 N/mm.

5 In one embodiment, said dry cat food is single-textured. Alternatively, said dry cat food may be a mix of single-textured dry cat foods, each thereof having a rigidity below or equal to about 100 N/mm.

The rigidity of said dry cat food preparation in step a) and/or of said palatable dry cat food obtained in step c) of the method according to the invention is preferably from about 50 N/mm to about 100 N/mm, yet preferably from about 55 N/mm to about 95 N/mm, and yet more preferably from about 60 N/mm to about 90 N/mm.

In the method according to the present invention, several ways to reach the targeted food rigidity may be used alone or in combination. Preferred examples of suitable ways are described below.

15 In one embodiment, said dry cat food preparation in step a) above comprises at least one ingredient selected from:

- phyllosilicates,
- glucomannans and functional equivalents thereof,
- water-binding proteinaceous materials containing at least about 65% proteins, and
- 20 - combinations thereof.

These ingredients will be used alone or in combination, at an appropriate dose for achieving the final rigidity of the dry cat food preparation, said rigidity being below or equal to about 100 N/mm. Such doses will be easily determined by the person skilled in the art using standard methods.

25 Another aspect of the present invention thus relates to a method for producing a palatable dry cat food, comprising at least:

a) producing a dry cat food preparation comprising at least one ingredient selected from:

- phyllosilicates,
- glucomannans and functional equivalents thereof,
- 30 - water-binding proteinaceous materials containing at least about 65% proteins, and
- combinations thereof;

b) adding at least one palatability enhancer to said dry cat food preparation; and

c) obtaining a palatable dry cat food.

Preferably, said palatable dry cat food has a rigidity below or equal to about 100 N/mm. The rigidity of said dry cat food preparation in step a) and/or of said palatable dry cat food obtained

in step c) of the method according to the invention is preferably from about 50 N/mm to about 100 N/mm, yet preferably from about 55 N/mm to about 95 N/mm, and yet more preferably from about 60 N/mm to about 90 N/mm.

Dry pet foods represent a nutritionally balanced mixture containing proteins, fibres, carbohydrates and/or starch, fats. Such mixtures are well known to those skilled in the art, and their composition/formulation depends on many factors such as, for example, the desired food balance for the specific category of pets. In addition to these base elements, the food may include vitamins, minerals and other additives such as seasonings, preservatives. Specific suitable amounts for each component in a composition will depend on a variety of factors such as the species of animal consuming the composition, the particular components included in the composition, the age, weight, general health of the animal, and the like. Therefore, the component amounts may vary from one embodiment to another. The food balance, including the relative proportions of vitamins, minerals, lipids, proteins and carbohydrates, is determined according to the known dietary standards in the veterinary field, for example by following recommendations of the National Research council (NRC), or the guidelines of the American Association of Feed Control Officials (AAFCO).

All conventional protein sources may be used, obtained from a variety sources such as plants, animals, or both. Animal proteins include poultry meal, meat meal and bone meal, fish meal, casein, egg powder, albumin, and fresh animal tissue, for example fresh meat tissue and fresh fish tissue. Plant proteins include wheat gluten or gluten meal, soya. Other types of proteins include microbial proteins such as yeast.

The fat and carbohydrate food ingredient is obtained from a variety of sources such as animal fat, fish oil, vegetable oil, meat, meat by-products, grains, other animal or plant sources, and mixtures thereof. Grains include wheat, corn, barley, and rice. The fiber food ingredient is obtained from a variety of sources such as vegetable fiber sources, e.g., cellulose, beet pulp, peanut hulls, and soy fiber.

The food preparations may contain additional components such as vitamins, minerals, fillers, palatability enhancers, flavors, stabilizers, coatings, and the like, well known to the skilled artisans. Therefore, the component amounts may vary from one embodiment to another. Standard dry cat food formulations are well known to the person skilled in the art. Examples of recipes are given in, e.g., International patent application No. WO 2003/039267.

Preferably, said dry cat food preparation in step a) above comprises said at least one ingredient in combination with at least one palatability enhancer, the latter being appropriate for incorporation by inclusion into the cat food preparation.

Advantageously, in step a) above, the cat food preparation is extruded prior to drying.

Preferably, extrusion is performed under appropriate conditions in order to obtain an extruded cat food preparation having a density from about 300 g/L to about 450 g/L. Yet preferably, the extruded cat food preparation has a density from about 350 g/L to about 400 g/L.

The final moisture of the dry cat food (preparation) is less than 15% moisture. Preferably, said
5 final moisture is from about 3% to about 10%. Yet preferably, it is from about 3% to about 8%.
Such a moisture content of the dry cat food leads to a water activity below 0.65. This is sufficient to prevent growth of pathogenic microorganisms in the product. Therefore, there is no need for adding humectants (include, but not limited to, propylene glycol, glycerol, sugar, sorbitol and salt) or antimicrobials agents (include, but not limited to, potassium sorbate,
10 propionic acid and its salts, sodium benzoate, nitrites and nitrates salts).

Prior to drying, or prior to extrusion and drying, the cat food preparation may be ground under appropriate conditions for obtaining fine food particles, such as particles having an about 500- to about 1500- μ m diameter, with a preferred range from about 500- to about 1000- μ m diameter.

Dry pet foods are commonly prepared by different methods. One of these methods, that is a
15 widely used one, is a cooker-extruder method. Dry ingredients, including animal protein sources, plant protein sources, grains, etc., are ground and mixed together. Moist or liquid ingredients, including fats, oils, animal protein sources, water, etc., are then added to and mixed with the dry mix. The mixture is then processed into kibbles or similar dry pieces. Kibble is often formed using an extrusion process in which the mixture of dry and wet ingredients is
20 subjected to mechanical work at a high pressure and temperature, and forced through small openings or dies and cut off into kibble by a rotating knife. This die forms the extruded product into a specific shape. The wet kibble is then dried in a hot air dryer. Generally, the product is dried until it contains less than 15% moisture, and typically about 5 to 10% moisture. The dried particles or pieces are then transferred by conveyor to a coating system and sprayed with fat.
25 Particles can optionally be coated with one or more topical coatings, which may include palatability enhancers, flavours, powders, and the like.

Noticeably, in step a) of the method as described above, the dry cat food preparation and/or any of the components thereof is (are) not contacted with alpha-amylase.

In one embodiment of the method of the present invention, in step b) as defined above, said
30 added palatability enhancer is selected from liquid and/or dry palatability enhancers, and combinations thereof. Such a palatability enhancer is appropriate for being added to the cat food by coating.

Coating, as used herein, refers to the topical deposition of the palatability enhancer or flavour composition onto the surface basal composition, such as by spraying, dusting, or the like. For
35 example, kibbles of uncoated, extruded basal pet food can be placed in a container such a tub or

a coating drum for mixing. A fat, such as pork fat or poultry fat, is heated and then sprayed onto the pet food in a manner to obtain a coating of the kibbles. The coating need not to be a continuous layer, but preferably is uniform. After the fat, a palatability enhancer may be applied as either a liquid or a dry powder, or both, while the kibbles are mixed. A liquid palatability enhancer is typically sprayed on, while a dry palatability enhancer is typically dusted on. Alternatively, palatability enhancers could be mixed with the fat and applied concurrently. In another alternative method of coating, palatability enhancers are coated before deposition of fat. Another aspect of the present invention concerns a palatable dry cat food obtainable by a method as described above. Preferably, this palatable dry cat food has a rigidity below or equal to about 100 N/mm.

Yet another aspect of the present invention relates to the use of at least one ingredient selected from:

- phyllosilicates,
- glucomannans and functional equivalents thereof,
- water-binding proteinaceous materials containing at least about 65% proteins, and
- combinations thereof,

for preparing a palatable dry cat food preferably having a rigidity below or equal to about 100 N/mm.

Yet another aspect of the present invention is directed to a method for increasing the palatability effect of a liquid palatability enhancer intended to be added to a dry cat food, comprising at least:

- a) providing a dry cat food or a dry cat food preparation, wherein said dry cat food or said dry cat food preparation preferably has a rigidity below or equal to about 100 N/mm;
- b) adding said liquid palatability enhancer to said dry cat food or said dry cat food preparation;
- and
- c) obtaining a palatable dry cat food, wherein the palatability effect of said liquid palatability enhancer is increased.

In step b), addition of the liquid palatability enhancer to the food or the food preparation is done by coating.

Preferably, said dry cat food or said dry cat food preparation in step a) is produced as per step a) of the method for producing a palatable dry cat food as described above.

Further aspects of the present invention are related to palatability-enhancing kits useful for producing palatable dry cat foods preferably having a rigidity below or equal to about 100 N/mm and/or for enhancing palatability of dry cat foods preferably having a rigidity below or equal to about 100 N/mm.

In one embodiment, such a palatability-enhancing kit contains at least one ingredient selected from:

- phyllosilicates,
- glucomannans and functional equivalents thereof,
- 5 - water-binding proteinaceous materials containing at least about 65% proteins, and
- combinations thereof.

Preferably, such a kit further contains at least one palatability enhancer, especially at least one palatability enhancer suitable for use by inclusion into the food.

10 In another embodiment, a kit according to the present invention contains at least one liquid palatability enhancer and at least one dry palatability enhancer as a combined preparation for simultaneous, separate or sequential use for increasing the palatability of a dry cat food having preferably a rigidity below or equal to about 100 N/mm. These palatability enhancers are preferably suitable for being added to the food by coating.

Preferably, such a kit further contains at least one ingredient selected from:

- 15 - phyllosilicates,
- glucomannans and functional equivalents thereof,
- water-binding proteinaceous materials containing at least about 65% proteins, and
- combinations thereof.

20 In yet another embodiment, a palatability-enhancing kit according to the present invention contains:

a) at least one ingredient selected from:

- phyllosilicates,
- glucomannans and functional equivalents thereof,
- water-binding proteinaceous materials containing at least about 65% proteins, and
- 25 - combinations thereof, and

b) at least one palatability enhancer,

as a combined preparation for simultaneous, separate or sequential use for producing a palatable dry cat food preferably having a rigidity below or equal to about 100 N/mm. Here, the palatability enhancer(s) provided in the kit may be for a use by inclusion and/or by coating.

30 Another aspect of the present invention concerns a method for feeding a cat, comprising: feeding a cat, a palatable dry cat food as described above.

The invention can be further illustrated by the following examples, although it will be understood that these examples are included merely for purposes of illustration and explanation, and are not intended in any way to limit the scope of the present invention.

EXAMPLES

A- MATERIALS AND METHODS

5 Texture Measurement

Texture measurements were performed with a Lloyd TA plus Texture Analyzer (Lloyd Instruments, trademark of AMETEK, Inc. and part of AMETEK Measurement & Calibration Technologies (Lloyd Instruments Ltd; Steyning Way Bognor Regis West Sussex, PO22 9ST, UK; AMETEK, Inc. 37 N. Valley Road, Building 4 P.O. Box 1764 Paoli, PA 19301 U.S.A) (Fig. 1). This texture analyzer has been conceived to perform test compression until breaking (Fig. 3). It measures force and deformation, and the stress-strain curve. The device is composed of a full bridge strain gauged load cell, a stainless steel cone probe (figure 2), a base table where the analyzed product is put. The cone probe (figure 2) has been designed to resemble to a dog tooth so that the analyzer can mimic the biting of a dog. This device is also appropriate and conventionally used for cat food analysis.

A puncture test was run measuring force over distance using a piece of equipment such as the TA plus Texture Analyzer (Fig. 1). Each piece or sample "1" is placed on the base of the analyzer, under the probe, so that the probe "2" will contact the narrowest point of the sample at a direction of a 90° angle while the sample is positioned lying flat on the base as illustrated in Fig. 3.

The probe "2" runs at a test speed of 35 mm/ minute (speed of probe before contact with the sample). The force in Newton N (y axis) is plotted against distance in mm (x axis). The "starting force" or "preload" is 1 N. It represents the value of the "pre-loading" in order to prevent measuring differences that would only be due to variations in size or shape of the kibbles and to have comparable data independently of any specific shape or size of the kibbles. The preload permits to exclude the distance covered by the probe from the starting point until it contacts the sample. Without this preload, a difference in kibble thickness would induce a different deformation measure. The Max Force is the maximum amount of force needed to achieve the kibble breaking (Fig. 4). The following parameters were measured: the Max Force (N), which is the maximum force value of the curve, the Deformation (mm) and Work (N.m) which is the area under the curve (Fig. 4). For each of these parameters, the measurement was the average of the values of at least 40 samples of the product tested. The rigidity parameter (N/mm) was calculated for each piece analyzed, as the slope of the stress-strain curve. The final rigidity value was the average of the values of at least 40 samples of the product tested.

Palatability assessment

Palatability effects are conventionally measured by a test that is known as the “two-bowl test” or “versus test”. Of course, the person skilled in the art is free to use any other appropriate test than the two bowl test herein described to determine preference. Such alternative tests are well known in the art.

Principle of the two-bowl test:

The test is based on the postulate whereby the more food consumed, the more palatable it is.

Individual versus or Two bowls appetite tests, based on the comparison between two foods, were carried out, with bowls presented simultaneously and sides (right and left) were daily reversed. Tests are performed on panel of 40 cats.

Operating method of the test:

- Identical amounts of food A and food B were weighed out and placed in identical bowls. The amount present in each ration enables the daily requirements to be met.

- Distribution of the bowls:

The bowls were presented at the same time to each cat in an individual loose box and their positions were switched at each meal to avoid a choice lead by handedness.

- Duration of the cat palatability test:

15 minutes minimum (if one of the two bowls was entirely eaten before 30 minutes, the two bowls were removed, and the test was stopped) to 16 hours maximum.

Parameters studied

- Measured parameters: First food consumed and amount of each food consumed by the end of the test

- Calculated parameters: individual consumption ratio in % (CR)

$CR_A = \text{consumption of A(g)} \times 100 / \text{consumption of A+B (g)}$

$CR_B = \text{consumption of B(g)} \times 100 / \text{consumption of A+B (g)}$;

⇒ Average consumption ratio (ACR) = average of each individual ratios (an equal importance is given to each animal, regardless of its size and of its corresponding consumption)

If animals have higher or lower consumption compared to determined values, they are not taken into account into statistical treatment

Statistical analysis:

Statistical analysis was used to determine if there was a significant difference between the 2 ratios: ACR ⇒ Student's t-test with 3 error thresholds, namely 5%, 1% and 0.1%.

A Chi test was used to determine if there was a significant difference between the number of cats with Food A as first food eaten and the number of cats with Food B as first food eaten.

Significance levels are noted as below:

- NS not significant (p > 0.05)
- * significant (p < 0.05)
- ** highly significant (p < 0.01)
- *** very highly significant (p < 0.001)

5

B- EXAMPLES

Example 1: Example of coated kibbles of different rigidity values: below 50 N/mm, between 50 N/mm and 100 N/mm, and above 100 N/mm.

10 Kibbles have been coated with 3% poultry fat, then 3% super premium liquid palatability enhancer and then 1% super premium dry palatability enhancer.

As shown in Table 1 below, dry cat food compositions that had higher rigidity value but below 100 N/mm exhibited greater intake ratios than dry cat food compositions that had lower rigidity value. Results showed that the palatability preference was so more significant that the rigidity values for the two compared dry cat food compositions were between 20 N/mm and 68 N/mm and more preferably between 20 N/mm and 57 N/mm. Palatability results showed that differences of intake ratio were significantly decreased for two dry cat food compositions that had rigidity values between 57 N/mm and 92 N/mm and more preferably between 67 N/mm and 92 N/mm

20 The results in Table 1 below also exhibited that the dry cat food compositions that had rigidity below 100 N/mm (72 N/mm) exhibited greater intake ratio than dry cat food composition that had rigidity value above 100 N/mm (112 N/mm).

Table 1

Product A rigidity (N/mm)	Product B rigidity (N/mm)	Ref tests	Consumption ratio			
				% A	% B	Significance (Student test)
20	37	C0700103	Day 1	23	77	***
			Day 2	24	76	***
37	57	C0700102	Day 1	32	68	***
			Day 2	25	75	***
57	68	C0700101	Day 1	36	64	*
			Day 2	43	56	NS
67	92	C0801683	Day 1	57	43	NS
			Day 2	59	41	NS
72	112	C0801874	Day 1	63	37	**
			Day 2	60	40	*

(NS): Not Significant (p > 0.05)

(*): significant (p < 0.05), (**): highly significant (p < 0.01), (***): very highly significant (p < 0.001)

These results clearly demonstrate the relevance of fixing an upper limit to the dry cat food rigidity at about 100 N/mm.

5 **Example 2 : Inclusion of specific ingredients (phyllosilicates, glucomannans and proteins having functional properties) into the cat food preparation before extrusion of the final kibbles. Example of kibbles coated with poultry fat, liquid and dry palatability enhancers.**

This example demonstrates the effect of phyllosilicates, glucomannans and proteins having functional properties as texture agents which increase the rigidity value when added to a dry cat
 10 food composition and which in turn increase the palatability of the dry cat food composition. For each comparison, the preparations of dry cat foods were similar, with the difference being that the test composition included phyllosilicates, and/or glucomannans and/or proteins having functional properties, incorporated to the dough before extrusion. The test compositions were compared against the control composition in a palatability test. All kibbles have been coated
 15 with 6% poultry fat, then 3% super premium liquid palatability enhancer and then 1% super premium dry palatability enhancer. Rigidity measurements have been determined for each cat food composition. The experiment has been conducted onto different kibbles compositions. As shown below in Table 2 below, the experimental tests compositions, including specific ingredients, exhibited greater intake preference than the control compositions, while the rigidity
 20 values are higher for those test compositions than for the control compositions.

Table 2

Product A	Product B	Ref tests	Product A rigidity (N/mm)	Product B rigidity (N/mm)	Consumption ratio			Significance (Student test)
						% A	% B	
Dry cat food 1 with 2% phyllosilicate	Dry cat food 1 control	C0800916	59	51	Day 1	64	36	**
					Day 2	60	40	*
Dry cat food 3 with 2% phyllosilicate	Dry cat food 3 control	C0801796	56	50	Day 1	61	39	*
					Day 2	65	35	**
Dry cat food 1 with 0,5% glucomannan	Dry cat food 1 control	C0800918	61	49	Day 1	69	31	***
					Day 2	65	35	*
Dry cat food 1 with 1% glucomannan	Dry cat food 1 control	C0802610	63	47	Day 1	62	38	**
					Day 2	66	34	**
Dry cat food 2 with 1% proteins with functional properties	Dry cat food 2 control	C0900036	70	62	Day 1	61	39	*
					Day 2	71	29	***

(NS): Not Significant (p> 0.05), (*): significant (p<0.05), (**): highly significant (p<0.01),

(***): very highly significant ($p < 0.001$)

Proteins with functional properties = a natural cold setting pork protein, Glucomannan= konjac powder, Phyllosilicate= kaolinite

5

Example 3: Palatability assessment of dry cat food comprising at least one ingredient selected from phyllosilicates, glucomannans, and proteins with functional properties, in combination with a palatability enhancer

10 This example demonstrates the effect of combining phyllosilicates, glucomannans and/or proteins with functional properties with palatable components for both increasing the rigidity value when added to a dry cat food composition and increasing the palatability of the dry cat food composition. For each comparison, the preparations of dry cat foods were similar, with the difference being that the test composition included phyllosilicates, or glucomannans or proteins with functional properties combined to palatable ingredients, incorporated to the dough before
15 extrusion. Depending on tests, palatable components could be dry palatability enhancer, dry palatable meat meal and dry palatable fish meal.

The test compositions were compared against the control composition in a palatability test. The experiment has been conducted with different kibbles compositions, and with different top coatings, each composition being coated with 6% poultry fat, and then either 3% super premium
20 liquid palatability enhancer and 1% super premium dry palatability enhancer, or 2% dry palatability enhancer. Rigidity measurements have been determined for each cat food composition. As shown below in Table 3 below, the experimental tests compositions, including specific ingredients combined with palatable components, exhibited greater intake preference than the control compositions, while the rigidity values are higher for those test compositions
25 than for the control compositions.

Table 3

Product A	Product B	Ref tests	Product A rigidity (N/mm)	Product B rigidity (N/mm)	Consumption ratio			Significance (Student test)
						% A	% B	
Top coating : 6% poultry fat, then 3% super premium liquid palatability enhancer and then 1% super premium dry palatability enhancer								
Dry cat food 1 with (1% Glcm+ 10% PE1)	Dry cat food control	C0802515	75	48	Day 1	75	25	***
					Day 2	75	25	***
Dry cat food 2 with (1% Glcm + 10% PE2)	Dry cat food control	C0801372	60	48	Day 1	67	33	***
					Day 2	68	32	**
Top coating : 6% poultry fat, then 2% super premium dry palatability enhancer								
Dry cat food 3 with (1% Glcm + 5% PE1)	Dry cat food control	C0801179	64	48	Day 1	69	31	***
					Day 2	67	33	***
Dry cat food 4 with (1% Glcm + 5% PE2)	Dry cat food control	C0801181	57	48	Day 1	70	30	***
					Day 2	67	33	***

(NS): Not Significant (p> 0.05), (*): significant (p<0.05), (**): highly significant (p<0.01), (***): very highly significant (p<0.001)

PE1= Palatability enhancer 1 poultry based, PE2= Palatability enhancer 1 pork based,

5 Glcm = Glucomannan (konjac powder)

Example 4: Relevance on palatability, of the drying conditions used for preparing a dry cat food.

10 This example demonstrates the effect of drying onto the rigidity values for dry cat food compositions dried at different moisture content levels, and the resulting enhancement of the palatability results.

For each comparison, the preparations of dry cat foods were similar, with the difference being that the compositions were dried at different moisture contents. The experiment has been conducted with different kibbles compositions, and with different top coatings, each
 15 compositions being coated with 6% poultry fat, and then either 3% super premium liquid palatability enhancer or 1% super premium dry palatability enhancer or both liquid and dry palatability enhancers. The compositions were compared in a palatability test. For each cat food composition, palatability tests have been conducted in order to compare cat food composition with higher moisture content and cat food composition with lower moisture content. Rigidity
 20 measurements have been determined for each cat food composition. As shown below in Table 4 below, the cat food compositions with lower moisture content exhibited greater intake preference than the cat food compositions with higher moisture content. The cat food compositions with lower moisture content exhibited higher rigidity value than the cat food compositions with higher moisture content.

Table 4

Product A	Product B	ref tests	Product A rigidity (N/mm)	Product B rigidity (N/mm)	Consumption ratio			Significance (Student test)
						% A	% B	
Top coating : 6% poultry fat, then 1% super premium dry palatability enhancer								
Dry cat food 1 - 6% moisture content	Dry cat food 1 - 7% moisture content	C0700099	58	48	Day 1	74	26	***
					Day 2	74	26	***
Dry cat food 1 - 7% moisture content	Dry cat food 1 - 9% moisture content	C0700097	48	27	Day 1	75	25	***
					Day 2	76	24	***
Top coating : 6% poultry fat, then 3% super premium liquid palatability enhancer								
Dry cat food 3 - 6% moisture content	Dry cat food 3 - 7,5% moisture content	C0700094	54	48	Day 1	59	41	*
					Day 2	64	36	**
Top coating : 6% poultry fat, then 3% super premium liquid palatability enhancer and then 1% super premium dry palatability enhancer								
Dry cat food 4 - 7,5% moisture content	Dry cat food 4 - 9% moisture content	C0700102	57	37	Day 1	68	32	***
					Day 2	75	25	***
Dry cat food 4 - 9% moisture content	Dry cat food 4 - 10% moisture content	C0700106	38	26	Day 1	79	21	***
					Day 2	72	28	***
Dry cat food 5 - 7% moisture content -	Dry cat food 5- 8% moisture content -	10035383	60	53	Day 1	65	35	***
		10035392			Day 2	71	29	***

(NS): Not Significant ($p > 0.05$), (*): significant ($p < 0.05$), (**): highly significant ($p < 0.01$), (***): very highly significant ($p < 0.001$)

5 **Example 5: Relevance on palatability, of the extruding conditions used for preparing a dry cat food.**

This example demonstrates the effect of extrusion onto the rigidity values for dry cat food compositions produced at different density levels and the resulting enhancement of the palatability results.

10 For each comparison, the preparations of dry cat foods were similar, with the difference being that the compositions were extruded either at 420 grams per liter density or at 340 grams per liter. The speed of the screws of the twin screws extruder and the vapor inlets have been modified in order to obtain the density values. Both cat food compositions have been dried at the same moisture content. All kibbles have been coated with 3% poultry fat, then 3% super premium liquid palatability enhancer and then 1% super premium dry palatability enhancer.

15 Rigidity measurements have been determined for each cat food composition. Palatability tests have been conducted in order to compare cat food composition with higher density and cat food composition with lower density. As shown below in Table 5 below, the cat food compositions

with lower density exhibited greater intake preference than the cat food compositions with higher density. The cat food compositions with lower density exhibited lower rigidity value than the cat food compositions with higher density. The cat food composition with higher density showed a rigidity value of 108 N/mm, that is over the about 100 N/mm upper limit.

5

Table 5

Product A	Product B	ref tests	Product A rigidity (N/mm)	Product B rigidity (N/mm)	Consumption ratio			Significance (Student test)
						% A	% B	
Dry cat food 1 – 420 g/l density	Dry cat food 2 – 340 g/l density	C0801886	108	55	Day 1	48	52	NS
					Day 2	35	65	***

(NS): Not Significant ($p > 0.05$), (*): significant ($p < 0.05$), (**): highly significant ($p < 0.01$), (***): very highly significant ($p < 0.001$)

Example 6: kibbles produced with 2% phyllosilicates added by inclusion before extrusion, combined with final moisture content variation (drying conditions).

10

This example demonstrates the positive combined effect of adding phyllosilicates as a texture agent and of using appropriate drying conditions, for increasing the rigidity value and in turn the palatability of a dry cat food composition. For each comparison, the preparations of dry cat foods were similar, with the difference being that the test composition included phyllosilicates, incorporated to the dough before extrusion. Two levels of final moisture contents (6% and 8%) have been conducted. The tests compositions were compared against the control composition in a palatability test. All kibbles have been coated with 6% poultry fat, then 3% super premium liquid palatability enhancer and then 1% super premium dry palatability enhancer. Rigidity measurements have been determined for each cat food composition. The experiment has been conducted onto different kibbles compositions. As shown in Table 6 below, the phyllosilicate tests compositions exhibited greater intake preference than the control compositions, while the rigidity values are higher for the phyllosilicate tests compositions than for the control compositions. Lower moisture content (6%) kibbles show higher rigidity values than higher moisture content (8%).

20

Table 6

Product A	Product B	Ref tests	Product A rigidity (N/mm)	Product B rigidity (N/mm)	Consumption ratio			Significance (Student test)
						% A	% B	
Dry cat food 1 with 2% phyllosilicates - 8% Moisture content	Dry cat food Control 1 - 8% moisture content	C0802120	49	38	Day 1	59	41	*
					Day 2	59	41	*
Dry cat food 3 with 2% phyllosilicates - 6% Moisture content	Dry cat food Control 3 - 6% moisture content	C0800916	59	51	Day 1	64	36	**
					Day 2	60	40	*

(NS): Not Significant ($p > 0.05$), (*): significant ($p < 0.05$), (**): highly significant ($p < 0.01$), (***): very highly significant ($p < 0.001$)
 Phyllosilicate= kaolinite

5

Example 7: kibbles produced with 0.5% or 1% glucomannans added by inclusion before extrusion, combined or not with liquid palatability enhancer added by coating.

This example demonstrates the effect of glucomannans in increasing the appetizing effect of a liquid palatability enhancer when added to a dry cat food composition. Table 7 below gives the results of the 3 following sets of comparative experiments.

10

1) Effect of a liquid palatability enhancer in the absence of glucomannans: a dry cat food composition 1 without glucomannans added but coated with 6% poultry fat, then 3% super premium liquid palatability enhancer and then 1% super premium dry palatability enhancer exhibited a greater intake ratio than the same cat food composition 1 coated only with 6% poultry fat and 1% dry palatability enhancer. The rigidity value is lower for the dry cat food composition coated with liquid and dry palatability enhancers than for the dry cat food composition coated only with dry palatability enhancer.

15

2) Effect of glucomannans in the absence of a liquid palatability enhancer: the second comparison showed a higher intake ratio for a dry cat food composition 2 with glucomannans added in the dough before extrusion and coated with 6% poultry fat and 1% dry palatability enhancer compared to a dry cat food composition 2 without glucomannans added before extrusion and coated with 6% poultry fat and 1% dry palatability enhancer. For this second comparison, the rigidity value for the cat food composition with glucomannans was higher than the cat food composition without glucomannan addition.

20

3) Effect of a liquid palatability enhancer in the presence of glucomannans: the third comparison exhibited an increased appetizing effect and a more significant preference for a cat food composition 3 which combines glucomannans added in the dough before extrusion and

25

coated with 6% poultry fat, then 3% super premium liquid palatability enhancer and then 1% super premium dry palatability enhancer than for a dry cat food composition 3 with glucomannans added in the dough before extrusion and coated with 6% poultry fat and 1% super premium dry palatability enhancer only. Results showed that the appetizing effect of the liquid palatability enhancer is higher significant when combined with glucomannans added in the dough before extrusion than the appetizing effect of the liquid palatability enhancer without glucomannans added. The rigidity value of the dry cat food composition with glucomannans added in the dough before extrusion and coated with liquid palatability enhancer is higher than the rigidity value of the dry cat food composition without glucomannans and coated with liquid palatability enhancer. The rigidity value of the dry cat food composition with glucomannans added in the dough before extrusion and coated with liquid palatability enhancer is also higher than the rigidity value of the dry cat food composition with glucomannans added in the dough and without liquid palatability enhancer added.

Table 7

Product A	Product B	Ref tests	Product A rigidity (N/mm)	Product B rigidity (N/mm)	Consumption ratio			Significance (Student test)
						% A	% B	
Dry cat food 1 coated 3% liquid PE+ 1% dry PE	Dry cat food 1 coated 1% dry PE	C800919	48	54	Day 1	60	40	*
					Day 2	63	37	*
Dry cat food 2 with 1% Glcm coated 1% dry PE	Dry cat food 2 coated 1% dry PE	C800925	64	50	Day 1	60	40	*
					Day 2	59	41	*
Dry cat food 3 with 0.5% Glcm coated 3% liquid PE + 1% dry PE	Dry cat food 3 with 0.5% Glcm coated 1% dry PE	C800927	65	59	Day 1	70	28	**
					Day 2	74	26	***

(PE): Palatability enhancer, (NS): Not Significant ($p > 0.05$), (*): significant ($p < 0.05$), (**): highly significant ($p < 0.01$), (***) : very highly significant ($p < 0.001$)
 Glcm: glucomannans (konjac powder)

Example 8 : Inclusion of zeolite into a cat food preparation before extrusion of the final kibbles. Example of kibbles coated with poultry fat, liquid and dry palatability enhancers.

This example demonstrates the effect of zeolite when added to a dry cat food composition and which in turn does not increase the palatability of the dry cat food composition. For each comparison, the preparations of dry cat foods were similar, the only difference being that the test composition included zeolite, incorporated to the dough before extrusion. The test compositions were compared to a control composition in a palatability test. All kibbles have been coated with 6% poultry fat, then 3% super premium liquid palatability enhancer and then 1% super premium dry palatability enhancer. Rigidity measurements have been determined for

each cat food composition. The experiment has been conducted onto same kibble compositions. As shown in Table 8 below, the experimental test compositions, including zeolite, did not exhibit greater intake preference than the control compositions, while the rigidity values are not higher for those test compositions than for the control compositions.

5

Table 8

Product A	Product B	Ref tests	Product A rigidity (N/mm)	Product B rigidity (N/mm)	Consumption ratio		Significance (Student test)	
						% A		% B
Dry cat food 1 with 2% zeolite	Dry cat food 1 control	C0901303	50	54	Day 1	43	57	*
					Day 2	34	66	***

(NS): Not Significant ($p > 0.05$), (*): significant ($p < 0.05$), (**): highly significant ($p < 0.01$), (***): very highly significant ($p < 0.001$)

REFERENCES

- 5 Anton, A.A., Luciano, F.B. (2007). Instrumental texture evaluation of extruded snack foods: a review. *Ciencia y Tecnologia Alimentaria* , 5 (4) 245-251
- Ravi, R., Roopa, B.S., Bhattacharya, S. (2007). Texture evaluation by uniaxial compression of some snack foods. *Journal of texture studies*, 38 (1) 135-152

CLAIMS

1. A method for producing a palatable dry cat food, comprising at least:
- 5 a) producing a dry cat food preparation having a rigidity below or equal to about 100 N/mm;
b) adding at least one palatability enhancer to said dry cat food preparation; and
c) obtaining a palatable dry cat food, wherein said palatable dry cat food has a rigidity below or equal to about 100 N/mm.
- 10 2. The method according to claim 1, wherein said rigidity of said dry cat food preparation in step a) and/or said palatable dry cat food obtained in step c) is from about 50 N/mm to about 100 N/mm.
3. The method according to claim 1 or 2, wherein said dry cat food preparation comprises
- 15 at least one ingredient selected from:
- phyllosilicates,
 - glucomannans and functional equivalents thereof,
 - water-binding proteinaceous materials containing at least about 65% proteins, and
 - combinations thereof.
- 20 4. A method for producing a palatable dry cat food, comprising at least:
- a) producing a dry cat food preparation comprising at least one ingredient selected from:
- phyllosilicates,
 - glucomannans and functional equivalents thereof,
 - 25 - water-binding proteinaceous materials containing at least about 65% proteins, and
 - combinations thereof;
- b) adding at least one palatability enhancer to said dry cat food preparation; and
c) obtaining a palatable dry cat food.
- 30 5. The method according to claim 4, wherein said palatable dry cat food has a rigidity below or equal to about 100 N/mm.
6. The method according to anyone of claims 3 to 5, wherein said dry cat food preparation comprises said at least one ingredient in combination with at least one palatability enhancer.

7. The method according to anyone of claims 1 to 6, wherein in step a), said dry cat food preparation is extruded prior to drying.
8. The method according to claim 7, wherein said extruded cat food has a density from
5 about 300 g/L to about 450 g/L.
9. The method according to claim 7, wherein said dry cat food has a final moisture from about 3% to about 10%.
- 10 10. The method according to anyone of claims 1 to 9, wherein in step b), said added palatability enhancer is selected from liquid and/or dry palatability enhancers, and combinations thereof.
11. A palatable dry cat food obtainable by a method according to anyone of claims 1 to 10.
15
12. Use of at least one ingredient selected from:
- phyllosilicates,
- glucomannans and functional equivalents thereof,
- water-binding proteinaceous materials containing at least about 65% proteins, and
20 - combinations thereof,
for preparing a palatable dry cat food, said palatable dry cat food preferably having a rigidity below or equal to about 100 N/mm.
13. A method for increasing the palatability effect of a liquid palatability enhancer intended
25 to be added to a dry cat food, comprising at least:
a) providing a dry cat food or a dry cat food preparation, wherein said dry cat food or said dry cat food preparation preferably has a rigidity below or equal to about 100 N/mm;
b) adding said liquid palatability enhancer to said dry cat food or said dry cat food preparation;
and
30 c) obtaining a palatable dry cat food, wherein the palatability effect of said liquid palatability enhancer is increased.
14. A palatability-enhancing kit containing at least one ingredient selected from:
- phyllosilicates,
35 - glucomannans and functional equivalents thereof,

- water-binding proteinaceous materials containing at least about 65% proteins, and
- combinations thereof,

for producing a palatable dry cat food, wherein said palatable dry cat food preferably has a rigidity below or equal to about 100 N/mm.

5

15. A palatability-enhancing kit containing at least one liquid palatability enhancer and at least one dry palatability enhancer as a combined preparation for simultaneous, separate or sequential use for increasing the palatability of a dry cat food, said dry cat food preferably having a rigidity below or equal to about 100 N/mm.

10

16. The kit according to claim 15, further containing at least one ingredient selected from:

- phyllosilicates,
- glucomannans and functional equivalents thereof,
- water-binding proteinaceous materials containing at least about 65% proteins, and
- combinations thereof.

15

17. A palatability-enhancing kit containing:

a) at least one ingredient selected from:

- phyllosilicates,
- glucomannans and functional equivalents thereof,
- water-binding proteinaceous materials containing at least about 65% proteins, and
- combinations thereof, and

20

b) at least one palatability enhancer,

as a combined preparation for simultaneous, separate or sequential use for producing a palatable dry cat food having preferably a rigidity below or equal to about 100 N/mm.

25

1/4

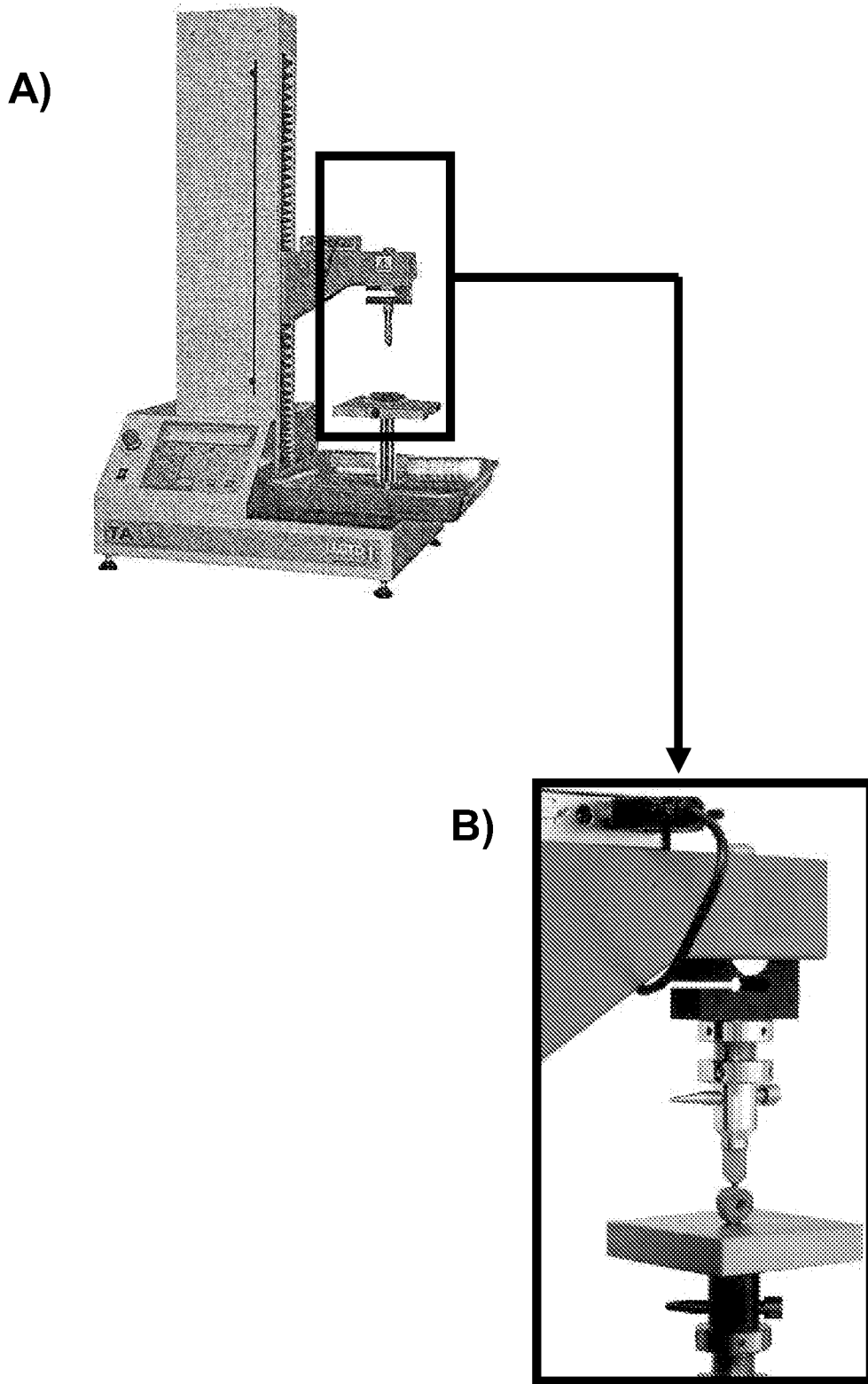

FIGURE 1

2/4

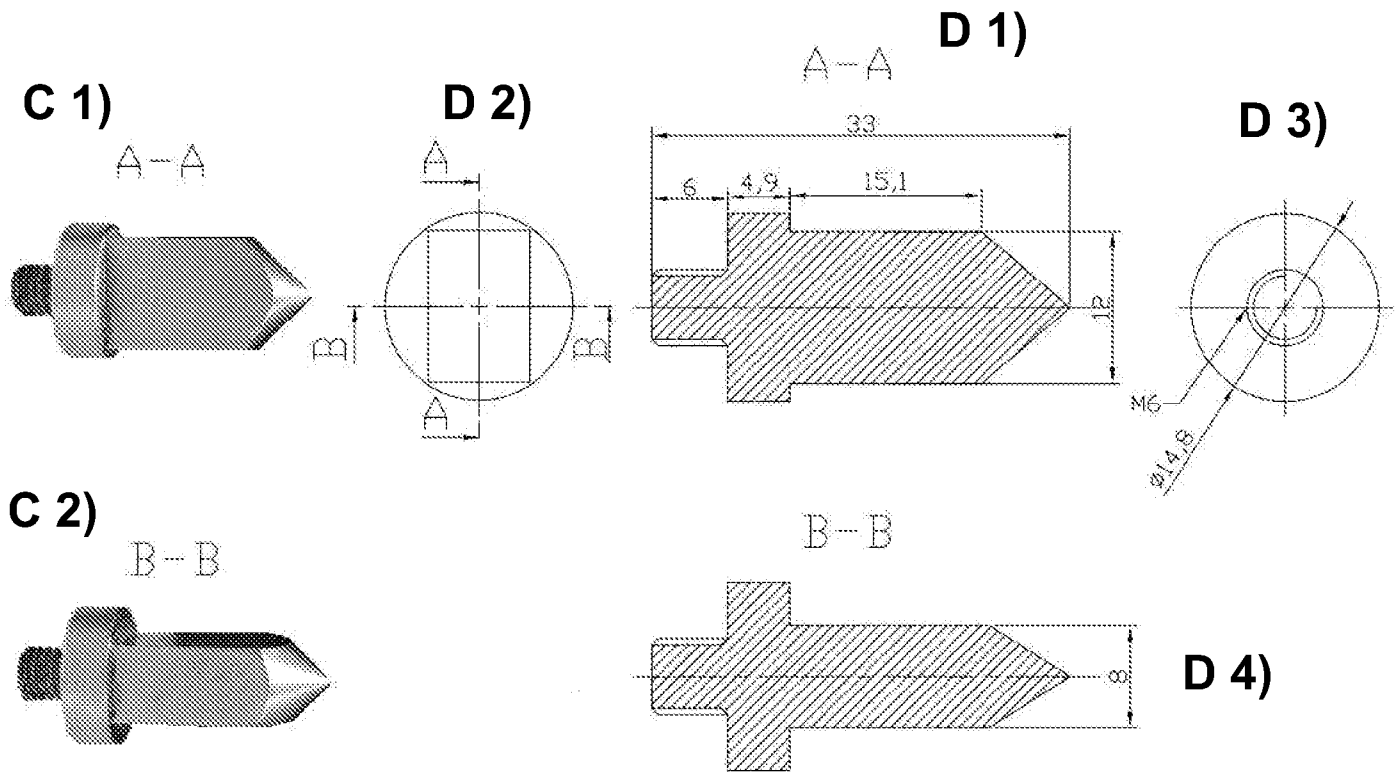

FIGURE 2

3/4

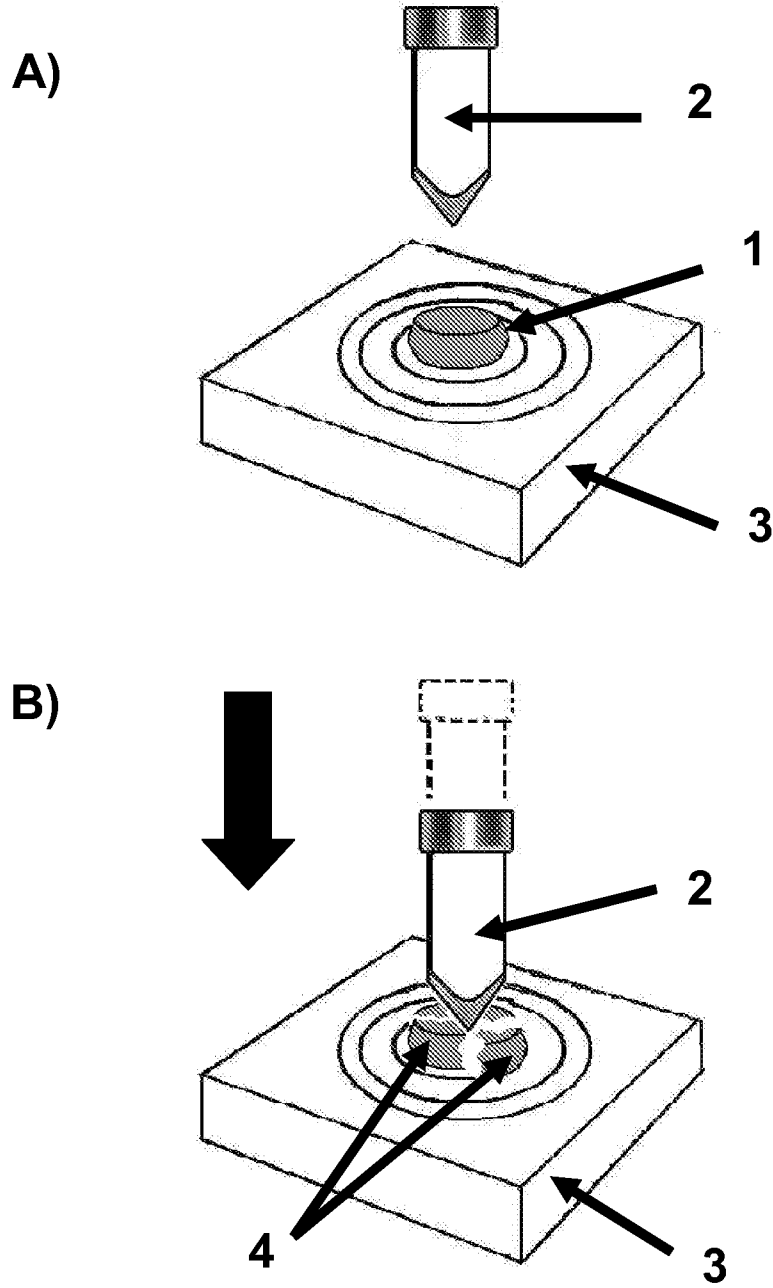

FIGURE 3

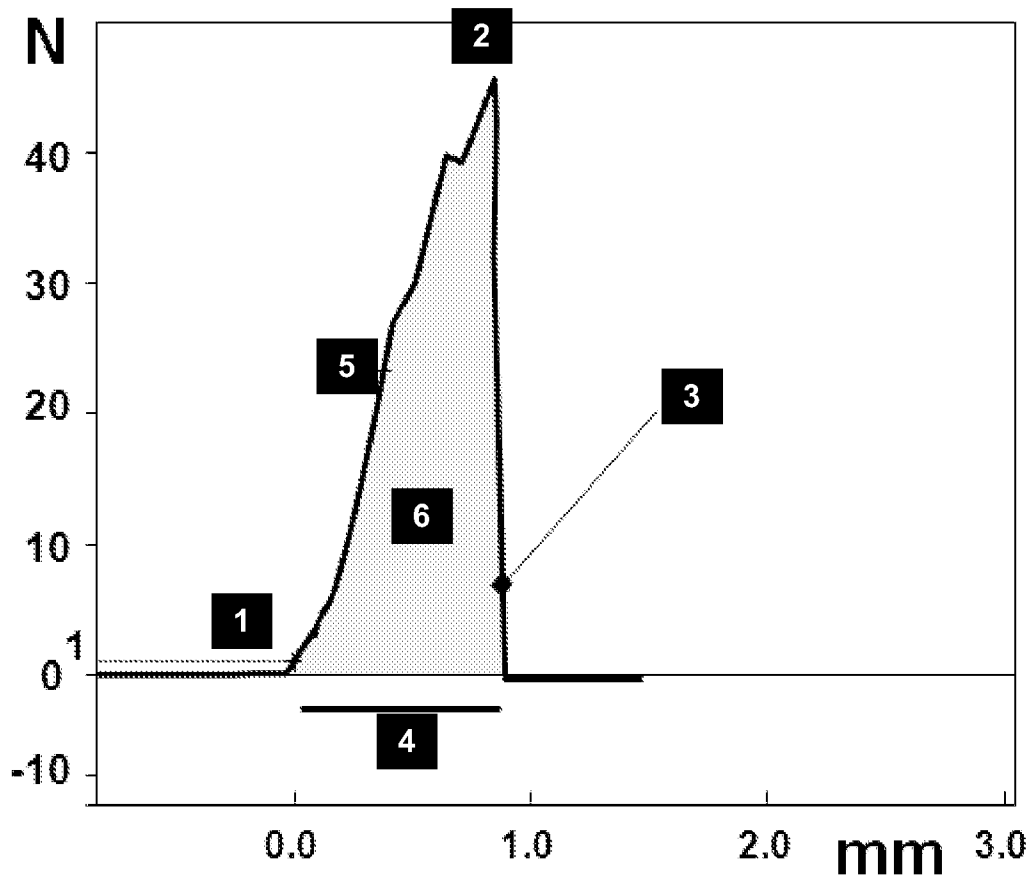

FIGURE 4

INTERNATIONAL SEARCH REPORT

International application No
PCT/EP2010/058405

A. CLASSIFICATION OF SUBJECT MATTER
 INV. A23K1/16 A23K1/175 A23K1/18
 ADD.

According to International Patent Classification (IPC) or to both national classification and IPC

B. FIELDS SEARCHED

Minimum documentation searched (classification system followed by classification symbols)
 A23K

Documentation searched other than minimum documentation to the extent that such documents are included in the fields searched

Electronic data base consulted during the international search (name of data base and, where practical, search terms used)
 EPO-Internal, BIOSIS, FSTA, PAJ, WPI Data

C. DOCUMENTS CONSIDERED TO BE RELEVANT

Category*	Citation of document, with indication, where appropriate, of the relevant passages	Relevant to claim No.
X	US 2004/076718 A1 (PARTHASARATHY MUKUND [US]) 22 April 2004 (2004-04-22) paragraphs [0001], [0010], [0011], [0020], [0023] - [0024], [0033], [0040], [0051]	1,2, 7-11,13
X	WO 2006/122196 A2 (HILLS PET NUTRITION INC [US]; YAMKA RYAN MICHAEL [US]; KATS LAUREN JAY) 16 November 2006 (2006-11-16) paragraphs [0011], [0012], [0023], [0027], [0034], [0038], [0045], [0046], [0047], [0052] - [0056], [0059] example 1 tables 2,3 paragraph [0068] claims 1-3,10	1,2, 7-11,13, 15

Further documents are listed in the continuation of Box C. See patent family annex.

- | | |
|--|---|
| <p>* Special categories of cited documents :</p> <ul style="list-style-type: none"> *A* document defining the general state of the art which is not considered to be of particular relevance *E* earlier document but published on or after the international filing date *L* document which may throw doubts on priority claim(s) or which is cited to establish the publication date of another citation or other special reason (as specified) *O* document referring to an oral disclosure, use, exhibition or other means *P* document published prior to the international filing date but later than the priority date claimed | <ul style="list-style-type: none"> *T* later document published after the international filing date or priority date and not in conflict with the application but cited to understand the principle or theory underlying the invention *X* document of particular relevance: the claimed invention cannot be considered novel or cannot be considered to involve an inventive step when the document is taken alone *Y* document of particular relevance: the claimed invention cannot be considered to involve an inventive step when the document is combined with one or more other such documents, such combination being obvious to a person skilled in the art. *&* document member of the same patent family |
|--|---|

Date of the actual completion of the international search 22 July 2010	Date of mailing of the international search report 29/07/2010
--	---

Name and mailing address of the ISA/ European Patent Office, P.B. 5818 Patentlaan 2 NL - 2280 HV Rijswijk Tel. (+31-70) 340-2040. Fax: (+31-70) 340-3016	Authorized officer Couzy, François
--	--

INTERNATIONAL SEARCH REPORT

International application No
PCT/EP2010/058405

C(Continuation). DOCUMENTS CONSIDERED TO BE RELEVANT

Category*	Citation of document, with indication, where appropriate, of the relevant passages	Relevant to claim No.
X	US 2007/292594 A1 (LEVIN MARK [US]) 20 December 2007 (2007-12-20) paragraphs [0001], [0005], [0006], [0014], [0017], [0019] - [0020], [0027] example 3 -----	1-17
A	WO 2006/009354 A1 (SONG KI YOUNG [KR]) 26 January 2006 (2006-01-26) paragraphs [0009] - [0014], [0037] - [0039], [0042], [0049] - [0057] -----	1-15
A	WO 2007/149962 A1 (MARS INC [US]; TORNEY ALLAN A [CA]; UNLU EMINE [US]; WILLCOCKS NEIL [U]) 27 December 2007 (2007-12-27) paragraphs [0001], [0007], [0014] - [0015], [0017] - [0020], [0023] examples 1-4 paragraph [0033] -----	1-15
A	US 2003/228409 A1 (FRITZ-JUNG CATHRYN KATI [US] ET AL) 11 December 2003 (2003-12-11) paragraphs [0001], [0004], [0006], [0025], [0030] - [0031] claim 1 -----	1-15

INTERNATIONAL SEARCH REPORT

International application No.
PCT/EP2010/058405

Box No. II Observations where certain claims were found unsearchable (Continuation of item 2 of first sheet)

This international search report has not been established in respect of certain claims under Article 17(2)(a) for the following reasons:

1. Claims Nos.:
because they relate to subject matter not required to be searched by this Authority, namely:

2. Claims Nos.: **1-3, 5-17(all partially)**
because they relate to parts of the international application that do not comply with the prescribed requirements to such an extent that no meaningful international search can be carried out, specifically:
see FURTHER INFORMATION sheet PCT/ISA/210

3. Claims Nos.:
because they are dependent claims and are not drafted in accordance with the second and third sentences of Rule 6.4(a).

Box No. III Observations where unity of invention is lacking (Continuation of Item 3 of first sheet)

This International Searching Authority found multiple inventions in this international application, as follows:

1. As all required additional search fees were timely paid by the applicant, this international search report covers all searchable claims.

2. As all searchable claims could be searched without effort justifying an additional fees, this Authority did not invite payment of additional fees.

3. As only some of the required additional search fees were timely paid by the applicant, this international search report covers only those claims for which fees were paid, specifically claims Nos.:

4. No required additional search fees were timely paid by the applicant. Consequently, this international search report is restricted to the invention first mentioned in the claims; it is covered by claims Nos.:

Remark on Protest

- The additional search fees were accompanied by the applicant's protest and, where applicable, the payment of a protest fee.
- The additional search fees were accompanied by the applicant's protest but the applicable protest fee was not paid within the time limit specified in the invitation.
- No protest accompanied the payment of additional search fees.

FURTHER INFORMATION CONTINUED FROM PCT/ISA/ 210

Continuation of Box II.2

Claims Nos.: 1-3, 5-17(all partially)

The subject-matter of all claims 1-3 and 5-17 is partially defined by reference to the parameter "rigidity", which is required to be below or equal to about 100 N/mm. First, this is not a definition in terms of technical features of how to obtain such a rigidity. Second, the use of this parameter in technical documents is not usual in the technical field of pet foods. Lastly, the probe used for the texture analysis appears to be not commercially available, and it is not clear whether it was appropriately identified. Indeed, it appears that there is no information as regards the "stainless" material it is made of. It follows that the use of this unusual and incorrectly defined parameter in the present context is considered to lead to a lack of clarity, because the claims do not clearly identify the products and methods they encompass, since the parameter cannot be clearly and reliably determined by indications in the description or by objective procedures which are usual in the art. This makes it impossible to compare the claims with the prior art. As a result, the application does not comply with the requirement of clarity under Article 6 PCT. The lack of clarity and, also, of disclosure is such that a meaningful search of the whole claimed subject-matter of claim could not be carried out. The extent of the search was consequently limited to the subject-matter that is defined in terms of technical features, simply taking into account that the rigidity of the pet food might be somewhat lower.

The applicant's attention is drawn to the fact that claims relating to inventions in respect of which no international search report has been established need not be the subject of an international preliminary examination (Rule 66.1(e) PCT). The applicant is advised that the EPO policy when acting as an International Preliminary Examining Authority is normally not to carry out a preliminary examination on matter which has not been searched. This is the case irrespective of whether or not the claims are amended following receipt of the search report or during any Chapter II procedure. If the application proceeds into the regional phase before the EPO, the applicant is reminded that a search may be carried out during examination before the EPO (see EPO Guideline C-VI, 8.2), should the problems which led to the Article 17(2) declaration be overcome.

INTERNATIONAL SEARCH REPORT

Information on patent family members

International application No

PCT/EP2010/058405

Patent document cited in search report		Publication date	Patent family member(s)	Publication date
US 2004076718	A1	22-04-2004	AU 2003276083	A1 04-05-2004
			WO 2004034812	A1 29-04-2004
WO 2006122196	A2	16-11-2006	AU 2006244023	A1 16-11-2006
			CA 2607643	A1 16-11-2006
			CN 101217882	A 09-07-2008
			EP 1879469	A2 23-01-2008
			JP 2008539760	T 20-11-2008
			RU 2379944	C2 27-01-2010
			US 2009274796	A1 05-11-2009
			NONE	
US 2007292594	A1	20-12-2007	NONE	
WO 2006009354	A1	26-01-2006	KR 20040074648	A 25-08-2004
WO 2007149962	A1	27-12-2007	AU 2007260887	A1 27-12-2007
			CA 2655178	A1 27-12-2007
			EP 2037755	A1 25-03-2009
			JP 2009540836	T 26-11-2009
			US 2010003393	A1 07-01-2010
US 2003228409	A1	11-12-2003	AU 2003237923	A1 22-12-2003
			BR 0311691	A 22-03-2005
			CA 2489000	A1 18-12-2003
			CN 1658764	A 24-08-2005
			DE 60312158	T2 29-11-2007
			WO 03103411	A2 18-12-2003
			EP 1511392	A2 09-03-2005
			ES 2281648	T3 01-10-2007
			JP 4283766	B2 24-06-2009
			JP 2005528903	T 29-09-2005
			MX PA04012332	A 25-02-2005
			ZA 200500216	A 29-03-2006