



(86) Date de dépôt PCT/PCT Filing Date: 2004/06/24  
 (87) Date publication PCT/PCT Publication Date: 2005/01/20  
 (45) Date de délivrance/Issue Date: 2011/11/01  
 (85) Entrée phase nationale/National Entry: 2005/10/13  
 (86) N° demande PCT/PCT Application No.: EP 2004/006828  
 (87) N° publication PCT/PCT Publication No.: 2005/005946  
 (30) Priorité/Priority: 2003/07/09 (DE103 31 125.4)

(51) Cl.Int./Int.Cl. *G01K 15/00* (2006.01),  
*G01J 5/04* (2006.01)  
 (72) Inventeurs/Inventors:  
CUYPERS, JAN, BE;  
STRAETEMANS, MARC, BE  
 (73) Propriétaire/Owner:  
HERAEUS ELECTRO-NITE INTERNATIONAL N.V., BE  
 (74) Agent: MACRAE & CO.

(54) Titre : ALIGNEMENT ET MESURE DE TEMPERATURES DANS DES MASSES EN FUSION AU MOYEN DE FIBRES OPTIQUES

(54) Title: ALIGNING AND MEASURING TEMPERATURES IN MELTING BY MEANS OF OPTICAL FIBERS

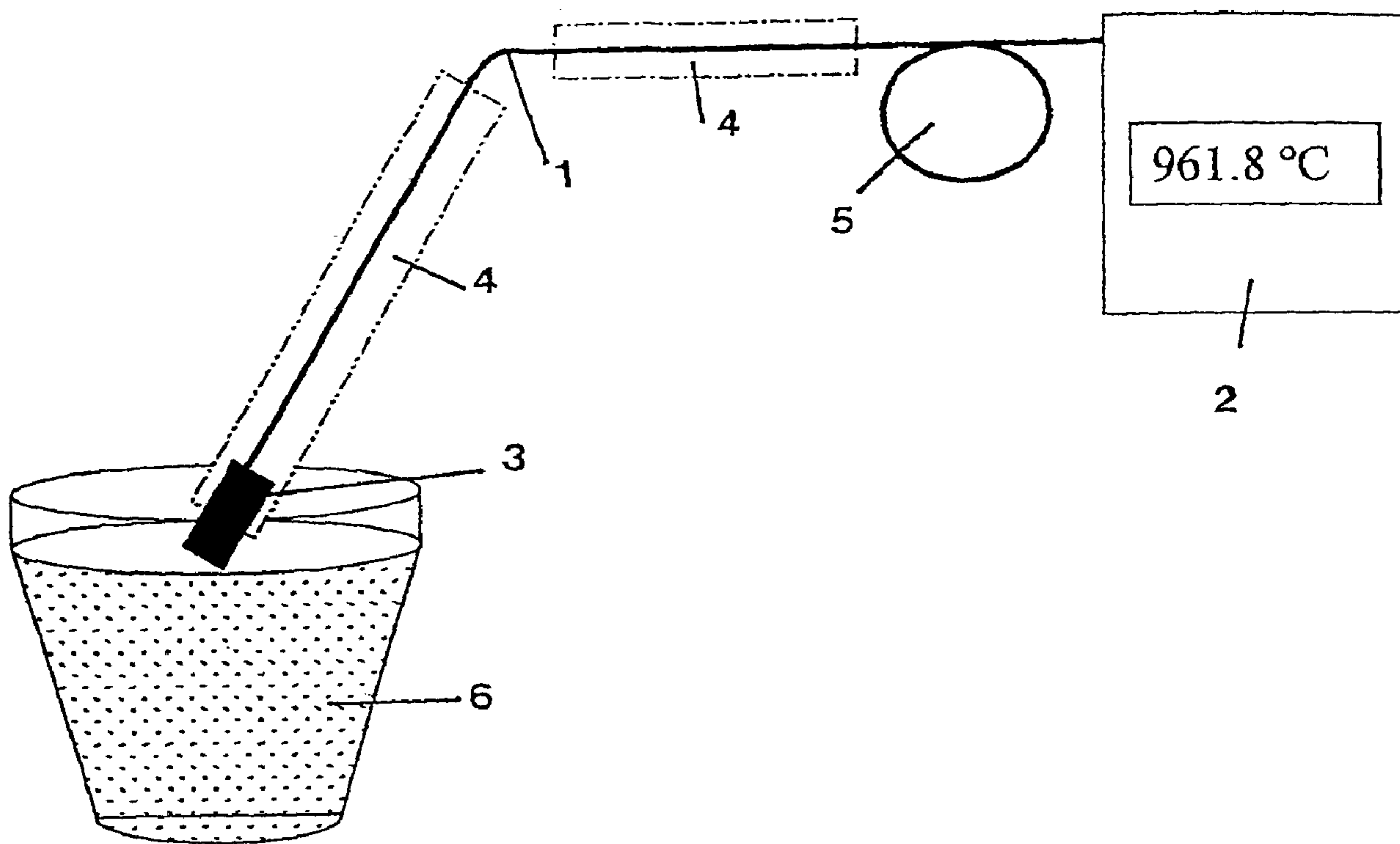

(57) Abrégé/Abstract:

The invention relates to a method for aligning measuring signals obtainable by means of optical fibres. The inventive method consists in arranging a reference material having a known reference temperature on the end of an optical fibre, heating said reference material to at least the reference temperature thereof, transferring the signal received by the optical fibre at the reference temperature to a measuring instrument in the form of an aligning signal and in comparing said signal with a theoretical reference temperature value, the difference therebetween being used for alignment. A corresponding device and the use thereof for calibrating or determining optical fibre attenuation is also disclosed.

## (12) NACH DEM VERTRAG ÜBER DIE INTERNATIONALE ZUSAMMENARBEIT AUF DEM GEBIET DES PATENTWESENS (PCT) VERÖFFENTLICHTE INTERNATIONALE ANMELDUNG

(19) Weltorganisation für geistiges Eigentum  
Internationales Büro(43) Internationales Veröffentlichungsdatum  
20. Januar 2005 (20.01.2005)

PCT

(10) Internationale Veröffentlichungsnummer  
**WO 2005/005946 A1**(51) Internationale Patentklassifikation<sup>7</sup>: **G01K 15/00**,  
G01J 5/04

(21) Internationales Aktenzeichen: PCT/EP2004/006828

(22) Internationales Anmeldedatum:  
24. Juni 2004 (24.06.2004)

(25) Einreichungssprache: Deutsch

(26) Veröffentlichungssprache: Deutsch

(30) Angaben zur Priorität:  
103 31 125.4 9. Juli 2003 (09.07.2003) DE(71) Anmelder (für alle Bestimmungsstaaten mit Ausnahme von US): **HERAEUS ELECTRO-NITE INTERNATIONAL N.V.** [BE/BE]; Centrum Zuid 1105, B-3530 Houthalen (BE).

(72) Erfinder; und

(75) Erfinder/Anmelder (nur für US): **CUYPERS, Jan** [BE/BE]; Square Vergote 36, B-1030 Brüssel (BE). **STRAETEMANS, Marc** [BE/BE]; Eikelbosstraat 2, B-3941 Hechtel-Eksel (BE).(74) **Anwalt: KÜHN, Hans-Christian**; Heraeus Holding GmbH, Schutzrechte, Heraeusstrasse 12-14, 63450 Hanau (DE).(81) **Bestimmungsstaaten** (soweit nicht anders angegeben, für jede verfügbare nationale Schutzrechtsart): AE, AG, AL, AM, AT, AU, AZ, BA, BB, BG, BR, BW, BY, BZ, CA, CH, CN, CO, CR, CU, CZ, DK, DM, DZ, EC, EE, EG, ES, FI, GB, GD, GE, GH, GM, HR, HU, ID, IL, IN, IS, JP, KE, KG, KP, KR, KZ, LC, LK, LR, LS, LT, LU, LV, MA, MD, MG, MK, MN, MW, MX, MZ, NA, NI, NO, NZ, OM, PG, PH, PL, PT, RO, RU, SC, SD, SE, SG, SK, SL, SY, TJ, TM,

[Fortsetzung auf der nächsten Seite]

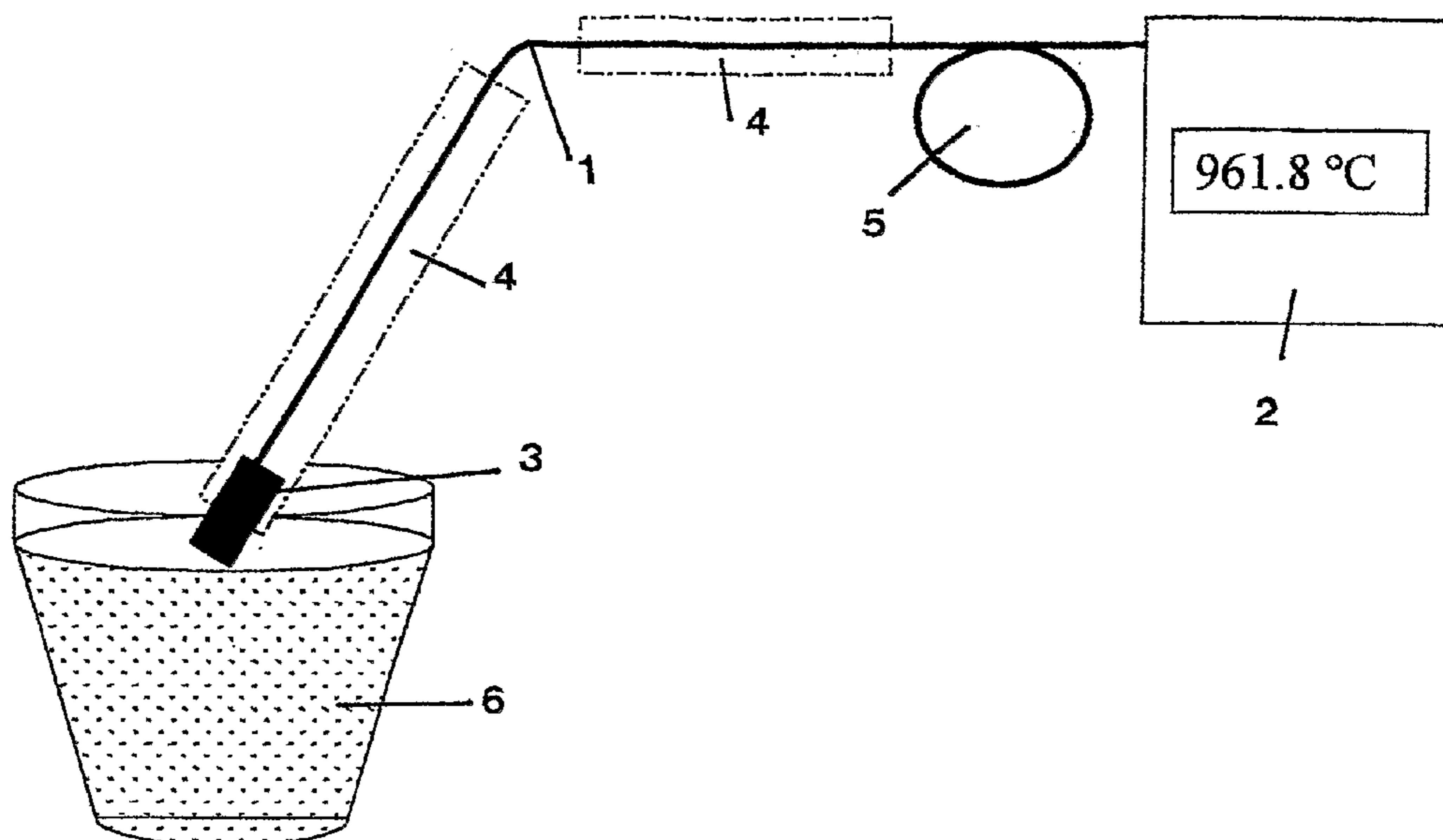
(54) **Title:** ALIGNING AND MEASURING TEMPERATURES IN MELTING BY MEANS OF OPTICAL FIBRES(54) **Bezeichnung:** ABGLEICHEN UND MESSEN VON TEMPERATUREN IN SCHMELZEN MITTELS OPTISCHER FASERN(57) **Abstract:** The invention relates to a method for aligning measuring signals obtainable by means of optical fibres. The inventive method consists in arranging a reference material having a known reference temperature on the end of an optical fibre, heating said reference material to at least the reference temperature thereof, transferring the signal received by the optical fibre at the reference temperature to a measuring instrument in the form of an aligning signal and in comparing said signal with a theoretical reference temperature value, the difference therebetween being used for alignment. A corresponding device and the use thereof for calibrating or determining optical fibre attenuation is also disclosed.

[Fortsetzung auf der nächsten Seite]

WO 2005/005946 A1

**WO 2005/005946 A1**

TN, TR, TT, TZ, UA, UG, US, UZ, VC, VN, YU, ZA, ZM, ZW.

**(84) Bestimmungsstaaten** (soweit nicht anders angegeben, für jede verfügbare regionale Schutzrechtsart): ARIPO (BW, GH, GM, KE, LS, MW, MZ, NA, SD, SL, SZ, TZ, UG, ZM, ZW), eurasisches (AM, AZ, BY, KG, KZ, MD, RU, TJ, TM), europäisches (AT, BE, BG, CH, CY, CZ, DE, DK, EE, ES, FI, FR, GB, GR, HU, IE, IT, LU, MC, NL, PL, PT, RO, SE, SI, SK, TR), OAPI (BF, BJ, CF, CG, CI, CM, GA, GN, GQ, GW, ML, MR, NE, SN, TD, TG).

**Erklärung gemäß Regel 4.17:**

— *Erfindererklärung (Regel 4.17 Ziffer iv) nur für US*

**Veröffentlicht:**

— *mit internationalem Recherchenbericht*

*Zur Erklärung der Zweibuchstaben-Codes und der anderen Abkürzungen wird auf die Erklärungen ("Guidance Notes on Codes and Abbreviations") am Anfang jeder regulären Ausgabe der PCT-Gazette verwiesen.*

---

**(57) Zusammenfassung:** Die Erfindung betrifft ein Verfahren zum Abgleichen von Messsignalen, die mit optischen Fasern erhalten werden und besteht darin, dass ein Referenzmaterial mit einer bekannten Referenztemperatur an einem Ende einer optischen Faser angeordnet wird, dass das Referenzmaterial bis mindestens auf seine Referenztemperatur erwärmt wird, dass das von der Faser bei Erreichen der Referenztemperatur aufgenommene Signal als Abgleichsignal einem Messgerät zugeführt und dort mit dem theoretischen Wert für die Referenztemperatur verglichen und die Differenz zum Abgleichen verwendet wird. Die Erfindung betrifft des weiteren eine entsprechende Vorrichtung sowie die Verwendung zum Kalibrieren oder Bestimmen der Dämpfung einer optischen Faser.

## **Aligning and Measuring Temperatures in Melting By Means of Optical Fibers**

### Technical Field

The invention relates to a method for calibrating measurement signals,  
5 which are obtained with optical fibers, and also to a corresponding measurement device. In addition, the invention relates to a method for measuring the temperature in molten masses (melts) by means of optical fibers, as well as to a measurement device and its use. Here, melts are understood to be both melts of pure metals, such as iron, copper, or steel, or alloys, and also  
10 cryolite melts, salt melts, or glass melts.

### Background of the Invention

Such devices are known, for example, from DE 199 34 299 A1. There, a radiation detector is used for calibrating a measurement system, and a  
15 second radiation detector is used for measuring radiation emitted by a radiation source.

The calibration of temperature sensors is known, for example, from GB 2 155 238 A and from DE 195 32 077 A1. There, a reference material  
20 insulated from a thermoelement tip is used for calibration. This is necessary in order to guarantee problem-free functioning of the thermoelement and to prevent its destruction. Such destructive effects are described, for example, in US 3,499,310. There, it is disclosed explicitly that the thermoelement is protected from chemical reactions with the reference material, for example,  
25 by a coating.

Other devices are disclosed, for example, in JP 63-125906, US 4,576,486, and US 5,364,186.

### Summary of the Invention

The problem of the present invention is to design an improved method for equilibration of measurement signals and a corresponding device for performing the method, which have a simple and reliable function.

5 According to the invention, the problem for the method is solved, in that a reference material with a known reference temperature is arranged at one end of an optical fiber, in that the reference material is heated up to at least its reference temperature, in that the signal received by the fiber, when the reference temperature is reached, is fed as a calibration signal to a measure-  
10 ment device and there compared with the theoretical value for the reference temperature, and the difference is used for calibration. In particular, the end of the optical fiber with the reference material can be immersed in a molten metal, for example, a molten iron or steel, and heated there. In principle, the signal reception proceeds in a known way, wherein particularly, the  
15 calibration signal is converted as a value of an electrical voltage into a temperature value and then compared with the theoretical value for the reference temperature. Here, the reference material is arranged directly at the end of the optical fiber, that is, without the insulation arrangements between the fiber and the reference material, which are necessary according to the  
20 prior art.

The temperature measurement method according to the invention consists in that, after or during a calibration process according to the invention, the optical fiber is immersed in the melt and the obtained optical signal is  
25 evaluated as the value of the temperature of the melt. Due to the closeness in time to the calibration, a high degree of accuracy of the temperature measurement is possible. Before each temperature measurement, calibration

is possible without additional expense. In particular, it is advantageous that the reference temperature of the reference material be less than the melting-point temperature of the melt. It is further useful that the reference material be immersed in the melt to be measured and there be heated up to the  
5 reference temperature of the reference material, and thereafter the temperature of the melt is measured.

It is advantageous that quartz glass and/or sapphire be used as the optical fiber, because in this way, a measurement can be performed in melts at high  
10 temperatures. In addition, it is useful that a combination of a plastic fiber and/or a quartz-glass fiber with sapphire be used as the optical fiber. The combination of a plastic fiber with quartz glass is also possible.

To prevent undercooling of the melt, e.g., during cooling down, the end of  
15 the fiber in contact with the reference material can be set in vibration. The vibration is performed at least intermittently, preferably during cooling down of the melt.

The method according to the invention can be used for calibration or for  
20 determination of the attenuation of the optical fiber.

The reference temperature can be the melting-point temperature of a pure metal, if such a material is used as the reference material. For the use of alloys as the reference material, the liquidus temperature, the solidus  
25 temperature, or the eutectic point, for example, can be used as the reference temperature. According to Plank's law, it is possible to extrapolate calibration curves over greater than 500°C. For example, the calibration with silver

as a reference material can thus be realized at a temperature of 961.8°C, whereby high degrees of accuracy can be reached even for measurements in molten iron at approximately 1550°C.

5 According to the invention, the device for equilibration of measurement signals has an optical fiber, a carrier for the fiber, and a measurement device connected to the optical fiber for receiving a signal output from the optical fiber, and is characterized in that a reference material with a known refer-  
10 ence temperature is arranged (directly) at one end of the optical fiber, and in that the measurement device has a comparator for the signal received from the fiber at the reference temperature of the reference material and supplied to the measurement device as a calibration signal and for a signal corre-  
15 sponding to the theoretical value for the reference temperature, and an evaluation unit is provided for the output and/or processing of the difference for calibration. By the direct arrangement of the reference material at the end of the optical fiber, a high degree of accuracy of the measurement can be achieved with a simple construction.

The problem is solved for a device for measuring a temperature in melts  
20 with optical fibers, in that an equilibration device according to the invention has an immersion end for immersion of the optical fiber in the melt and an evaluation unit for evaluation of the received optical and/or electrical signal as a value for the temperature.

25 For the devices, it is useful that the reference material at least partially cover the end of the optical fiber at least at its end face and/or that the reference material be arranged along the end of the optical fiber, because in this way,

an optimal signal reception is enabled. It is further useful that the end of the optical fiber have at least partially a free surface for receiving radiation. In particular, it is advantageous that the reference material be formed as a compact mass, as a wire, as a wire mesh, or as a tube, and that the optical fiber be formed from quartz glass and/or sapphire. In addition, it can be advantageous that the optical fiber have a combination of a plastic fiber and/or a quartz glass fiber. The combination of a plastic fiber with quartz glass is also possible.

To prevent undercooling of the melt, a vibrator is provided on the optical fiber or its carrier or the fiber guide. The fiber, especially its end in contact with the reference material, can be vibrated with this vibrator.

According to the invention, the device is used for calibration or for determination of the attenuation (thus the propagation losses) of an optical fiber. The term equilibration in this case means calibration or determination of attenuation.

In accordance with one aspect of the present invention, there is provided a method for calibration of measurement signals and for measuring a temperature in a melt by optical fibers, comprising the steps of arranging a reference material with a known reference temperature at one end of an optical fiber, immersing the optical fiber with the reference material at the one end in the melt to be measured to heat the reference material up to at least its reference temperature, wherein the reference temperature of the reference material is less than a melting-point temperature of the melt to be measured, feeding a signal received by the fiber when the reference temperature is

reached as a calibration signal to a measurement device, comparing the signal with a theoretical value for the reference temperature in the measurement device, using any difference from the comparison for calibration, and after the calibration maintaining the optical fiber immersed in the melt to be measured  
5 and evaluating an obtained optical and/or electrical signal as a value of the temperature of the melt.

In accordance with another aspect of the present invention, there is provided a device for equilibration of measurement signals and for measuring a  
10 temperature in a melt by optical fibers, comprising an optical fiber, a carrier for the fiber, a measurement device connected to a first end of the optical fiber for receiving a signal emitted by the optical fiber, a reference material having a known reference temperature arranged at a second end of the optical fiber, the  
15 measurement device having a comparator for the signal received by the fiber at the reference temperature of the reference material and supplied to the measurement device as a calibration signal and for a signal corresponding to a theoretical value for the reference temperature, an evaluation unit for output, processing or output and processing of a difference from the comparator for  
20 calibration and a further evaluation unit for evaluating a received optical signal, electrical signal or optical and electrical signals as a value for the temperature, wherein the second end of the optical fiber is configured for immersion in the melt.

25 In accordance with a further aspect of the present invention, there is provided a method for calibration of measurement signals obtained with optical fibers, comprising the steps of arranging a reference material with a known reference

temperature at one end of an optical fiber, heating the reference material up to at least its reference temperature, feeding a signal received by the fiber when the reference temperature is reached as a calibration signal to a measurement device, comparing the signal with a theoretical value for the reference temperature in the measurement device, using any difference from the comparison for calibration, and further comprising setting the end of the optical fiber into vibration at least intermittently.

In accordance with yet another aspect of the present invention, there is provided a device for equilibration of measurement signals, comprising an optical fiber, a carrier for the fiber, a measurement device connected to a first end of the optical fiber for receiving a signal emitted by the optical fiber, a reference material having a known reference temperature arranged at a second end of the optical fiber, the measurement device having a comparator for the signal received by the fiber at the reference temperature of the reference material and supplied to the measurement device as a calibration signal and for a signal corresponding to a theoretical value for the reference temperature, and an evaluation unit for output processing or output, and processing of a difference from the comparator for calibration, wherein the optical fiber is connected to a vibrator.

#### Brief Description of the Drawings

The invention is explained in more detail below with reference to an embodiment example.

Shown are:

Fig. 1 the schematic view of a measurement arrangement,

Fig. 2 a detailed cross section through the optical fiber,

Fig. 3 a cross section through the immersion end of the measurement or calibration device according to the invention, and

Fig. 4 a measurement curve.

5 Detailed Description of the Preferred Embodiments

An optical fiber 1 is connected at one end to a measurement device 2. The carrier can comprise paperboard or another material, such as steel or ceramic. The measurement device 2 detects the signals led outwards by the optical fiber 1 and is equipped to compare a signal with a theoretical  
10 reference value. In this way, a value generated from a reference material 3, which is arranged at the other end of the optical fiber 1, is compared with a theoretical reference value, for example the reference temperature, stored in the measurement device 2. A possible difference between the two values is used for calibrating the measurement device. Accordingly, the measurement  
15 device 2 includes an evaluation unit for output and/or processing of the data. In the case that a pure metal, for example silver, is used as the reference material 3, the melting-point temperature of the metal, e.g., of silver with 961.8°C, is used as the reference temperature.

20 The optical fiber 1 is held by a carrier 4 and is guided by this carrier. For a freely movable optical fiber 1, it is fed in a loop 5 to the measurement device 2. The reference material 3 arranged at one end of the optical fiber 1 is immersed in a molten metal 6 (for example within a smelting furnace). The molten metal 6 is, for example, molten iron or steel. The reference material 3  
25 is in this case, for example, silver. The reference temperature is the melting-point temperature of the silver. It is less than the melting-point temperature of the molten iron or steel. The end of the optical fiber 1 with the reference

material 3 is immersed in the molten metal 6 with the help of the carrier 4. There, the reference material 3 is first heated to its melting-point temperature. In this way, the signal supplied through the optical fiber 1 to the measurement device 2 is compared with the corresponding theoretical signal value and in this way calibrates the measurement device 2. After the melting of the reference material 3, this heats up further to the actual melting-point temperature of the molten metal 6. The signal led in this way by the optical fiber 1 to the measurement device 2 is evaluated, for example converted into an electric value corresponding to a temperature, and further processed in the measurement device 2. The electric signal can be converted into an optically displayed temperature value. In this way, the measurement device 2 is first calibrated and then the actual temperature of the molten metal 6 is measured. In Figure 4, the temperature profile is plotted during these successive processing steps. Here, the first plateau value that is reached represents the melting-point temperature of the reference material 3 (silver), and the next plateau value represents the temperature of the molten metal 6. A vibration device not shown in the figures is arranged rigidly on the carrier 4. Such vibration devices are known, for example, from DE 44 33 685 A1.

Figure 2 shows a cross section through the end of the optical fiber 1 intended for immersion in a molten metal. The optical fiber 1 has a sleeve (cladding) 7 and a core 8. At its end, the optical fiber 1 is surrounded both laterally and on the end face by the reference material 3. The reference material 3 is held in a manner commonly known to the person skilled in the art. The holding is realized, for example, in the manner shown in Fig. 3, within a quartz tube 9, which is closed on one end and which surrounds the immersion end of the optical fiber 1 with the reference material 3. The optical fiber 1 is here

guided through a ceramic tube 10, for example Alsint. The ceramic tube 10 is fixed by means of cement, for example  $\text{LiSiO}_2$  cement 14 in two further ceramic tubes 11; 12 arranged concentrically. These ceramic tubes can also be formed from Alsint. The ceramic tubes 10; 11; 12 are fixed on a contact  
5 block 13, through which the optical fiber 1 is guided. The contact block 13 is connected to the carrier tube 4 (not shown in Fig. 3). Here, the ceramic tube 12 is fixed in the open end of the carrier tube 4, for example by means of cement. The openings on the end of the ceramic tube 12 are closed with cement 14; 15. Within the ceramic tube 11, cement 16 can also be used for  
10 fixing the elements located therein. The contact block 13 with its connecting piece 17 serves, among other things, also as an optical connection.

### Claims

1. A method for calibration of measurement signals and for measuring a temperature in a melt by optical fibers, comprising the steps of arranging a reference material with a known reference temperature at one end of an optical fiber, immersing the optical fiber with the reference material at the one end in the melt to be measured to heat the reference material up to at least its reference temperature, wherein the reference temperature of the reference material is less than a melting-point temperature of the melt to be measured, feeding a signal received by the fiber when the reference temperature is reached as a calibration signal to a measurement device, comparing the signal with a theoretical value for the reference temperature in the measurement device, using any difference from the comparison for calibration, and after the calibration maintaining the optical fiber immersed in the melt to be measured and evaluating an obtained optical and/or electrical signal as a value of the temperature of the melt.
2. The method according to claim 1, wherein the comparison step comprises converting the calibration signal as a value of an electric voltage into a temperature value and thereafter comparing the temperature value with the theoretical value for the reference temperature.
3. The method according to claim 1 or 2, wherein the optical fiber comprises quartz glass or sapphire.
4. The method according to claim 1 or 2, wherein the optical fiber comprises a combination of sapphire with at least one of a plastic fiber and a quartz-glass fiber.

5. The method according to any one of claims 1 to 4, further comprising setting the end of the optical fiber into vibration at least intermittently.
6. The method according to any one of claims 1 to 5, wherein the calibration comprises determining attenuation of the optical fiber.
7. A device for equilibration of measurement signals and for measuring a temperature in a melt by optical fibers, comprising an optical fiber (1), a carrier (4) for the fiber, a measurement device (2) connected to a first end of the optical fiber for receiving a signal emitted by the optical fiber, a reference material (3) having a known reference temperature arranged at a second end of the optical fiber (1), the measurement device (2) having a comparator for the signal received by the fiber (1) at the reference temperature of the reference material (3) and supplied to the measurement device (2) as a calibration signal and for a signal corresponding to a theoretical value for the reference temperature, an evaluation unit for output, processing or output and processing of a difference from the comparator for calibration and a further evaluation unit for evaluating a received optical signal, electrical signal or optical and electrical signals as a value for the temperature, wherein the second end of the optical fiber (1) is configured for immersion in the melt.
8. The device according to claim 7, wherein the reference material (3) at least partially covers the first end of the optical fiber (1) at least at one of its end face and laterally along the first end of the optical fiber (1).

9. The device according to claim 7 or 8, wherein the first end of the optical fiber (1) has at least partially a free surface.
10. The device according to any one of claims 7 to 9, wherein the reference material (3) has a form selected from a compact mass, a wire, a wire mesh, and a tube.
11. The device according to any one of claims 7 to 10, wherein the optical fiber (1) comprises quartz glass or sapphire.
12. The device according to any one of claims 7 to 10, wherein the optical fiber (1) comprises a combination of sapphire with at least one of a plastic fiber and a quartz-glass fiber.
13. The device according to any one of claims 7 to 12, wherein the optical fiber is connected to a vibrator.
14. The device according to any one of claims 7 to 13, wherein the comparator is adapted for determination of attenuation of the optical fiber.
15. A method for calibration of measurement signals obtained with optical fibers, comprising the steps of arranging a reference material with a known reference temperature at one end of an optical fiber, heating the reference material up to at least its reference temperature, feeding a signal received by the fiber when the reference temperature is reached as a calibration signal to a measurement device, comparing the signal with a theoretical value for the

reference temperature in the measurement device, using any difference from the comparison for calibration, and further comprising setting the end of the optical fiber into vibration at least intermittently.

16. A device for equilibration of measurement signals, comprising an optical fiber (1), a carrier (4) for the fiber, a measurement device (2) connected to a first end of the optical fiber for receiving a signal emitted by the optical fiber, a reference material (3) having a known reference temperature arranged at a second end of the optical fiber (1), the measurement device (2) having a comparator for the signal received by the fiber (1) at the reference temperature of the reference material (3) and supplied to the measurement device (2) as a calibration signal and for a signal corresponding to a theoretical value for the reference temperature, and an evaluation unit for output, processing or output and processing of a difference from the comparator for calibration, wherein the optical fiber is connected to a vibrator.

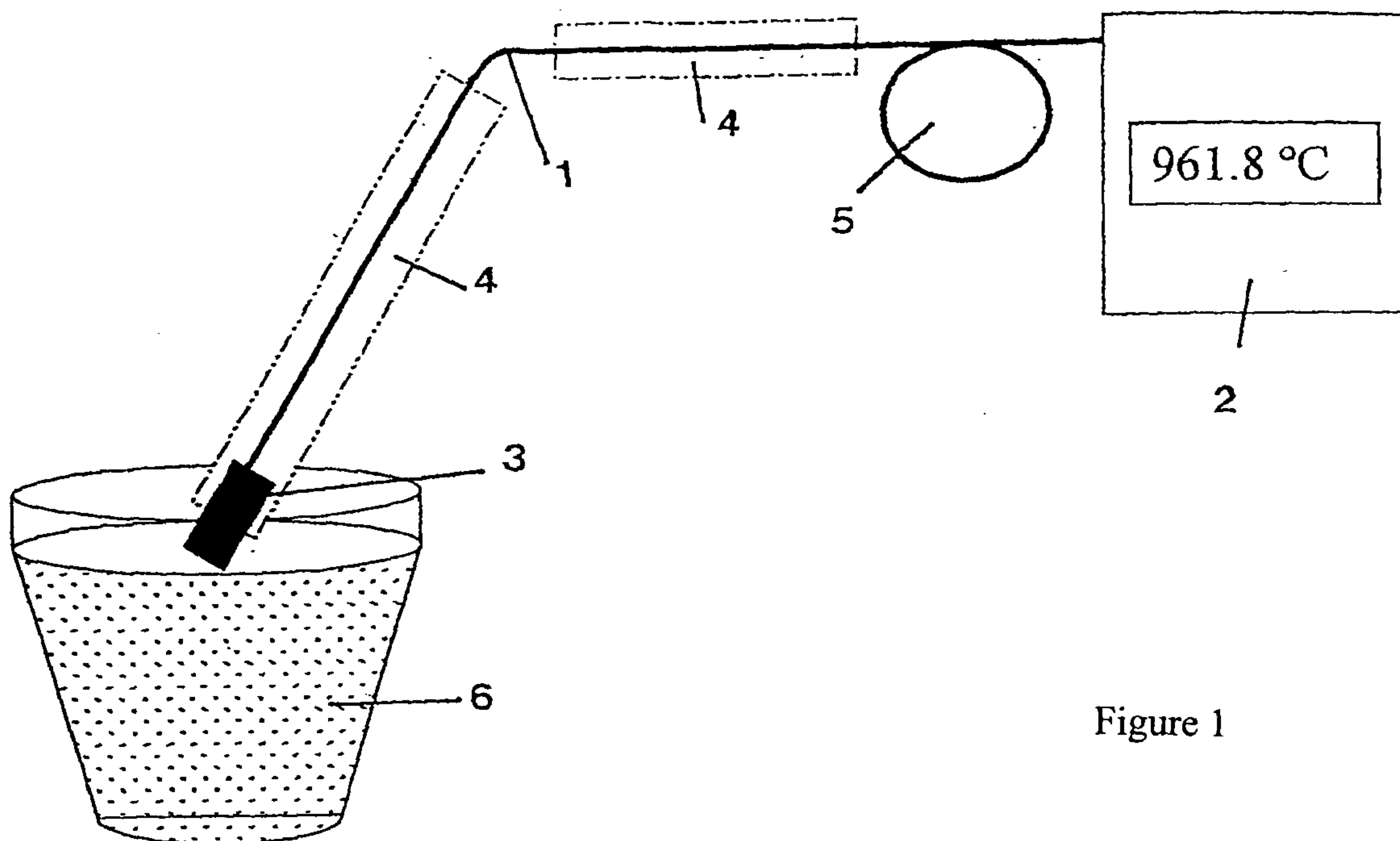

Figure 1

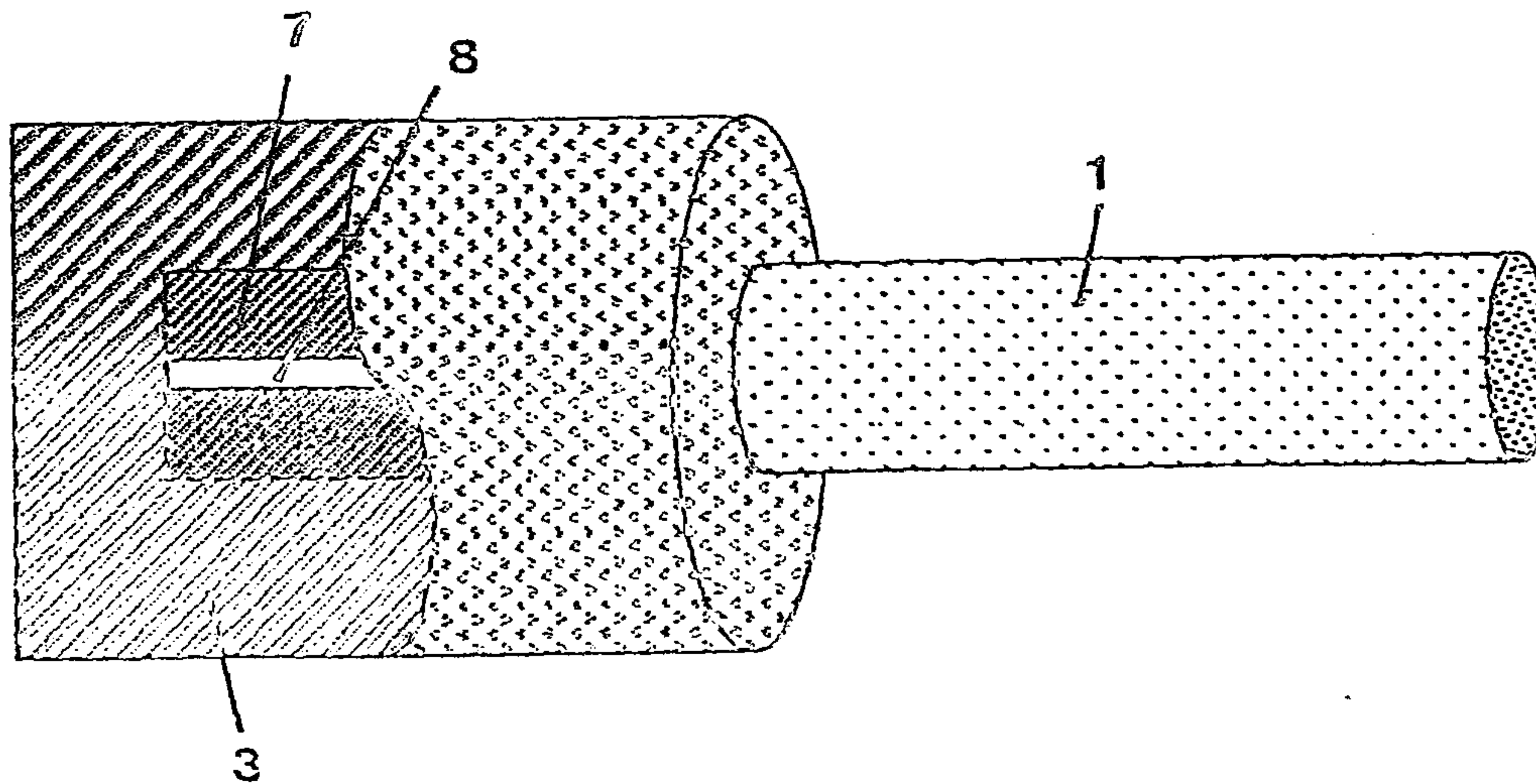

Figure 2

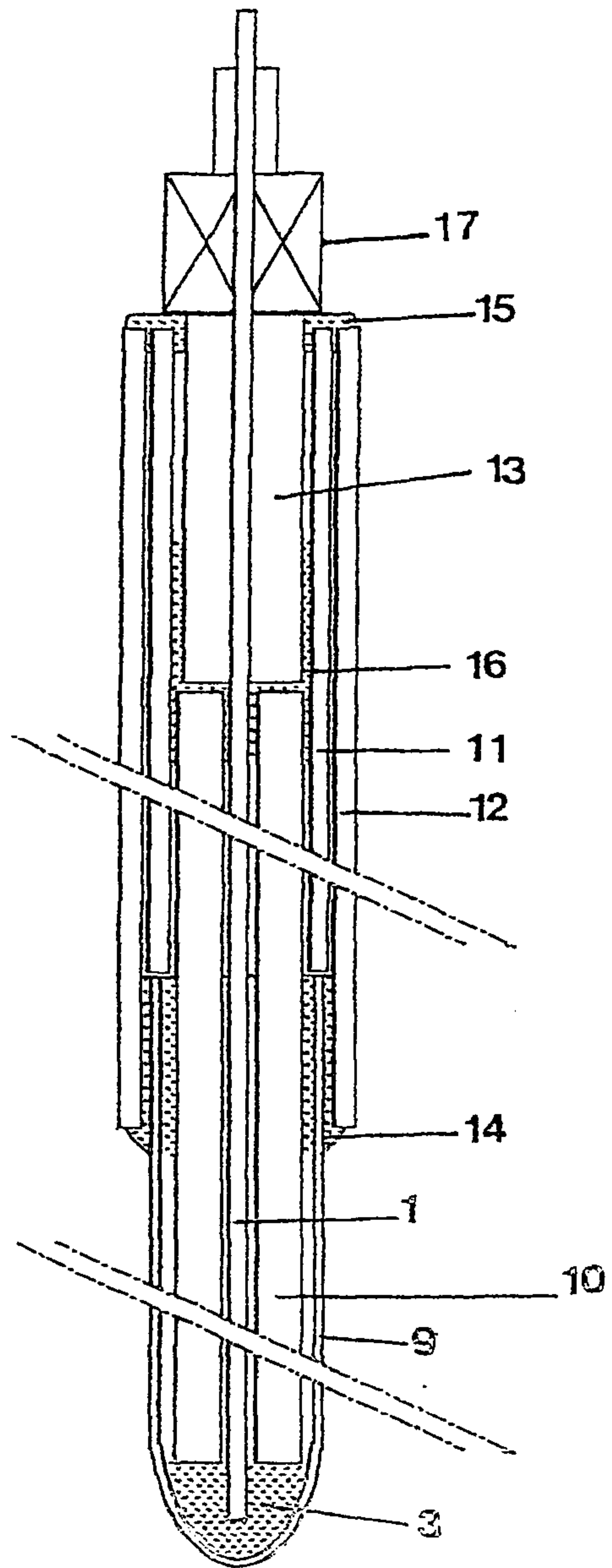

Figure 3

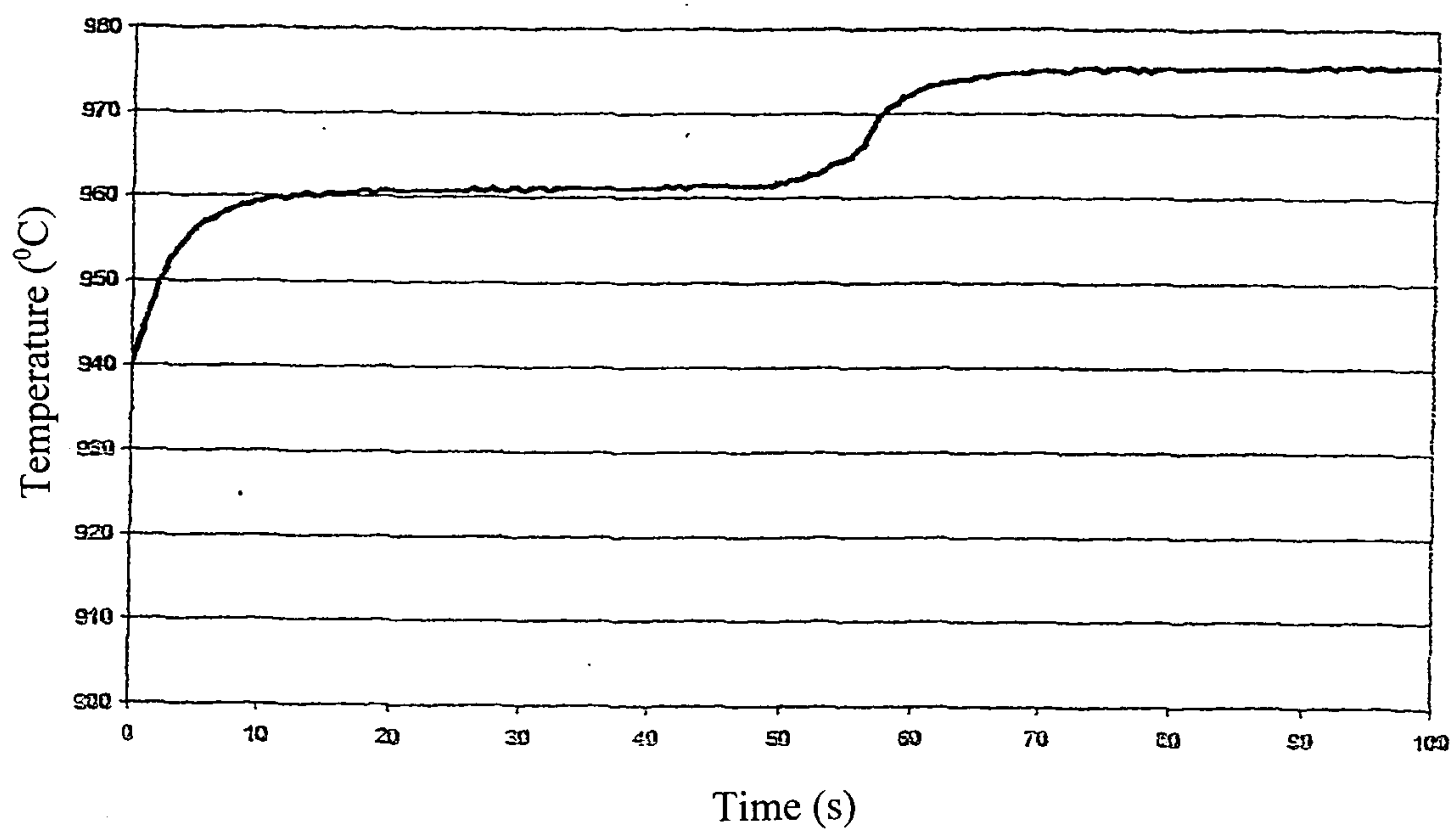

Figure 4

