

18



Europäisches Patentamt
European Patent Office
Office européen des brevets

11 Publication number:

**0 150 132
B1**

12

EUROPEAN PATENT SPECIFICATION

45 Date of publication of patent specification: **17.08.88**

51 Int. Cl.⁴: **H 01 F 29/02, H 01 F 27/14**

21 Application number: **85300443.0**

22 Date of filing: **23.01.85**

54 **On-load tap changer.**

30 Priority: **24.01.84 JP 8515/84**
25.01.84 JP 10514/84

43 Date of publication of application:
31.07.85 Bulletin 85/31

45 Publication of the grant of the patent:
17.08.88 Bulletin 88/33

84 Designated Contracting States:
BE DE GB SE

50 References cited:
EP-A-0 114 648
DE-A-3 240 724

73 Proprietor: **MITSUBISHI DENKI KABUSHIKI
KAISHA**
**2-3, Marunouchi 2-chome Chiyoda-ku
Tokyo 100 (JP)**

72 Inventor: **Yoshida, Kazuo**
14-12, Sakuragaoka Nishi-machi 2-chome Nishi-ku
City of Kobe Hyogo Prefecture (JP)
Inventor: **Miyahara, Tsutomu**
7-52, Shin-mori 1-chome Asahi-ku
City of Osaka Osaka (JP)

74 Representative: **Lawson, David Glynne et al**
MARKS & CLERK 57-60 Lincoln's Inn Fields
London WC2A 3LS (GB)

EP 0 150 132 B1

Note: Within nine months from the publication of the mention of the grant of the European patent, any person may give notice to the European Patent Office of opposition to the European patent granted. Notice of opposition shall be filed in a written reasoned statement. It shall not be deemed to have been filed until the opposition fee has been paid. (Art. 99(1) European patent convention).

Description

This invention relates to an on-load tap changer, and more particularly, to an oil-cleaning system for an oil-filled on-load tap changer.

A diverter switch of a conventional on-load tap changer is basically a switch for switching a load current of a transformer to a preselected tap by the tap selector at zero current. In order to facilitate the extinguishing of an electric arc generated at the time of current commutation, the diverter switch is enclosed within a vessel filled with an electrically insulating oil. The insulating oil is gradually polluted and degraded as it is decomposed to form foreign materials such as carbon and sludge by the electric arcing upon each tap change, thereby degrading the electrically insulating properties. Therefore, the on-load tap changer for use with a high-voltage transformer is provided with an hot-line oil filter, which is a kind of a filter with a pump in it, and the insulating oil is filtered through the oil filter once a day as is well known in the art.

The conduit connecting the vessel for the diverter switch and the oil filter is arranged such that polluted oil at the bottom of the vessel of the tap-changer is suctioned into the conduit and pumped through the oil filter of the oil filter to return to the upper portion of the tap changer vessel. Since the tap changer is typically suspended from the top of the transformer tank, and the oil filter is positioned outside the transformer tank and is placed on the same level as the bottom of the transformer tank. Also, since the suction conduit from which the oil enters for cleaning is typically constructed and incorporated as one of the parts of the tap changer, the conduit rises from the bottom portion of the vessel and extends outwardly through the upper portion of the vessel which is secured to the upper tank of the transformer. Furthermore, since the vessel is suspended from the top plate of the transformer tank, the vessel is usually positioned at a level which is higher than that of the oil filter.

On-load tap changers of this type are described in Japanese Utility Model Publication Nos 36-13315 and 43-13386. In the former, the oil exhaust pipe is disposed within the vessel, and in the latter, the oil exhaust pipe is disposed outside the vessel.

The conventional on-load tap changer thus constructed have the following disadvantageous characteristics.

When insulating oil leaks from the filter or the pump of the oil filter, the insulating oil within the conduits and the vessel flows out through the lead and the oil level within the vessel falls. This lowering of the insulating oil continues until the oil level reaches the level at the inlet of the suction conduit because the conduit has an inverted U-shape which causes the U-shaped conduit to function as a siphon conduit.

Therefore, the oil leakage from the oil filter may cause most of the insulating oil within the tap-changer vessel to flow outside of the system. If

the oil level becomes lower than the interrupting unit, then the arcs will not be extinguished, leading to short-circuits between the taps.

5 SUMMARY OF THE INVENTION

Accordingly, an object of the present invention is to provide an on-load tap changer which is free from the above-mentioned drawback.

10 Another object of the present invention is to provide an on-load tap changer in which there is no risk of most of electrically insulating oil flowing out from the tap changer system.

15 A further object of the present invention is to provide an on-load tap changer in which there is no risk of the level of insulating oil falling due to an oil leak and the interrupting unit of the tap changer being exposed.

20 According to the present invention, there is provided an on-load tap changer comprising a switch including an arc interrupting unit; a vessel containing said switch; an electrically insulating oil disposed within said vessel for electrically insulating said switch; a closed oil passage loop for circulating said insulating oil therealong, said 25 loop including a first conduit having an inlet at the bottom portion of the interior of said vessel, said conduit extending upwardly inside said vessel and exiting from the upper portion of said vessel, extending through a position lower than said 30 vessel and connecting to an upper portion of said vessel, the said loop including an oil filter positioned at the low point of said loop, characterised in that the said conduit has formed therein a hole at a position higher than said arc interrupting unit, 35 said hole being positioned inside said vessel; and a float valve is provided for closing said hole in said conduit when the level of said insulating oil within said vessel is at the same level as or higher than said hole and opening said hole when the level of said insulating oil within said vessel is 40 lower than said hole.

45 According to the present invention, there is also provided an on-load tap changer comprising: a switch including an arc interrupting unit; a vessel containing said switch; an electrically insulating oil disposed within said vessel for electrically insulating said switch; a closed oil passage loop for circulating said insulating oil therealong, said 50 loop including a first conduit having an inlet at the bottom portion of the interior of said vessel, said conduit extending upwardly to a position higher than said arc interrupting unit and then extending to a position lower than said vessel, a second conduit connected to said first conduit to return to an upper portion of said vessel and an oil filter 55 which is positioned at the low point of said loop; characterised in that the first conduit extends outside the vessel, and a pipe having a high flow-resistance connects said first conduit at a position higher than said arc interrupting unit to said 60 second conduit, said pipe having an inside diameter sufficiently smaller than the inner diameter of said first conduit to permit most of said insulating oil supplied into said oil passage loop to be supplied from said inlet of said conduit at 65

the bottom portion of said vessel rather than from said upper portion of said vessel through said pipe.

BRIEF DESCRIPTION OF THE DRAWINGS

The invention will now become more readily apparent from the following detailed description of the preferred embodiment of the present invention taken in conjunction with the accompanying drawings, in which:

Fig. 1 is a diagrammatic view of an on-load tap changer constructed in accordance with the present invention; and

Fig. 2 is a diagrammatic view of an on-load tap changer of another embodiment of the present invention.

An on-load tap changer 10 of the present invention is illustrated in Fig. 1 as being incorporated into an electrical power transformer 12 having a hermetic housing 14. The tap changer 10 comprises a hermetic vessel 16 within which a diverter switch 18 and an arc interrupter unit 20 are enclosed. The vessel 16 has an upper portion 22 and a lower portion 24 in communication with each other. The upper portion 22 of the vessel 16 is placed on the top plate 15 of the transformer housing 14 and the lower portion 24 of the vessel 16 is suspended inside the interior of the transformer housing 14. The diverter switch 18 and the arc interrupting unit 20 are disposed within the lower portion 24 of the vessel 16. Therefore they are positioned within the transformer housing 14, but are isolated by the wall of the vessel 16 from the interior of the transformer housing 14.

The tap changer vessel 16 is substantially filled with an electrically insulating oil 26 in order to promote the quick extinction of the arc generated during tap changing. In order to absorb the volumetric expansion of the insulating oil 26 due to temperature changes, a conservator 28 connected to a breazer 30 by a conduit 32 is connected to the upper portion 22 of the tap-changer vessel 16 through a conduit 34. The tap changer 10 also comprises an oil filter 36 which includes a pump and a filter. It is seen that the bottom wall of the oil filter 36 is positioned at the same level as the bottom wall of the transformer housing 14 and therefore the oil filter 36 is positioned lower than the tap changer 10 which is positioned at the upper portion of the transformer housing 14.

The inlet of the oil filter 36 is connected to the bottom portion of the tap changer vessel 16 by a first conduit 38 having an inlet 40 at the bottom portion inside the tap changer vessel 16. The first conduit 38 has the shape of an inverted "U". This is because the tap changer 10 is typically designed as an assembled unit with at least part of the conduit 38 incorporated into the vessel 16 and it is not desirable to design the walls of the vessel 16 and the transformer housing 14 to be penetrated by the conduit 38. The outlet of the oil filter 36 is connected to the upper portion 22 of the tap changer vessel 16 through a second conduit 42. Thus, a closed oil passage loop 43 composed of the vessel 16, the inverted-U shaped

conduit 38, the oil filter 36, and the second conduit 42 is formed.

According to the present invention, the inverted U-shaped conduit 38 has formed therein an air breazing hole 44 at its top portion. The hole 44 communicates the inside of the conduit 38 to the interior of the upper portion 22 of the tap changer vessel 16. The hole 44 can be closed by a float valve 46 comprising a valve 48 for fluid-tightly closing the hole 44, a rocking lever 50 carrying the valve 48 at its one end and pivotally supported at midpoint 52, and a float 54 supported on the other end of the lever 50. The float valve 46 is closed by the counterclockwise rotational moment on the lever 50 due to the buoyancy of the float 54 when the oil level is higher than a predetermined level, and is opened by the clockwise rotational moment due to the greater weight of the float 54.

In order to clean the insulating oil 26 of the tap changer 10, the pump (not shown) in the oil filter 36 is energized to suction the insulating oil 26 in the bottom portion of the tap changer vessel 16 from the inlet 40. It is to be noted that when the insulating oil 26 fills the upper portion 22 of the vessel 16, the buoyancy of the float 54 presses the valve 48 against the hole 44. Therefore, the insulating oil 26 is supplied into the oil filter 36 only from the inlet 40 at the bottom of the tap changer vessel 16 and no oil passes through the hole 44. The oil 26 supplied through the conduit 38 to the oil filter 36 passes through the filter (not shown) of the oil filter 36 to be cleaned. The filtered oil 26 is returned to the upper portion 22 of the vessel 16 and descend to the bottom portion of the vessel 16. Thus, the insulating oil 26 recirculates through the closed oil passage loop 43 composed of the vessel 16, the inverted U-shaped conduit 38, the oil filter 36, the conduit 42 and again the vessel 16. When the insulating oil 26 has been cleaned, the pump is deenergized.

If an oil leak occurs at the oil filter 36 which is lower than the bottom of the tap changer vessel 16, the insulating oil 26 within the tap changer vessel 16 flows out from the inlet 40 of the conduit 38 through the conduit 38 and from the leak in the oil filter 36. As the oil leak continues, the insulating oil 26 empties first from the conservator 28, and then the level of the insulating oil 26 within the upper portion 22 of the tap changer vessel 16 gradually descends. This gradual descending of the oil level causes the float 54 to also gradually descend due to gravity and when the oil level in the upper portion 22 of the tap changer vessel 16 reaches the hole 44 in the conduit 36, the float 54 cannot provide any force to press the valve 48 against the hole 44, thereby opening the air breazing hole 44 in the first conduit 38. Then, the air introduced within the vessel 16 from the breazer 30 flows into the small hole 44 to prevent the further lowering of the oil level in the tap changer vessel 16 because the insulating oil 26 in the upper portion 22 and the lower portion 24 of the vessel 16 is trapped in the vessel 16. The oil 26 within the section of the conduit 38 to the left of the small hole 44 and the oil in the oil filter 36

flows out through the leak in the filter 36. Therefore, even when an oil leak occurs in the oil filter 36, the insulating oil 26 around the arc interrupting unit 20 in the vessel is maintained.

As has been described, according to the present invention, the oil conduit has formed therein an air breazing hole at a position higher than the interrupting unit, and the hole can be opened by a float valve only when the insulating oil in the vessel is reduced to lower than the level of the hole in the conduit. Therefore, the insulating oil cannot be emptied from the tap changer vessel, thus preventing accidents such as short-circuiting among taps.

Fig. 2 illustrates another embodiment of the present invention, in which a closed oil passage loop 56 of this embodiment is different from the embodiment shown in Fig. 1 in that an inverted-U shaped first conduit 58 shown in Fig. 2 extends outside of the tap changer vessel 16 without passing through the upper portion 22 of the vessel 16. This design is often employed where space for the first conduit is not available within the tap changer vessel 16. The first conduit 58 has an inlet 60 in the bottom portion of the wall of the vessel 16 and extends through the top plate 19 of the tap changer 10. The first conduit 58 is communicated at a position higher than the interrupting unit of the tap changer through a flow resistance pipe 62 with a second conduit 64 having an outlet 65 connecting the oil filter 36 to the upper portion 22 of the vessel 16. The pipe 62 is designed to exhibit a very high flow resistance against the insulating oil 26 flowing therethrough as compared to the flow resistance in the section of the conduit 58 between the inlet 60 and the pipe 62. In the illustrated embodiment, the pipe 62 has a very small inner diameter compared to the inside diameter of the conduit 58.

In this embodiment, since the inner diameter of the pipe 62 is sufficiently small compared to the inside diameter of the first conduit 58, the flow resistance of the small pipe 62 is very high compared to the flow resistance of the flow path in the conduit 58 through the inlet 60. Therefore, most of the insulating oil 26 supplied into the oil filter 36 is supplied from the inlet 60 at the bottom of the tap changer vessel 16 rather than from the upper portion 22 of the vessel 16 through the pipe 62 connected to the outlet end of the second conduit 64. The oil 26 supplied through the conduit 58 to the oil filter 36 passes through the filter (not shown) of the oil filter 36 to be cleaned. The filtered oil 26 is returned through the second conduit 64 to the upper portion 22 of the vessel 16 and descends to the bottom portion of the vessel 16. Thus, the insulating oil 26 recirculates through a closed oil passage loop 56 composed of the vessel 16, the first conduit 58, the oil filter 36, and the second conduit 64. When the insulating oil 26 has been cleaned, the pump is deenergized.

If an oil leak occurs in the oil filter 36 and the oil level in the upper portion 22 of the tap changer vessel 16 reaches the outlet 65 of the second conduit 64 which opens in the side wall of the

upper portion 22 of the vessel 16, air introduced within the vessel 16 from the breazer 30 flows into the interior of the first conduit 58 through the outlet 65 of the second conduit 64 and through the small-diameter pipe 62, preventing further lowering of the oil level in the tap changer vessel 16 because the insulating oil 26 in the upper portion 22 and the lower portion 24 of the vessel 16 is trapped in the vessel 16. The oil 26 within the section of the conduit 38 to the left of the small-diameter pipe 62 and the oil filter 36 flows out through the leak in the filter 36. Therefore, even when an oil leak occurs in the oil filter 36, the insulating oil 26 around the arc interrupting unit 20 in the vessel is maintained.

While the present invention has been described in terms of a tap changer of a particular type, the invention may be equally applicable to on-load tap changer of other types such as a tap selector switch which has the functions of both a tap selector and a diverter switch.

Claims

1. An on-load tap changer comprising:
 - a switch (18) including an arc interrupting unit (20);
 - a vessel (16) containing said switch (18);
 - an electrically insulating oil (26) disposed within said vessel (16) for electrically insulating said switch;
 - a closed oil passage loop (43) for circulating said insulating oil therealong, said loop including a first conduit (38, 42) having an inlet (40) at the bottom portion of the interior of said vessel (16), said conduit extending upwardly inside said vessel and exiting from the upper portion of said vessel, extending through a position lower than said vessel and connecting to an upper portion of said vessel (16), the said loop (43) including an oil filter (36) positioned at the low point of said loop (43), characterised in that the said conduit (38) has formed therein a hole (44) at a position higher than said arc interrupting unit (20), said hole being positioned inside said vessel (16); and a float valve (46) is provided for closing said hole (44) in said conduit (38) when the level of said insulating oil (26) within said vessel (16) is at the same level as or higher than said hole (44) and opening said hole (44) when the level of said insulating oil (26) within said vessel (16) is lower than said hole (44).
2. An on-load tap changer as claimed in claim 1, wherein said switch comprises a diverter switch (18).
3. An on-load tap changer as claimed in claim 1 or 2, wherein said switch comprises a tap selector switch.
4. An on-load tap changer comprising:
 - a switch (18) including an arc interrupting unit (20);
 - a vessel (16) containing said switch (18);
 - an electrically insulating oil (26) disposed within said vessel (16) for electrically insulating said switch;

a closed oil passage loop (56) for circulating said insulating oil therealong, said loop including a first conduit (58) having an inlet (60) at the bottom portion of the interior of said vessel (16), said conduit extending upwardly to a position higher than said arc interrupting unit and then extending to a position lower than said vessel, a second conduit (64) connected to said first conduit (58) to return to an upper portion (22) of said vessel and an oil filter (36) which is positioned at the low point of said loop (56);

characterised in that the first conduit (58) extends outside the vessel (16), and a pipe (62) having a high flow-resistance connects said first conduit (58) at a position higher than said arc interrupting unit (20) to said second conduit (64), said pipe (62) having an inside diameter sufficiently smaller than the inner diameter of said first conduit (58) to permit most of said insulating oil (26) supplied into said oil passage loop (56) to be supplied from said inlet (60) of said conduit (58) at the bottom portion of said vessel rather than from said upper portion (22) of said vessel through said pipe (62).

5. An on-load tap changer as claimed in claim 4, wherein said switch comprises a diverter switch (18).

6. An on-load tap changer as claimed in claim 4 or 5, wherein said switch comprises a tap selector switch.

Patentansprüche

1. Lastschalter, umfassend.

einen Schalter (18), der eine Lichtbogenunterbrechereinheit (20) aufweist;
einen Behälter (16), der den Schalter (18) enthält;

ein elektrisch isolierendes Öl (26), das in dem Behälter (16) vorgesehen ist, um den Schalter elektrisch zu isolieren;

eine geschlossene Öldurchflussschleife (43), um das Isolieröl durch sie hindurch zirkulieren zu lassen, wobei die Schleife eine erste Leitung (38, 42) mit einem Einlaß (40) im Bodenbereich des Innenraumes des Behälters (16) aufweist, die Leitung sich nach oben im Innenraum des Behälters erstreckt und aus dem oberen Bereich des Behälters austritt, sich durch eine Position erstreckt, die niedriger ist als der Behälter, und eine Verbindung mit einem oberen Bereich des Behälters (16) herstellt, wobei die Schleife (43) einen Ölfilter (36) aufweist, der am Tiefpunkt der Schleife (43) angeordnet ist,

dadurch gekennzeichnet, daß in der Leitung (38) ein Loch (44) in einer Position ausgebildet ist, die höher liegt als die Lichtbogenunterbrechereinheit (20), wobei das Loch sich im Innenraum des Behälters (16) befindet;

und daß ein Schwimmentil (46) vorgesehen ist, um das Loch (44) in der Leitung (38) zu schließen, wenn der Pegel des Isolieröls (26) innerhalb des Behälters (16) sich auf dem gleichen oder einem höheren Pegel als das Loch (44) befindet, und um das Loch (44) zu öffnen, wenn

der Pegel des Isolieröls (26) innerhalb des Behälters (16) niedriger ist als das Loch (44).

2. Lastschalter nach Anspruch 1, wobei der Schalter einen Nebenschlußschalter (18) aufweist.

3. Lastschalter nach Anspruch 1 oder 2, wobei der Schalter einen Abgriffwählschalter aufweist.

4. Lastschalter, umfassend:
einen Schalter (18), der eine Lichtbogenunterbrechereinheit (20) aufweist;
einen Behälter (16), der den Schalter (18) enthält;

ein elektrisch isolierendes Öl (26), das innerhalb des Behälters (16) vorgesehen ist, um den Schalter elektrisch zu isolieren;

eine geschlossene Öldurchflussschleife (56), um das Isolieröl durch sie hindurch zirkulieren zu lassen, wobei die Schleife eine erste Leitung (58) mit einem Einlaß (60) im Bodenbereich des Innenraumes des Behälters (16) aufweist, die Leitung sich nach oben in eine Position erstreckt, die höher liegt als die Lichtbogenunterbrechereinheit, und sich dann in eine Position erstreckt, die niedriger liegt als der Behälter, wobei eine zweite Leitung (64) mit der ersten Leitung (58) verbunden ist, die einen Rücklauf zu einem oberen Bereich (22) des Behälters bildet, und ein Ölfilter (36) vorgesehen ist, der am Tiefpunkt der Schleife (56) angeordnet ist,

dadurch gekennzeichnet, daß die erste Leitung (58) außerhalb des Behälters (16) verläuft und eine Leitung (62), die einen hohen Strömungswiderstand hat, die erste Leitung (58) mit der zweiten Leitung (64) in einer Position verbindet, die höher liegt als die Lichtbogenunterbrechereinheit (20), wobei die Leitung (62) einen Innendurchmesser hat, der ausreichend kleiner ist als der Innendurchmesser der ersten Leitung (58), damit das meiste Isolieröl (26), das der Öldurchflussschleife (56) zugeführt wird, von dem Einlaß (60) der Leitung (58) im Bodenbereich des Behälters zugeführt wird, anstatt vom oberen Bereich (22) des Behälters durch die Leitung (62).

5. Lastschalter nach Anspruch 4, wobei der Schalter einen Nebenschlußschalter (18) aufweist.

6. Lastschalter nach Anspruch 4 oder 5, wobei der Schalter einen Abgriffwählschalter aufweist.

Revendications

1. Combinateur de réglage en charge comprenant:

un commutateur (18) comportant une unité d'interruption d'arc (20); un réceptacle (16) renfermant ce commutateur (18); une huile électriquement isolante (26) disposée à l'intérieur de ce réceptacle (16) en vue d'isoler électriquement ce commutateur; une boucle fermée de circulation d'huile (43) en vue d'y faire circuler cette huile isolante, cette boucle comprenant un premier conduit (38, 42) comportant une entrée (40) située dans la partie inférieure de l'intérieur de ce réceptacle (16), ce conduit s'étendant vers le haut à l'intérieur de ce réceptacle et sortant de la partie

supérieure de ce dernier en passant par une position située en dessous de ce dernier, tout en étant relié à une partie supérieure de ce réceptacle (16), cette boucle (43) comprenant un filtre à huile (36) situé au point bas de cette boucle (43), caractérisé en ce que, dans le conduit (38), est pratiqué un trou (44) dans une position supérieure, à celle de l'unité d'interruption d'arc (20), ce trou étant localisé à l'intérieur de ce récipient (16); et en ce qu'une soupape à flotteur (46) est prévue pour fermer ce trou (44) pratiqué dans le conduit (38) lorsque le niveau de l'huile isolante précitée (26) à l'intérieur du réceptacle (16) est le même ou plus élevé que celui auquel est situé ce trou (44), lequel est ouvert lorsque le niveau de l'huile isolante précitée (26) contenue à l'intérieur du réceptacle (16) se situe en dessous du trou précité (44).

2. Combinateur de réglage en charge selon la revendication 1, caractérisé en ce que le commutateur est un commutateur divertisseur (18).

3. Combinateur de réglage en charge selon la revendication 1 ou 2, caractérisé en ce que le commutateur est un commutateur sélecteur à prises.

4. Combinateur de réglage en charge comprenant:

un commutateur (18) comportant une unité d'interruption d'arc (20); un réceptacle (16) renfermant ce commutateur (18); une huile électriquement isolante (26) disposée à l'intérieur de ce réceptacle (16) en vue d'isoler électriquement ce commutateur; une boucle fermée de circulation

d'huile (56) en vue d'y faire circuler cette huile isolante, cette boucle comprenant un premier conduit (58) comportant une entrée (60) à la partie inférieure de l'intérieur du réceptacle (16), ce conduit s'étendant vers le haut jusqu'à une position supérieure à celle de l'unité d'interruption d'arc, puis s'étendant vers une position inférieure à celle du réceptacle, un second conduit (64) raccordé au premier conduit (58) pour revenir à une partie supérieure (22) du réceptacle, ainsi qu'un filtre à huile (36) situé au point bas de la boucle précitée (56), caractérisé en ce que le premier conduit (58) s'étend à l'extérieur du récipient (16), tandis qu'une conduite (62) ayant une haute résistance à l'écoulement raccorde le premier conduit (58) en une position supérieure à celle de l'unité d'interruption d'arc (20) au second conduit (64), cette conduite (62) ayant un diamètre intérieur suffisamment plus petit que le diamètre intérieur du premier conduit (58) pour permettre l'alimentation de la majeure partie de l'huile isolante (26) acheminée dans la boucle de circulation (56), de l'entrée (60) du conduit (58) dans la partie inférieure du récipient plutôt que de la partie supérieure (22) de ce dernier, via la conduite précitée (62).

5. Combinateur de réglage en charge selon la revendication 4, caractérisé en ce que le commutateur est un commutateur divertisseur (18).

6. Combinateur de réglage en charge selon la revendication 4 ou 5, caractérisé en ce que le commutateur est un commutateur sélecteur à prises.

35

40

45

50

55

60

65

6

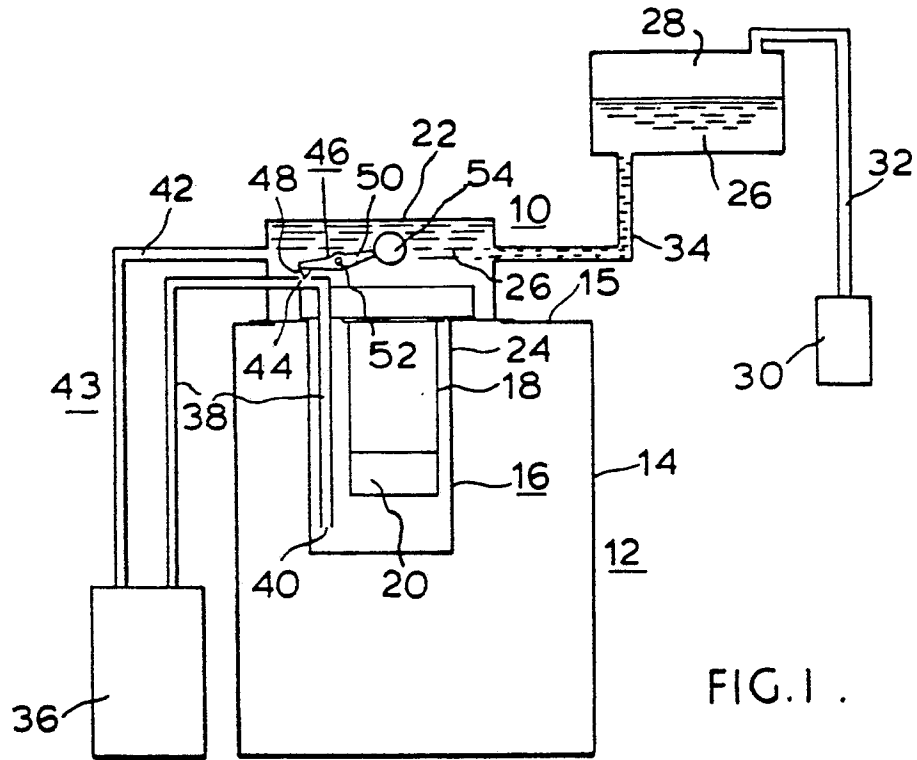

FIG. 1 .

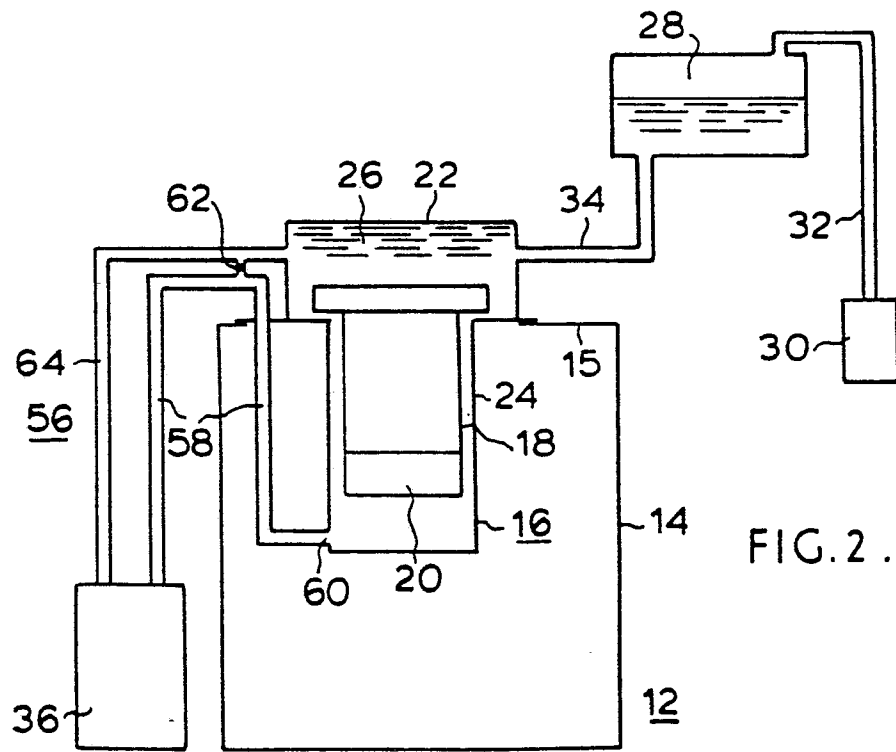

FIG. 2 .