

(19) World Intellectual Property Organization
International Bureau



(43) International Publication Date
13 December 2007 (13.12.2007)

PCT

(10) International Publication Number
WO 2007/143601 A2

(51) International Patent Classification:
H01R 13/52 (2006.01) **H02G 3/08** (2006.01)
H01R 4/36 (2006.01)

(74) Agents: **REGAN, Christopher, F.** et al.; Allen, Dyer, Doppelt, Milbrath & Gilchrist, P.A., 255 S Orange Avenue Suite 1401, Orlando, FL 32801 (US).

(21) International Application Number:
PCT/US2007/070305

(81) Designated States (*unless otherwise indicated, for every kind of national protection available*): AE, AG, AL, AM, AT, AU, AZ, BA, BB, BG, BH, BR, BW, BY, BZ, CA, CN, CO, CR, CU, CZ, DE, DK, DM, DO, DZ, EC, EE, EG, ES, FI, GB, GD, GE, GH, GM, GT, HN, HR, HU, ID, IL, IN, IS, JP, KE, KG, KM, KN, KP, KR, KZ, LA, LC, LK, LR, LS, LT, LU, LY, MA, MD, ME, MG, MK, MN, MW, MX, MY, MZ, NA, NG, NI, NO, NZ, OM, PG, PH, PL, PT, RO, RS, RU, SC, SD, SE, SG, SK, SL, SM, SV, SY, TJ, TM, TN, TR, TT, TZ, UA, UG, US, UZ, VC, VN, ZA, ZM, ZW.

(22) International Filing Date: 4 June 2007 (04.06.2007)

(25) Filing Language: English

(26) Publication Language: English

(30) Priority Data:
60/803,932 5 June 2006 (05.06.2006) US
60/890,368 16 February 2007 (16.02.2007) US

(71) Applicant (*for all designated States except US*): **HOMAC MFG. COMPANY** [US/US]; 12 Southland Road, Ormond Beach, Florida 32174 (US).

(84) Designated States (*unless otherwise indicated, for every kind of regional protection available*): ARIPO (BW, GH, GM, KE, LS, MW, MZ, NA, SD, SL, SZ, TZ, UG, ZM, ZW), Eurasian (AM, AZ, BY, KG, KZ, MD, RU, TJ, TM), European (AT, BE, BG, CH, CY, CZ, DE, DK, EE, ES, FI, FR, GB, GR, HU, IE, IS, IT, LT, LU, LV, MC, MT, NL, PL, PT, RO, SE, SI, SK, TR), OAPI (BF, BJ, CF, CG, CI, CM, GA, GN, GQ, GW, ML, MR, NE, SN, TD, TG).

(72) Inventors; and

(75) Inventors/Applicants (*for US only*): **ELLIOTT, Kenneth, C., III** [US/US]; 179 Ann Rustin Dr., Ormond Beach, Florida 32176 (US). **ZAHNEN, James, L.** [US/US]; 310 Rio Pinar, Ormond Beach, Florida 32174 (US). **CAWOOD, Matthew, D.** [US/US]; 1960 DePaul, De Leon Springs, Florida 32130 (US).

Published:
— *without international search report and to be republished upon receipt of that report*

[Continued on next page]

(54) Title: ELECTRICAL CONNECTOR INCLUDING CABLE END SEALS AND RELATED METHODS

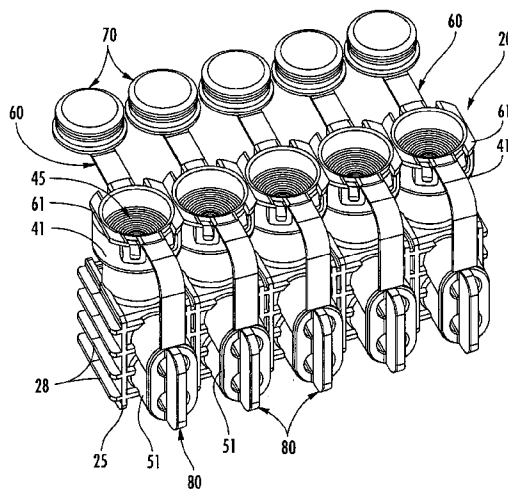

(57) Abstract: An electrical connector for a plurality of electrical cables may include an electrically conductive body having a plurality of spaced apart cable-receiving passageways for receiving respective electrical cable ends therein, and having at least one respective fastener-receiving passageway intersecting each cable-receiving passageway. The connector may also include an insulating cover on the electrically conductive body having a respective cable inlet aligned with each cable-receiving passageway. A respective cable end seal may be associated with each cable inlet. Each cable end seal may include an annular tear stop member including a series of concentric annular ribs, and a nipple coupled to an inner portion of the annular tear stop member so that the nipple is able to seal against smaller diameter electrical cable ends, and so that the annular tear stop member is able to be selectively torn and seal against larger diameter electrical cable ends.

WO 2007/143601 A2



For two-letter codes and other abbreviations, refer to the "Guidance Notes on Codes and Abbreviations" appearing at the beginning of each regular issue of the PCT Gazette.

ELECTRICAL CONNECTOR INCLUDING CABLE END SEALS AND RELATED METHODS

Field of the Invention

[0001] The present invention relates to the field of electrical components, and, more particularly, to an electrical connector for connecting together a plurality of cable ends, and associated methods.

Background of the Invention

[0002] Underground and submersible junction bus connectors are widely used in electrical power distribution systems. One type of such connector is offered under the designation SWEETHEART® by Homac Mfg. Company of Ormond Beach, Fla., the assignee of the present invention. The SWEETHEART® connector is a cast or welded aluminum connector including a bus, or bar, portion and a series of tubular posts extending outwardly from the bus portion. The posts have an open upper end to receive one or more electrical conductors. A threaded bore is provided in the sidewall of the post, and which receives a fastener to secure the electrical conductor within the upper end of the post. An insulating coating is provided on the lower portion of the posts and bus of the connector. In addition, EPDM insulating sleeves may be used to provide waterproof seals for the posts. U.S. Patent Nos. 6,347,966; 6,345,438 and 6,263,567 disclose various embodiments of such bus and post connectors.

[0003] Homac also manufactures a RAB series of "Flood Seal"® Rubberized Aluminum Bar connectors suitable for direct burial, handhole or pedestal applications. The RAB connector includes a generally rectangular aluminum

body having a plurality of spaced apart cable-receiving passageways therein. As the name states, the RAB connector includes a rubber insulating cover over the connector body. The insulating cover includes integrally molded inlets for both the cable-receiving openings and fastener-receiving openings. An insulating boot, such as a cable size adaptor or Rocket may be provided for the cable-receiving inlet, and a sealing cap may be received over the screw in the fastener-receiving inlet.

[0004] U.S. Patent No. 6,688,921 to Borgstrom et al. discloses a connector similar to the Homac RAB series connector. In place of EPDM, the patent uses a thermoplastic elastomer (TPE) that combines the properties of thermoplastic with the performance characteristics of a thermoset rubber. The use of TPE enables the molding to further form sealing plugs attached to the cover with respective tethers. A cable size adaptor is frangibly connected to each sealing plug via an integrally molded web.

[0005] Michaud Electrical Equipment of France offered an insulation displacing connector (IDC) including a generally rectangular connector body, and transverse cable-receiving and fastener-receiving passageways. More particularly, the connector body included a backwall having a pattern of sharp ridges thereon to pierce the insulation on the cable end as the end of the fastener engages and presses against the cable end from the opposite side. To be sure the cable end is fully pressed onto the sharp ridges, a plastic viewing window is provided opposite the inlet of the cable-receiving passageway. Accordingly, an installer can view the cable end to be sure the insulation has been pierced. The window is adjacent the rubber cover. Unfortunately, the Michaud IDC device is likely to leak at the window since the seal is only a mechanical seal. In addition, insulation displacement technology may not be suitable for larger cable sizes with thicker insulation coverings.

[0006] A significant advance in the area of connectors is disclosed in U.S. Patent No. 7,144,279, assigned to Homac Mfg. Company, the assignee of the present invention. The connector includes an electrically conductive body, a thermoplastic elastomer (TPE) insulating cover, and windows aligned with cable

end viewing openings in the conductive body. The electrically conductive body has spaced apart cable-receiving passageways for receiving respective electrical cable ends therein, and with each cable-receiving passageway having a cable inlet opening and a cable end viewing opening opposite the cable inlet opening. The electrically conductive body also has a respective fastener-receiving passageway intersecting each of the cable-receiving passageways. The windows provide a cover and permit visual confirmation of proper placement of the electrical cable end within a corresponding one of the cable-receiving passageways. The electrical connector also includes a respective removable fastener inlet closure cap for each tubular fastener inlet, and a respective flexible tether having a proximal end removably connected adjacent a corresponding tubular fastener inlet and a distal end integrally molded with a corresponding removable fastener inlet closure cap. A respective insulating boot may be received in each of the tubular cable inlets. Each insulating boot may include a tubular sidewall having a progressively increasing diameter to an open outer end thereof, a removable boot closure cap for removable positioning in the open outer end of the tubular sidewall, and an integrally molded tether connecting the removable boot closure cap to the tubular sidewall.

[0007] U.S. Patent No. 7,160,146 to Cawood et al., and assigned to the assignee of the present application, discloses an insulating boot associated with the conductor receiving passageway of an electrical connector. The insulating boot may include an insulating tube, and at least one rupturable seal closing the insulating tube and rupturing upon initial insertion of the cable end therethrough. The rupturable seal may also be compliant to accommodate different sized cable ends and form a seal with adjacent portions of the cable end. A pair of seals may be provided with an optional sealant material therebetween.

[0008] A number of attempts have been made to provide environmental cable end seals for the connectors of the type described above, in particular, to accommodate various size wires and cables that may be advantageously used with such connectors. Unfortunately, such seals have not always provided proper sealing or accommodated sufficiently differently sized wires and cables.

Summary of the Invention

[0009] In view of the foregoing background, it is therefore an object of the present invention to provide an electrical connector with cable end seals that effectively seal and yet still accommodate a wide range of wire and cable sizes, and related methods.

[0010] This and other objects, features, and advantages in accordance with the present invention are provided by an electrical connector for a plurality of electrical cables comprising an electrically conductive body having a plurality of spaced apart cable-receiving passageways for receiving respective electrical cable ends therein. The electrically conductive body may also have at least one respective fastener-receiving passageway intersecting each of the cable-receiving passageways. The electrical connector may further include a respective fastener in each of the fastener-receiving passageways. The electrically conductive body may include an insulating cover having a respective cable inlet aligned with each of the cable-receiving passageways.

[0011] The electrical connector may also include a respective cable end seal associated with each of the cable inlets. Each end seal may comprise an annular tear stop member including a series of concentric annular ribs. The end seal may also include a nipple coupled to an inner portion of the annular tear stop member so that the nipple is able to seal against smaller diameter electrical cable ends, and so that the annular tear stop member is able to be selectively torn and seal against larger diameter electrical cable ends.

[0012] The nipple may depend from the annular tear stop member into a respective cable inlet. The annular tear stop member and the nipple may be integrally molded as a monolithic unit, for example. The cable end seal may further comprise an outer ring-shaped body surrounding an outer portion of the annular tear stop member. The nipple may also comprise a tubular body portion and an end portion coupled thereto. The nipple may still further comprise at least one concentric rib carried by the end portion. A rupturable membrane may be located at a center the nipple in some embodiments. In other embodiments, the

nipple may have an opening at a center thereof. In still other embodiments, the nipple may not be used.

[0013] The cable end seal may comprise a silicone material, for example. The electrical connector may further include a respective fastener in each of the fastener-receiving passageways.

[0014] Another aspect relates to a method for making an electrical connector for a plurality of electrical cables. The method may include forming an electrically conductive body to have a plurality of spaced apart cable-receiving passageways for receiving respective electrical cable ends therein, and having at least one respective fastener-receiving passageway intersecting each cable-receiving passageway. An insulating cover may be positioned on the electrically conductive body and may have a respective cable inlet aligned with each of the cable-receiving passageways. The method may further include forming a respective cable end seal associated with each of the cable inlets as described above.

Brief Description of the Drawings

[0015] FIG. 1 is a front perspective view of an embodiment of an electrical connector in accordance with the present invention.

[0016] FIG. 2 is a rear perspective view of the electrical connector shown in FIG. 1.

[0017] FIG. 3 is a front perspective partially exploded view of the electrical connector shown in FIG. 1.

[0018] FIG. 4 is a side elevational view of the tether assembly of the electrical connector shown in FIG. 1.

[0019] FIG. 5 is a bottom perspective view of the tether assembly shown in FIG. 4.

[0020] FIG. 6 is a cross-sectional view of the electrical connector shown in FIG. 1.

[0021] FIG. 7 is a top perspective view of the cable end seal of the electrical connector shown in FIG. 1.

[0022] FIG. 8 is a side elevational view of the cable end seal shown in FIG. 7.

[0023] FIG. 9 is a bottom perspective view of the cable end seal shown in FIG. 7.

[0024] FIG. 10 is an enlarged cross-sectional view of the cable end seal shown in FIG. 7.

[0025] FIG. 11 is a cross-sectional view of another embodiment of the cable end seal as shown in FIG. 10.

[0026] FIG. 12 is a perspective view of yet another embodiment of a cable end seal according to the present invention.

[0027] FIG. 13 is a top plan view of the cable end seal shown in FIG. 12.

Detailed Description of the Preferred Embodiments

[0028] The present invention will now be described more fully hereinafter with reference to the accompanying drawings in which preferred embodiments of the invention are shown. This invention may, however, be embodied in many different forms and should not be construed as limited to the illustrated embodiments set forth herein. Rather, these embodiments are provided so that this disclosure will be thorough and complete, and will fully convey the scope of the invention to those skilled in the art. Like numbers refer to like elements throughout, and prime and double prime notation are used to indicate similar elements in alternative embodiments.

[0029] Referring now initially to FIGS. 1-6, an electrical connector 20 in accordance with the present invention is described. The electrical connector 20 is for a plurality of electrical cables and illustratively comprises an electrically conductive body 21 (FIG. 6), an insulating cover 25, and a plurality of windows 24 (FIG. 2) aligned with cable end viewing openings 23 (FIG. 6) in the conductive body. The electrically conductive body 21 illustratively has a generally rectangular shape, and may be formed of aluminum, or other conductive material, for example.

[0030] The electrically conductive body 21 also has a plurality of spaced apart cable-receiving passageways 26 each for receiving a respective insulation-free electrical cable end 31 therein (FIG. 6). In the illustrated embodiment of the electrical connector 20, five such passageways 26 are provided, however in other embodiments, more or less than five may be provided as will be

appreciated by those skilled in the art. Of course, not all of the cable-receiving passageways need be used.

[0031] Each cable-receiving passageway 26 has a cable inlet opening 27 and the cable end viewing opening 23 opposite the cable inlet opening (FIG.6). The electrically conductive body 21 also illustratively has a pair of respective fastener-receiving passageways 32 intersecting each cable-receiving passageway 26 (FIG. 6). A respective fastener 33 is also provided in each of the fastener-receiving passageways 32 (FIG. 6). Each of the fasteners 33 may be a hex head fastener with a rounded contacting end, for example. In addition, in other embodiments, only one fastener may be used for each cable end 31 as will be appreciated by those skilled in the art.

[0032] Each electrically insulating transparent viewing window 24 may be positioned adjacent a respective cable end viewing opening 23. The windows 24 thereby provide a cover and permit visual confirmation of proper placement of the insulation-free electrical cable end 31 within a corresponding one of the cable-receiving passageways 26. By transparent is meant that proper positioning of the cable end 31 is visible therethrough. Accordingly, although the window 24 can be fully transparent, transparent is also meant to include partially transparent or translucent where proper seating of the cable end is still viewable.

[0033] The insulating cover 25 on the electrically conductive body 21 also has respective window openings 35 therein aligned with the transparent viewing windows 24 (FIG. 6). The insulating cover 25 may preferably comprise TPE in some embodiments thereby forming an integrally molded bond with adjacent portions of the transparent viewing windows 24 as will be appreciated by those skilled in the art. In other embodiments, the cover 25 may comprise other plastic or rubber insulating materials. Each of the transparent viewing windows 24 may comprise a mounting flange 37 and a lens 38 extending outwardly therefrom. This configuration of the transparent viewing window 24 and through-holes, as contrasted with blind holes, permits the cable end 31 to extend further past the fasteners 33 to thereby result in a more secure connection as will be appreciated by those skilled in the art.

[0034] The mounting flange 37 may be overlapped by adjacent portions of the insulating cover 25. The mounting flange 37 and the lens 38 may be integrally formed as a monolithic unit, for example, such as by molding. Each transparent viewing window 24 may comprise polypropylene to form a strong bond with the TPE of the insulating cover 25. Other similar compatible materials may also be used that are moldable and that form a strong bond to the material of the insulating cover 25. The window 24 may serve to close or seal the cable-receiving passageway 26 during molding of the insulating cover 25. Of course, as will be appreciated by those skilled in the art, the windows 24 may not be needed in other embodiments.

[0035] The insulating cover 25 also illustratively includes an integrally molded respective cable inlet 41 aligned with each of the cable inlet openings 27. Each cable inlet 41 is tubular in shape in the illustrated embodiment, although other shapes are possible as well. The electrical connector 20 may further include a respective cable end seal 45 received in each of the cable inlets 41 as will be described in greater detail below. The insulating cover 25 also illustratively comprises an integrally molded respective dual-port fastener inlet 51 aligned with each of the fastener-receiving passageways 32 (FIG. 6). The fastener inlet 51 is also illustratively tubular, but could have other shapes in other embodiments. In other embodiments a single-port fastener inlet could be provided for use with either a single fastener, or with multiple fasteners. The cover 25 also illustratively includes external ribs 28 that provide additional mechanical protection, facilitate gripping by an installer, provide flow channels during molding, and/or may provide enhanced heat dissipation for the connector 20.

[0036] The electrical connector 20 also includes a plurality of plug tether assemblies 60, the components of which are perhaps best understood with specific reference to FIGS. 4 and 5. The plug tether assembly 60 illustratively includes a base ring 61 received in a snap-fitting engagement on the upper end portion of the cable-receiving inlet 41 (FIG. 3). The base ring 61 carries external locking loops 64 that cooperate with corresponding tabs 65 (FIG. 3) on the cable-receiving inlet 41 to provide the snap-fitting engagement as will be appreciated

by those skilled in the art. In other words, the external locking loops 64 may be considered as providing first snap-fitting features, and the tabs 65 may be considered as providing second snap-fitting features. Of course in other embodiments, the base may have a different shape other than a ring-shape, and different mechanical and/or adhesive approaches may be used to secure the plug tether assembly 60 insulating cover 25 as will also be appreciated by those skilled in the art.

[0037]As perhaps best seen in the exploded view portion of FIG. 3, the base ring 61 is illustratively received within the upper end of the cable inlet 41 and serves to capture the cable end seal 45 in position against the internal shoulder 48 of the cable inlet 41. This arrangement also facilitates manufacturing and assembly of the connector 20 as will be appreciated by those skilled in the art.

[0038]The plug tether assembly 60 illustratively includes a cable inlet plug 70 joined to the base ring 61 via a first flexible tether strap 73. The cable inlet plug 70 illustratively includes a hollow closure cap 71 to be removably received in the cable inlet opening 27, and a gripping member 72 extending from within the closure cap to outside of the cap. The gripping member 72 may be grasped by the installer, either manually or using a suitable tool.

[0039]The plug tether assembly 60 also includes a fastener inlet plug 80 joined to the base ring 61 via a second flexible tether strap 74. The first flexible tether strap 73 and the second flexible tether strap 74 extend outwardly from opposite sides of the base ring 61. The inlet plug 80 illustratively includes two closure caps 83 and an associated gripping member 84. Of course in other embodiments, only a single closure cap 83 may be used. The fastener inlet plug 80 provides selective access to permit tightening of the fasteners 33 and thereafter provides an environmental seal.

[0040]As will be readily appreciated by those skilled in the art, the plug tether assembly 60 may be integrally molded as a unitary body from a suitable material, such as a TPE material or rubber material, for example. The plug tether assemblies 60 may also be made out of two or more grades of TPE, a single grade of TPE, or a TPE and polypropylene, for example. Of course, other

suitable materials may also be used. Accordingly, while the plug tether assemblies 60 facilitate manufacturing, they also keep the plugs 70, 80 and other portions of the connector 20 together so they remain together even when the plugs are not being used or are temporarily removed for access.

[0041] Referring now additionally to FIGS. 7-11, features of the cable end seal 45 are further described. The seal 45 includes an annular tear stop member 49 and an outer ring-shaped body 46 surrounding the outer portion of the annular tear stop member. The annular tear stop member 49 illustratively includes a series of concentric annular ribs 47. The material of the seal 45 is desirably elastic to accommodate different sized wires and/or cables as will be appreciated by those skilled in the art. Depending on the size of the wire or cable end, the tear stop member 49 may be torn out to a concentric ring or rib 47 which then forms a tight seal to the adjacent cable end portions as will be appreciated by those skilled in the art.

[0042] A nipple 48 is illustratively coupled to the inner portion of annular tear stop member. The nipple 48 depends from the annular tear stop 49 into a respective cable inlet 41 as illustrated in FIG. 6, for example. The nipple 48 includes a central opening 50 therethrough in the illustrated embodiments of FIGS. 7-10. In the alternative embodiment of the seal 45' shown in FIG. 11, this opening 50' may be initially closed by a rupturable membrane 54 as will be appreciated by those skilled in the art. Those other elements shown in FIG. 11 are indicated with prime notation and are similar to those described above.

[0043] The nipple 48 also includes a tubular body portion 53 and end portion 52 coupled to the nipple. Illustratively, the nipple 48 includes a concentric rib 55 carried by the end portion 52. More than one concentric rib may be carried by the end portion 52.

[0044] The nipple 48 desirably guides and directs a relatively small gauge wire or cable therethrough and forms an environmental seal thereagainst. For larger cable ends, the nipple 48 may be torn away, or torn partly out of the way, and the cable end will seal against the respective adjacent annular rib 47. In other words, the properly sized rib 47 will serve as a tear stop and seal against the

cable end as will be appreciated by those skilled in the art. This feature permits the concentric ring section to facilitate a range of wire or cable sizes without undue stress. In addition, the seal 45 and the tear stop member 49 may be integrally molded as one piece from a material, such as a silicone material, for example, that provides the desired degree of elasticity or resilience.

[0045] Referring now additionally to FIGS. 12 and 13 yet another embodiment of a cable end seal 45" is now described. In this embodiment there is no nipple, but rather the concentric ribs or rings 47" of the tear stop 49" extend into the central area. The tear stop 49" is carried by the outer ring-shaped body 46". In the illustrated embodiment, the seal 45" has a central opening 50", but in other embodiments the opening may be initially closed by a rupturable membrane as will be appreciated by those skilled in the art.

[0046] A method aspect of the invention is directed to a method for making the electrical connector 20 including forming and attaching a plug tether assembly 60 to each cable inlet 41 as described above. Another method is directed to making the cable seal 45 described above and/or positioning it within the cable inlet 41 as also described above. Of course, other methods are also contemplated by the present invention based upon the connector described herein.

[0047] Other features and advantages in accordance with the invention may be understood with reference to copending application entitled: ELECTRICAL CONNECTOR WITH PLUG TETHER ASSEMBLY AND RELATED METHODS, Attorney Docket No. 64576, the entire contents of which is incorporated herein by reference, as well as in the above-mentioned U.S. Patent Nos. 7,144,279 and 7,160,146, the entire contents of which are incorporated herein by reference. Indeed, many modifications and other embodiments of the invention will come to the mind of one skilled in the art having the benefit of the teachings presented in the foregoing descriptions and the associated drawings. Therefore, it is to be understood that the invention is not to be limited to the specific embodiments disclosed, and that other modifications and embodiments are intended to be included within the scope of the invention.

THAT WHICH IS CLAIMED IS:

1. An electrical connector for a plurality of electrical cables comprising:
 - an electrically conductive body having a plurality of spaced apart cable-receiving passageways for receiving respective electrical cable ends therein, and having at least one respective fastener-receiving passageway intersecting each of the cable-receiving passageways;
 - an insulating cover on said electrically conductive body and having a respective cable inlet aligned with each of the cable-receiving passageways;
 - and
 - a respective cable end seal associated with each of the cable inlets and comprising
 - an annular tear stop member comprising a series of concentric annular ribs, and
 - a nipple coupled to an inner portion of said annular tear stop member so that said nipple is able to seal against smaller diameter electrical cable ends, and so that said annular tear stop member is able to be selectively torn and seal against larger diameter electrical cable ends.
2. The electrical connector according to Claim 1 wherein said nipple depends from said annular tear stop member into a respective cable inlet.
3. The electrical connector according to Claim 1 wherein said annular tear stop member and said nipple are integrally molded as a monolithic unit.
4. The electrical connector according to Claim 1 wherein said cable end seal further comprises an outer ring-shaped body surrounding an outer portion of said annular tear stop member.
5. The electrical connector according to Claim 1 wherein said nipple comprises a tubular body portion and an end portion coupled thereto.

6. The electrical connector according to Claim 5 wherein said nipple further comprises at least one concentric rib carried by said end portion.

7. The electrical connector according to Claim 1 wherein said nipple has a rupturable membrane at a center thereof.

8. The electrical connector according to Claim 1 wherein said nipple has an opening at a center thereof.

9. The electrical connector according to Claim 1 further comprising a respective fastener in each of the fastener-receiving passageways.

10. The electrical connector according to Claim 1 wherein said cable end seal comprises a silicone material.

11. A cable end seal for an electrical connector comprising an electrically conductive body having a plurality of cable-receiving passageways and an insulating cover thereon, the insulating cover having a respective cable inlet aligned with each cable-receiving passageway, the cable end seal comprising:

an annular tear stop member comprising a series of concentric annular ribs; and

a nipple coupled to an inner portion of said annular tear stop member so that said nipple is able to seal against smaller diameter electrical cable ends, and so that said annular tear stop member is able to be selectively torn and seal against larger diameter electrical cable ends.

12. The cable end seal according to Claim 11 wherein said nipple depends from said annular tear stop member into a respective cable-receiving passageway.

13. The cable end seal according to Claim 11 wherein said annular tear stop member and said nipple are integrally molded as a monolithic unit.

14. The cable end seal according to Claim 11 wherein said cable end seal further comprises an outer ring-shaped body surrounding an outer portion of said annular tear stop member.

15. The cable end seal according to Claim 11 wherein said nipple comprises a tubular body portion and an end portion coupled thereto.
16. The cable end seal according to Claim 15 wherein said nipple further comprises at least one concentric rib carried by said end portion.
17. The cable end seal according to Claim 11 wherein said nipple has a rupturable membrane at a center thereof.
18. The cable end seal according to Claim 11 wherein said nipple has an opening at a center thereof.
19. The cable end seal according to Claim 11 wherein said cable end seal comprises a silicone material.
20. An electrical connector for a plurality of electrical cables comprising:
- an electrically conductive body having a plurality of spaced apart cable-receiving passageways for receiving respective electrical cable ends therein, and having at least one respective fastener-receiving passageway intersecting each of the cable-receiving passageways;
 - an insulating cover on said electrically conductive body and having a respective cable inlet aligned with each of the cable-receiving passageways;
 - and
 - a respective cable end seal associated with each of the cable inlets and comprising
 - an annular tear stop member comprising a series of concentric annular ribs so that said annular tear stop member is able to be selectively torn and seal against larger diameter electrical cable ends.
21. The electrical connector according to Claim 20 wherein said cable end seal further comprises an outer ring-shaped body surrounding an outer portion of said annular tear stop member.
22. The electrical connector according to Claim 20 wherein said tear stop member has a rupturable membrane at a center thereof.

23. The electrical connector according to Claim 20 wherein said tear stop member has an opening at a center thereof.

24. The electrical connector according to Claim 20 wherein said cable end seal comprises a silicone material.

25. A cable end seal for an electrical connector comprising an electrically conductive body having a plurality of cable-receiving passageways and an insulating cover thereon, the insulating cover having a respective cable inlet aligned with each cable-receiving passageway, the cable end seal comprising:

an annular tear stop member comprising a series of concentric annular ribs so that said annular tear stop member is able to be selectively torn and seal against larger diameter electrical cable ends; and

an outer ring-shaped body surrounding an outer portion of said annular tear stop member.

26. The cable end seal according to Claim 25 wherein said annular tear stop member and said outer ring-shaped body are integrally molded as a monolithic unit.

27. The cable end seal according to Claim 25 wherein said tear stop member has a rupturable membrane at a center thereof.

28. The cable end seal according to Claim 25 wherein said tear stop member has an opening at a center thereof.

29. The cable end seal according to Claim 25 wherein said cable end seal comprises a silicone material.

30. A method for making an electrical connector for a plurality of electrical cables comprising:

forming an electrically conductive body having a plurality of spaced apart cable-receiving passageways for receiving respective electrical cable ends therein, and having at least one respective fastener-receiving passageway intersecting each of the cable-receiving passageways;

positioning an insulating cover on the electrically conductive body and having a respective cable inlet aligned with each of the cable-receiving passageways; and

forming a respective cable end seal for being associated with each of the cable inlets and comprising

an annular tear stop member comprising a series of concentric annular ribs, and

a nipple coupled to an inner portion of the annular tear stop member so that the nipple is able to seal against smaller diameter electrical cable ends, and so that the annular tear stop member is able to be selectively torn and seal against larger diameter electrical cable ends.

31. The method according to Claim 30 wherein the nipple depends from the annular tear stop member into a respective cable inlet.

32. The method according to Claim 30 wherein the annular tear stop member and the nipple are integrally molded as a monolithic unit.

33. The method according to Claim 30 wherein the cable end seal further comprises an outer ring-shaped body surrounding an outer portion of the annular tear stop member.

34. The method according to Claim 30 wherein the nipple comprises a tubular body portion and an end portion coupled thereto.

35. The method according to Claim 34 wherein the nipple further comprises at least one concentric rib carried by the end portion.

36. The method according to Claim 30 wherein the cable end seal comprises a silicone material.

37. A method for making a cable end seal for an electrical connector comprising an electrically conductive body having a plurality of cable-receiving passageways therein and an insulating cover thereon, the insulating cover having a respective cable inlet aligned with each cable-receiving passageway, the cable end seal comprising:

forming an annular tear stop member comprising a series of concentric annular ribs; and

forming a nipple coupled to an inner portion of the annular tear stop member so that the nipple is able to seal against smaller diameter electrical cable ends, and so that the annular tear stop member is able to be selectively torn and seal against larger diameter electrical cable ends.

38. The method according to Claim 37 wherein the nipple depends from the annular tear stop member into a respective cable inlet.

39. The method according to Claim 37 wherein the annular tear stop member and the nipple are integrally molded as a monolithic unit.

40. The method according to Claim 37 wherein the cable end seal further comprises an outer ring-shaped body surrounding an outer portion of the annular tear stop member.

41. The method according to Claim 37 wherein the nipple comprises a tubular body portion and an end portion coupled thereto.

42. The method according to Claim 41 wherein the nipple further comprises at least one concentric rib carried by the end portion.

43. The method according to Claim 37 wherein the cable end seal comprises a silicone material.

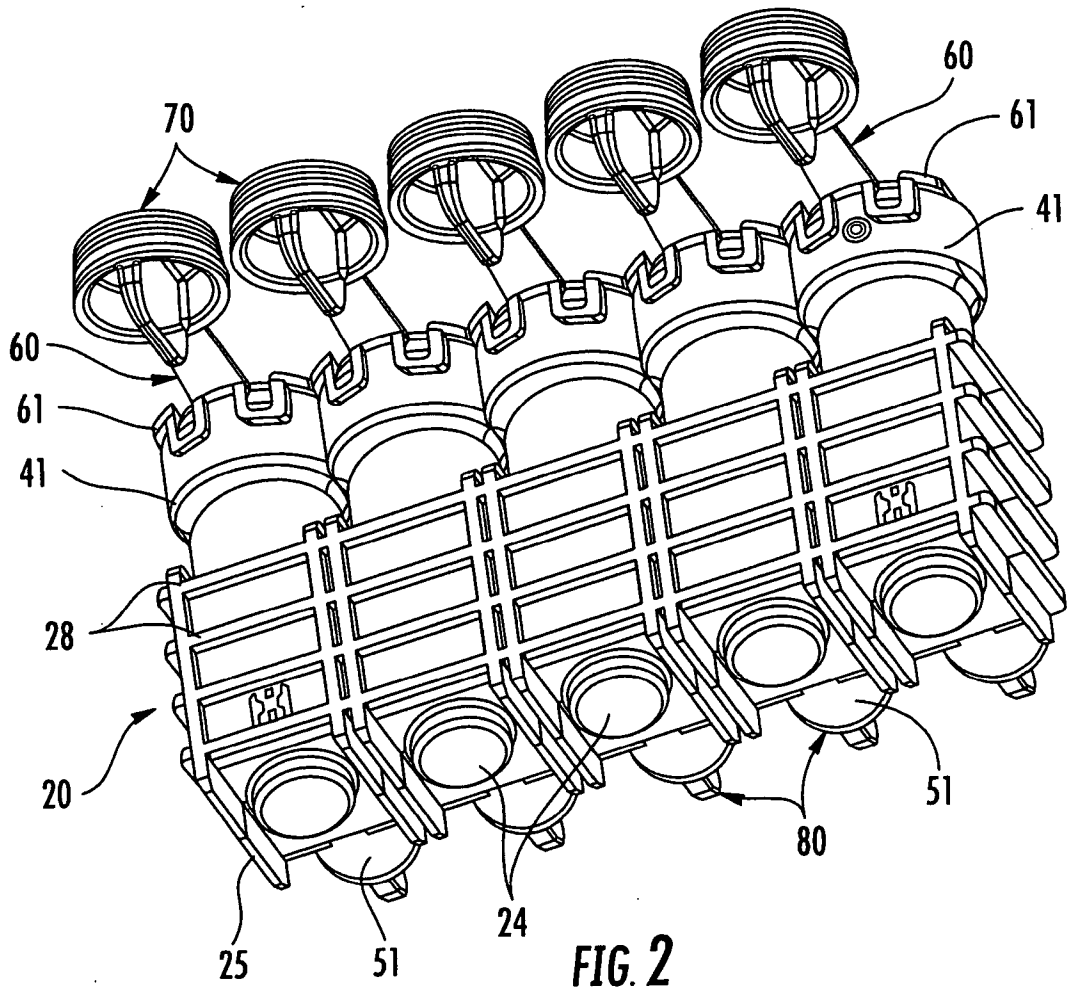

FIG. 2

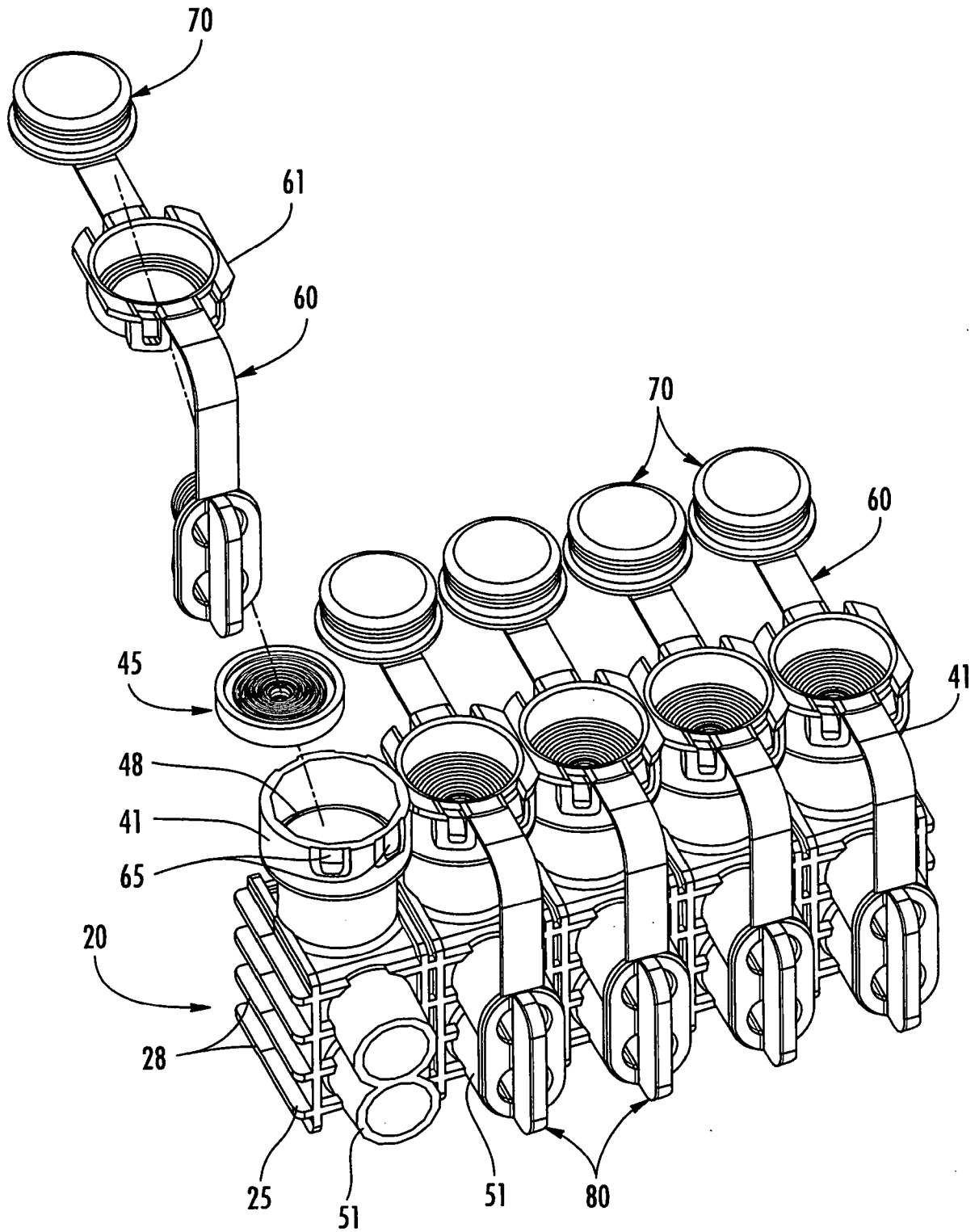
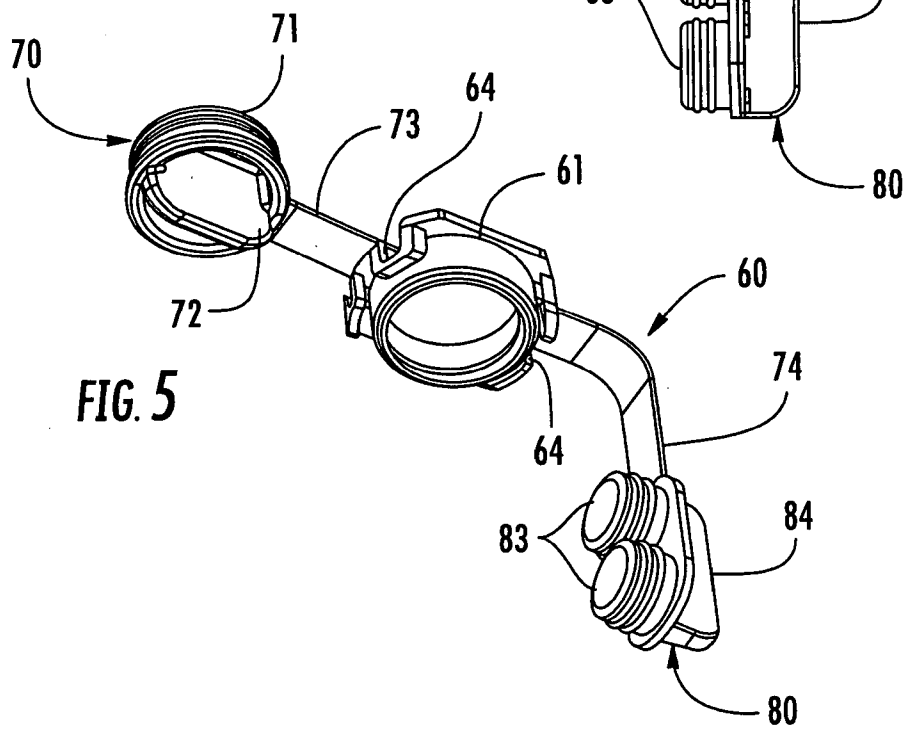
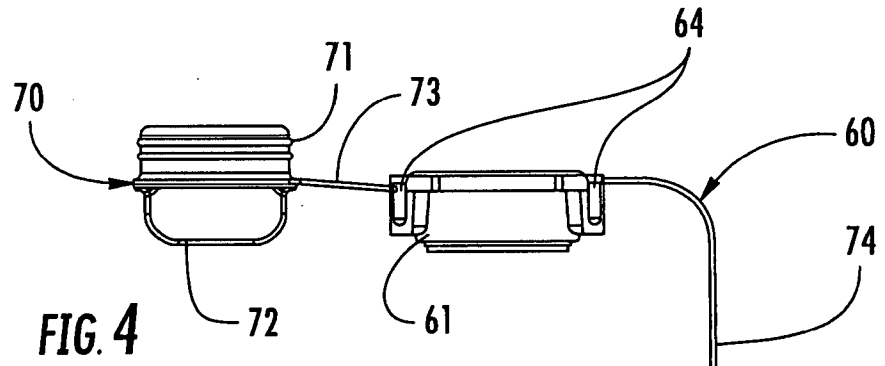

FIG. 3



5/9

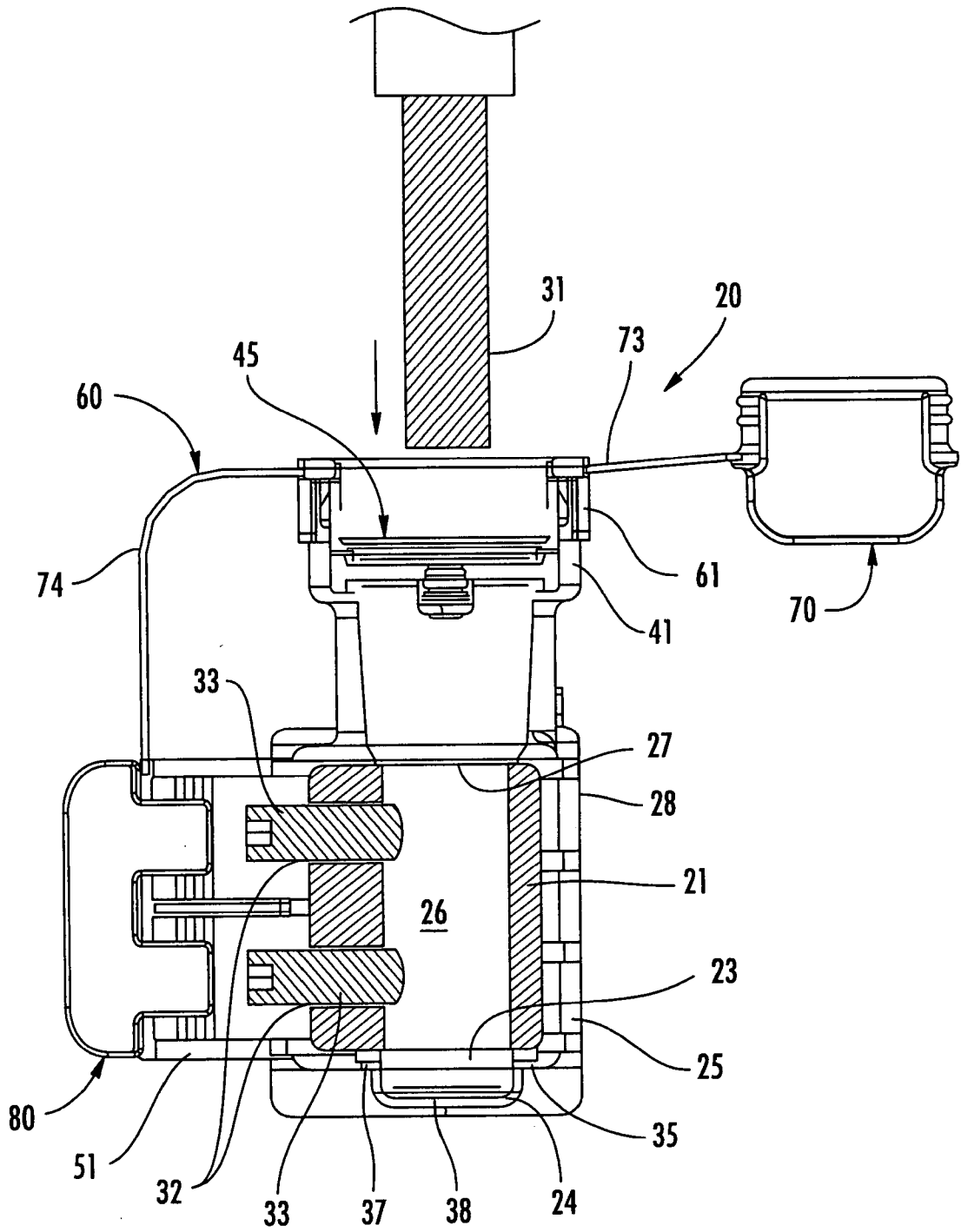
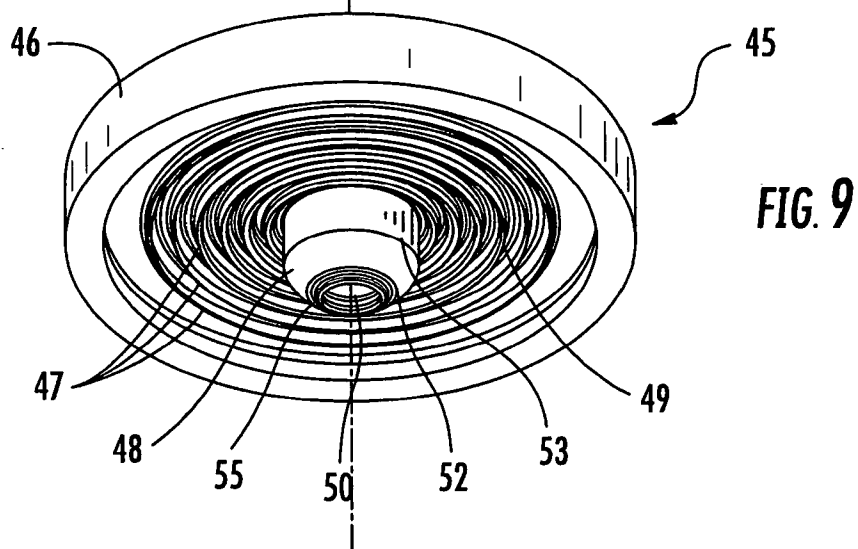
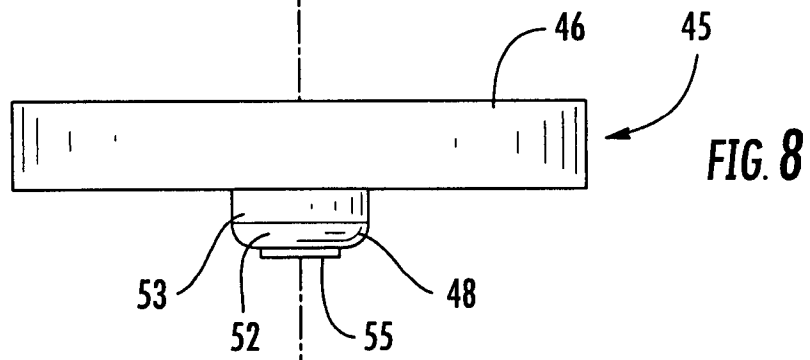
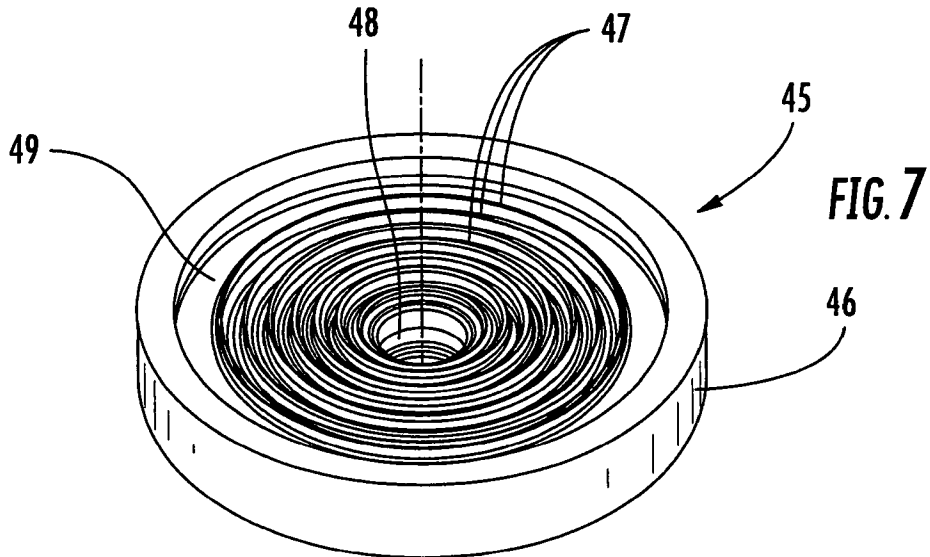
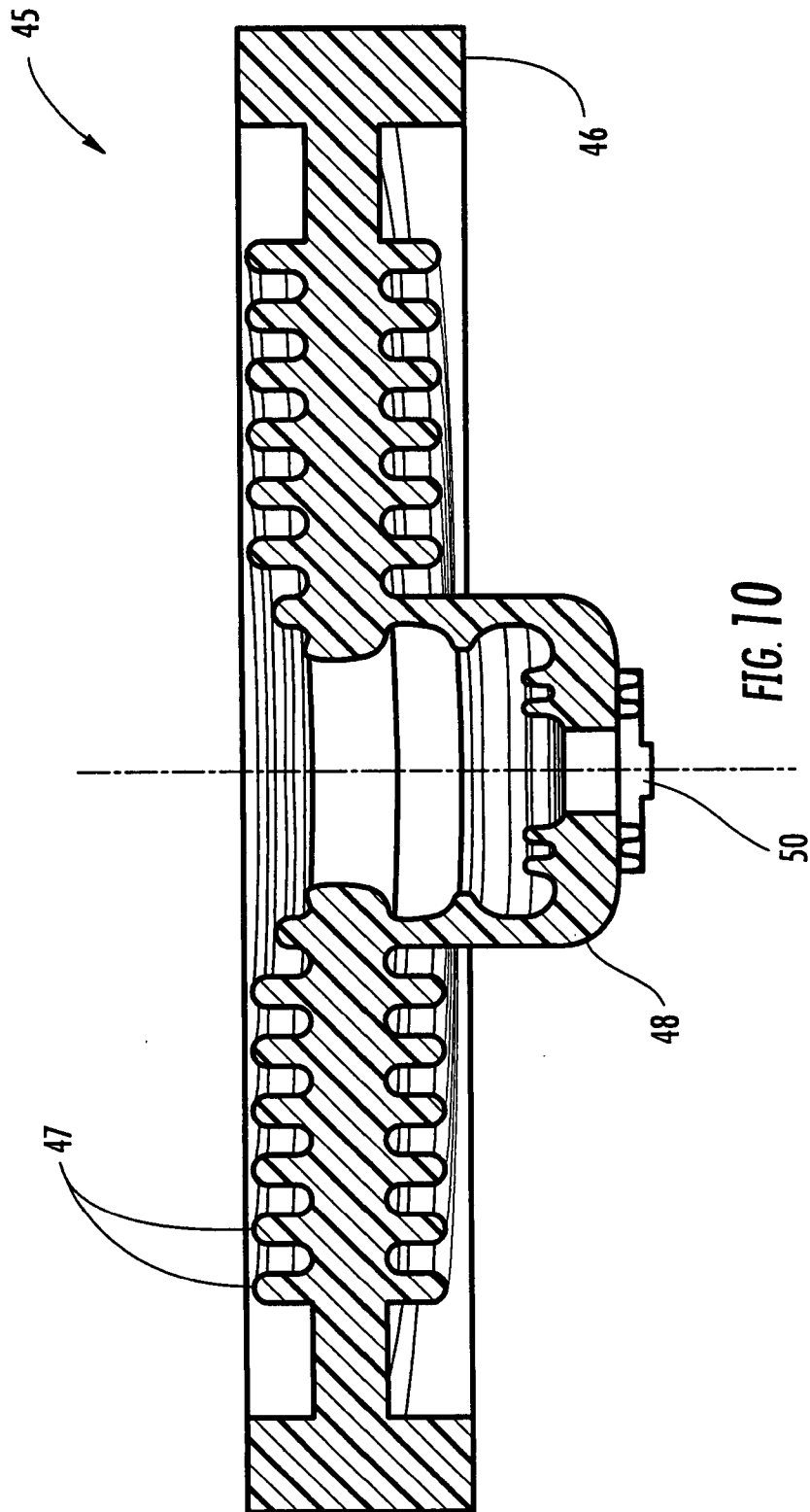

FIG. 6





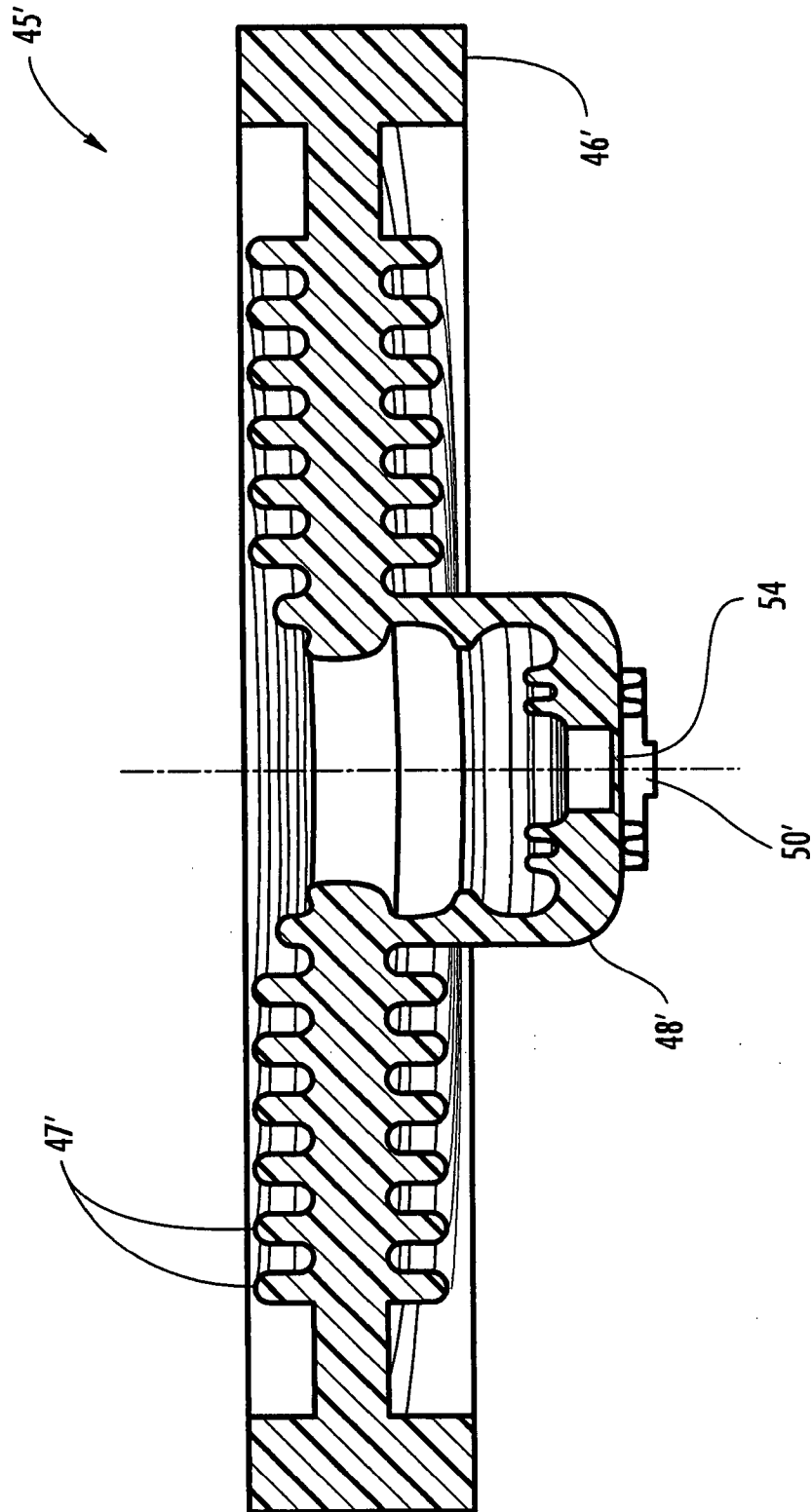

FIG. 11

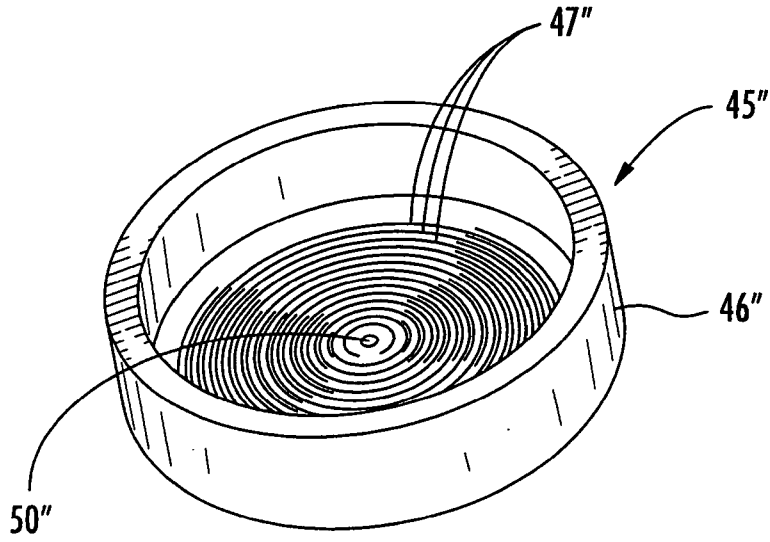

FIG. 12

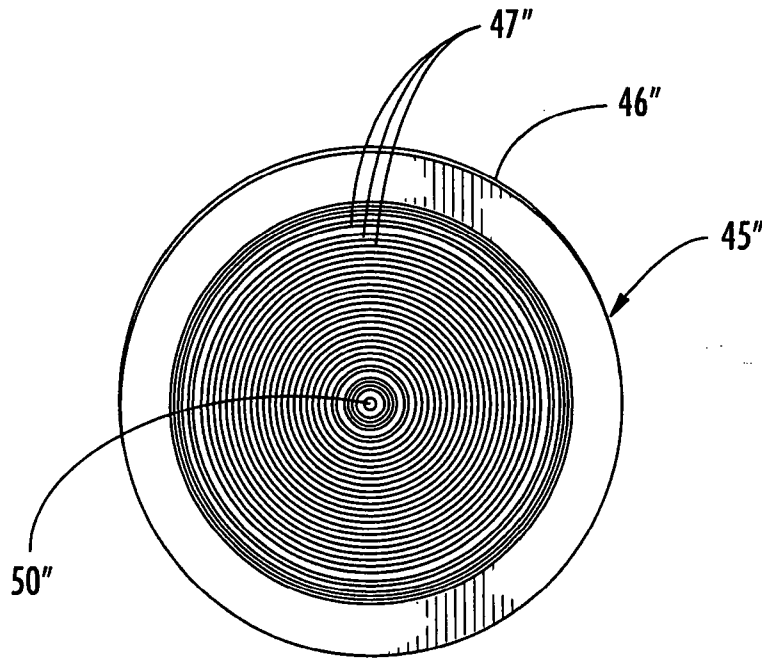

FIG. 13