



(12) **United States Patent**
Measom et al.

(10) **Patent No.:** **US 10,330,322 B2**
(45) **Date of Patent:** **Jun. 25, 2019**

(54) **PELLET FUELED GRILL WITHOUT CLEANOUT PORT**

(71) Applicants: **S. Ty Measom**, Hyde Park, UT (US);
Brett Bennett, Hyde Park, UT (US)

(72) Inventors: **S. Ty Measom**, Hyde Park, UT (US);
Brett Bennett, Hyde Park, UT (US)

(73) Assignee: **LOGAN OUTDOOR PRODUCTS, LLC**, Hyde Park, UT (US)

(*) Notice: Subject to any disclaimer, the term of this patent is extended or adjusted under 35 U.S.C. 154(b) by 127 days.

(21) Appl. No.: **15/491,776**

(22) Filed: **Apr. 19, 2017**

(65) **Prior Publication Data**

US 2017/0219213 A1 Aug. 3, 2017

Related U.S. Application Data

(63) Continuation of application No. 14/329,678, filed on Jul. 11, 2014, now Pat. No. 9,635,978, which is a continuation of application No. 13/345,420, filed on Jan. 6, 2012, now abandoned.

(51) **Int. Cl.**
F24B 13/00 (2006.01)
A47J 37/07 (2006.01)

(52) **U.S. Cl.**
CPC **F24B 13/006** (2013.01); **A47J 37/07** (2013.01); **A47J 37/0704** (2013.01); **A47J 37/0786** (2013.01); **Y10S 16/03** (2013.01); **Y10S 16/24** (2013.01); **Y10S 16/25** (2013.01); **Y10S 16/30** (2013.01); **Y10S 16/32** (2013.01)

(58) **Field of Classification Search**
CPC **F24B 13/006**; **A47J 37/0704**; **A47J 37/07**; **A47J 37/0786**; **Y10S 16/32**; **Y10S 16/24**; **Y10S 16/25**; **Y10S 16/30**; **Y10S 16/03**; **E05B 13/002**; **E05B 13/004**
See application file for complete search history.

(56) **References Cited**

U.S. PATENT DOCUMENTS

2011/0271949 A1* 11/2011 Ortner **A47J 37/0704**
126/25 R

* cited by examiner

Primary Examiner — Alfred Basicas

(74) *Attorney, Agent, or Firm* — Preston P. Frischknecht; Project CIP

(57) **ABSTRACT**

A pellet-fired grill for barbecue cooking includes a cleanout port in the bottom of the combustion chamber and an access door so that the ash may be cleaned out and removed from the grill without necessitating disassembly of the upper components of the grill. The access door is operated by a pull link, and a stop catch mechanism adjacent to the pull link enables actuation of the pull link assembly only when the stop catch mechanism is released.

4 Claims, 5 Drawing Sheets

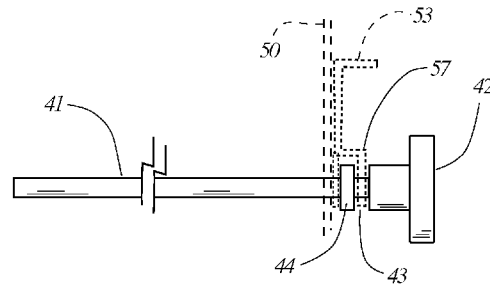
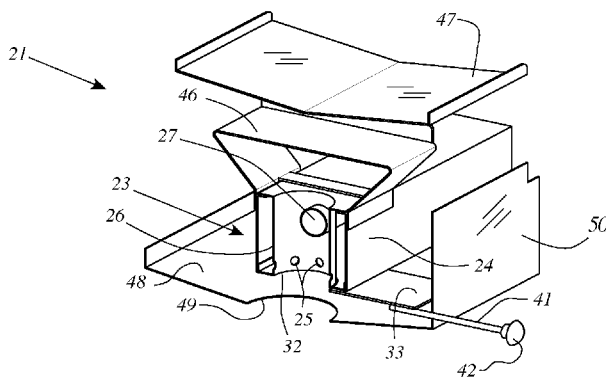

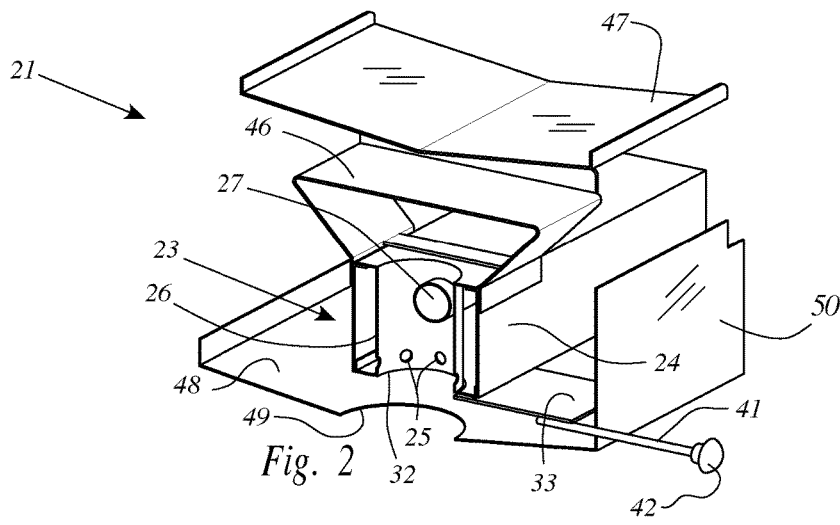
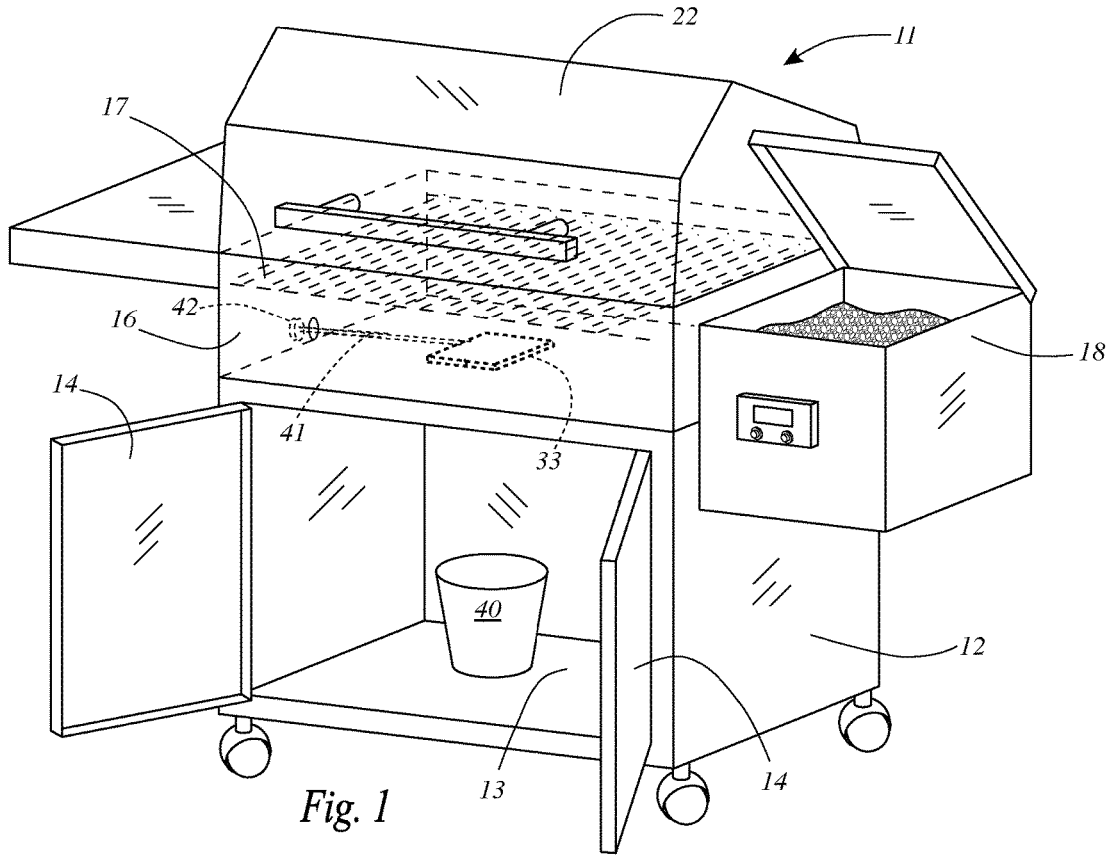

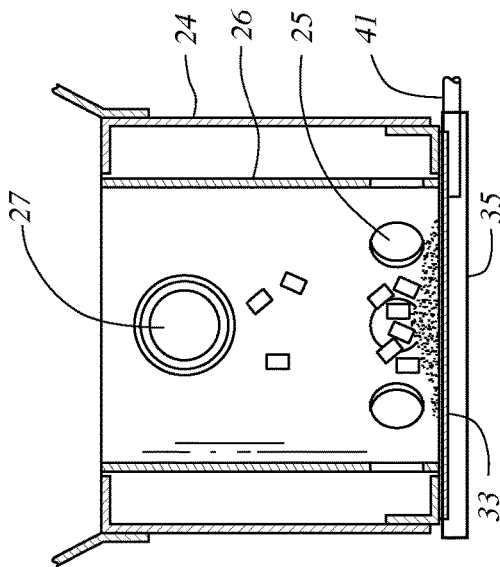

Fig. 3

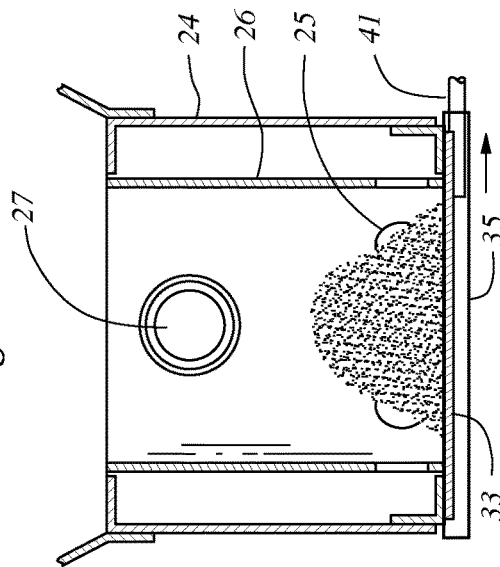

Fig. 4

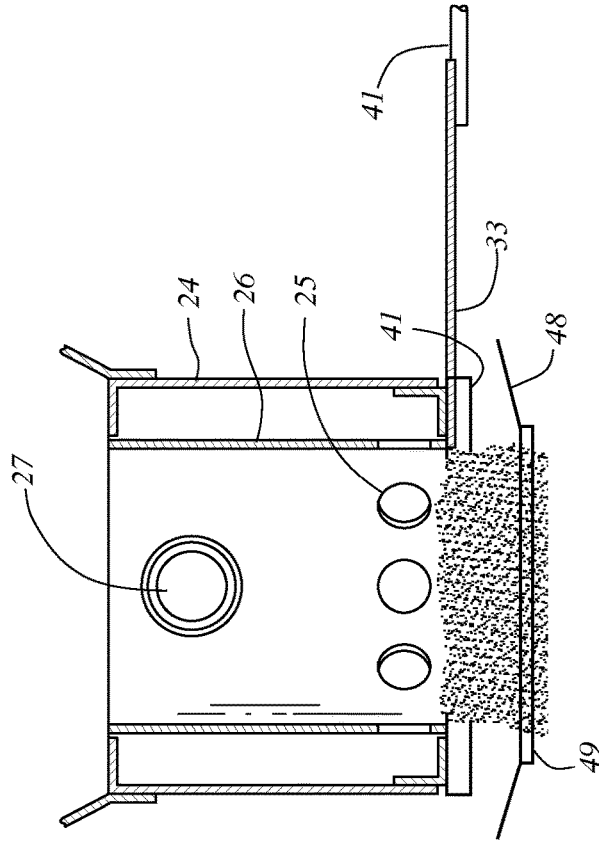
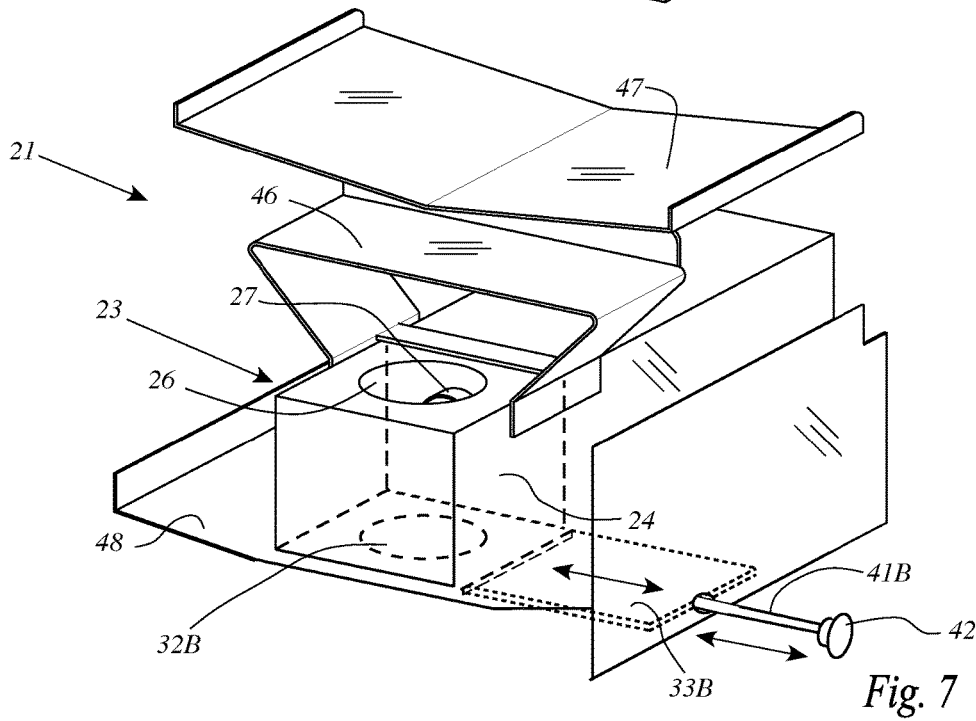
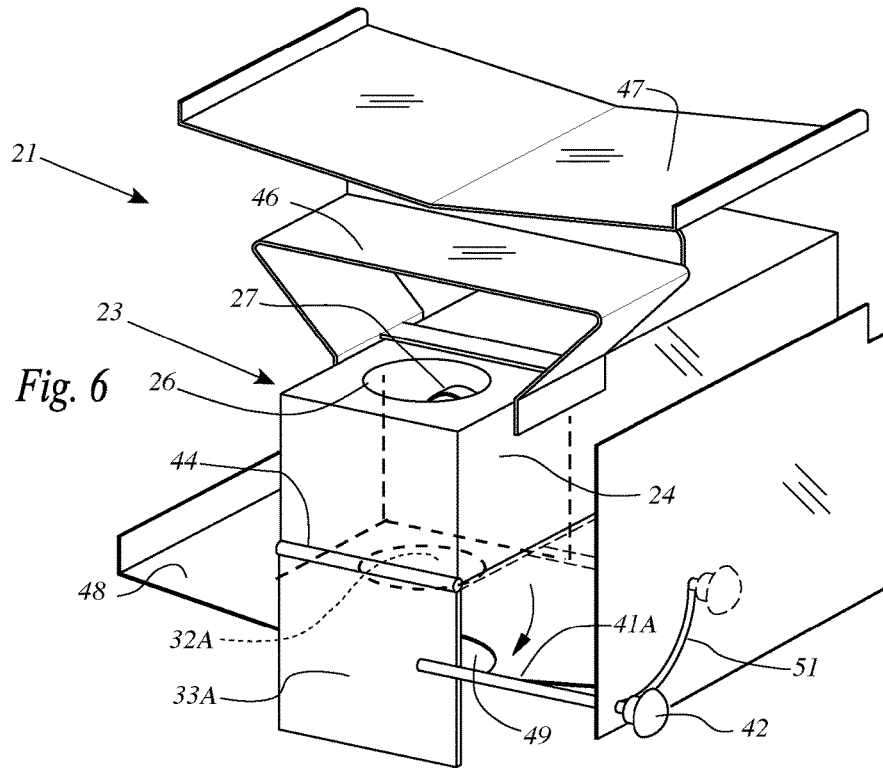

Fig. 5



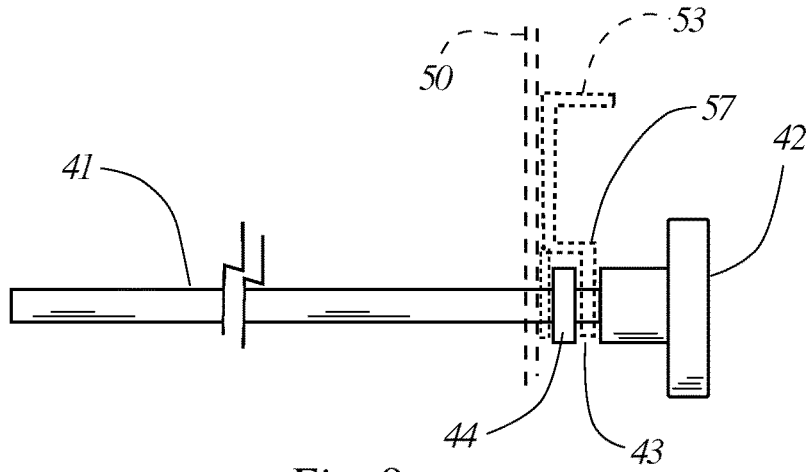

Fig. 8

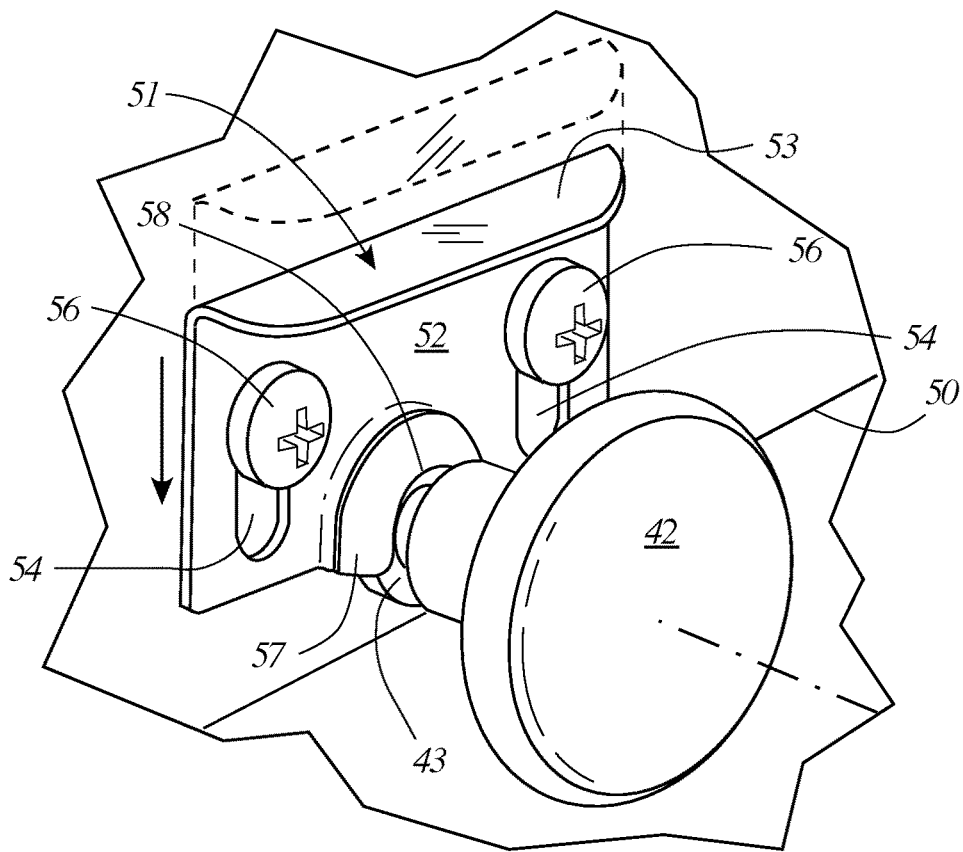

Fig. 9

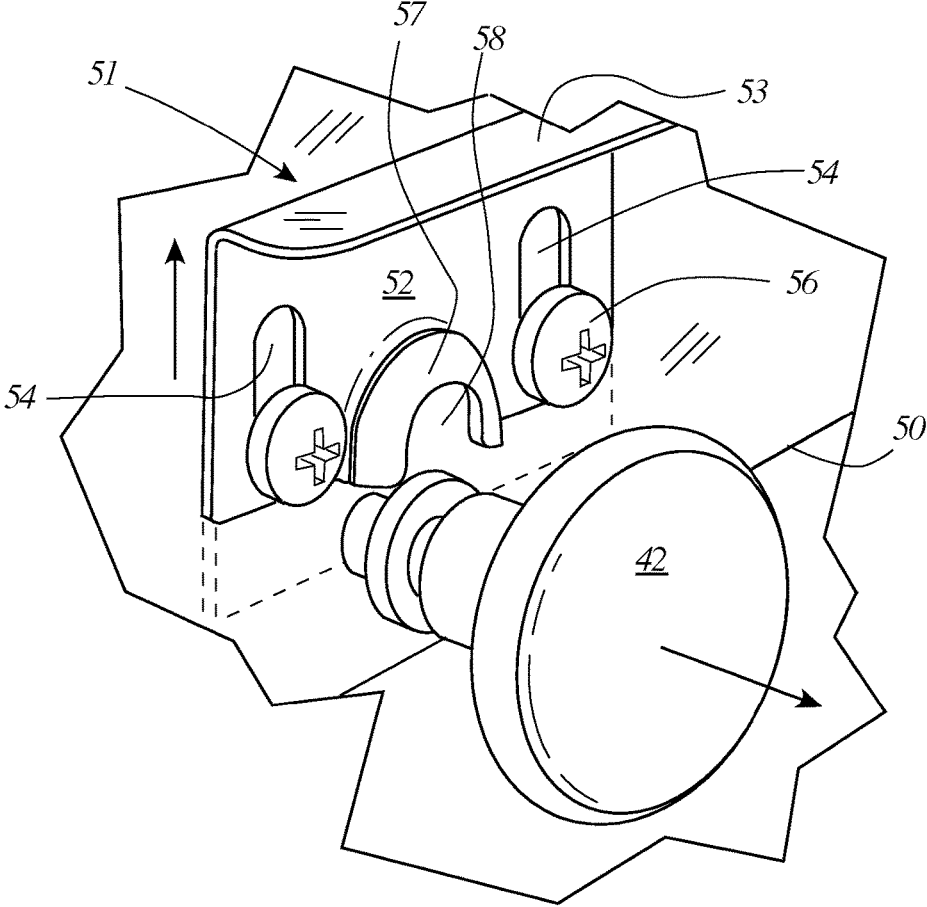

Fig. 10

1

**PELLET FUELED GRILL WITHOUT
CLEANOUT PORT****CROSS-REFERENCE TO RELATED
APPLICATIONS**

This application is a continuation of U.S. application Ser. No. 14/329,678, filed Jul. 11, 2014, which is a continuation-in-part of U.S. application Ser. No. 13/345,420, filed Jan. 6, 2012, from which filing date priority is claimed.

FEDERALLY SPONSORED RESEARCH

Not applicable.

SEQUENCE LISTING, ETC ON CD

Not applicable.

BACKGROUND OF THE INVENTION**Field of the Invention**

This invention relates to barbecue grills and, more particularly, to barbecue grills that are fueled by pelletized wood byproducts.

Description of Related Art

Most barbecue cookers currently in use are fueled by charcoal or charcoal briquettes, or employ gas burners fueled by propane or propane/butane mixtures. However, there are known in the prior art barbecue cookers that employ pelletized wood byproducts as fuel. For example, U.S. Pat. No. 4,823,684 describes a pellet-fired barbecue that is provided with an automatic pellet feeder to sustain the fire and the ongoing cooking task. Starting the fire in the pellet grill is far easier than in a charcoal grill, and the pellet fuel is cheaper than charcoal. Moreover, the amount of fuel consumed is only that which is necessary to complete the cooking task, since the pellet fire extinguishes itself rapidly when the pellet feeder is stopped, whereas charcoal fires tend to burn all the charcoal placed in the grill. And, unlike gas-fired grills, the pellet grill uses wood fuel that produces smoke that flavors the food being cooked on the grill.

However, one of the main problems with existing pellet grills is that the ashes left in the burner after use are difficult to remove. If the accumulated ash is not removed regularly, it may adversely affect the ability to start the pellet burner of the grill. Indeed, the burner should have the ash removed prior to each lighting of the grill.

Prior art pellet-fired grills are not well-constructed to facilitate removal of the ash from the burner unit. Generally, the upper grill components must be disassembled to gain access to the burner. For example, the cooking grates must be removed, an aversive process due to the grease and soot that inevitably coats the grates. Then the heat deflector and flame distributor must be removed to expose the burner unit. The ashes may then be removed, using a vacuum cleaner, and the heat deflector, flame distributor, and cooking grates must be replaced. This is a messy, dirty, and difficult process to undertake every time the grill is used.

BRIEF SUMMARY OF THE INVENTION

The present invention generally comprises a pellet-fired grill for barbecue cooking. A salient feature of the grill is that is provided with a cleanout port in the bottom of the grill that enables access to the ash that falls from the burner unit, so

2

that the ash may be cleaned out and removed from the grill without necessitating disassembly of the upper components of the grill.

The grill is comprised of a base that supports a pan section at a height that is appropriate for the cooking task. The pan section includes one or more cooking grates supported above a pellet burner assembly. The burner assembly typically includes a combustion box that is fed pellet fuel by an auger or other transport arrangement, and a flame distributor disposed above the combustion box to spread the flame generated by the burning fuel. A heat deflector may also be provided, disposed above the flame distributor to spread the heat to the entire grill area. One or more cooking grates are removably disposed above the heat deflector to support food while it is cooked on the grill. Typically, a grill cover is hingedly secured to the pan section to enable open grilling or closed roasting/grilling of comestibles. These enumerated components are typical of prior art pellet-fired cooking grills.

The invention provides an ash cleanout opening in the bottom panel of the pellet burner assembly, and an access door slidably secured adjacent to the cleanout opening. The door may be connected to a knob or pull link so that it may be slidably translated longitudinally to open and close the cleanout opening. In the closed position the access door substantially seals the cleanout opening so that the airflow through the burner assembly is not disrupted from its designed path. When the access door is opened the ash accumulated in the burner may fall out of the burner and be collected. If there is a lower heat deflector or panel of the grill construction, it is provided with an opening directly subjacent to the access door, so that the ash will fall through the subjacent opening and be collected in a bucket or similar container for proper disposal.

In alternative embodiments the access door may be hinged to the bottom of the burner assembly adjacent to the cleanout opening, or may be arranged to pivot about a pin or shaft to open or block the cleanout opening.

A further embodiment of the invention provides a stop catch mechanism that prevents unintended or accidental actuation of the pull link. A sliding bracket is mounted on the grill adjacent to the point where the pull link extends from the grill, the bracket including a clevis-like slot that engages an annular recess provided on the pull link rod adjacent to the outer knob. The bracket must be slidably disengaged from the pull link rod before the knob may be translated to open the access door, thereby eliminating inadvertent opening of the access door.

BRIEF DESCRIPTION OF THE DRAWING

FIG. 1 is a perspective front view of the pellet-fueled grill of the present invention.

FIG. 2 is a cutaway perspective view of the burner assembly of the grill of FIG. 1, showing the access door portion of the invention.

FIG. 3 is a side cross-sectional elevation of the burner assembly of FIG. 2, showing the access door in the closed disposition during combustion.

FIG. 4 is a side cross-sectional elevation of the burner assembly of FIGS. 2 and 3, showing the access door in the closed position with ash accumulation after use.

FIG. 5 is a side cross-sectional elevation of the burner assembly of FIGS. 2-4, showing the access door in the open position for removal of accumulated ash.

3

FIG. 6 is a cutaway perspective view as in FIG. 2, showing a further embodiment of the access door portion of the invention.

FIG. 7 is a cutaway perspective view as in FIGS. 2 and 5, showing another embodiment of the access door portion of the invention.

FIG. 8 is a plan view of a further embodiment of the pull link assembly of the invention.

FIGS. 9 and 10 are enlarged perspective views showing the stop catch mechanism of the invention in the latched and unlatched dispositions, respectively.

DETAILED DESCRIPTION OF THE INVENTION

The present invention generally comprises a pellet-fired grill for barbecue cooking that provides a cleanout port in the bottom of the grill to enable access to the ash that falls from the burner unit, so that the ash may be cleaned out and removed from the grill without necessitating disassembly of the upper components of the grill.

With regard to FIG. 1, the pellet-fired grill 11 employs some components known in the prior art and shown here to elucidate the form and functions of the invention. The grill 11 includes a base 12 having a rectangular solid form and including a storage cupboard 13 behind doors 14. A pan section 16 rests atop the base 12 and houses the heat-generating components of the grill. One or more grates 17 are removably secured at the top of the pan section support food items being grilled. A supply bin 18 of pellet fuel is disposed adjacent to the pan section 16, and a pellet transport device such as an auger is disposed between the bin 18 and a pellet burner assembly 21. A grill cover 22 is hinged at one edge to the pan section 16 to enable open grill cooking as well as closed grill roasting.

With reference to FIG. 2, the pellet burner assembly 21 generally includes a combustion chamber 23 secured within a coffer-like housing 24. Supported on the housing 24 is a lower heat deflector 46 and, above that, the upper heat deflector 47. A bottom heat deflector 48 is spaced below the combustion chamber 23, and is provided with a bottom opening 49 extending therethrough. The combustion chamber 23 includes a cup 26 that receives the pellets of fuel delivered by a transport mechanism to an auger tube or chute 27, whereby the pellets to be directed by the chute 27 into the cup 26, where they are burned. Note that combustion air is blown through the housing 24, which feeds air through holes 25 in the cup 26 to burn the pellets therein. The combustion chamber 23 has an open top and a bottom opening 32, with an access door 33 disposed at its bottom end in sealing fashion, so that pellets of fuel are retained and burned in the cup 26 during operation of the grill, as shown in FIG. 3. Over time the combustion process generates ash that forms in the cup 26 and tends to collect therein, as shown in FIG. 4.

The access door 33 includes opposed longitudinal sides, and the bottom of the combustion chamber 23 includes supports 35 (FIGS. 3-5) that engage the longitudinal sides and enable the door to translate longitudinally in slidable fashion. The door 33 is dimensioned to span the width of opening 32 so that the opening is entirely occluded and blocked. Note that the opening 32 in the bottom of the combustion chamber 23 is aligned with the opening 49 in the bottom heat deflector 48.

A pull link 41 is connected to the door 33 and disposed to extend longitudinally. The link 41 protrudes from the front or side or back of the grill assembly, and terminates in a

4

handle or knob 42. The knob 42 enable a user to slide the door in the longitudinal direction out of its blocking position in opening 32. When the door is pulled free of the opening 32 the ash that has accumulated in the cup 26 is free to fall through the opening 32 and through the opening 49 in the bottom heat deflector, to be collected in a disposal container such as bucket 40 (FIG. 1). The door 33 is translated inwardly to reclose the slot opening. This closure preserves the combustion air flow pattern within the combustion chamber. The opening 32 may also be used to admit a vacuum intake hose from a vacuum cleaning device to positively remove the ash from the combustion chamber 23 and holes 25.

With regard to FIG. 6, there is shown a further embodiment in which the components of the burner assembly 21 are substantially similar to those of FIGS. 2-5 and are accorded the same reference numerals. In this embodiment the access door 33A is secured to the housing 24 by hinge 44, so that the door 33A may pivot open as explained previously to remove accumulated ash, and to pivot closed to block opening 32A. The hinged door 33A is connected to a link 41A which extends longitudinally through the front panel of the grill and through an arcuate slot 51 as shown in FIG. 6. A user may push the link 41A to translate along the slot 51 to rotate the door 33A between the open and closed positions, so that the combustion chamber may be cleared of ash when needed, and then closed for further operation.

With reference to FIG. 7, there is shown a more detailed view of the components of the burner assembly 21 of FIGS. 2-5 and are accorded the same reference numerals. In this embodiment the access door 33B is secured to the bottom panel of housing 24 by supports that enable the access door to translate from the open to the closed position. As before, the door 33B is connected to a pull link 41B as shown in FIG. 7 to enable translation of the door 33B along the axis of the link 41B to accomplish opening and closing of the access door as explained in the foregoing.

It should be noted that the description of the use of the access door 33-33B does not mention nor require any task involving disassembly of the upper grill components in the pan section 16, such as the grate(s) 17, flame spreader, or heat deflector. Thus the access door alleviates a great amount of messy, aversive work required to clean ash out of prior art pellet-fired grills.

With regard to FIGS. 2 and 8-10, a further aspect of the invention comprises a stop catch mechanism 51 that is secured to a sidewall 50 of the grill superjacent to the point where the pull link 41 (or 41B) protrudes from the sidewall 50, which may be at the front or side or rear of the assembly. It has been noted that opening the door 33 during operation of the grill may be dangerous, particularly since the combustion chamber contains the positive pressure of the blower as well as hot embers and ash debris at the bottom thereof. If the handle 42 is pulled accidentally, as by a passerby, an inexperienced grill operator, or malicious mischief, directed air supply to the combustion chamber may cause the ash and embers to be blown all over the nearby area and the persons occupying it.

The stop catch mechanism 51 includes a plate 52 extending parallel to the sidewall 50 of pan section 16, and a finger tab 53 extending outwardly and generally orthogonally from the plate 52 at the upper edge thereof. A pair of screw slots 54 extend generally vertically and parallel to opposed ends of the plate 52, and screws 56 extend through the slots 54 and are anchored in the sidewall 50, enabling the mechanism 51 to slide vertically through a limited excursion. Extending outwardly from a central portion of the lower edge of the

5

plate **52** is an arched projection **57** having a central clevis opening **58**. As shown best in FIG. **10**, the clevis opening **58** is a downwardly opening slot having opposed side edges joined by a smoothly curved interior edge.

With particular reference to FIG. **8**, the pull link **41** described previously is modified with the addition of an annular detent recess **43** disposed adjacent to the stem end of pull knob **42**. The detent recess **43** may be defined by a bushing **44** assembled to the pull rod **41** adjacent to the stem end of the knob, or the recess **43** may comprise an annular groove that is milled, turned, molded, printed, or otherwise formed by well known manufacturing processes. The annular detent recess is dimensioned and disposed to be engageable by the clevis opening **58** of stop catch mechanism **51**. As shown in FIG. **9**, the stop catch mechanism is typically disposed in a downward position with the clevis opening **58** engaged with the detent recess **43** in complementary fashion, thus preventing the knob **42** from being pulled outwardly to open the access door **33**. Thus accidental opening of the combustion chamber while in use is prevented.

To open the access door **33** when the grill is turned off and cool, the user must first slide the mechanism **51** upwardly by engaging the finger tab **53**, thus releasing the clevis opening **58** from the detent recess **43**. The user may then easily pull the knob **42** to dump the accumulated ash from the combustion chamber, as described previously. After the ash disposal process, the finger tab **53** may be used to push the mechanism **51** downwardly to re-engage the detent recess **43** and establish the detented position as an ongoing safety precaution.

It is noted that the mechanism **51** may be applied to all the embodiments described above, such as those of FIGS. **6** and **7** without departing from the spirit and teachings of this invention.

The foregoing description of the preferred embodiments of the invention has been presented for purposes of illustration and description. It is not intended to be exhaustive or to limit the invention to the precise form disclosed, and many modifications and variations are possible in light of the above teaching without deviating from the spirit and the scope of the invention. The embodiment described is selected to best explain the principles of the invention and its practical application to thereby enable others skilled in the art to best utilize the invention in various embodiments and with various modifications as suited to the particular purpose contemplated. It is intended that the scope of the invention be defined by the claims appended hereto.

6

The invention claimed is:

1. In a cooking grill that has a grate for supporting food to be cooked and a pellet fuel combustion unit beneath the grate with a combustion housing supporting a combustion chamber where pellet fuel is burned to ash, the improvement comprising:

an access opening formed in a bottom panel of said combustion chamber, said access opening disposed substantially directly beneath said combustion chamber;

an access door dimensioned to entirely close said access opening;

a pull link assembly for translating said access door in a longitudinal direction from a first position in which said access opening is blocked to a second position in which said access opening is open to allow accumulated ash in said combustion chamber to fall therethrough;

said pull link assembly including a pull rod extending from said access door in said longitudinal direction, and a knob secured to a distal end of said pull rod;

said cooking grill including a pair of opposed side walls, a pellet supply bin secured to one of said side walls, and said pull rod protruding from the other one of said pair of sidewalls of said cooking grill;

a stop catch mechanism secured to said other sidewall adjacent to said pull rod and disposed to releasably engage said pull rod;

said stop catch mechanism including plate having a clevis opening adjacent to said pull rod, and an annular detent recess formed on said pull rod and disposed to be engaged by said clevis opening.

2. The improved cooking grill of claim **1**, wherein said plate includes at least one slot extending therethrough to receive a fastener anchored in said other sidewall of said cooking grill, said plate being slidable along said at least one slot.

3. The improved cooking grill of claim **2**, wherein said at least one slot is oriented to enable said plate to slide reciprocally and engage or disengage said annular detent recess with said clevis opening.

4. The improved cooking grill of claim **3**, further including a finger tab extending generally outwardly from said plate to enable manual engagement of said stop catch mechanism.

* * * * *