

(19) **DANMARK**

(10) **DK/EP 3218033 T3**



(12) **Oversættelse af
europæisk patentskrift**

Patent- og
Varemærkestyrelsen

-
- (51) Int.Cl.: **A 61 M 11/00 (2006.01)** **A 61 M 15/00 (2006.01)** **B 05 B 17/06 (2006.01)**
- (45) Oversættelsen bekendtgjort den: **2019-08-05**
- (80) Dato for Den Europæiske Patentmyndigheds bekendtgørelse om meddelelse af patentet: **2019-06-12**
- (86) Europæisk ansøgning nr.: **15791671.9**
- (86) Europæisk indleveringsdag: **2015-11-11**
- (87) Den europæiske ansøgnings publiceringsdag: **2017-09-20**
- (86) International ansøgning nr.: **EP2015076359**
- (87) Internationalt publikationsnr.: **WO2016075209**
- (30) Prioritet: **2014-11-11 GB 201420061**
- (84) Designerede stater: **AL AT BE BG CH CY CZ DE DK EE ES FI FR GB GR HR HU IE IS IT LI LT LU LV MC MK MT NL NO PL PT RO RS SE SI SK SM TR**
- (73) Patenthaver: **The University Court Of The University Of Glasgow, Gilbert Scott Building , University Avenue, Glasgow G12 8QQ, Storbritannien**
- (72) Opfinder: **REBOUD, Julien, Division of Biomedical Engineering, School of Engineering, Rankine Building, Oakfield Avenue, University of Glasgow, Glasgow G12 8LT, Storbritannien**
WILSON, Robert, Division of Biomedical Engineering, School of Engineering, Rankine Building, Oakfield Avenue, University of Glasgow, Glasgow G12 8LT, Storbritannien
COOPER, Jonathan, Division of Biomedical Engineering, School of Engineering, Rankine Building, Oakfield Avenue, University of Glasgow, Glasgow G12 8LT, Storbritannien
- (74) Fuldmægtig i Danmark: **Zacco Denmark A/S, Arne Jacobsens Allé 15, 2300 København S, Danmark**
- (54) Benævnelse: **FORSTØVNING AF VÆSKER**
- (56) Fremdragne publikationer:
WO-A1-2004/085079
WO-A1-2012/096378
WO-A1-2013/166542
CN-A- 102 985 190
US-A- 5 996 903
US-A1- 2011 068 193

DESCRIPTION

BACKGROUND TO THE INVENTION

Field of the invention

[0001] The present invention relates to devices and methods for nebulising liquids and liquid suspensions. The invention has particular, but not necessarily exclusive, applicability to the preparation of therapeutic agents suitable for delivery to subjects.

Related art

[0002] According to the World Health Organization (WHO) there are 235 million people suffering from asthma and 64 million people with chronic obstructive pulmonary disease (COPD), leading to 3 million deaths per year worldwide. Many millions also suffer with pulmonary infectious disease, cystic fibrosis, pulmonary hypertension and allergic rhinitis as well as other under-diagnosed chronic respiratory diseases. Estimates of the cost of treating patients with such lung diseases, including those caused by tuberculosis (TB), COPD, cystic fibrosis, pneumonia, asthma and smoking was Euro 380 billion per annum (according to the European Lung White Book of the European Respiratory Society <http://www.erswhitebook.org/> [accessed 12 August 2014]).

[0003] Generally, patients with such respiratory diseases can be treated by the inhalation of aerosols or by alternate non-lung target routes such as oral and intravenous. One of the major advantages of the inhalation pulmonary route is that it can be targeted directly to the lung, and indeed, effective delivery of medication has been shown to be crucially dependent upon the droplet size distribution within the aerosol of medicine [Brun et al 2000]. In general, if the size is too small ($< 0.5 \mu\text{m}$), the droplet will be exhaled, whilst if the size is too large ($> 5.0 \mu\text{m}$), the droplet will be trapped in the upper respiratory tract or throat. The accepted wisdom is that pulmonary drug delivery requires droplet size distribution of the aerosols with diameters between about 1 and 5 μm . Generating droplets of the optimum size allows medicine to reach and stay in the lungs at the correct therapeutic dose.

[0004] In addition to drug delivery, there are many other therapeutic strategies that would benefit from localised and effective lung delivery through inhalation of aerosols. For example, both gene- and RNA-focused therapies can be targeted directly into the lung, providing an appealing strategy for therapy. However, the efficiency of the approach, coupled with the breadth/limitation of cell type(s) that are required to be targeted for therapeutic efficacy are important considerations. For example, targeting the lung epithelium in cystic fibrosis patients is extremely difficult due to certain anatomical and pathological challenges and, as a

consequence, has limited the clinical data obtained with a range of gene therapy approaches at both the pre-clinical and clinical level. Alternatively, targeting vascular cells is also appealing for treating patients with pulmonary arterial hypertension, although, again, effective delivery to the blood vessels necessitates that the therapeutic system (or droplet) has to transit defined and substantial anatomical barriers.

[0005] Thus, in short, there is a significant potential for improving the delivery of drugs and biologics (including genes and RNA) by preparing substantially monodisperse aerosol droplets that are able to enter the appropriate tissue within the lung. Such a technique would enable new therapies, providing access to a substantial market allowing the reduction of healthcare costs and the improvement of clinical outcomes.

[0006] One device for producing atomised droplets is described in WO 2012/096378, which proposes a surface acoustic wave atomiser comprising a substrate formed from a piezoelectric material. A pair of comb-shaped electrodes for generating a surface acoustic wave and a slit-shaped cut-out that reaches the propagation region for the SAW are formed on the surface of this substrate. A liquid introduced at one end side of the cut-out is supplied to the propagation region for the SAW by the capillary phenomenon and is atomised on the substrate surface along the edges of the opening of the cut-out.

SUMMARY OF THE INVENTION

[0007] The present invention has been devised in order to address at least one of the above problems. Preferably, the present invention reduces, ameliorates, avoids or overcomes at least one of the above problems.

[0008] The present invention is based on the inventors' findings that the controlled actuation of a liquid suspension placed in an array of suitable cavities and excited by surface acoustic waves at suitable frequencies can provide nebulised droplets of the liquid suspension with a tight distribution of droplet size.

[0009] The present invention has arisen from the inventors' work on fluid manipulation using surface acoustic waves, disclosed in WO 2011023949, WO 2011060369, WO 2012114076 and WO 2012156755. WO2012/096378 discloses a SAW atomizer having features as in the preamble of the appended claim 1.

[0010] Nebulisers are used to administer medication or other therapies in the form of a mist inhaled into the lungs. These devices are currently used to deliver various drugs for the treatment of cystic fibrosis, asthma, COPD and other respiratory diseases [Bo et al (2001)]. Nebulizers use oxygen, compressed air or ultrasonic power to break up medical solutions and suspensions into small aerosol droplets that can be directly inhaled from the mouthpiece of the device.

[0011] There are considered to be four main nebuliser systems available at the time of writing [Dolovich and Dhand (2011)] - conventional (using compressed air); ultrasonic (using crystals to vibrate the medication to a mist); vibrating mesh technology (using a vibrating metal mesh to create a mist of droplets from medication) and adaptive aerosols (using vibrating technology mesh combined with optimal breathing monitoring).

[0012] All four classes of current nebuliser systems have limitations in the amount of drug that they can deliver to the lung, which is typically 70%-80% of the dose. For patients this results in sub-optimal treatment regimes with consequent impact on health and wellbeing. A particular disadvantage of the ultrasonic nebuliser is that it is unable to nebulise suspensions and liquid with high viscosity and surface tension [Reboud, Wilson et al (2012); Reboud, Bourquin et al (2012); Qi et al (2008)]. Additionally, the present inventors consider that the droplet size distribution provided by current nebuliser systems is too broad.

[0013] In the preferred embodiments of the present invention, there is provided control over the aerosol droplet size and size distribution. Accordingly, the present invention has the potential to provide patients with better [>95%] delivery of active drug per dose, thereby improving treatment outcomes e.g. infection control in cystic fibrosis or managing asthmatic conditions.

[0014] In a first preferred aspect, the present invention provides a device for the preparation of nebulised droplets, the device having:

a surface acoustic wave (SAW) transmission surface;

a SAW transducer adapted to generate and propagate SAWs along the SAW transmission surface; and

an array of cavities opening at the SAW transmission surface for containing a liquid, the cavities having a depth direction perpendicular to the SAW transmission surface

characterized in that

the cavities have a maximum dimension in a direction perpendicular to the depth of the cavities of at most 500 μm ,

wherein, in operation, SAWs propagating along the SAW transmission surface interact with the liquid in the cavities to produce nebulised droplets of the liquid.

[0015] In a second preferred aspect, the present invention provides a method for the preparation of nebulised droplets, including providing a device according to the first preferred aspect, the method including the steps:

containing a liquid in the cavities; and

causing SAWs to propagate along the SAW transmission surface to interact with the liquid in the cavities to produce nebulised droplets of the liquid.

[0016] Also discussed herein is a method for the preparation of nebulised droplets and their delivery to a subject for therapeutic treatment, including providing a device having a surface acoustic wave (SAW) transmission surface, a SAW transducer adapted to generate and propagate SAWs along the SAW transmission surface, and an array of cavities opening at the SAW transmission surface, the method including the steps:

containing a liquid in the cavities;

causing SAWs to propagate along the SAW transmission surface to interact with the liquid in the cavities to produce nebulised droplets of the liquid; and

delivery of the nebulised droplets to the subject for therapeutic treatment by inhalation.

[0017] Also discussed herein is a medicament in liquid form for use in a method for the preparation of nebulised droplets of the medicament and their delivery to a subject for therapeutic treatment, including providing a device having a surface acoustic wave (SAW) transmission surface, a SAW transducer adapted to generate and propagate SAWs along the SAW transmission surface, and an array of cavities opening at the SAW transmission surface, the method including the steps:

containing the medicament in the cavities;

causing SAWs to propagate along the SAW transmission surface to interact with the medicament in the cavities to produce nebulised droplets of the liquid; and

delivery of the nebulised droplets to the subject for therapeutic treatment by inhalation.

[0018] Preferably, the medicament is for treatment of one or more conditions selected from the group consisting of: asthma; chronic obstructive pulmonary disease (COPD); pulmonary infectious disease; cystic fibrosis; pulmonary hypertension; allergic rhinitis; other chronic respiratory diseases; pneumonia; tuberculosis (TB); lung disease such as lung disease caused by smoking; diabetes; acute or chronic pain; multiple sclerosis; osteoporosis; infectious disease.

[0019] Preferably, the medicament comprises one or more compounds selected from the group consisting of:

Hydrocortisone (C₂₁H₃₀O₅);

Testosterone (C₁₉H₂₈O₂);

Dexamethasone (C₂₂H₂₉FO₅);

Budesonide (C₂₅H₃₄O₆);

Betamethasone (C₂₂H₂₉FO₅);

Cromolyn (C₂₃H₁₆O₁₁);

Formoterol (C₁₉H₂₄N₂O₄);

Imipramine (C₁₉H₂₄N₅);

Losartan (C₂₂H₂₃ClN₆O);

Terbutaline (C₁₂H₁₉NO₃);

Salbutamol (C₁₃H₂₁NO₃);

Zopiclone (C₁₇H₁₇ClN₆O₃);

Zaleplon (C₁₇H₁₅N₅O);

Zolpidem (C₁₉H₂₁N₃O);

Leflunomide (C₁₂H₉F₃N₂O₂);

Oxymetazoline (C₁₆H₂₄N₂O);

Insulin;

Morphine;

Interferon Beta 1a;

Parathyroid hormone;

Nicotine;

One or more antibiotics;

and pharmaceutically acceptable derivatives and salts thereof, optionally including excipients and carriers such as nanoparticles.

[0020] A review of candidate pharmaceutical compositions for pulmonary delivery is set out in Eixarch et al (2010), the entire content of which is hereby incorporated by reference.

[0021] The above aspects of the invention may be combined with each other in any combination. Furthermore the above aspects of the invention may have any one or, to the

extent that they are compatible, any combination of the following optional features.

[0022] The liquid may be one or more of: a pure compound; a mixture of liquids; a solution of one or more solutes in a liquid solvent; a suspension of particles (solid, substantially solid or liquid) in a carrier liquid; a colloid; an emulsion; nanoparticles or a suspension of nanoparticles.

[0023] The SAW transmission surface may be a surface of the SAW transducer. However, more preferably, the SAW transmission surface is a surface of a superstrate coupled to the SAW transducer.

[0024] The present invention is not necessarily limited to any particular orientation. The term "superstrate" is used because in typical implementations of embodiments of the invention, this item is placed on top of the SAW transducer. However, other orientations are contemplated, e.g. in which a corresponding substrate is placed under the transducer, yet the same effect of the invention can be seen, in which the sample is nebulized from cavities in the surface of the substrate. Furthermore, the present invention is not necessarily limited to a planar configuration. For example, the transducer may be formed inside the superstrate, e.g. in a tubular configuration. Alternatively, the transducer may be formed around the superstrate, with the superstrate in the form of a tube (or hollow needle) held inside a transducer tube. This may be preferred, in order that a continuous (or quasi continuous) supply of sample fluid may be provided to the superstrate tube, with the nebulized plume provided at a free end of the superstrate tube. Preferably, the superstrate is formed of a material which is impervious to the liquid. This helps to avoid any (potentially contaminating) contact between the transducer and the liquid.

[0025] Preferably, the transducer comprises a layer of piezoelectric material. For example, the layer of piezoelectric material may be a sheet (e.g. a self-supporting sheet) of piezoelectric material. The layer of piezoelectric material may be a single crystal, such as a single crystal wafer. A suitable material is LiNbO_3 . A preferred orientation for the cut for this material is Y-cut rot. 128° . This has a higher electromechanical coupling coefficient than other orientations. Other ferroelectric materials may be used, e.g. PZT, BaTiO_3 , SbTiO_3 or ZnO. Still further, materials such as SiO_2 (quartz), AlN, LiTaO_3 , Al_2O_3 , GaAs, SiC or polyvinylidene fluoride (PVDF) may be used. As an alternative to a single crystal, the material can be provided in polycrystalline or even amorphous form, e.g. in the form of a layer, plate or film.

[0026] The transducer preferably further comprises at least one arrangement of electrodes. For example, the electrodes may be interdigitated. More preferably, the transducer comprises two or more arrangements of electrodes. In some embodiments, it is preferred that the transducer is tunable, such that the lateral position of the SAWs emission train is movable. For example, the slanted interdigitated arrangement of electrodes suggested by Wu and Chang (2005) can be used for the transducer.

[0027] The superstrate may be permanently coupled to the piezoelectric layer, in the sense that it is not removable from the piezoelectric layer without damage to the device.

[0028] Alternatively, coupling between the transducer and the superstrate may be achieved using a coupling medium, preferably a fluid or gel coupling medium. The coupling medium may be an aqueous coupling medium, e.g. water. Alternatively, the coupling medium may be an organic coupling medium, such as an oil-based coupling medium or glycerol. The coupling medium provides intimate contact between the superstrate and the transducer and allows the efficient transfer of acoustic energy to the superstrate from the transducer.

[0029] The advantage of providing the superstrate as a separate entity from the transducer is very significant. Typical SAW transducers are complex to manufacture. For this reason, they are typically expensive. Contamination of the transducer may be difficult or impossible to remove, if the liquid is allowed to come into contact with the transducer. Alternatively, removal may not be cost-effective, or may damage the transducer. However, it is strongly preferred that the transducer can be re-used. Accordingly, it is preferred that the liquid does not contact the transducer but instead contacts the superstrate coupled to the transducer. The superstrate itself may be disposable (e.g. disposed of after a single use). The superstrate may be formed by various methods, such as microfabrication, embossing, moulding, spraying, lithographic techniques (e.g. photolithography), etc.

[0030] The cavities preferably have substantially the same shape. The SAW transmission surface, in use, preferably is held substantially horizontal. In this way, the cavities preferably open in the upward direction. The cavities may be closed at an end distal from the SAW transmission surface. Alternatively, the cavities may be open at an end distal from the SAW transmission surface.

[0031] The cavities may be substantially columnar in shape. In this way, the cross sectional shape of the cavities may be substantially uniform with depth (a direction perpendicular to the SAW transmission surface). For example, the cross sectional shape of the cavities in the depth direction may be rectangular, square, rounded, oval, elliptical, circular, triangular. Most preferably the cross sectional shape of the cavities in the depth direction is circular. The cross sectional area of the cavities may be uniform with depth. However, in some embodiments this may not be the case, allowing the cavities to have a cross sectional area which narrows, expands or undulates with depth. For example, funnel-shaped cavities may be provided (such cavities being capable of being formed using a KOH etch for example), to provide suitable volume in the cavity to retain the liquid.

[0032] The cavities may have an internal structure. For example, there may be provided one or more pillars upstanding in the cavities, walls projecting into the cavities or other projections into the cavities. The internal walls of the cavities may have one or more array of such projections. The array of projections may be considered to be a phononic structure, in the sense that it is based on a periodic arrangement (in the manner disclosed in WO 2011023949, WO 2011060369, WO 2012114076 and WO 2012156755) for affecting the distribution and/or transmission of SAWs in the cavities. In the case of one or more pillars, there may be provided one or more support struts extending to the pillar to hold it in position. This is particularly the

case if the cavity has two open ends (i.e. extends through the superstrate) since in this case there is no base of the cavity for the pillar to be supported on.

[0033] Such internal structure interact with the liquid and with the SAWs in a manner which can further improve the performance of the cavities in restricting the droplet size distribution.

[0034] The cavities preferably have substantially the same dimensions.

[0035] Preferably the depth of the cavities is at least $1\mu\text{m}$. Preferably the depth of the cavities is at most 1mm , more preferably at most $500\mu\text{m}$. In some embodiments, the cavities can be blind cavities. However, in other embodiments the cavities can open at a surface opposite to the SAW transmission surface. This is preferred, for example, where the liquid to be nebulised is fed to the cavity from one or more reservoirs.

[0036] Preferably the maximum dimension of the cavities in a direction perpendicular to the depth of the cavities is at least $1\mu\text{m}$. This lower limit is set in view of the preferred lower limit for droplet size. The lower limit may be at least $2\mu\text{m}$, at least $5\mu\text{m}$, at least $10\mu\text{m}$, at least $20\mu\text{m}$, at least $30\mu\text{m}$, at least $40\mu\text{m}$ or at least $50\mu\text{m}$. This maximum dimension is at most $500\mu\text{m}$, more preferably at most $400\mu\text{m}$, at most $300\mu\text{m}$ or at most $200\mu\text{m}$. Where the cavities have a circular cross section shape, this dimension is referred to as the diameter of the cavities. Where the cavities have a non-circular cross sectional shape, this maximum dimension is also referred to as the diameter.

[0037] The present inventors have considered the effect of this dimension on the efficacy of the invention. Capillary waves, in the context of the present invention, can be considered to be waves which are capable of travelling along the free surface of the liquid, whose dynamics are dominated by surface tension effects. In common terminology, they can be considered to be "ripples" in the manner of ripples on the surface of a body of water. Capillary waves in a body of liquid constrained in a cavity can be produced at a fundamental vibrational mode, and/or at harmonic vibrational modes. Without wishing to be bound by theory, it is considered to be of importance to restrict the ability of the volume of liquid contained in the cavity to support capillary waves at the fundamental mode and preferably also at harmonic modes (particularly lower harmonic modes). This is because it is considered that such capillary waves would otherwise be responsible for the formation of relatively large droplets.

[0038] Therefore it is preferred that the diameter of the cavities is suitable to reduce or prevent the formation of such capillary waves in the liquid contained in the cavities. Put simply, at least for relatively low operational frequencies (in the kHz range, for example, i.e. less than 1MHz), the diameter D of the cavities is preferably less than the wavelength of capillary waves which could otherwise be formed in the liquid at the driving frequency f .

[0039] The driving frequency f can be considered to be responsible for the generation of capillary waves at a fundamental mode of vibration and/or at one or more harmonic modes of vibration. The order of the mode of capillary vibration can be denoted m . The frequency of a

particular mode of capillary vibration can be denoted f_m .

[0040] The driving frequency f may be identical to f_m , but in many cases f is only loosely correlated with f_m . Therefore f_m can vary with respect to f , typically within a range such as:

$$(f_m)^l \leq f \leq (f_m)^h$$

l is the exponent for the lower limit, and l is 0.5, more preferably 0.6, 0.7, 0.8, 0.9 or 1.0. h is the exponent for the upper limit, and h is 1.5, more preferably 1.4, 1.3, 1.2, 1.1 or 1.0.

[0041] Preferably, at least the fundamental capillary vibration mode is suppressed. Therefore preferably $m = 0$ at least. However, additionally or alternatively low order harmonic capillary vibration modes may be suppressed. Therefore in some embodiments, one or more of $m = 1$, $m = 2$, $m = 3$, $m = 4$, $m = 5$, $m = 6$, $m = 7$, $m = 8$, $m = 9$, $m = 10$ and optionally higher, applies.

[0042] The progression of resonant responses from the fundamental mode upward are provided by the Lamb model, as set out in Blamey et al (2013), which applies in particular to the elastic resonance of a spherical capillary surface but applies within a reasonable approximation in preferred embodiments of the present invention in which the liquid is held in cavities:

$$f_m = \sqrt{\frac{(m+1)(m+2)(m+4)\gamma}{3\pi\rho L^3}}$$

where L , f_m and m are as defined above, γ is the surface tension of the liquid in the cavity and ρ is the density of the liquid.

[0043] Blamey et al (2013) provides a list of modes, with specific frequencies (f_m) and lengths (L_m). These are eigenvalues and L_m represent the size of the deformation at the interface. The cavities (diameter D) should preferably be smaller than L_m .

[0044] The present inventors consider that the effect of locating the liquid in the cavities is that, under a particular SAW excitation frequency f , the liquid is pinned by the cavities, suppressing or forbidding capillary waves which would otherwise form under those conditions, thereby suppressing the generation of large droplets by such capillary waves.

[0045] It is considered to be important that liquid emanating from a cavity does not come into contact with neighbouring cavities or liquid from neighbouring cavities. This is because such contact would increase the free surface area of the liquid and as such increase the degrees of freedom and enable larger wavelength capillary waves to form. As such, depth of the cavity or its shape or the surface chemistry close to the nebulising surface can be important to ensure efficient pinning of the contact line. Suitable depth of the cavities can be between 500 and 50 μ m. The deeper the cavity (for a particular cross section shape and diameter) the more liquid that can be nebulised in one 'charge'. Through hole-type cavities have been used having a depth of 380 μ m, but such a depth is determined by the thickness of the substrate (or superstrate) in which the cavity is formed, rather than a functional limitation.

[0046] As mentioned above, preferably the cavities have substantially the same dimensions. However, it is allowable for the cavities to have a distribution of dimensions. In terms of the diameter of the cavities, preferably the standard deviation of the diameter is 40% or less, more preferably 30% or less, more preferably 20% or less.

[0047] The cavities can be in the form of cylindrical holes. As indicated above, in some embodiments the holes can be blind holes. In other embodiments, the holes can be holes which open also at an opposing surface to the SAW transmission surface, in order that additional liquid can be fed into the cavities by capillarity. A suitable volume for the cavities in either can be at least 0.5nl, more preferably at least 1nl. This volume is preferably at most 50nl, more preferably at most 20nl, more preferably at most 10nl, more preferably at most 5nl. As an example, a cylindrical hole of diameter 100 μ m and depth 300 μ m has a volume of about 2nl.

[0048] The array of cavities may not have long range order. In this case, the arrangement of the cavities may be substantially random, in the sense of not being based on a periodic arrangement.

[0049] It is preferred that the cavities have an average cavity-to-cavity nearest neighbour spacing (measured from the central axis of each cavity) of at least 10 μ m. This is suitable for SAWs in the MHz region (e.g. of frequency of around 100 MHz). More preferably, this spacing is at least 20 μ m, at least 40 μ m, at least 60 μ m, at least 80 μ m, or at least 100 μ m. This spacing may be at most 5 mm (corresponding to relatively low frequency SAWs), more preferably at most 4 mm, more preferably at most 3 mm, more preferably at most 2 mm, more preferably at most 1 mm, more preferably at most 0.9 mm, at most 0.8 mm, at most 0.7 mm, or at most 0.6 mm. For example, a cavity-to-cavity nearest neighbour spacing in the range 200-500 μ m has been shown to be suitable. For higher frequencies, e.g. in the GHz range, smaller spacings are contemplated, e.g. in the range down to at least 1 μ m. Spacing between the cavities is considered to be important in order to prevent liquid merging as it escapes from adjacent cavities.

[0050] The frequency of the surface acoustic wave may be in the range of about 10kHz to about 1 GHz, preferably about 1MHz to about 100MHz, more preferably about 5MHz to about 50MHz, more preferably about 5MHz to about 20MHz, more preferably about 15 MHz to about 5 MHz, more preferably between about 13 MHz and about 8 MHz. The frequency of the surface acoustic wave may be about 12 MHz, about 11 MHz, about 10 MHz, about 9 MHz or about 8 MHz.

[0051] The SAW transducer may be formed from any suitable material for generating surface acoustic waves. SAWs may be generated, for example, by a piezoelectric process, by a magnetostrictive process, by an electrostrictive process, by a ferroelectric process, by a pyroelectric process, by a heating process (e.g. using pulsed laser heating) or by an electromagnetic process. It is most preferred that the SAW generation material layer is formed from a piezoelectric layer. In the disclosure set out below, the term "piezoelectric layer" is used

but is it understood here that similar considerations would apply to SAW generation material layers formed, for example, of magnetostrictive materials. Therefore, unless the context demands otherwise, the optional features set out in relation to the "piezoelectric layer" are to be understood as applying more generally to the SAW generation material layer, when formed of any suitable material.

[0052] The present inventors further consider that the present invention is not necessarily limited to the use of SAWs. It is considered that nebulisation using other acoustic waves, such as bulk acoustic waves, is possible using the principles of the present invention. Such acoustic waves are susceptible of manipulation in a similar manner to SAWs. Bulk acoustic waves, for example, give rise to corresponding acoustic waves or displacements at a free surface. Therefore, in the present disclosure, it is to be understood that SAWs are only one example of a suitable acoustic wave which can be used to provide suitable manipulation of a sample. Thus, although in this disclosure the terms "SAW", "surface acoustic wave", "SAWs" and "surface acoustic waves" are used, it is to be understood that these may be substituted or supplemented by the terms "bulk acoustic wave" and "bulk acoustic waves" or the terms "acoustic wave" and "acoustic waves", unless the context demands otherwise.

[0053] Preferably, in use, when the SAW transmission surface is facing upwards, the liquid is contained in the cavities such that the free surface of the liquid is below the level of the SAW transmission surface. Thus, it is preferred that the free surface of the liquid is not located at or above the level of the SAW transmission surface. This allows the liquid contained in the cavities to be isolated from each other, forbidding the formation of capillary waves at the liquid contained in the cavities.

[0054] The interior surface of the cavities may be treated in order to promote the containment of the liquid in the cavities. For aqueous liquids, preferably the interior surface of the cavities is formed to be hydrophilic. For non-aqueous liquids, preferably the interior surface of the cavities is formed to be hydrophobic.

[0055] Additionally or alternatively, the SAW transmission surface may be treated in order to promote the containment of the liquid in the cavities. For example, this treatment may be selectively carried out at the array of cavities intended to contain the liquid. For aqueous liquids, preferably the SAW transmission surface is formed to be hydrophilic. For non-aqueous liquids, preferably the SAW transmission surface is formed to be hydrophobic. Preferably, an area of the SAW transmission surface at which it is not intended for the liquid to be located is formed to be hydrophobic or hydrophilic, respectively, to promote the location of the liquid at the array of cavities intended to contain the liquid.

[0056] Preferably, operation of the device results in a nebulised plume of droplets of average diameter in the range 1-5 μ m. Preferably, the droplet diameter is measured by laser diffraction. Such measurements provide a droplet size distribution curve in the form of a number-based distribution (i.e. number of droplets is shown on the ordinate and diameter of droplets is shown on the abscissa).

[0057] The respirable fraction of the droplets can be defined as the integral of the droplet size distribution in the diameter range 1-5 μ m (N_{1-5}) divided by the integral of the droplet size distribution over the total diameter range measured (N_{total}). Thus, respirable fraction can be defined as $(N_{1-5})/(N_{total})$.

[0058] Preferably, operation of the device results in a nebulised plume of droplets with a respirable fraction of at least 80%, preferably at least 85%, more preferably at least 90%, more preferably about 95% or higher.

[0059] In the prior art, it is known to filter out larger droplets from a nebulised plume in order to restrict the droplet size distribution which reaches the subject. However, this reduces the efficiency of the device, by reducing the proportion of the dose which reaches the subject, and clogging is also a problem, wherein captured large droplets prevent subsequent smaller droplets from being passed through. In the present invention, it is preferred that the respirable fraction is determined on the basis of the nebulised plume formed from the cavities, and not subjected to filtration prior to determination of the droplet size distribution.

[0060] In preferred embodiments, the present invention may provide supply of liquid for nebulisation. Since the cavities are relatively small, it may be preferred to ensure a supply of additional liquid for nebulisation. This supply may be continuous, in the sense that liquid is supplied to the cavities for nebulisation while nebulisation is being carried out. Alternatively, this supply may be intermittent, in the sense that liquid is supplied to the cavities after some liquid has been nebulised from the cavities and before nebulisation of the additional liquid is begun. This alternative approach can be considered to be a repeating nebulisation approach.

[0061] Preferably, the device is capable of nebulising the liquid at a rate of at least 5ml/min.

[0062] The liquid may have relatively high viscosity, because the mechanism of the nebulisation provided in the present invention can tolerate relatively high viscosity. The viscosity of the liquid (measured at room temperature) may be at least 0.5 mPa.s, but in some embodiments may be at least 1 mPa.s, at least 5 mPa.s, or at least 10 mPa.s. For reference, at room temperature ethanol has viscosity of 1.07mPa.s, bovine serum albumin 5% in phosphate buffer has viscosity of 1.5mPa.s, glycerol has viscosity of 1200mPa.s and water has viscosity of 0.894mPa.s.

[0063] The surface tension of the liquid (measured at room temperature) may be at least 10 mN/m. In some embodiments, the surface tension may be at least 50 mN/m. For reference, at room temperature ethanol has a surface tension of 22.1mN/m, bovine serum albumin 5% in phosphate buffer has a surface tension of 55.0 mN/m, glycerol has a surface tension of 63.0mN/m and water has a surface tension of 71.9mN/m.

[0064] The supply of liquid may be provided, for example, by a syringe pump. Other metered liquid supply systems may be used.

[0065] In order to supply additional liquid to the cavities, it is possible for the cavities to be open at their end distal from the SAW transmission surface. In that case, the distal ends of the cavities may be in fluid communication with a reservoir of the liquid, to be drawn up by capillarity into the cavities to replace liquid lost by nebulisation. In this case, it is possible for the liquid to be used as the coupling agent for the superstrate.

[0066] In order to provide adequate rate of nebulisation, the device may include a plurality of arrays of cavities, in order that there is a suitable number of cavities operating to contribute to the rate of nebulisation (in terms of the volume of liquid nebulised in total by the device per unit time). These may each be associated with a corresponding respective SAW transducer. However, it is possible for the plurality of arrays of cavities to be operated using a single SAW transducer. In order to provide a suitable distribution of SAWs to the respective arrays of cavities, the device may include phononic arrays, as set out in WO 2011023949, WO 2011060369, WO 2012114076 and/or WO 2012156755, in order to concentrate the SAW distribution as required at the respective arrays of cavities.

[0067] Further optional features of the invention are set out below.

BRIEF DESCRIPTION OF THE DRAWINGS

[0068] Embodiments of the invention will now be described by way of example with reference to the accompanying drawings in which:

Fig. 1A shows a schematic plan view of a device according to an embodiment of the invention, in the form of an etched array of cavities in a superstrate on an interdigitated electrode transducer (IDT) surface.

Fig. 1B shows a cross sectional view of the device of Fig. 1A.

Fig. 2 shows the results of droplet size distribution (number-based) analysis of droplets generated from nebulisation (a) an embodiment of the present invention, with the liquid contained in cavities in a silicon superstrate coupled on a SAW device with excitation frequency of 8.6 MHz and input power of 1.5 W (b) Medix nebuliser (c) Medisana nebuliser and (d) directly on the SAW device of (a) with excitation frequency of 8.6 MHz and input power of 1.5 W.

Fig. 3 shows the respirable fraction of nebulised droplet generated from the commercialised nebulisers (Medix (3) and Medisana (4)), directly on SAW devices (2) on silicon superstrate coupled on the SAW device (1) with excitation frequency of 8.6 MHz and input power of 1.5 W

Fig. 4A shows a micrographic image captured from a video of nebulisation at 11.762 MHz and -4dBm of DI water at 2 μ l/min on a plain surface. Large individual drops are seen due to free capillary microjets at the surface of the drop.

Fig. 4B shows a micrographic image captured from a video of nebulisation at 11.762 MHz and -4dBm of DI water at 2 μ l/min located in cavities arranged as a phononic lattice (900 μ m diameter). No large individual drops are seen. As a guide to the scale of the images of Figs. 4A and 4B, the syringe shown in the image is a 1ml syringe, with a syringe body diameter of 5mm.

Fig. 5 shows a schematic cross sectional view of a single cavity.

Fig. 6 shows a schematic cross sectional view of a single cavity which is a modification of the cavity shown in Fig. 5.

Fig. 7 shows a schematic cross sectional view of a single cavity which is another modification of the cavity shown in Fig. 5.

Fig. 8 shows a plan view of the cavity of Fig. 7.

Fig. 9 shows a schematic cross sectional view of a single cavity which is a modification of the cavity shown in Fig. 8.

Fig. 10 shows a plan view of the cavity of Fig. 9.

Fig. 11 shows a graph of droplet size with cavity (pore) diameter, based on an assessment of largest droplet size viewed in video footage.

Figs. 12-14 show images from high frame rate video footage taken using a microscope when water is nebulised from cavities of diameter 80 μ m (Fig. 12), 600 μ m (Fig. 13 - not according to the invention) and 1500 μ m (Fig. 14 - not according to the invention).

DETAILED DESCRIPTION OF THE PREFERRED EMBODIMENTS, AND FURTHER OPTIONAL FEATURES OF THE INVENTION

[0069] Before discussing the features of the preferred embodiments of the present invention in detail, it is useful to consider the features and performance of known ultrasonic nebulisers.

[0070] Ultrasonic nebulisers use the basic principle of applying a high frequency mechanical vibration to a surface. This leads to the excitation of deformations on the free liquid surface that result in microjets [Topp (1973)]. These nebulisers enable the atomisation of a wider range of liquids than other types of nebulisers (such as jet or compressed air). However the aerosol produced suffers from wide range of droplet size. Recently this principle has been extended to the use of SAWs [Reboud, Wilson et al (2012); Qi et al (2009)], which offer the advantages of lower powers and more versatility in integration of preparation functions. However these suffer from similar limitations in the control of the drop size, which generally leads to large mean diameters (above 10 μ m) and multiple modes.

[0071] To provide a tight droplet size distribution, meshes have been introduced as passive

filters (MicroAir™ - OMRON, and microflow - Pfeiffer) situated after the nebulisation process, to select the drops of the correct size. These systems require careful maintenance (to prevent clogging) and show limited efficiency.

[0072] Vibrating meshes combine both approaches at the site of nebulisation [Maehara et al (1986)]. A mesh of apertures is vibrated at ultrasonic frequencies to generate the aerosol from a pinching off of the drops through the aperture, in a similar mechanism as the microjets mentioned previously for SAW nebulisation. A similar system is commercialised for droplet dispensing (Scienion AG).

[0073] In the preferred embodiments of the present invention, the array of cavities is used to prevent the pinching off enabled by the vibrating meshes and thus provide the opportunity of a reduced size without requiring fine apertures (on the order of the size of the drop dispensed). This provides a cheaper manufacturing strategy. It is also not reliant on the surface properties of the mesh and thus can tolerate conditions that would lead to significant clogging, enabling the dispensing on difficult suspensions, such as those with high viscosity.

[0074] Qi et al [2009] have shown nebulisation off a paper superstrate, using SAW. Although the paper superstrate could be viewed as a mesh, their work clearly show no capillary wave limiting effect on the selection of droplet sizes (see Figure 6 of Qi et al [2009], clearly showing large (i.e. greater than 10µm) droplets). This is due to the wide distribution of pore sizes compared to the embodiments presented here. Indeed, in their work, the paper superstrate is used as a matrix to feed the liquid, while the nebulisation happens in a bulk mode (as a drop - see Figure 2c of Qi et al [2009]).

[0075] A preferred embodiment of the present invention is illustrated schematically in Figs. 1A and 1B. This is based on the inventors' previous SAW-based systems [see WO 2011023949, WO 2011060369, WO 2012114076, WO 2012156755, Reboud, Wilson et al (2012) and Reboud, Bourquin et al (2012)].

[0076] The device includes a LiNbO₃ actuator 10 (single crystal, self-supporting) with an interdigitated electrode 12 and a Si superstrate 14, with etched blind holes 16. The holes (i.e. cavities) are arranged in a square periodic lattice array. A liquid (the sample) 18 is positioned inside the cavities. Thus, the height of the liquid in the cavities is less than the depth of the cavities. This is ensured using highly hydrophilic wetting and a small sample volume.

[0077] Upon actuation, the SAW propagates on the SAW transmission surface (the upper surface of the actuator 10) and is coupled onto the superstrate 14, via a coupling medium (not shown) such as gel or water or glue or a more permanent fixture (the array of cavities can be deposited on or etched into the piezoelectric layer). The material of the superstrate 14 is preferably acoustically non-dampening (e.g. Si or glass).

[0078] The superstrate 14 holding the array of cavities can be fully in contact with the piezoelectric actuator 10 (as shown in Figs. 1A and 1B) or coupled only using a small overlap.

[0079] The SAW then interacts with the liquid contained in the cavities 16. This interaction creates a nebulised plume. Here the cavities are used to prevent the creation of microjets of sizes greater than about 10 μm that result in multimodal droplet distribution. The specific mechanism for this is still under investigation by the inventors. Without wishing to be limited by theory, the present inventors believe that the mechanism is linked to the damping, suppression or forbidding of capillary waves propagating at the free surface of the liquid in the cavities. This capillary mechanism has been reported as the primary mechanism for nebulisation using SAW [Qi et al (2008)], and leads to sizes outside the range of interest for drug delivery.

[0080] In more detail, the SAW actuator 10 and the superstrate 14 are manufactured as follows. Positive photoresist, S1818 (Shibley) was used to lithographically define the electrode pattern on the 127.8° Y-cut LiNbO₃ substrate. After the resist exposure and development, 10nm of titanium and 100nm of gold were deposited and lift-off was performed in acetone.

[0081] The superstrate was fabricated using <100> silicon wafer and standard optical photolithography. The array of cavities was constructed using dry etch (STS ICP), down to half the wafer thickness (about 250 μm). Control experiments were carried out on unpatterned superstrates as well as on the LiNbO₃ actuator.

[0082] In order to control the volumes and shape of drops deposited on the surface as well as to create controlled spatial areas for nebulisation, the superstrate was patterned with a hydrophobic silane using standard optical lithography. The process involved developing the exposed S1818 photoresist (Shibley) and surface treatment in O₂ plasma before silanisation in a solution of trichloro (1H, 1H, 2H, 2H perfluorooctyl) silane (Aldrich) in heptane (Aldrich). The superstrate was then rinsed in acetone to create hydrophilic (untreated) spots of varying sizes in the range of 1-15 mm on a hydrophobic surface.

[0083] The frequency response of the SAW actuator was observed using a network analyser (E5071C ENA Series, Agilent Technologies). To perform nebulisation of the liquids on the substrate, a high frequency electrical signal was supplied to the electrodes using a MXG Analog Signal Generator (N5181A, Agilent Technologies) and amplifier (ZHL-5W-1, MiniCircuits).

[0084] The silicon superstrate and the piezoelectric substrate were assembled with KY-jelly (Johnson & Johnson) between them to provide efficient coupling.

[0085] Measurements of droplet size were performed at 8.64 MHz at the input power of 1.5 W. A sessile drop of 3 μL of deionised (DI) water was used for each nebulisation using the embodiment device of the invention. As comparisons, the nebulised droplet size by two commercialised nebulisers, Medix and Medisana were also measured. The Microneb Medix uses a titanium vibrator which oscillates at approximately 180 kHz with input power of 1.5 W to generate the droplet which is then passing through metal alloy mesh. The Medisana is an ultrasonic nebuliser that operates at 100 kHz with input power of 3 W.

[0086] The distributions of nebulised droplet with different sizes were measured using a laser diffraction technique (Spraytec, Malvern Instruments Ltd, UK) and represented in the form of a frequency distribution curve.

[0087] The diameters of the nebulised droplet has been reported by Kurosawa et al (1995) by using a number distribution. They obtained the linear mean diameter, D_{10} and surface mean diameter, D_{32} of 19.2 μm and 34.3 μm , respectively for tap water nebulised directly on a SAW device with excitation frequency of 9.5 MHz and input power of 2.5 W for 0.1 ml/min nebulisation rate. The droplet size distribution had two modes with peaks at 10 μm and 40 μm which were reported to be due to the capillary wavelength and the intermittent burst drive, respectively. Smaller droplets ($D_{10} = 6.8 \mu\text{m}$ and $D_{32} = 15.0 \mu\text{m}$) were obtained using SAW device with higher excitation frequency of 48 MHz and lower input power of 2.3 W for 170 $\mu\text{l}/\text{min}$ nebulisation rate [Kurosawa et al (1997)]. Alvarez et al (2007) successfully nebulised insulin with mean diameter of 4.5 μm using 19.3 MHz SAW device at 0.3 W input power. By using the same image processing technique as previous authors, Ju et al (2008) estimated the mean diameters of nebulised bovine serum albumin (BSA) to be 5.7, 4.4 and 2.7 μm using SAW devices with excitation frequencies of 50, 75 and 95 MHz, respectively. Smaller droplets with mean diameters of 0.36, 0.38 and 0.4 μm were obtained using 10 MHz SAW device with input power of 0.97, 1.00 and 1.03 W, respectively [Ju et al (2010)].

[0088] Fig. 2 shows the distribution obtained for the different surfaces used. They are presented as frequency distributions. The results show that both commercial nebulisers, utilising an ultrasonic technology, provide drop sizes above the optimum size for lung penetration (modes above 5 μm). These distribution are also broad, leading to significant wastage of the targeted therapy.

[0089] As shown in Fig. 2, SAW nebulisation from a plain surface is able to provide a smaller droplet size than the commercial nebulisers, which would fit the therapeutically-relevant range (between 1 and 5 μm). However this actuation leads to secondary peaks (large sizes above 10 μm), and a broad distribution. These features lead to inefficient nebulisation and wastage of the liquid.

[0090] Using the array of cavities to contain the liquid for nebulisation enables the prevention of large secondary peaks, and sharpens the distribution of the peak (1-5 μm) of interest. The results can be presented using the concept of respirable fraction, which reports the proportion of the total size distribution that is enabled by the different systems (the ratio of integral below the curves between 1 and 5 μm , over the total integral), as shown in Fig. 3, while the data analysed is presented in Table 1.

Table 1

Derived parameters of the nebulised droplets generated by the surface acoustic waves devices and commercialised nebulisers measured using the Malvern Spraytec				
	SAW + Si superstrate with cavities	SAW (transducer only)	Medix Microneb	Medisana
Linear mean diameter, D_{v10} (μm)	1.81 ± 0.13	1.32 ± 0.18	3.00 ± 0.27	5.73 ± 0.94
Linear mean diameter, D_{v50} (μm)	2.10 ± 0.16	5.21 ± 6.87	5.84 ± 0.49	13.19 ± 1.89
Linear mean diameter, D_{v90} (μm)	2.50 ± 0.30	52.28 ± 4.06	11.09 ± 1.06	27.13 ± 6.64
Surface mean diameter, D_{32} (μm)	2.16 ± 0.17	3.38 ± 0.82	5.13 ± 0.64	10.04 ± 1.71
Volume mean diameter, D_{43} (μm)	3.45 ± 2.24	17.88 ± 3.47	6.54 ± 0.57	15.06 ± 2.93
% Respirable Fraction ($1 \mu\text{m} < D < 5 \mu\text{m}$)	96.16 ± 4.93	36.44 ± 6.25	38.38 ± 6.14	6.92 ± 2.89

[0091] In order to increase the quantity nebulised and establish the steady-state properties of the system, a syringe pump (NE-1000 Multi-Phaser™, New Era Pump Systems Inc.) was employed to regulate the amount of liquid supplied to the superstrate continuously. The pump was set to a constant flow rate of $1.0 \mu\text{l}/\text{min}$ to maintain continuous production or rapid generation of nebulised droplets.

[0092] Figs. 4A and 4B show example frames extracted from movies on a plain superstrate (Fig. 4A) and on a superstrate having an array of cavities (Fig. 4B), illustrating the proposed hypothesis that the array of cavities prevents the generation of larger droplets.

[0093] The cavities can be formed to extend through the superstrate. This allows the cavities to be replenished with additional liquid by filling from below under capillarity. This allows the delivery of the liquid to be more robust. In this embodiment the liquid can also be used as the coupling agent.

[0094] Using a single spot and powers below 1W, the illustrated embodiment enables flow rates around $20 \mu\text{l}/\text{min}$. The flow rate can be increased significantly by increasing actuation power (up to 5-10W) for a short period of time (<5s).

[0095] In order to further increase the flow rate, there may be provided a plurality of locations (each having an array of cavities) at which nebulisation is carried out substantially simultaneously. In this way, the flow rate can be increased to 5ml/min, or higher.

[0096] It is preferable to establish the nebulisation in specific areas, defined by wetting barriers. However, in the case of isotropic excitation on large arrays of cavities, the liquid may then be assembled in patches by irregularities and build up in volumes that are locally bulging above the surface of the SAW transmission surface of the superstrate. This behaviour would prevent the activity of the cavities and would result in multimodal droplet sizes, due to microdroplet ejection. Thus, it is instead preferred to provide wetting channels at the interface between the superstrate and the piezoelectric actuator. Such channels can also serve as acoustic waveguides to channel the SAWs to the nebulisation areas.

[0097] In preferred embodiments, a suitable cavity diameter is 50-200 μ m. The effect of the diameter on the ability of liquid in the cavities to support capillary waves can be considered based on the driving frequency f . As explained above, the diameter D of the cavities is preferably lower than a size that would allow the generation of unwanted large droplets, thought to be the result of unwanted capillary waves.

[0098] The theoretical framework for the mechanism of large droplet suppression is not fully understood at the time of writing. The application of the progression of resonant responses from the fundamental mode upward, provided by the Lamb model, as set out in Blamey et al (2013), can be considered in which, for the sake of simplicity, the driving frequency f can be considered to be identical to f_m for the fundamental mode. Whilst this is effective for low frequencies (in the kHz range or below) it is not effective for MHz range driving frequencies, for reasons which are not fully understood at the time of writing.

[0099] It is therefore more suitable here to take an empirical approach to the design of the cavities. Fig. 2(d) shows that nebulisation on a flat surface gives rise to a bimodal distribution. However, for the intended use of the nebulised droplets, the second peak (larger drops) is not wanted. In a preferred embodiment of the invention, cavities are formed (cylindrical holes in a superstrate to be coupled to the SAW transducer) having dimensions that prevent the capillary wave instability, in order to suppress or avoid the formation of the larger droplets. In Fig. 2(d), the second peak is centred on about 40 μ m. Therefore the diameter of the cavities can be controlled to be less than 40 μ m. This indeed will show a performance in which the larger droplets are suppressed. The inventors also report that the drop formation requires deformations of the surface that are of a scale larger than the drop size. Fig. 4 for example shows that cavities of diameter 80 μ m still prevent the bigger drops. Further results (not shown) have demonstrated that cavities up to 200 μ m in diameter can also prevent these secondary drops.

[0100] In the schematic view shown in Figs. 1A and 1B, the cavities 16 have a shape which is substantially hemispherical. This is intended to be illustrative. Hemispherical cavities can be

used. However, more generally, cavities of other shapes can be used, e.g. cylindrical cavities, rectangular or square cylindrical cavities, circular cylindrical cavities, etc. Such cavities can have closed bottom ends. The bottoms of such cavities can be flat or rounded. In the case of etched cavities, some rounding of the bottoms is typical. In other embodiments, the cavities may have more complex internal structures. Examples are shown in Figs. 5-10.

[0101] Fig. 5 shows a schematic cross sectional view of a single cavity 40. The cavity has a closed bottom 42, internal walls 44, 46 and an upstanding pillar 48. Pillar 48 is supported on the closed bottom 42. In the cavity of Fig. 5, it is intended that the plan view shape of the cavity is a square, with the pillar formed at the centre. In alternative embodiments, the plan view shape of the cavity may be rectangular, other polygonal shape, round or circular. In those cases, it is possible for the pillar to be located at the geometrical centre of the shape, or located off-centre.

[0102] Fig. 6 shows a schematic cross sectional view of a single cavity 60 which is a modification of the cavity shown in Fig. 5. Here, the internal walls 64, 66 and the pillar 68 have an array of projections 67. The projections are arranged based on a periodic arrangement with the intention of interacting phononically with SAWs and affecting the transmission, distribution or other properties of the SAWs in the cavity. In this way, a phononic structure 69 is formed.

[0103] Fig. 7 shows a schematic cross sectional view of a single cavity 80 which is another modification of the cavity shown in Fig. 5. The cavity has an open bottom 82, internal walls 84, 86 and an upstanding pillar 88. Since there is no closed bottom to support pillar 88, it is supported by an arrangement of struts 90 extending from the internal walls 84, 86. As for the cavity of Fig. 5, it is intended that the plan view shape of the cavity is a square, with the pillar formed at the centre. In alternative embodiments, the plan view shape of the cavity may be rectangular, other polygonal shape, round or circular. In those cases, it is possible for the pillar to be located at the geometrical centre of the shape, or located off-centre.

[0104] Fig. 8 shows a plan view of the cavity of Fig. 7.

[0105] Fig. 9 shows a schematic cross sectional view of a single cavity 100 which is a modification of the cavity shown in Fig. 8. Here, the internal walls 104, 106 and the pillar 108 have an array of projections 107. The projections are arranged based on a periodic arrangement with the intention of interacting phononically with SAWs and affecting the transmission, distribution or other properties of the SAWs in the cavity. In this way, a phononic structure 109 is formed. Pillar 108 is supported by struts 110.

[0106] Fig. 10 shows a plan view of the cavity of Fig. 9.

[0107] The use of complex cavity structures allows the interaction of the SAWs with the liquid to be controlled further. This is achieved by consideration of interaction of the fluid with the additional structures and by consideration of the interaction of the SAWs with the additional structures.

[0108] Additional investigation has been carried out to assess the effect of cavity size (also referred to herein as pore size) on aerosol droplet size. Cavities of different diameter were etched into silicon superstrates. The cavities were etched cylindrical pits with a closed bottom end, approximately 300 μm deep. Using blind cavities in this way did not allow a continuous feeding of the cavities with liquid. As a result, for each experiment, only a small volume could be nebulised at a time. For this reason, rather than carrying out an analysis of the particle size distribution based on light diffraction, as reported above, here the results are reported based on a visual observation of a small number of drops in the nebulised plumes (based on recorded microvideograph footage of the nebulised plumes).

[0109] Initially, a drop of water was placed on top of each superstrate and SAW was applied until the top layer of water disappears (either evaporate or nebulised), leaving water only in the cavities without there being liquid communication between the cavities (no water present on the surface of the superstrate between the cavities). Nebulisation from the cavities was then monitored using a fast camera (>250kfps) fixed to a microscope, enabling the recording of images.

[0110] The largest droplets nebulised from the pores were visually assessed for their diameters.

[0111] The results are shown in Fig. 11. Figs 12, 13 and 14 show images from the recorded footage, with Fig. 12 showing a superstrate with cavities of diameter 80 μm , Fig. 13 showing cavities of diameter 600 μm and Fig. 14 showing cavities of diameter 1500 μm . For each, the SAW was excited at 13.93MHz and -5dBm. The series of images was analysed and largest droplets were measured. Note that to estimate droplet size from the 80 μm cavities, the thickness of the plume were divided by the number of droplets (3 to 4 droplets) and for holes with 600 and 1500 μm diameter, single droplets were measured. For the 80 μm cavities, this was because the plume was so condensed that no single droplet could be measured.

[0112] Fig. 11 shows the variation in droplet size with cavity diameter. This shows an increase in droplet size as the cavity diameter is increased. However, the change in droplet size is not as significant as expected, but this is likely to be due to the measurement approach. Measurement of the droplet diameter distribution using light scattering in a continuous plume would demonstrate a shift in droplet size distributions, in which for small cavities (80 μm diameter), only small drops are present (<10 μm), whereas for larger cavities (1500 μm diameter), small drops are still seen, but other modes also exist to provide droplets also of large diameter (about 20-50 μm mean size). The results reported here indicate an effect attributable to the cavity diameter and correlate with the theory outlined, which is that the pinned surface layer within pores is ruled by the meniscus curvature (i.e. contact angle with pore wall). This results in a surface rigidity, suppressing capillary waves.

List of non-patent literature references:

[0113]

P. P. H. L. Brun, A. H. de Boer, H. W. Frijlink, and H. G. M. Heijerman, *Pharm. World Sci.*, 2000, 22, 75-81.

J. Boe, J. H. Dennis, B. R. O'Driscoll, T. T. Bauer, M. Carone, B. Dautzenberg, P. Diot, K. Heslop, and L. Lannefors, *Eur. Respir. J.*, 2001, 18, 228-242.

M. B. Dolovich and R. Dhand, *The Lancet*, 2011, 377, 1032-1045.

J. Reboud, R. Wilson, Y. Zhang, M. H. Ismail, Y. Bourquin, and J. M. Cooper, *Lab. Chip*, 2012, 12, 1268-1273.

J. Reboud, Y. Bourquin, R. Wilson, G. S. Pall, M. Jiwaji, A. R. Pitt, A. Graham, A. P. Waters, and J. M. Cooper, *Proc. Natl. Acad. Sci.*, 2012, 109, 15162-15167.

A. Qi, L. Y. Yeo, and J. R. Friend, *Phys. Fluids*, 2008, 20, 074103.

M. Kurosawa, T. Watanabe, A. Futami, and T. Higuchi, *Sens. Actuators Phys.*, 1995, 50, 69-74.

M. Kurosawa, A. Futami, and T. Higuchi, in *Solid State Sensors and Actuators, 1997. TRANSDUCERS '97 Chicago.*, 1997 International Conference on, 1997, vol. 2, pp. 801-804.

M. Alvarez, J. Friend, L. Yeo, and D. Arifin, in *16th Australasian Fluid Mechanics Conference, 2007*, pp. 621-624.

J. Ju, Y. Yamagata, H. Ohmori, and T. Higuchi, *Sens. Actuators Phys.*, 2008, 145-146, 437-441.

J. Ju, Y. Yamagata, K. Inoue, and T. Higuchi, in *Service Robotics and Mechatronics*, eds. K. Shirase and S. Aoyagi, Springer London, 2010, pp. 309-312.

M. N. Topp, *J. Aerosol Sci.*, 1973, 4, 17-25.

A. Qi, J. R. Friend, L. Y. Yeo, D. A. V. Morton, M. P. Mcintosh, and L. Spiccia, *Lab. Chip*, 2009, 9, 2184.

N. Maehara, S. Ueha, and E. Mori, *Rev. Sci. Instrum.*, 1986, 57, 2870-2876.

Wu, T. & Chang, I., 2005. Actuating and detecting of microdroplet using slanted finger interdigital transducers. *Journal of Applied Physics*, 98(2), 024903-7

H. Eixarch, E. Haltner-Ukomadu, C. Beisswenger and U. Bock, *Drug Delivery to the Lung: Permeability and Physicochemical Characteristics of Drugs as the Basis for a Pulmonary Biopharmaceutical Classification System (pBCS)*, *Journal of Epithelial Biology & Pharmacology*, 2010, 3, 1-14.

J. Blamey, L.Y. Yeo, and J.R. Friend, *Microscale Capillary Wave Turbulence Excited by High Frequency Vibration*, *Langmuir* 2013, 29, 3835-3845.

REFERENCES CITED IN THE DESCRIPTION

This list of references cited by the applicant is for the reader's convenience only. It does not form part of the European patent document. Even though great care has been taken in compiling the references, errors or omissions cannot be excluded and the EPO disclaims all liability in this regard.

Patent documents cited in the description

- [WO2012096378A \[0006\] \[0009\]](#)
- [WO2011023949A \[0009\] \[0032\] \[0066\] \[0075\]](#)
- [WO2011060369A \[0009\] \[0032\] \[0066\] \[0075\]](#)
- [WO2012114076A \[0009\] \[0032\] \[0066\] \[0075\]](#)
- [WO2012156755A \[0009\] \[0032\] \[0066\] \[0075\]](#)

Non-patent literature cited in the description

- **P. P. H. L. BRUNA. H. DE BOERH. W. FRIJLINKH. G. M. HEIJERMAN**Pharm. World Sci., 2000, vol. 22, 75-81 [\[0113\]](#)
- **J. BOEJ. H. DENNISB. R. O'DRISCOLLT. T. BAUERM. CARONEB. DAUTZENBERGP. DIOTK. HESLOPL. LANNEFORSE**Eur. Respir. J., 2001, vol. 18, 228-242 [\[0113\]](#)
- **M. B. DOLOVICH. R. DHANDT**The Lancet, 2011, vol. 377, 1032-1045 [\[0113\]](#)
- **J. REBOUDR. WILSONY. ZHANGM. H. ISMAILY. BOURQUINJ. M. COOPER,** Lab. Chip, 2012, vol. 12, 1268-1273 [\[0113\]](#)
- **J. REBOUDY. BOURQUINR. WILSONG. S. PALLM. JIWAJIA. R. PITTA. GRAHAMA. P. WATERSJ. M. COOPER**Proc. Natl. Acad. Sci., 2012, vol. 109, 15162-15167 [\[0113\]](#)
- **A. QI, L. Y. YEOJ. R. FRIEND**Phys. Fluids, 2008, vol. 20, 074103- [\[0113\]](#)
- **M. KUROSAWAT. WATANABEA. FUTAMIT. HIGUCHI**Sens. Actuators Phys., 1995, vol. 50, 69-74 [\[0113\]](#)
- **M. KUROSAWAA. FUTAMIT. HIGUCHI**Solid State Sensors and Actuators, 1997, [\[0113\]](#)
- International Conference on **TRANSDUCERS '97** Chicago., 1997, vol. 2, 801-804 [\[0113\]](#)
- **M. ALVAREZJ. FRIENDL. YEOD. ARIFIN**16th Australasian Fluid Mechanics Conference, 2007, 621-624 [\[0113\]](#)
- **J. JUY. YAMAGATAH. OHMORIT. HIGUCHI**Sens. Actuators Phys., 2008, 145-146437-

441 [0113]

- **J. JUY. YAMAGATAK. INOUE. HIGUCHI**Service Robotics and MechatronicsSpringer20100000309-312 [0113]
- **M. N. TOPP**J. Aerosol Sci., 1973, vol. 4, 17-25 [0113]
- **A. QIJ. R. FRIENDL. Y. YEOD. A. V. MORTONM. P. MCINTOSHL. SPICCIA**Lab. Chip, 2009, vol. 9, 2184- [0113]
- **N. MAEHARAS. UEHAE. MORI**Rev. Sci. Instrum., 1986, vol. 57, 2870-2876 [0113]
- **WU, T.CHANG,** IActuating and detecting of microdroplet using slanted finger interdigital transducersJournal of Applied Physics, 2005, vol. 98, 2024903-7 [0113]
- **H. EIXARCHE. HALTNER-UKOMADUC. BEISSWENGERU. BOCK**Drug Delivery to the Lung: Permeability and Physicochemical Characteristics of Drugs as the Basis for a Pulmonary Biopharmaceutical Classification System (pBCS)Journal of Epithelial Biology & Pharmacology, 2010, vol. 3, 1-14 [0113]
- **J. BLAMEYL.Y. YEOJ.R. FRIEND**Microscale Capillary Wave Turbulence Excited by High Frequency VibrationLangmuir, 2013, vol. 29, 3835-3845 [0113]

Patentkrav

1. Indretning til fremstilling af forstøvede dråber, hvor indretningen har:
en transmissionsoverflade til overfladelydbølger (SAW);
en SAW-transducer (10), der er indrettet til at generere og udbrede SAW'er
5 langs SAW-transmissionsoverfladen; og
en række hulrum (16), der åbner sig på SAW-transmissionsoverfladen for at
kunne indeholde en væske, hvor hulrummene har en dybderetning, der er vin-
kelret på SAW-transmissionsoverfladen,
10 hvor, når de er i funktion, SAW'er, der udbreder sig langs SAW-transmissions-
overfladen, interagerer med væsken i hulrummene (16) for at producere for-
støvede dråber af væsken, **kendetegnet ved, at**
hulrummene har en maksimal dimension i en retning, der er vinkelret på dyb-
den af hulrummene på højst 500 µm.
- 15 2. Indretning ifølge krav 1, hvor SAW-transmissionsoverfladen er en overflade
af et overliggende lag (14), der er koblet til SAW-transducere (10).
3. Indretning ifølge krav 1 eller krav 2, hvor hulrummene (16) i det væsentlige
20 har forskellige former.
4. Indretning ifølge krav 1 eller krav 2, hvor hulrummene (16) danner en række
hulrum med i det væsentlige tilfældige former.
5. Indretning ifølge et af kravene 1 til 4, hvor hulrummene (16) er lukket i en
25 ende, der er distal fra SAW-transmissionsoverfladen.
6. Indretning ifølge et af kravene 1 til 5, hvor hulrummene (16) i det væsentlige
har samme dimensioner.
- 30 7. Indretning ifølge et af kravene 1 til 6, hvor rækken af hulrum (16) er en ord-
net række.
8. Indretning ifølge et af kravene 1 til 6, hvor rækken af hulrum (16) ikke har
35 en fjernorden.

- 9.** Indretning ifølge et af kravene 1 til 8, hvor den indvendige overflade af hulrummene (16) er kemisk, fysisk eller elektrisk modificeret for at understøtte, at hulrummene kan indeholde væsken.
- 5 **10.** Indretning ifølge et af kravene 1 til 9, hvor SAW-transmissionsoverfladen er kemisk, fysisk eller elektrisk modificeret for at understøtte, at hulrummene kan indeholde væsken.
- 10 **11.** Indretning ifølge et af kravene 1 til 10, hvor indretningen indbefatter en flerhed af rækker af hulrum (16), der kan anvendes til at bidrage til graden af forstøvning af væske fra indretningen.
- 15 **12.** Fremgangsmåde til fremstilling af forstøvede dråber, herunder tilvejebringelse af en indretning ifølge et af kravene 1 til 11, hvor fremgangsmåden omfatter følgende trin:
at indeholde en væske i hulrummene (16); og
at bevirke, at SAW'er udbreder sig langs SAW-transmissionsoverfladen for at interagere med væsken i hulrummene for at producere forstøvede dråber af væsken.
- 20 **13.** Fremgangsmåde ifølge krav 12, hvor, når SAW-transmissionsoverfladen vender opad, væsken er indeholdt i hulrummene (16), således at væskens frie overflade er under SAW-transmissionsoverfladens niveau.
- 25 **14.** Fremgangsmåde ifølge krav 12 eller krav 13, der yderligere omfatter trinnet med at afgive væske til forstøvning.

DRAWINGS

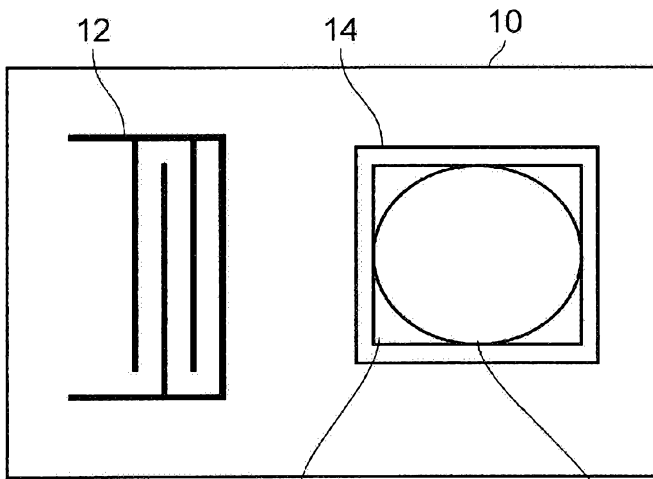

FIG. 1A

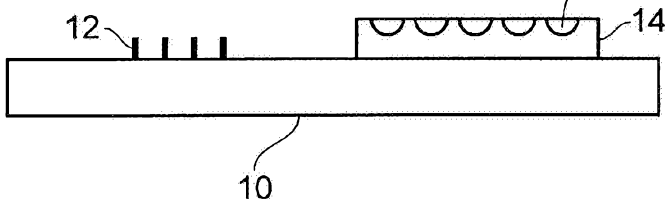

FIG. 1B

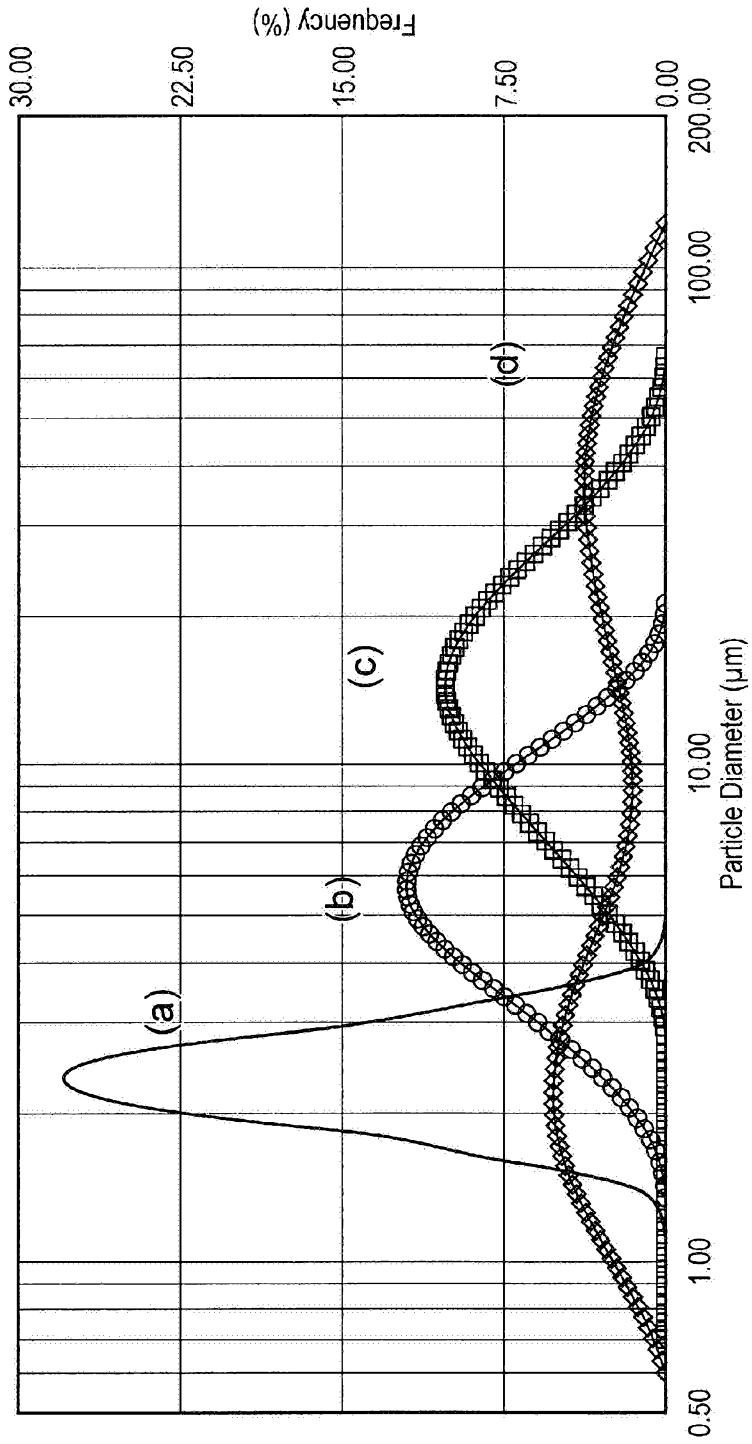

FIG. 2

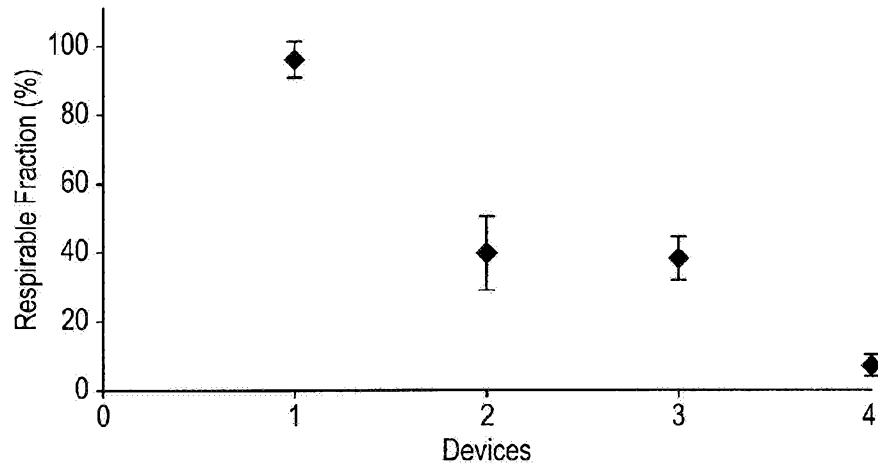

FIG. 3

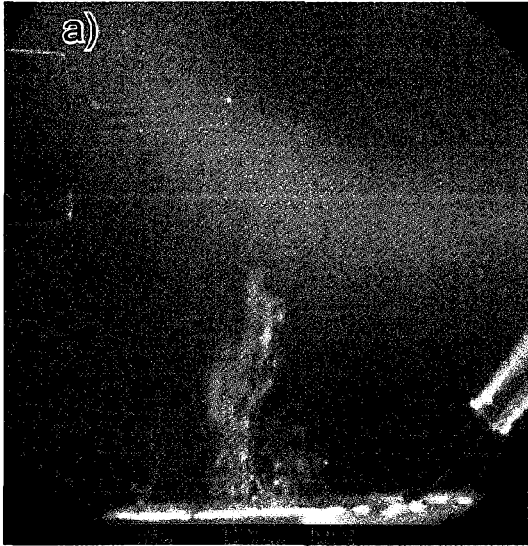

FIG. 4A

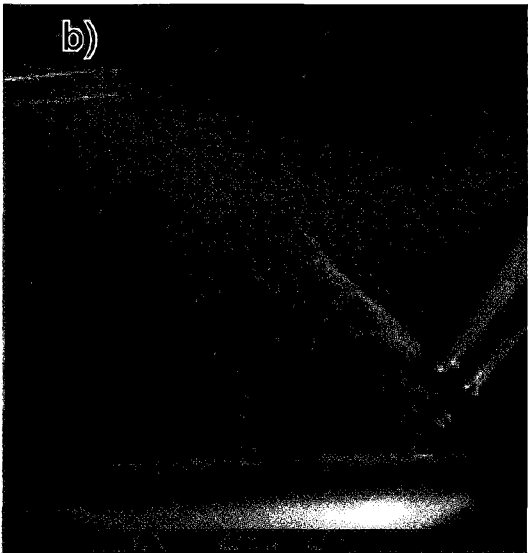

FIG. 4B

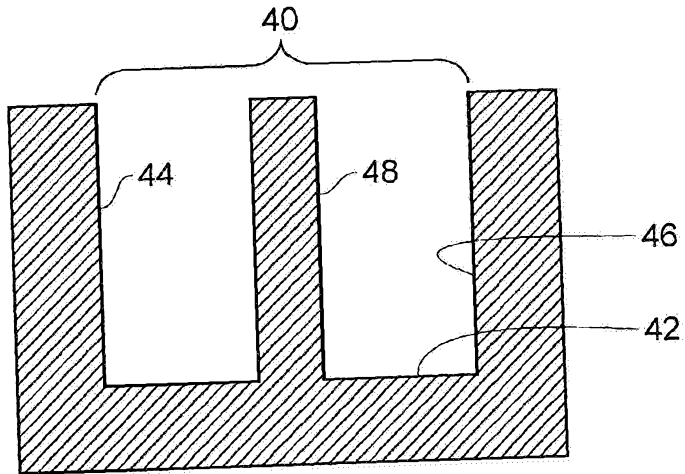

FIG. 5

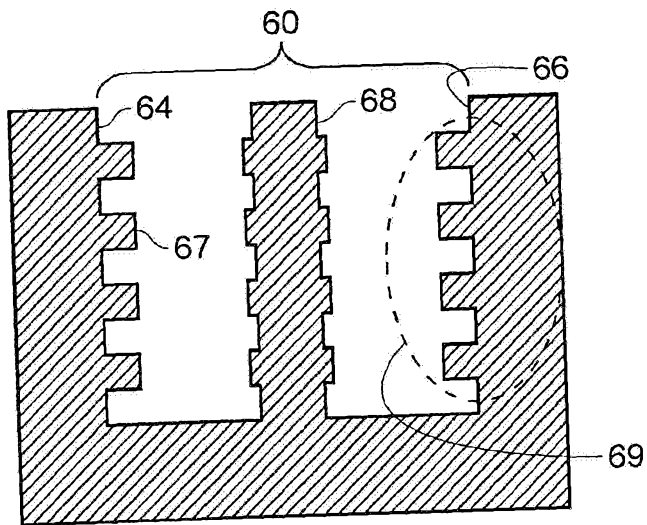
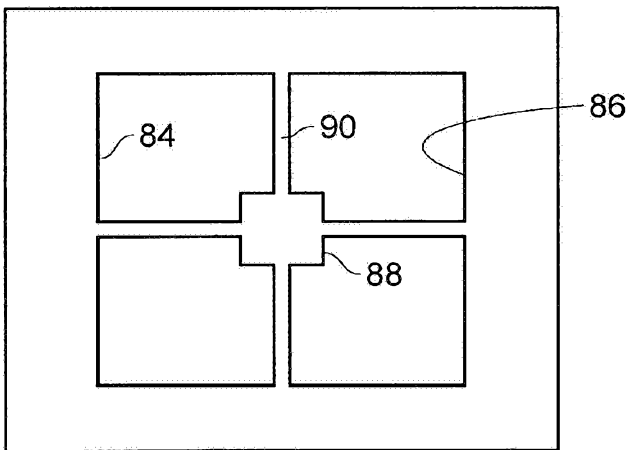
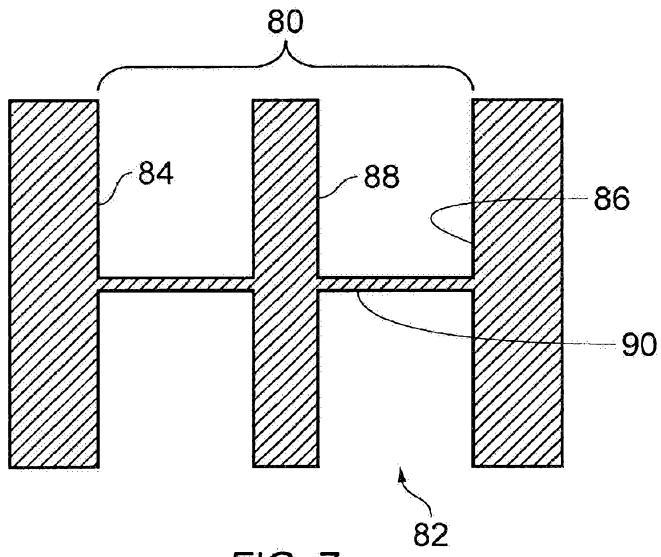

FIG. 6



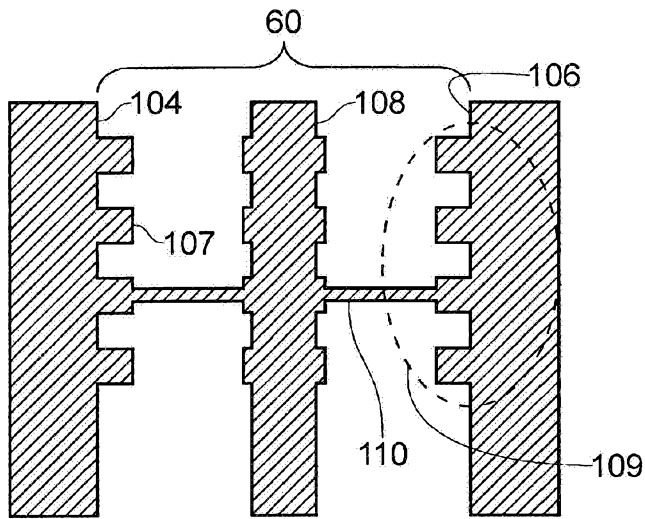

FIG. 9

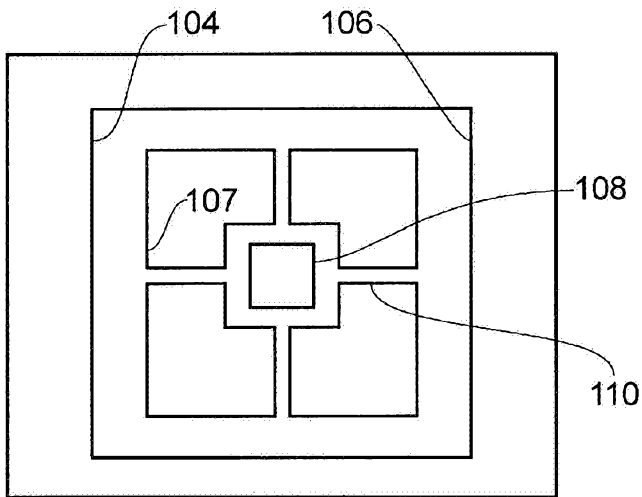

FIG. 10

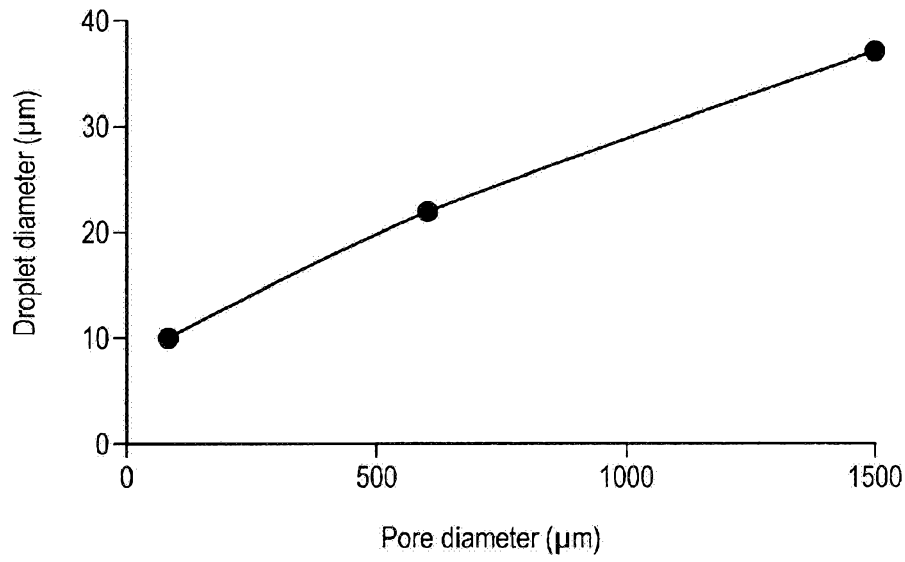

FIG. 11

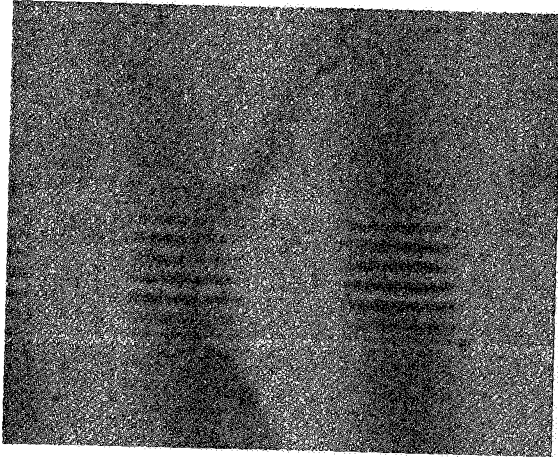

FIG. 12

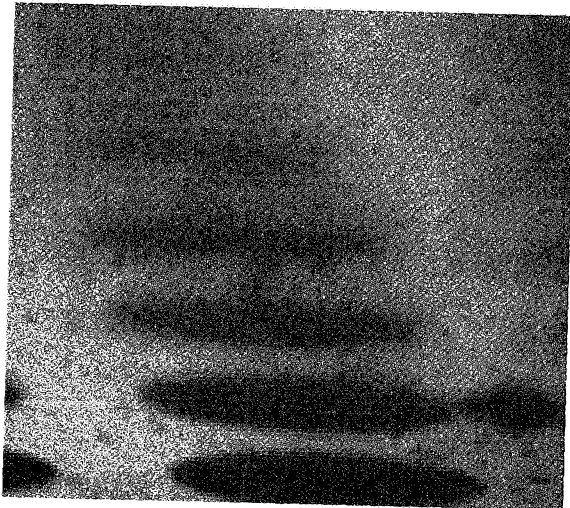

FIG. 13



FIG. 14