

Nov. 11, 1930.

1,781,289

E. J. LEVY, NOW BY JUDICIAL CHANGE OF NAME E. L. MAYO

THERMOSTATICALLY OPERATED ELECTRICAL SWITCH

Filed March 1, 1929

2 Sheets-Sheet 1

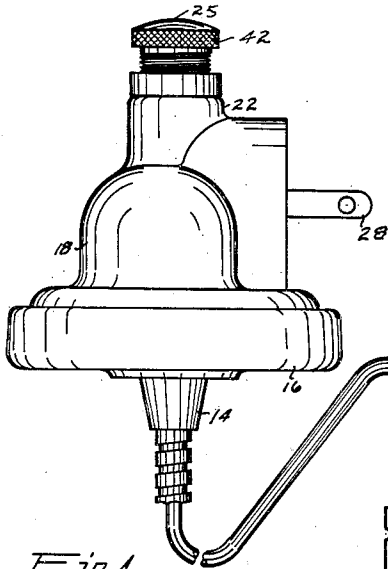

Fig. 1

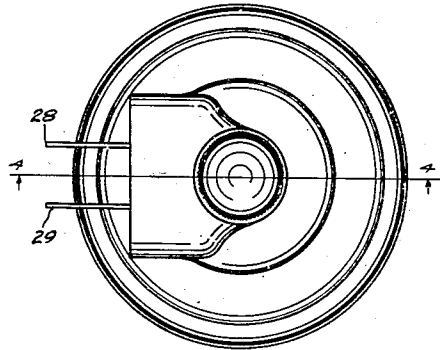

Fig. 2

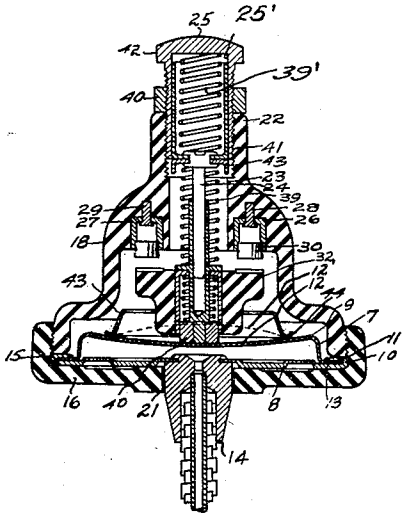

Fig. 3

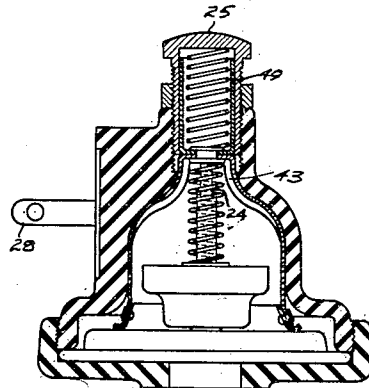
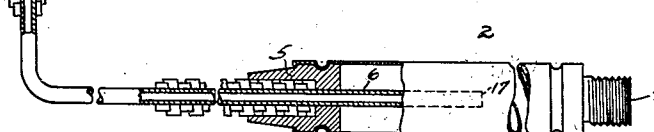

Fig. 4



Inventor

Edward J. Levy

By

Frank M. Slough

Attorney

Nov. 11, 1930.

1,781,289

E. J. LEVY, NOW BY JUDICIAL CHANGE OF NAME E. L. MAYO

THERMOSTATICALLY OPERATED ELECTRICAL SWITCH

Filed March 1, 1929

2 Sheets-Sheet 2

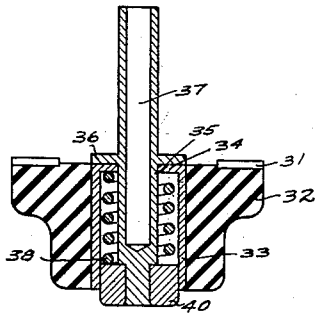

Fig. 5

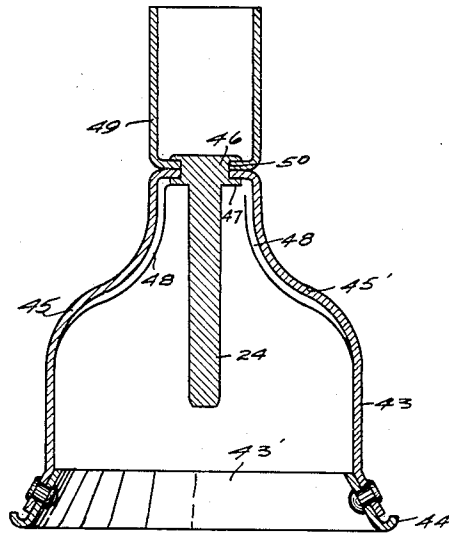

Fig. 8

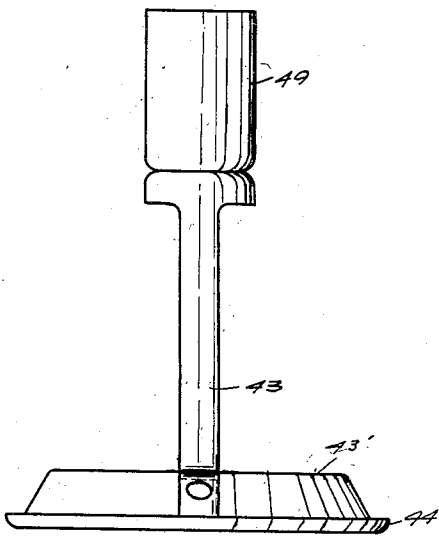

Fig. 6

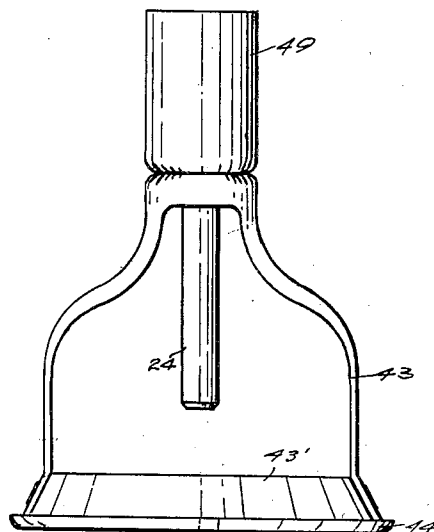

Fig. 7

Inventor
Edward J. Levy

Frank M. Slough

His Attorney

UNITED STATES PATENT OFFICE

EDWARD J. LEVY (NOW BY JUDICIAL CHANGE OF NAME EDWARD LEVY MAYO), OF CLEVELAND, OHIO, ASSIGNOR TO THE BISHOP & BABCOCK MANUFACTURING COMPANY, OF CLEVELAND, OHIO, A CORPORATION OF OHIO

THERMOSTATICALLY-OPERATED ELECTRICAL SWITCH

Application filed March 1, 1929. Serial No. 339,762.

My invention relates to thermostatic electrical switches and relates particularly to thermostatic electrical switches of the type adaptable for use in temperature regulating systems, and more particularly for use in a refrigeration system.

An object of my invention is to provide for the positive operation of an electric switch immediately when a predetermined change of temperature is effected.

Another object of my invention is to provide a switch in which all of the movable parts may be very inexpensively assembled together and which will require no careful or frequent adjustment in order to insure that the electrical switch elements thereof will properly operate.

Another object of my invention is to provide a relatively inexpensive switch mechanism of the class described but which will be very positive in operation and reliable in use, and which may be easily and accurately adjusted after assembly, to predetermine the limited temperatures at which the device may be operated.

Another object of my invention is to provide an improved thermostatically operable electrical switch of the class described, which may be manufactured in quantities to completely assembled condition, and which may thereafter be individually readjusted to effect operation of any of the switches or all of them at certain predetermined desired temperatures.

Another object of my invention is to provide an improved electrical switch mechanism which may be actuated and retracted thermostatically at terminal temperatures or a given range of temperature, and to provide improved means for predetermining such range and terminal temperatures.

Another object of my invention is to provide for the adjustment of a thermostatic electrical switch of the class above described, in which the electrical contact elements thereof are enclosed in a substantially fluid tight casing, and which may be adjusted from exteriorly of the casing enclosing said mechanism.

Another object of my invention is to pro-

vide for an adjustment of a thermostatic electrical switch of the class described, which is not sensitive, thus making the device easier to adjust.

Other objects of my invention and the invention itself will become apparent from the following description of an embodiment of my invention and in which description reference will be had to the accompanying drawing forming a part of this specification.

Referring to the drawings:

Fig. 1 illustrates in elevation, a mechanism embodying my invention, comprising a temperature sensitive bulb, and a fluid pressure operated electrical switch together with a tubular conduit interconnecting bulb;

Fig. 2 is a plan view of the switch shown in Fig. 1;

Fig. 3 is a vertical medial sectional view of the device of Fig. 1;

Fig. 4 is a view taken on the line 4-4 of Fig. 2; and

Fig. 5 is an enlarged medial sectional view of the switch contactor;

Fig. 6 is a side elevational view of certain diaphragm adjusting parts for the said embodiment;

Fig. 7 is a similar view taken at right angles to the view of Fig. 6; and

Fig. 8 is an enlarged vertical medial sectional view of the diaphragm adjusting element.

Referring now to the different figures of drawing, in all of which like parts are designated by like reference characters, the temperature-sensitive bulb, illustrated at 2, may be of any approved design, and is adapted to contain a quantity of a fluid, such as ether, mercury or the like, adapted to be expanded when heated and contracted when cooled. After the fluid is placed into the bulb, the bulb is sealed in any suitable way, such as by soldering the inlet opening 3, or by providing a cap for the inlet opening, or both.

Through the end wall 5 of the bulb, is projected a tubular conduit 6 having an open end 17, and adapted to communicate the effects of fluid pressure existing in the bulb 2 to a fluid pressure expansible call 7, which,

in the embodiment illustrated, comprises a pair of formed discs 8 and 9 secured together at their edges. Both the forms of the discs may be varied somewhat. In the embodiment illustrated, the disc 9 is in the form of a shallow saucer having a rim flange 10 with a reentrant wall 12, and the disc 8 is more nearly planular with annular stiffening grooves, preferably provided intermediate its center and its rim.

The discs are preferably secured together by enfolding the rim flange 10 of the disc 9 by an turned border portion 11 of the disc 8. The disc 9 is normally dished inwardly in its central portion 12 but is adapted to reverse the direction of dishing whenever the pressure within the cell 7 exceeds a predetermined pressure, as indicated by the dotted lines 12'. Preferably an annular fillet 13 of solder will hermetically seal the cell in its edge portions. A coupling element 14 serves to effect communication between the tube 6 and the interior of the cell 7.

The cell thus formed is adapted to be clamped between an annular shoulder 15 of a cup-shaped casing cap 16, and the annular edge surface of a cup-shaped casing 18, the cap being secured to the casing by interengaging screw threaded portions of the cap and casing, respectively, and the cell by its peripheral flange comprising the disc flanges 10 and 11, is tightly clamped therebetween.

The coupling element 14 which is riveted to the walls of the disc 8, surrounding the central opening therein, projects through a central opening 21 of the cap. The cap and casing are preferably made of phenolic condensation material and the casing comprises a stem portion 22 initially provided with a central bore 23, adapted to receive the exterior threaded skirt 41 of a knurled adjusting screw 25, which screw is provided with a central bore 25' extending through most of its length and is adapted to be adjustably screw threaded into the bore 23 to adjustably compress a pair of helical springs in a manner later to be more fully explained. The adjusting screw may be locked in any adjusted position by the lock nut 40.

At 26 and 27, electrical contact supporting metallic caps project forwardly toward the mouth of the casing, which contains the cell 7, and have their base portions embedded, during the molding of the casing, in the molding material thereof. Like spaced metallic electrical terminals 28 and 29, likewise secured to the contact supports 26 and 27, respectively, and preferably project through a wall of the casing for connection to electrical contacts of an electrical plug socket, not shown.

Metallic electrical contact pieces 30 are rigidly supported by the contact supporting caps 26 and 27, being preferably driven tightly within the projected open ends of the

caps. The contacts 30 are, therefore, rigidly mounted in the casing on opposite sides of a guide rod 24, and are spaced therefrom.

A reciprocable contact ring or switch blade 31 of annular form carried on a bored insulating block 32, is adapted to be axially moved by the block to span the contacts 30 to make an electrical circuit connection between them. A bushing 33 is secured within the bore of the block, and is provided at one end with an annular inwardly extending flange 34, through which extends a relatively reciprocable stem 35 having an annularly radially extending flange 36 and is provided at its one end with a piston head or button 40.

The flange 36 is engageable with the bushing flange 34 and a spring 38 is interposed between the inner surface of the flange and the inner surface of the flanged head or button 40. The stem 35 is provided with an axial bore 37 extending throughout most of its length, adapted to receive the guide rod 24, loosely projected therein.

At 43 I show an adjustably reciprocable diaphragm adjusting element, the upper portion of which comprises a guide cup 49 which is provided with an aperture 50 in its end wall. The lower portion comprises a pair of reversely curved bridge pieces 45 and 45' which support at their lower ends a frustro conical ring 43' having an outwardly curved rim flange 44. The bridge pieces and the cup are securely held together against each other by the head 46 of the guide pin 24, the head being provided with an annular flange 47 which contacts with the ends of the bridge pieces, the upper end of the head being telescoped in the aperture 50 and the portion projecting beyond the end wall being spun or riveted over against the inner end wall of the cup. The bridge pieces are strengthened adjacent their upper ends by transversely curved portions 48 which make the bridge pieces substantially channel shaped at this portion.

The guide cap 49 is adapted to be slidably telescoped in the bore of the adjusting screw and a spring 39' is disposed in the recess formed by the cup and adjusting screw, exerting pressure on the inner end wall of the screw and the inner end wall of the cup to force the diaphragm adjusting element downward so that the curved flange 44 contacts with the cell 7.

The switch blade supporting block 32 is interposed between the diaphragm and the bridge of the diaphragm adjusting element 43 the hollow stem 35 being telescoped over the guide rod 24.

The stem 35 is reciprocable on the guide rod 24 against the pressure of the spring 39 disposed about the stem and guide rod. When pressure is exerted on the rounded button end 40 of the stem, the spring 39 will first yield to permit axial movement of the

block 32, but without substantial relative movement of the stem 35 and the insulating block 32.

However, upon engagement of the switch blade 31 with the rigidly mounted contacts 30, the pressure exerted upon the button end of the stem 35 will effect a telescopic movement of the stem relative to the button and switch blade. The pressure of contact had between the blade 31 and the contacts 30, bridged thereby, will be therefor resiliently maintained.

The stem 35 intermediate its flange 36 and head 40 is preferably made sufficiently small in diameter as to permit a certain amount of lateral movement of the bushing flange 34 and the stem and in order that the block may tilt and/or move laterally, sufficiently to insure positive contact being had between the blade and both, or all, of the contacts 30 at all times, independently of the precise levels to which said contacts project, and independently of any lack of axial alignment provided in manufacture between the stem 35 and the axis of the casing 18.

Further lateral movement of the block is permitted by making the guide rod 24 slightly smaller than the bore 37 to provide a slight clearance space therebetween. The block, comprising within the term also the stem 35 and associated parts, is placed in the casing with the stem 35 telescoped over the rod 24, the rounded button end 40 of the stem being disposed in contact with the central portion of the dished disc 9 of the cell 7, the diaphragm adjusting mechanism, comprising the element 43, being first disposed in the casing between the block 32 and upper end of the casing and the adjusting screw 25, and the springs 39' and 39 disposed as shown.

The mechanism assembled, as illustrated in Figs. 3 and 4, operates as follows:

Upon a predetermined increase in temperature, the fluid in the bulb 2 will expand, effecting an increase of fluid pressure in the bulb, the tube 6, and the cell 7, until at a predetermined temperature, the inwardly dished disc 9 will suddenly reverse its direction of dishing to approximately the position illustrated by the dotted line in Fig. 3, and the force effected thereby, being a powerful one, because of the amount of potential energy previously stored in the expansion cell because of the resistance offered by the disc reversal of its form, the stem 35 by the engaged button 40, will be projected axially to move the block 32 axially of the casing to effect positive resilient pressure maintained engagement between the annular metallic switch blade 31 and the metallic electrical contact pieces 30, to effect an electrical connection between the terminals 28 and 29.

The spring 38 will be compressed a certain amount, depending upon the amplitude of axial movement of the central portion 12 of

the disc 9, and the pressure of the spring 38 will, therefore, be effective to effect a more positive contact between the blade 31 and the contacts 30.

Upon a predetermined lower pressure being subsequently effective upon the bulb 2, the reverse action will take place, and the disc 12 will be suddenly restored to its reentrant dished form, and the spring 39, will be effective to assist in its return to such form, accomplishing altogether a very abrupt and practically instantaneous "opening" of the contacts to break the circuit previously closed by the engagement of the blade 31 with the contacts 30. This switch breaking action is extremely rapid and practically eliminates all undesirable "arcing" and subsequent deterioration at the contacts, commonly had in previous switches of certain types with which I am familiar, and accomplishes a degree of efficiency in operation not previously had in switches of this character, except those of more expensive construction.

From the foregoing description it will be apparent that rotation of the adjusting screw 25 by the knurled flange 42, will increase or diminish the pressure of the spring 39 together with the diaphragm adjusting element upon the surface of the disc 9, and will effect engagement between the rim 44 and the diaphragm disc 9 along a circular line of contact. The engagement between the rim flange 44 of the annulus and the diaphragm disc 9 is had along a circular line concentric with the center of the disc and spaced inwardly from the shoulder 56 thereof, being preferably disposed about one-fourth of the distance toward the center of the disc.

This precise position may be varied, however, within the purview of my invention, according to the range of adjustment required and the proportion of the elements involved.

Substantially continuous engagement between the rim flange 44 of the adjusting element and the diaphragm 9, is had all around the rim flange. Slight axial readjustment of the elements 43 may be accomplished when pressure is applied thereto through its tubular stem 49 by the adjusting screw, causing it to press against the diaphragm. The diaphragm being concave on its surface engaged by the rim flange 44, tends to centralize the annulus 43 pressed against it.

The effect of pressure engagement between the annulus 43 and the diaphragm, along the circular line of contact, as above described, is to reinforce the resistance normally effective to movement of the diaphragm outwardly to cause it to take the convex form, and to effect retraction of the diaphragm to its normally concave form (viewed from its exterior side) upon a subsequent decrease in temperature, less than would otherwise be required.

Although the apparatus of my invention is operable by variations in pressure of fluid introduced into the cell 7, accomplished in any manner, it is very adaptable for operation under the control of variations in fluid pressures thermally effected by such means as thermal expansion and contraction of an expandable fluid placed within the bulb 2. In either operative position, the central portion of the disc 9 resists change to the alternative form and may be made to be more stable in the one direction than in the other direction.

For instance, with a given bulb fluid "fill" and a given relatively slight normal pressure contact between the rim of the annulus 43 and the electrical contacts 30 by the switch blade 31 by expansion of the fluid in the bulb, at a temperature of 25° Fahrenheit.

The contacts will reopen by a sudden return of the diaphragm 9 to its original dished form at 7 degrees Fahrenheit.

With the adjusting screw 25 advanced inwardly relative to the casing to increase the pressure of contact had between the flange 44 of the annulus 43, and the diaphragm, other conditions remaining unchanged, the same mechanism may be operated to effect bridging of the contacts at, say, about 30° Fahrenheit, and sudden reopening of the contacts at about 20° Fahrenheit.

It is to be noted in the above example, that the outward movement of the diaphragm, is effected at a given increase in temperature upon increased pressure by the element 43, which is less than the increase in temperature at which the diaphragm will return to its original concave form.

This is of considerable advantage, especially where the mechanism is used to control refrigerating mechanisms, since under given conditions of filling, etc., the range of temperatures covered by the opposite operations of the device, may be made wider for controlling mechanisms controllable at lower temperatures and narrower for those controllable at temperatures more nearly approximating the freezing point of water, so that refrigerating mechanisms desiring a close regulation of temperature near freezing point of water, may be served by a device made originally to operate covering a greater range of lower temperatures.

Having thus described my invention in a particular embodiment, I am aware that numerous and extensive departures may be made from the embodiment herein illustrated and described but without departing from the spirit of my invention.

I claim:

1. In a fluid pressure operated switch mechanism, the combination with a fluid pressure cell comprising a pair of discs, means securing the discs together in fluid tight engagement at their edges, one of said discs being constrained by said means to a

concavo-convex form, a casing within which the disc is secured, an electrical switch mechanism disposed within the casing, said mechanism comprising a switch operating element longitudinally reciprocable relative to the axis of the cell, and a spring pressing said element against the central portion of the concavo-convex disc, said cell being adapted to contain a fluid under varying conditions of pressure thereof, and to change the direction of its concavo-convexity responsive to pressure above a predetermined value, and means to vary the said predetermined value, said means comprising an annulus engageable with the exterior surface of the concavo-convex disc, intra-peripherally thereof, a pair of thrust elements diametrically engaging the annulus, and means for exerting thrust on the elements axially of the annulus.

2. In a fluid pressure operated switch mechanism, the combination with a fluid pressure cell comprising a pair of discs, means securing the discs together in fluid tight engagement at their edges, one of said discs being constrained by said means to a concavo-convex form, a casing within which the disc is secured, an electrical switch mechanism disposed within the casing, said mechanism comprising a switch operating element longitudinally reciprocable relative to the axis of the cell, and a spring pressing said element against the central portion of the concavo-convex disc, said cell being adapted to contain a fluid under varying conditions of pressure thereof, and to change the direction of its concavo-convexity responsive to pressure above a predetermined value, and means to vary the said predetermined value, said means comprising an annulus engageable with the exterior surface of the concavo-convex disc, intra-peripherally thereof, and means to adjustably vary the contact pressure between said annulus and said concavo-convex disc comprising a plurality of thrust elements engaging the annulus and extending axially therefrom and means for adjustably applying pressure on the thrust elements.

3. In a fluid pressure operated switch mechanism, the combination with a fluid pressure cell comprising a pair of discs, means securing the discs together in fluid tight engagement at their edges, one of said discs being constrained by said means to a concavo-convex form, a casing within which the disc is secured, an electrical switch mechanism disposed within the casing, said mechanism comprising a switch operating element longitudinally reciprocable relative to the axis of the cell, and a spring pressing said element against the central portion of the concavo-convex disc, said cell being adapted to contain a fluid under varying conditions of pressure thereof, and to change the direction of its concavo-convexity responsive to pressure above a predetermined value, and means to

vary the said predetermined value, said means comprising an annulus engageable with the exterior surface of the concavo-convex disc, intra-peripherally thereof, and means to adjustably vary the contact pressure between said annulus and said concavo-convex disc, said adjustable means comprising an adjustment element screw threaded through a wall of the casing, a spring interposed between said adjustment element and said annulus, said annulus being resiliently axially movable, upon rotation of said screw, through said spring, from the exterior of the casing.

In testimony whereof I hereunto affix my signature this 12th day of February, 1929.

EDWARD J. LEVY,

Now by Judicial Change of Name Edward Levy Mayo.

4. In a fluid pressure operated switch mechanism, the combination with a fluid pressure cell comprising a pair of discs, means securing the discs together in fluid tight engagement at their edges, one of said discs being constrained by said means to a concavo-convex form, a casing within which the disc is secured, an electrical switch mechanism disposed within the casing, said mechanism comprising a switch operating element longitudinally reciprocable relative to the axis of the cell, and a spring pressing said element against the central portion of the concavo-convex disc, said cell being adapted to contain a fluid under varying conditions of pressure thereof, and to change the direction of its concavo-convexity responsive to pressure above a predetermined value, and means to vary the said predetermined value, said means comprising an annulus resiliently engageable with the exterior surface of the concavo-convex disc, intra-peripherally thereof, and means to adjustably vary the contact pressure between said annulus and said concavo-convex disc, said adjustable means comprising an adjustment element screw threaded through a wall of the casing, a spring interposed between said adjustment element and said annulus, said annulus being axially movable upon rotation of said screw from the exterior of the casing.

5. In a fluid pressure operated switch mechanism, the combination with a fluid pressure cell comprising a pair of discs, means securing the discs together in fluid tight engagement at their edges, one of said discs being constrained by said means to a concavo-convex form, a casing within which the disc is secured, an electrical switch mechanism disposed within the casing, said mechanism comprising a switch operating element longitudinally reciprocable relative to the axis of the cell, and a spring pressing said element against the central portion of the concavo-convex disc, said cell being adapted to contain a fluid under varying conditions of pressure thereof, and to change the direction of its concavo-convexity responsive to pressure above a predetermined value, and means to vary the said predetermined value, said means comprising an annulus engageable with the exterior surface of the concavo-convex disc, intra-peripherally thereof, and means to adjustably vary the contact pres-