

J. J. GRAFF.

Tuck-Creaser.

No. 129,128.

Patented July 16, 1872.

Fig. 1.

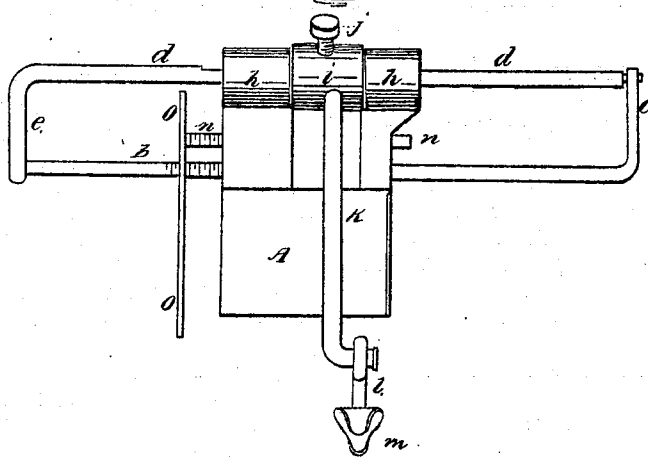
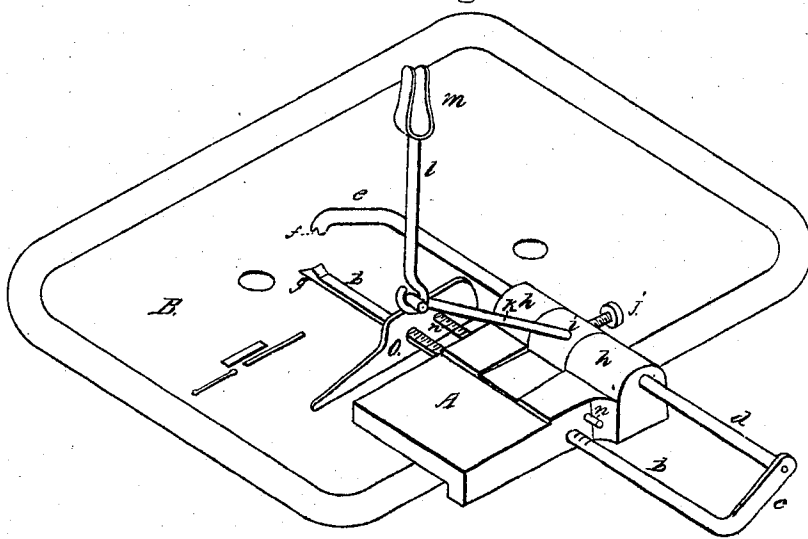

Fig. 2.



Witnesses.

J. L. Doone
George Wuest jr

Inventor.

Justin J. Graff
per Dewey &
attys

UNITED STATES PATENT OFFICE.

JUSTIN J. GRAFF, OF SAN FRANCISCO, CALIFORNIA, ASSIGNOR TO HIMSELF
AND FRANÇOIS SMITH, OF SAME PLACE.

IMPROVEMENT IN TUCK-CREASERS FOR SEWING-MACHINES.

Specification forming part of Letters Patent No. 129,128, dated July 16, 1872.

SPECIFICATION.

To all whom it may concern:

Be it known that I, JUSTIN J. GRAFF, of the city of San Francisco, in San Francisco county, State of California, have invented an Improved Tuck-Marker for Sewing-Machines; and I do hereby declare the following description and accompanying drawing are sufficient to enable any person skilled in the art or science to which it most nearly appertains to make and use my said invention and improvements without further invention or experiment.

My invention consists in a combination of certain devices for gauging the width of tucks, and also for spacing the distance between them, as hereinafter more fully described.

In order to more fully illustrate and explain my invention, reference is had to the accompanying drawing forming a part of this specification, in which—

Figure 1 is a plan. Fig. 2 is a plan, showing the attachment applied to the cloth-plate.

A represents a metal plate or casting, which is fastened by a screw upon the cloth-plate B of the machine in the usual manner, and serves to hold the gauging-rods. *b* is a rod, which passes through the plate A, and has its outer extremity bent at right angles, as shown, so as to form an arm, *c*. This rod is graduated with a scale of figures, for the purpose hereinafter mentioned. Journaled in the extremity of the bent arm *c* is the end of another rod, *d*, which also passes through the casting A, parallel to the rod *b* and at a short distance from it. The opposite extremity of this rod *d* is also bent at right angles to it, so as to form an arm, *e*. This arm is curved downward, and its extremity is provided with a groove, *f*, which interlocks or matches with an edge, *g*, on the inner extremity of the rod *b*. The plate or casting A, where the rod *d* passes through it, is constructed similar to the knuckles of a hinge, so that the rod *d* passes through two fixed knuckles, *h*, and an intermediate movable knuckle, *i*. The rod *d* is secured to the movable knuckle *i* by a set-screw, *j*, being flattened slightly upon the side against which the screw bears, and a thin piece of flat steel being interposed between the two in order to prevent the screw from scratching or indent-

ing the rod. The knuckle *i* is provided with a fixed arm, *k*, to the extremity of which is loosely secured a rod, *l*. The extremity of the rod *l* is provided with a U-shaped clasp-spring, *m*, by means of which it can be clamped upon the needle-arm of the machine. Between the rods *b* and *d* another graduated rod, *n*, passes through a hole in the plate A, parallel with the rods *b* and *d*, and has secured at its outer extremity a small vertical guide-plate, *o*. This plate is secured to the rod *n*, so that its lower edge shall extend slightly below the under side of the casting A, so that when the casting is screwed down upon the cloth-plate, the vertical guide-plate, and its rod *n* will be fixed in their positions by its pressure.

By graduating the rods *b* and *n* the operator can in an instant adjust the width of tuck to be sewed as desired, and also the space between the tucks, without trouble, and always with mathematical precision; and, should it be necessary to remove the tuck-marker before the stitching in the piece of cloth is completely finished, the set-screw *j* will preserve the space or width between the tucks, so that it will not require any further adjustment when the operation is resumed.

In operating this tuck-marker the screw *j* is loosened and the rod *b* adjusted, by means of the graduations upon it, to the width desired between the folds of the tucks, after which the set-screw is turned down. The rod *n* is then adjusted to the width of tuck desired, and the device is then firmly secured to the cloth-plate, so as to fix the guide-plate *o* in place. The rod *l* is then raised and secured to the needle-arm by means of the clamp *m*, and the device is ready for operation. The cloth to be sewed is then doubled and run through the machine, keeping the doubled edge close up against the guide-plate *o*, and as the cloth is moved along between the channeled end of the bent arm *e* and the edge *g* on the rod *b* the vibrations of the arm *e*, caused by the attachment to the needle-arm, will crease the fabric at the point where it will be necessary to fold it for the next tuck.

Having thus described my invention, what I claim, and desire to secure by Letters Patent, is—

The plate or casting A, with its adjustable

graduated rod *b*, having the arm *c* at one and the edge *g* at the other end, and the parallel rod *d*, journaled in the arm *c*, and provided with the curved arm *e*, with its channeled end, in combination with the movable knuckle *i*, its arm *k*, and the rod *l*, provided with the clasp-spring *m*, all arranged, constructed, and oper-

ating substantially as and for the purpose above described.

In witness whereof I hereunto set my hand.
JUSTIN J. GRAFF.

Witnesses:

GEORGE WUEST, Jr.,
JOHN L. BOONE.