

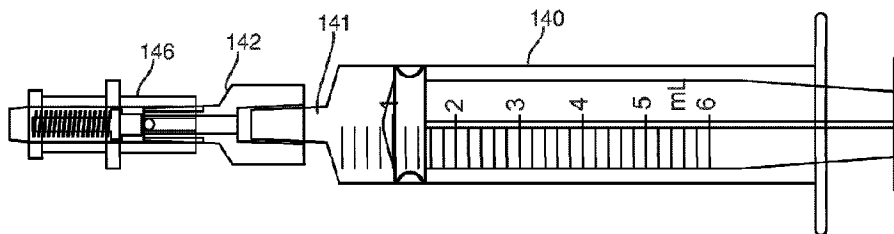

(22) Date de dépôt/Filing Date: 2012/10/22  
 (41) Mise à la disp. pub./Open to Public Insp.: 2013/04/25  
 (45) Date de délivrance/Issue Date: 2022/10/18  
 (62) Demande originale/Original Application: 2 858 303  
 (30) Priorité/Priority: 2011/10/20 (GB1118126.0)

(51) Cl.Int./Int.Cl. *A61M 25/00* (2006.01)  
 (72) Inventeurs/Inventors:  
 GLICKMAN, SCOTT, GB;  
 SHAPLAND, HOWARD, GB  
 (73) Propriétaire/Owner:  
 UROPHARMA LIMITED, GB  
 (74) Agent: GOWLING WLG (CANADA) LLP

(54) Titre :  
 (54) Title: **SYRINGE ADAPTER AND VALVE FITTING**



(57) **Abrégé/Abstract:**

A connector configured to connect a syringe to a catheter suitable for the administration of a medicament and configured to prevent the connector from being used in conjunction with standard Luer fixtures. The connector comprises two main elements. The first element is an adapter having, at a first end, a tapered recess to receive the syringe outlet. The second end of the adapter is a male connector having recessed channels and raised ribs which achieve the prevention of the fitment of the adapter to a standard Luer. The adapter is seated in a one-way valve fitting having at a first end a recess of shape complementary to that of the channels and ribs to provide a secure fitting. The raised ribs within the recess prevent a standard Luer fitting from being inserted. The second end of the valve fitting can be fitted to the instillation port of the catheter.

A connector configured to connect a syringe to a catheter suitable for the administration of a medicament and configured to prevent the connector from being used in conjunction with standard Luer fixtures. The connector comprises two main elements. The first element is an adapter having, at a first end, a tapered recess to receive the syringe outlet. The second end of the adapter is a male connector having recessed channels and raised ribs which achieve the prevention of the fitment of the adapter to a standard Luer. The adapter is seated in a one-way valve fitting having at a first end a recess of shape complementary to that of the channels and ribs to provide a secure fitting. The raised ribs within the recess prevent a standard Luer fitting from being inserted. The second end of the valve fitting can be fitted to the instillation port of the catheter.

## **SYRINGE ADAPTER AND VALVE FITTING**

### Field of the Invention

5 The invention relates to catheters for draining fluids from body cavities of human or animal subjects and especially for those catheters that can also instil a medicament into the cavity following drainage. The invention is especially concerned with such catheters for draining urine from the urinary bladder of a subject and instilling a medicament therein.

### 10 Background and Prior Art Known to the Applicant

There are a number of conditions that require patients to manually drain urine from the bladder at intervals, and this can be performed either under the supervision of an attending physician or healthcare worker, or on occasions can be performed by a patient themselves. One such  
15 common condition is an overactive bladder. For many conditions it is also necessary to deliver a medicament to the bladder. For this to be successful, it is important that the bladder is initially drained of any accumulated urine to prevent dilution of the medicament, so allowing a pre-determined dose to be applied. Direct application of medicaments to the interior of the bladder, known as “intravesical” administration is becoming more common, and one such specialised  
20 catheter to allow drainage and intravesical administration is described in UK patent GB 2448892. In this device, a

urinary cannula is described, and that comprises a number of channels extending from a proximal to a distal end of the catheter. There is a drainage channel to allow urine to flow from one end to the other; and instillation channel to allow medicament to be delivered from the proximal to the distal end and a control channel to allow a viscous control fluid to be delivered to a cuff located within the drainage channel. In some embodiments a further channel is provided to allow delivery of a fluid to a balloon adjacent to the external wall of the catheter, known as a Foley balloon, which may be inflated to secure the end of the catheter at the correct position in the bladder after insertion via the urethra.

Such devices are complex and expensive to manufacture, and it is an object of the present invention to provide an improved such catheter.

#### Summary of the Invention

Accordingly, the invention provides a catheter for insertion into a body cavity of a subject, comprising: a drainage tube extending from a drainage opening adjacent a distal end of the catheter to a drainage outlet adjacent a proximal end of the catheter; a closure member mountable for sliding movement within said drainage tube between a first position such that said drainage opening is in fluid communication with said drainage outlet and a second position wherein said closure member blocks fluid communication between said drainage opening and said outlet port; and an actuator, operable from the proximal end of the catheter, to move said closure member between said first and second positions. In this way, a simplified device is provided, having a slideable closure member, rather than an internally-mounted inflatable balloon as previously provided on such catheters. This simplifies manufacture, and also simplifies operation, as the valve closure mechanism is less likely to be confused with the other ports often seen on such catheters. This is especially important if the device is to be used by the patient themselves.

Preferably, the catheter further comprises an instillation lumen extending from an instillation port adjacent a proximal end of the catheter to an instillation outlet adjacent a distal end of the catheter. More preferably, the catheter further comprises a non-return

valve configured to resist flow in said instillation lumen in a direction from the distal end to the proximal end.

5 In preferable embodiments, said actuator is configured to move said closure member between said first and second positions irreversibly. In this way, re-use of the device is prevented, thereby reducing the risk of cross-infection.

10 In a first preferable variant, said closure member comprises a plug and said actuator comprises a filament attached to said plug, said filament extending to the proximal end of the catheter.

15 In a second preferable variant, said closure member comprises a secondary tube located within said drainage tube, said secondary tube having an aperture in its wall such that, in said first position said aperture fluidly communicates with said drainage opening and in said second position said fluid communication is blocked, and wherein said secondary tube extends to the proximal end of said catheter such that it may be manipulated to slideably move said tube between its first and second positions, thereby acting as said actuator.

20 Preferably, the second variant is configured such that said sliding movement is in an axial direction. More preferably, the cross-sectional profile of said drainage tube and the profile of the outside surface of said secondary tube are so shaped as to resist relative rotational movement therebetween whilst allowing relative axial movement therebetween.

25 In an alternative arrangement, the second variant is configured such that said sliding movement comprises rotation of said secondary tube relative to said drainage tube. Preferably, a cooperating indent and detent are provided on the outside surface of said secondary tube and the internal wall of said drainage tube configured to allow relative rotational movement between the secondary tube and the drainage tube whilst resisting  
30 relative axial movement therebetween.

In any aspect or variant of the invention it is preferred that a lubricating agent is provided between said closure member and the internal wall of said drainage tube to facilitate relative movement therebetween and/or to provide a fluid resistant seal therebetween.

- 5 In any aspect of the second variant, it is preferred that a ratchet mechanism is provided to ensure irreversible movement of the secondary tube relative to the drainage tube.

In any aspect of either variant, it is also preferred that the catheter further comprises a balloon adjacent an external wall of the catheter near its distal end and proximal of said  
10 drainage opening and connected through a balloon control channel to a balloon control port at the proximal end, the balloon being inflatable and deflatable to respectively increase and decrease the local diameter of the catheter to allow reversible anchoring of the catheter within a body cavity.

15 Brief Description of the Drawings

Figures 1 and 2 illustrate an axial cross-section of the distal end of a catheter of the present invention;

Figure 3 illustrates a transverse cross-section of a catheter of the invention;

- 20 Figures 4 and 5 illustrate transverse cross-sections of the distal end of a catheter of the invention;

Figures 6-8 illustrate transverse cross-sections of embodiments of a catheter of the invention;

- Figures 9 and 10 illustrate axial cross-sections of a distal and proximal end respectively of  
25 an embodiment of the invention;

Figures 11-13 illustrate axial cross-sections of a distal end of a catheter of the present invention; and

Figures 14-16 illustrate a delivery means for a medicament suitable for use with a catheter in accordance with the invention.

30

### Description of Preferred Embodiments

Figure 1 illustrates, in axial cross-sectional view, the distal end of a catheter of the present invention, generally indicated by 1. In this embodiment, there is provided a drainage tube 2 that extends from a drainage opening 3 adjacent the distal end 4 of the catheter to a drainage outlet adjacent a proximal end of the catheter (not illustrated). The drainage tube 2 is constructed of a flexible material, such as a silicone-based plastics material or latex. The diameter of the catheter is so sized as to be able to be introduced into a body cavity of a subject for example through a urethra. In the embodiment of figure 1 the drainage tube 2 is sealed at its distal end by a cap 5 securely fitted to the end of the tube 2.

A closure member in the form of a secondary tube 7 located within the drainage tube 2. The bore of the drainage tube 2 and the outside diameter of the secondary tube 7 are so sized as to provide a relatively snug fit, whilst allowing the secondary tube 7 to slide within the drainage tube 2 along its full length. In this embodiment, the secondary tube 7 is provided with an aperture 8 in its wall that, in a first position as illustrated in figure 1, fluidly communicates with the drainage opening 3 in the drainage tube and thus with the lumen of the secondary tube 7.

The secondary tube 7 may be slid within the drainage tube to a second position, illustrated in figure 2, such that the aperture 8 is no longer in fluid communication with the drainage opening 3 thereby blocking flow of a fluid through the drainage opening 3 and down the drainage tube or secondary tube. In the embodiment shown in figures 1 and 2, the end of the secondary tube 7 is also sealed, for example with a cap or a plug 9. In this way, if the end of the secondary tube 7 is withdrawn to a distance past the drainage opening 3 towards the proximal end of the catheter, fluid can still not flow through the drainage tube and down the secondary tube.

Also included in this embodiment is an instillation lumen 10, located within the wall of the drainage tube 2, that extends from an instillation outlet 11 adjacent the distal end 4 of

the catheter to an instillation port adjacent the proximal end of the catheter (not illustrated).

Figure 3 shows a particularly preferred configuration of this embodiment, as a transverse  
5 cross-section along the line A-A of figure 1. In this embodiment, the bore of the drainage  
tube 2 is provided with a shaped profile, in the form of a flat section 12 running the length  
of the drainage tube, and the outside surface of the secondary tube 7 is provided with a  
similarly shaped flat surface portion 13 that co-operates with the flat 12 to resist rotational  
movement of the secondary tube with respect to the drainage tube. In this way, the  
10 configuration ensures that the aperture 8 in the secondary tube can be correctly aligned  
with the drainage opening 3.

It will be appreciated that in embodiments of the catheter, multiple drainage openings 3  
may be provided around the periphery of the drainage tube, for example two such outlets,  
15 to ensure that flow can be maintained even if one outlet becomes blocked. It will be  
understood that in this situation, corresponding multiple apertures 8 in the secondary tube  
will also be provided.

Figures 4 and 5 illustrate alternative configurations of the distal end of a catheter 1 of the  
20 present invention again in axial cross-section. Features in these embodiments that  
correspond with those of figures 1 and 2 are numbered accordingly. The key difference  
between this embodiment and the embodiment of figures 1 and 2 is that the secondary  
tube 7 is not provided with an end cap 9. It can be seen that if the drainage tube 2 and  
secondary tube 7 are arranged in such a way that the secondary tube 7 can only be moved  
25 from its first position (illustrated in figure 4) to a second position (illustrated in figure 5)  
by moving the secondary tube 7 towards the distal end 4 of the catheter, then such a cap  
on the secondary tube becomes unnecessary, as the wall of the secondary tube will always  
provide an adequate seal for the drainage opening 3.

30 Figure 6 illustrates an alternative configuration of a cross-section of a catheter of the  
present invention taken at a position equivalent to A-A of Figure 1 and in which two  
drainage openings 3 are provided, together with two apertures 8 in the wall of a secondary

tube 7. Again, an instillation lumen 10 is provided, moulded into the wall of the drainage tube 2. In this embodiment, the instillation lumen defines a protuberance 13' in the inner wall of the drainage tube 2 that matches a longitudinal groove 14 along the outside wall of the secondary tube 7. These correspondingly-shaped profiles again provide a resistance  
5 against relative rotational movement between the drainage tube and the secondary tube, ensuring axial alignment of the apertures 8 with the drainage openings 3.

Figure 7 illustrates an alternative cross-section, again at a position corresponding to section A-A of Figure 1 in which the sliding movement of the secondary tube 7 relative to  
10 the drainage tube 2 is a relative rotational movement such that the drainage opening 3 may be aligned or, as illustrated, set out of alignment with the aperture 8 in the wall of the secondary tube 7.

Figure 8 illustrates a preferred variant of the feature illustrated in Figure 7, wherein a  
15 corresponding indent 15 and detent 16 are provided on the outside surface of the secondary tube 7 and the internal wall of the drainage tube 2 to allow rotational movement between the secondary tube 7 and the drainage tube 2, but to resist relative axial movement there between. Again, such a configuration allows the drainage outlet 3 and aperture 7 to be reliably positioned either in or out of alignment.

20

It will be appreciated that such a detent and indent mechanism could be arranged to provide a combination of rotational and axial movement by, for example, providing a helically disposed indent 15 that co-operates with a protruding detent 16.

25 Figure 9 and Figure 10 illustrate respectively the distal and proximal ends of a catheter of the present invention. The intervening length of catheter is not illustrated, for clarity, but would typically have a length of between for example 30cm to 1m. Features common to those illustrated in earlier embodiments are correspondingly numbered. At the distal end of the catheter 1 illustrated in Figure 9, the end of the secondary tube 7 is illustrated as  
30 being sealed with a plug 9, but could be equally open, as illustrated in the embodiments of Figures 3 and 4 due to the arrangement at the proximal end, to be described.

Figure 10 illustrates the proximal end of the catheter 1 showing the exit of the instillation lumen 10 to an instillation port 17 adjacent the proximal end of the catheter. In this illustration, the port 17 is shown merely as the end of a tube, but could preferably and conveniently be provided with an appropriate connector such as a Luer connector, or in particularly preferred embodiments a self-sealing septum and/or a one-way valve (not illustrated).

Figure 10 illustrates that in this embodiment the secondary tube 7 is connected to the drainage tube 2 by means of a ratchet mechanism, generally indicated by 18. The ratchet mechanism 18 has co-operating barbs 19 attached to elongate members 20 and connected to the secondary tube 7 via a pressure plate 21 connected to the outside of the secondary tube 7. The drainage tube 2 is connected to the receiving portion 22 of the ratchet mechanism 18. In use, the pressure plate 21 of the mechanism can be pushed toward the distal end of the catheter thereby moving the secondary tube 7 slidably within the drainage tube 2 and moving the tubes from the configuration shown in Figure 9 to that illustrated in Figure 5, thereby closing the flow path between the distal and proximal ends of the catheter through the lumen of the secondary tube 7. The ratchet mechanism 18 prevents the catheter being returned to its flow configuration, thereby preventing re-use of the device and hence preventing cross-infection that might result from re-use of the device.

Figure 11 illustrates in axial cross-sectional view, the distal end of a further embodiment of a catheter of the present invention. Again, features corresponding to those illustrated in other figures are numbered accordingly. In this embodiment, the catheter is further provided with a balloon 23 (in a first position) and 23' (in an inflated position) adjacent an external wall of the drainage tube 2 near the distal end 4 of the catheter but proximal of the drainage opening 3 and preferably the instillation opening 11. The interior of the balloon 23 (in the first position) is connected through a balloon control channel 24 to a balloon control port at the proximal end of the catheter (not illustrated) allowing the balloon to be inflated from the first position 23 to the inflated position 23' to anchor the catheter within the body cavity, for example at the neck of the urinary bladder. The

balloon may subsequently be deflated to allow the catheter to be removed once drainage and/or instillation of medicament have been carried out.

Figures 12 and 13 illustrate the distal end of an alternative embodiment of a catheter of the present invention, generally indicated by 1. In this embodiment, there is provided a drainage tube 2 again having a drainage opening 3 in its side wall. The drainage tube 2 is again sealed at its distal end 4 by means of a cap 5. In this embodiment, the closure member is in the form of a plug 25 located within the lumen of the drainage tube 2 and so shaped and sized as to provide a slidable but generally fluid-tight seal between the outside surface of the plug 25 and the inner surface of the drainage tube 2. The plug 25 is connected to a filament 26 that extends to a proximal end of the catheter and exiting the drainage tube 2 either at its end or, more preferably, through a side wall of the drainage tube 2. In use, when it is required to seal the drainage outlet 3, tension may be applied to the filament 26 to bring the plug 25 across the face of the drainage outlet 3 (or even further down the drainage tube) thereby sealing the flow path. The use of a filament, such as a length of nylon thread, renders the closure mechanism effectively irreversible due to the fact that the filament 26 is capable of transmitting forces in tension, but not in compression.

In any embodiment described herein, it is particularly preferred that a fluid such as a light silicone grease be applied between the interior face of the drainage tube and the outer face of the closure member, either when the closure member is a plug 25 or a secondary tube 7. The use of such a fluid serves two purposes: firstly to lubricate the relative sliding movement of the closure member and the drainage tube and, secondly to provide a more water tight seal there between.

In use, the catheter would be initially configured such that there is an open passage between the drainage opening 3 and the drainage outlet port 27. The catheter would be inserted into the body cavity, for example into the urinary bladder via the urethra, until fluid, such as urine, was seen to discharge from the drainage outlet port 27, which could be conveniently connected to a collection bag via, e.g. a catheter tip connector. Once fluid was seen to discharge from the port, this would indicate that the catheter was in a

suitable position within e.g. the bladder and, if one were provided, the location balloon 23 (in the first position) could be inflated 23' (into the inflated position) to secure the catheter in place. It is particularly preferred and envisaged, however, that no such balloon 23 is provided, but that the proximal end of the catheter could merely be taped in to position on an extremity of a patient, for  
5 example on the patient's leg to secure the catheter in place whilst the drainage and/or instillation of a drug were carried out. To aid such securement, a clip member may be provided into which the proximal end of the catheter can be secured and the clip fastened to the patient either with adhesive tape or some other releasable means.

10 Once sufficient fluid (e.g. urine) had been drained from the body cavity, the closure member may be actuated to close the flow path between the drainage opening and the drainage outlet. At this stage, if medicament is to be administered, it can be introduced into the body cavity by injection through the instillation port 17 at the proximal end of the catheter, to emerge at the instillation outlet 11 via the instillation lumen 10.

15

An example of a syringe and connector suitable for the administration of a medicament is illustrated in figures 14-16. A standard syringe 140 is utilised to retain and deliver a measured volume through the syringe outlet 141. The syringe outlet 141 is housed in, and connected to, the instillation port 17 (figure 10), by an adapted Luer slip connector. The adaptations described  
20 below prevent the connector from being used in conjunction with standard Luer fixtures.

The connector comprises two main elements. The first element is an adapter 142 having, at a first end, a tapered recess 143 to receive the syringe outlet 141. The outlet 141 and recess 143 connect via a push fit connection although additional bonding means can be included to provide  
25 a more secure connection. The second end of the adapter 142, shown in the end view figure 14a has recessed channels 144 and raised ribs 145, which achieve the prevention of the fitment of the adapter 142 to a standard Luer as mentioned above.

The adaptor 142 itself is seated in a one-way valve fitting 146 having at a first end a recess 147  
30 of shape complementary to that of the channels 144 and ribs 145 to provide a

secure fitting. The raised ribs 148 within the recess 147 prevent a standard Luer fitting from being inserted. The second end of the valve fitting 146 can be fitted to the instillation port 17. The one-way valve fitting 146 includes a spring 149 or other resilient means known in the art to bias the valve 146 to the closed position when no pressure is exerted on the fluid in the syringe 140. The assembled syringe and connector, including the adapter 142 and valve fitting 146 is shown in Figure 16.

Once administration is complete, the locational balloon 23 (if present) may be deflated, and the catheter withdrawn from the body cavity for disposal.

10

**CLAIMS**

1. An adapter for connecting a syringe to a catheter, said adapter comprising:
  - (a) at a first end, a tapered recess to receive an outlet from a syringe; and
  - (b) at a second end, a male connector having recessed channels and raised ribs disposed on a surface of said male connector.
  
2. A one-way valve fitting comprising a recess having a shape complementary to the channels and ribs of an adapter according to Claim 1.
  
3. A valve fitting according to Claim 2 fitted to an instillation port of a catheter.
  
4. A connector comprising an adapter according to Claim 1 and a one-way valve fitting according to either Claim 2 or Claim 3.
  
5. An adapter, valve fitting or connector according to any one of Claims 1 to 4, wherein said catheter is a urinary catheter.

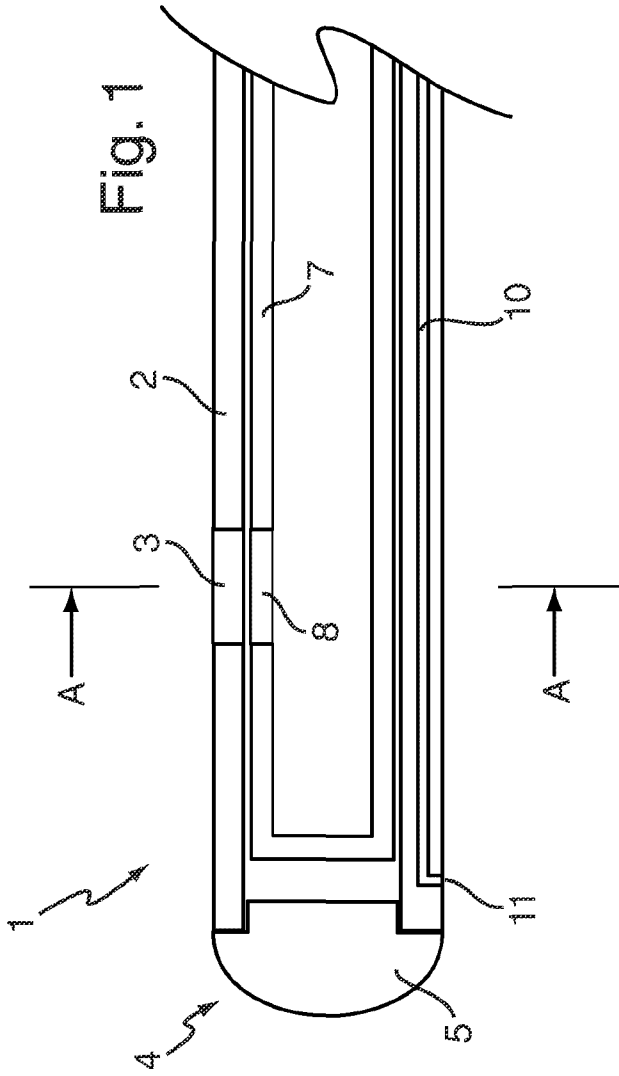

Fig. 1

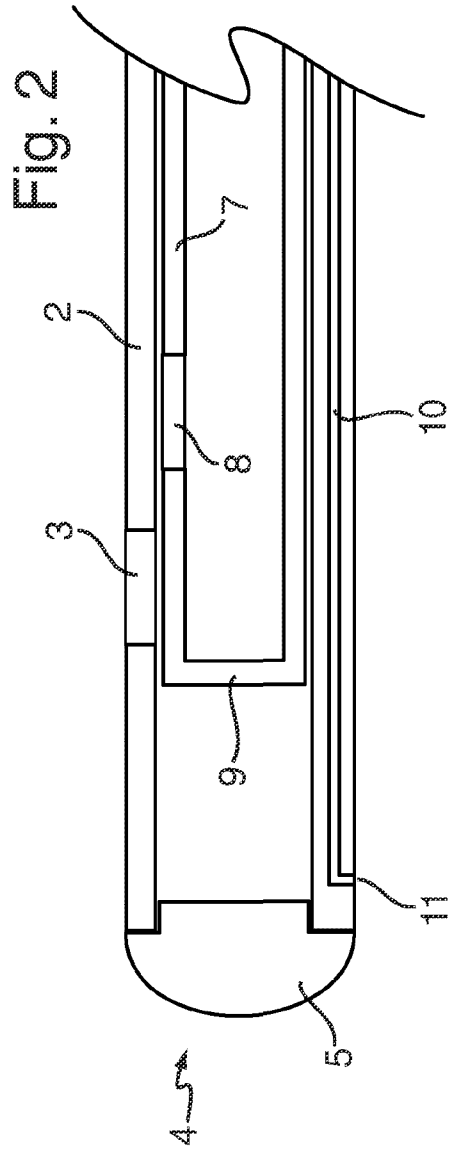

Fig. 2

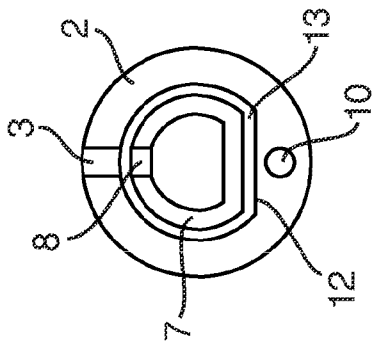

Fig. 3

Fig. 4

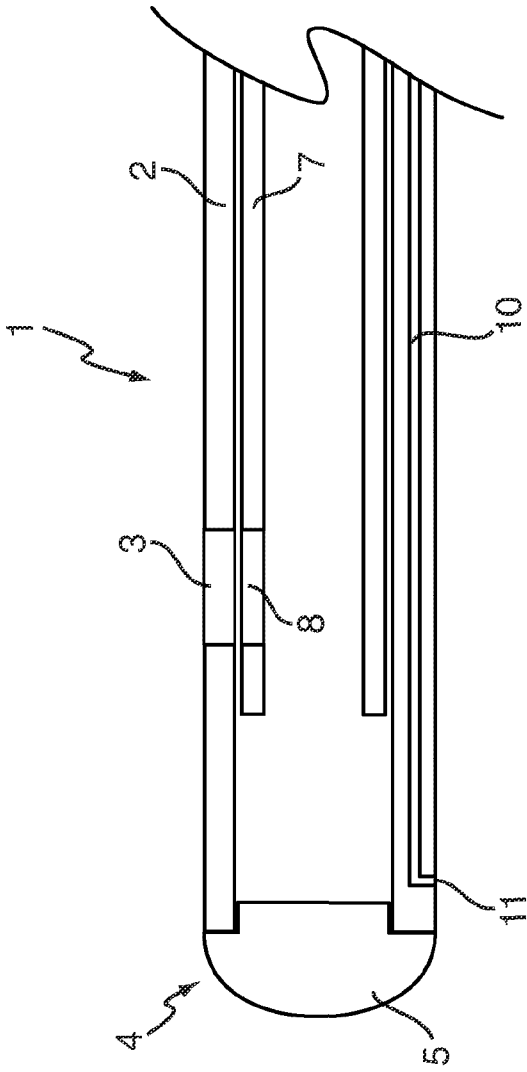

Fig. 5

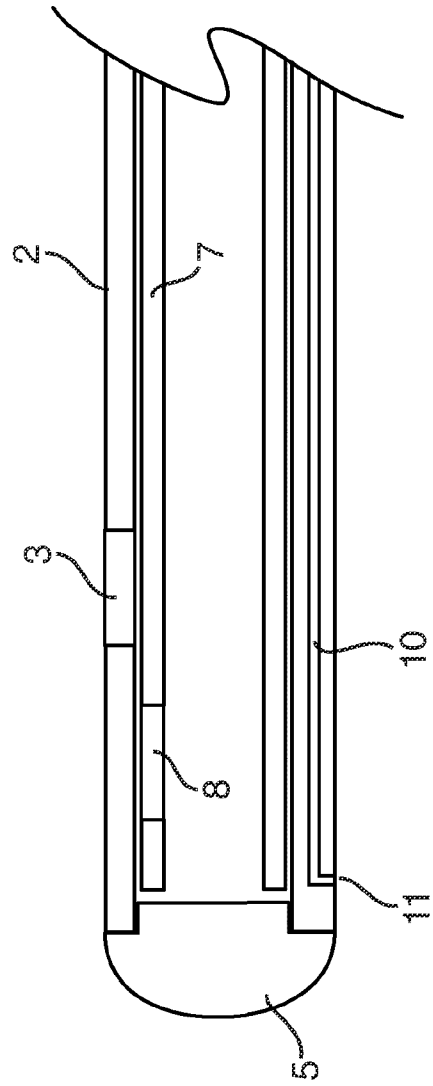

Fig. 6

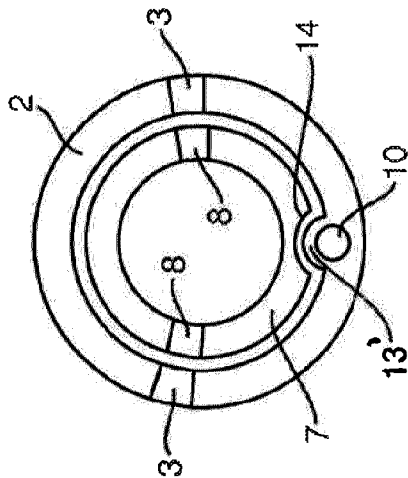

Fig. 7

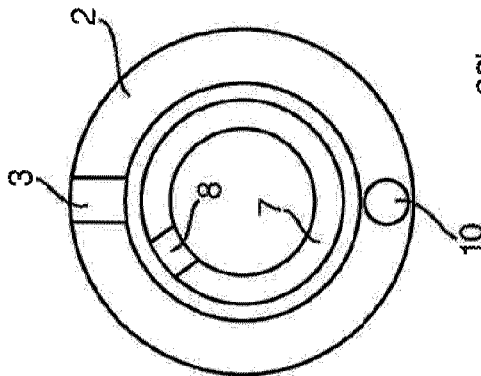

Fig. 8

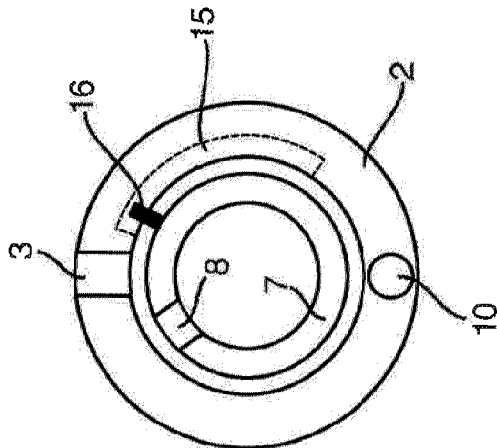
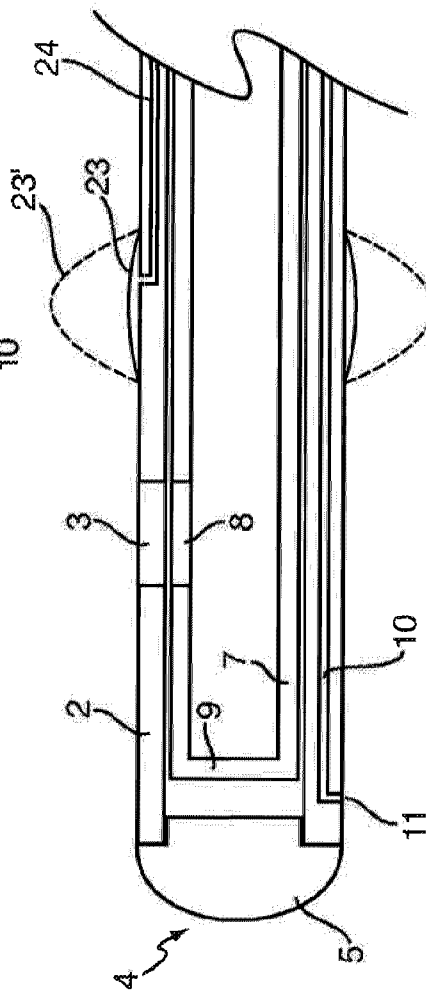
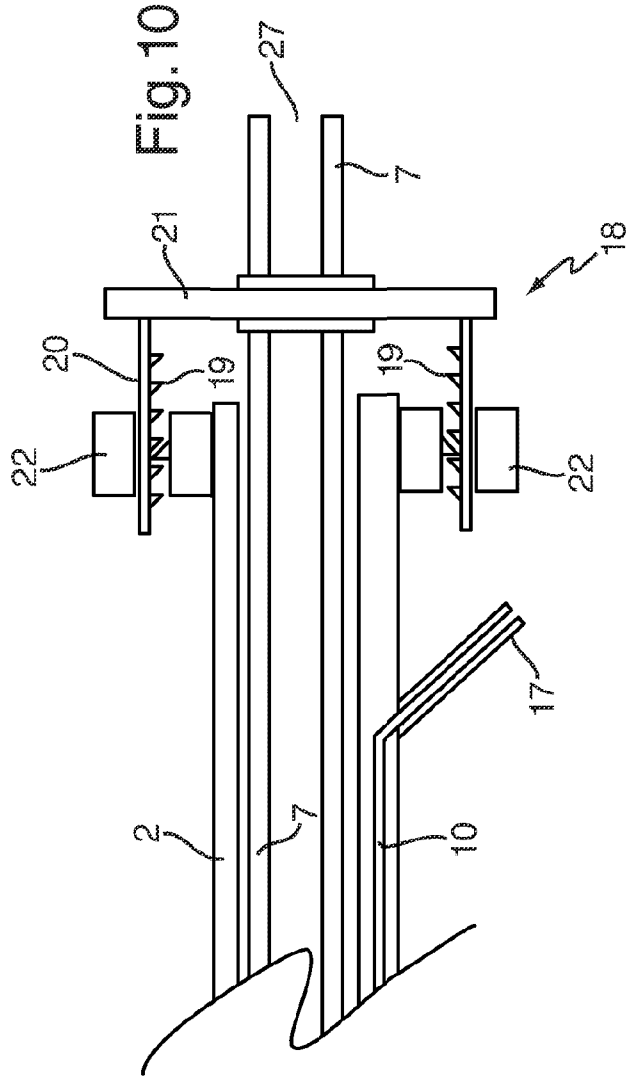
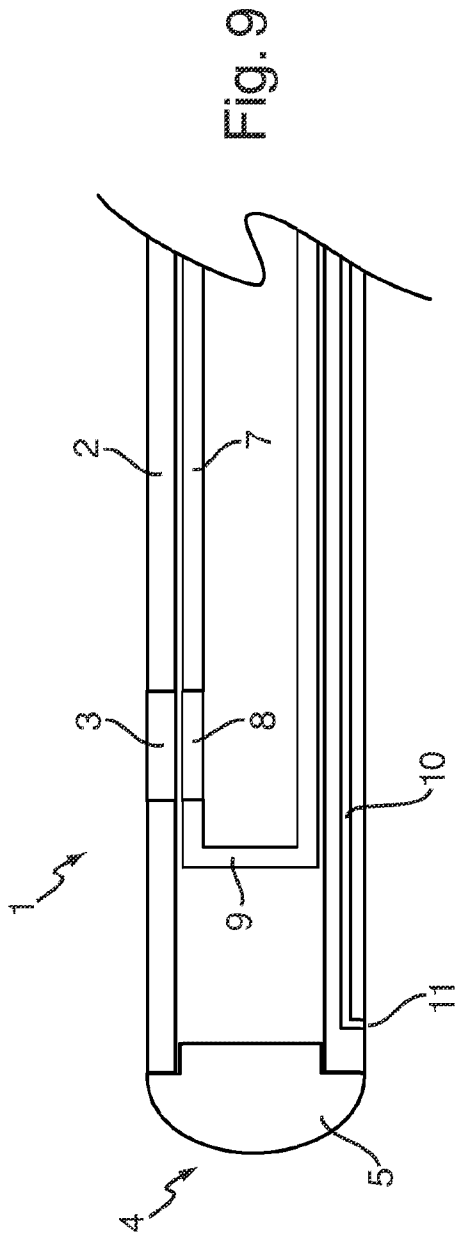

Fig. 11





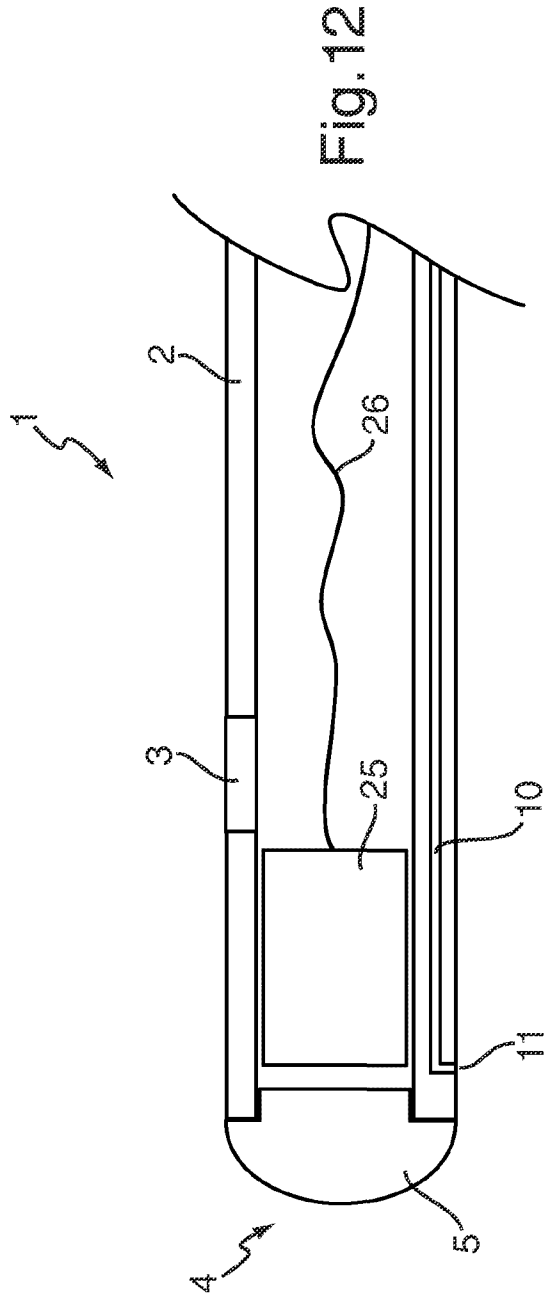

Fig. 12

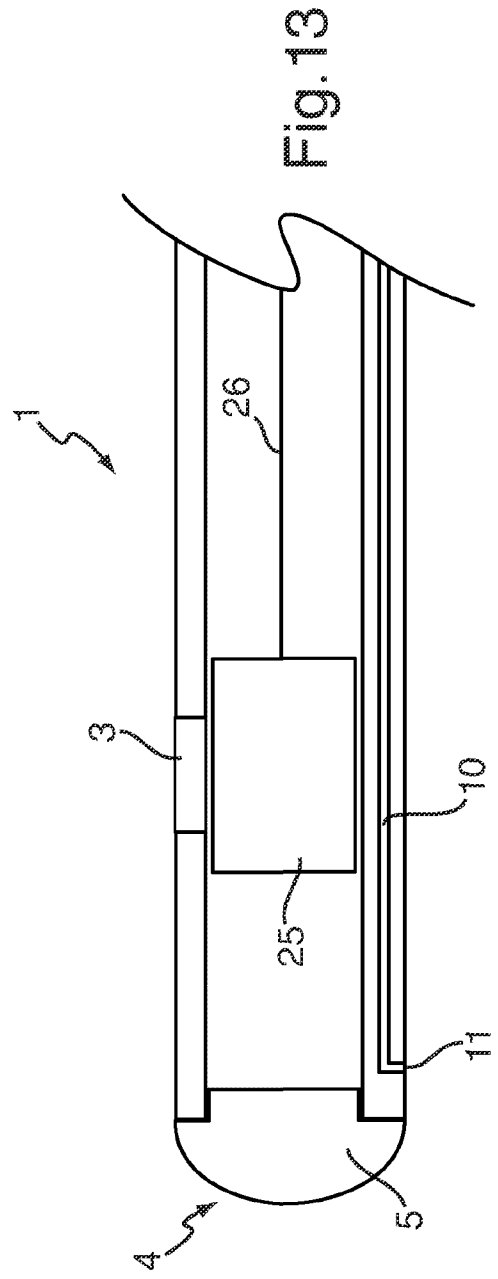

Fig. 13

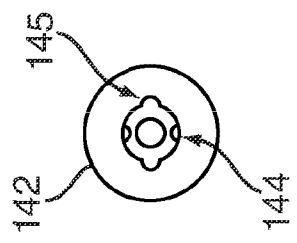

Fig. 14a

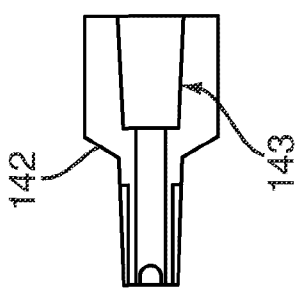

Fig. 14b

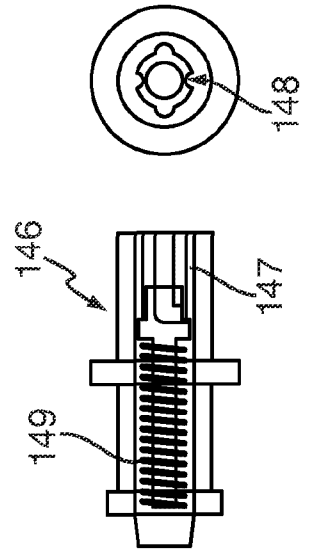

Fig. 15a

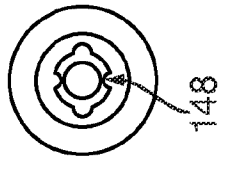

Fig. 15b

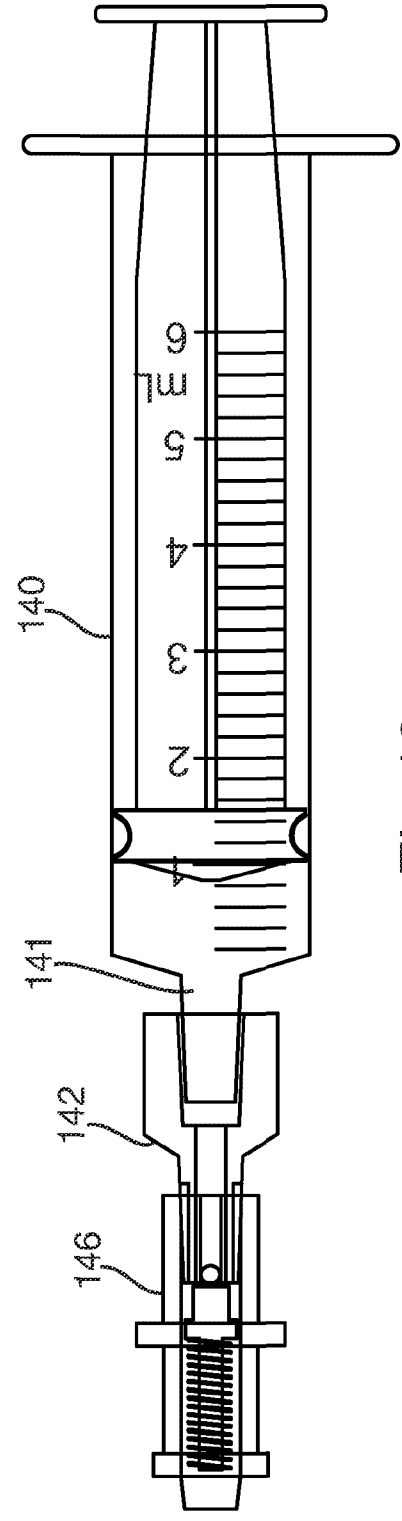

Fig. 16

