

(19) World Intellectual Property Organization
International Bureau



(43) International Publication Date
23 April 2009 (23.04.2009)

PCT

(10) International Publication Number
WO 2009/052432 A2

- (51) International Patent Classification:
A61B 17/12 (2006.01)
- (21) International Application Number:
PCT/US2008/080374
- (22) International Filing Date: 17 October 2008 (17.10.2008)
- (25) Filing Language: English
- (26) Publication Language: English
- (30) Priority Data:
60/981,451 19 October 2007 (19.10.2007) US
60/047,058 22 April 2008 (22.04.2008) US
- (71) Applicant (for all designated States except US): **CO-HEREX MEDICAL, INC.** [US/US]; 3598 West 1820 South, Salt Lake City, UT 84104 (US).
- (72) Inventors; and
- (75) Inventors/Applicants (for US only): **MILES, Scott, D.** [US/US]; 11732 S. Brisbane Drive, Sandy, UT 84094 (US). **LINDER, Richard, J.** [US/US]; 7810 Chatsworth Court, Sandy, UT 84093 (US). **DAVIS, Clark, C.** [US/US]; 6326 Crestmount Drive, Holladay, UT 84121 (US). **WHISENANT, Brian, K.** [US/US]; 1441 Perry Avenue, Salt Lake City, UT 84103 (US). **EDMISTON, Daryl, R.** [US/US]; 754 West Marsh Cove, Draper, UT 84020 (US).

- FOX, Dewayne, C.** [US/US]; 9532 South 4030 West, South Jordan, UT 84095 (US).
- (74) Agent: **JENSEN, Bradley, B.**; Holland & Hart, 60 E. South Temple, Suite 2000, Salt Lake City, UT 84111 (US).
- (81) Designated States (unless otherwise indicated, for every kind of national protection available): AE, AG, AL, AM, AO, AT, AU, AZ, BA, BB, BG, BH, BR, BW, BY, BZ, CA, CH, CN, CO, CR, CU, CZ, DE, DK, DM, DO, DZ, EC, EE, EG, ES, FI, GB, GD, GE, GH, GM, GT, HN, HR, HU, ID, IL, IN, IS, JP, KE, KG, KM, KN, KP, KR, KZ, LA, LC, LK, LR, LS, LT, LU, LY, MA, MD, ME, MG, MK, MN, MW, MX, MY, MZ, NA, NG, NI, NO, NZ, OM, PG, PH, PL, PT, RO, RS, RU, SC, SD, SE, SG, SK, SL, SM, ST, SV, SY, TJ, TM, TN, TR, TT, TZ, UA, UG, US, UZ, VC, VN, ZA, ZM, ZW.
- (84) Designated States (unless otherwise indicated, for every kind of regional protection available): ARIPO (BW, GH, GM, KE, LS, MW, MZ, NA, SD, SL, SZ, TZ, UG, ZM, ZW), Eurasian (AM, AZ, BY, KG, KZ, MD, RU, TJ, TM), European (AT, BE, BG, CH, CY, CZ, DE, DK, EE, ES, FI, FR, GB, GR, HR, HU, IE, IS, IT, LT, LU, LV, MC, MT, NL, NO, PL, PT, RO, SE, SI, SK, TR), OAPI (BF, BJ, CF, CG, CI, CM, GA, GN, GQ, GW, ML, MR, NE, SN, TD, TG).

Published:
— without international search report and to be republished upon receipt of that report

(54) Title: MEDICAL DEVICE FOR MODIFICATION OF LEFT ATRIAL APPENDANGE AND RELATED SYSTEMS AND METHODS

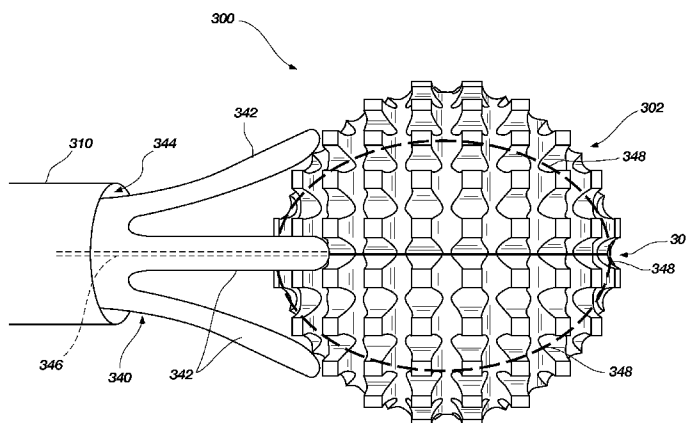

FIG. 18B

(57) Abstract: Several embodiments are set forth of devices, systems and methods for modifying an atrial appendage such as a left atrial appendage (LAA). In one embodiment, a device includes a body that is collapsible and self-expanding. The body includes a textured surface with protruding portions and recessed portions. The body may be formed of a reticulated foam material and may exhibit a substantially spherical geometry or a truncated spherical geometry. The body may be substantially hollow. In one embodiment, portions of the textured surface may be metalized or have a coating placed thereon to enhance frictional engagement of the body with the atrial appendage wall. In another embodiment, a mesh bag is disposed within an LAA and one or more self-expanding bodies are disposed within the mesh bag. The mesh bag is then secured to retain the self-expanding bodies within the bag and the LAA.

WO 2009/052432 A2

-1-

**MEDICAL DEVICE FOR MODIFICATION OF LEFT ATRIAL APPENDAGE
AND RELATED SYSTEMS AND METHODS**

5

TECHNICAL FIELD

The present invention relates generally to the modification of a left atrial appendage and, more specifically, to devices, systems and methods for occluding or otherwise structurally altering such appendages.

10

BACKGROUND

The left atrial appendage is a feature of all human hearts. The upper chambers of the heart, the atria, have this appendage attached to each of them. The physiologic function of such appendages is not completely understood, but they do act as a filling reservoir during the normal pumping of the heart. The appendages typically protrude from the atria and cover an external portion of the atria. Atrial appendages differ substantially from one to another. For example, one atrial appendage may be configured as a tapered protrusion while another atrial appendage may be configured as a re-entrant, sock-like hole. The inner surface of an appendage is conventionally trabeculated with cords of muscular cardiac tissue traversing its surface.

20

The atrial appendages are inert while blood is being pumped through them during normal heart function. In other words, the appendages don't have a noticeable effect on blood pumped through them during normal heart function. However, in cases of atrial fibrillation, when the atria go into arrhythmia, blood may pool and thrombose inside of the appendages. Among other things, this can pose a stroke risk when it occurs in the left appendage since the thrombus may be pumped out of the heart and into the cranial circulation.

25

Historically, appendages have sometimes been modified surgically to reduce the risk imposed by atrial fibrillation. In recent years devices which may be delivered percutaneously into the left atrial appendage have been introduced. The basic function of these devices is to exclude the volume within the appendage with an implant which then allows blood within the appendage to safely thrombose and then to be gradually

30

-2-

incorporated into cardiac tissue. This can leave a smooth, endothelialized surface where the appendage used to be.

DISCLOSURE OF INVENTION

5 Embodiments of the present invention include percutaneously delivered implants or medical devices designed to exclude or modify the inner surface of the left atrial appendage to reduce the risk of stroke during atrial fibrillation. Embodiments of the present invention further include related methods and systems.

 In accordance with one embodiment of the present invention, a medical device for
10 modifying a left atrial appendage (LAA) is provided. The medical device includes a body formed of a self-expanding material. The body exhibits a textured surface including a plurality of protruding portions and a plurality of recesses. Each protruding portion is separated from an adjacent protruding portion by a recess of the plurality of recesses. In one embodiment, the body may exhibit a substantially spherical geometry. The body may
15 be formed from a material that comprises, for example, a reticulated foam.

 In accordance with another embodiment of the present invention, a medical device for modifying a left atrial appendage includes a mesh bag and at least one self-expanding body disposed within the mesh bag. The self-expanding body may include one or more foam bodies. The mesh bag may be formed of, for example, a material comprising at least
20 one nylon, polyester or silicone. The self-expanding body or bodies may be formed of, for example, at least one of a polymer foam, polyurethane, and polyvinyl acetate.

 In accordance with another embodiment of the present invention, a method of
modifying a left atrial appendage is provided. The method includes providing a body
formed of a self-expanding material, the body exhibiting a textured surface including a
25 plurality of protruding portions and a plurality of recesses, wherein each protruding
portion is separated from an adjacent protruding portion by a recess of the plurality of
recesses. The body is compressed within a delivery vehicle and the delivery vehicle is
positioned adjacent an opening of the LAA. The body is discharged from the delivery
vehicle into the LAA and expanded such that the body engages a side wall of the LAA
30 and substantially occludes an opening of the LAA.

 In accordance with yet another embodiment of the present invention, another method is provided for modifying a left atrial appendage. The method includes disposing

-3-

a mesh bag within the LAA and disposing at least one self-expanding body within an interior of the mesh bag. The mesh bag is securely closed to retain the at least one self-expanding body within the bag.

In another one embodiment, the medical device includes a first frame member, a second frame member, a spring member and a tissue in-growth member. The first and second frame members include a first and second flat configuration, respectively, and are non-coplanar with each other. The first frame member is configured to anchor within the left atrial appendage (LAA). The spring member is connected between the first and second frame members. The tissue in-growth member is attached to the second frame member and is configured to cover an opening of the LAA.

In a further embodiment, the medical device includes a frame member having a substantially flat configuration and includes distal anchor members for anchoring the frame member within the LAA. The medical device also includes a tissue in-growth member that is attached to the frame member and configured to cover an opening of the LAA.

In yet another embodiment, the medical device includes a frame member having an anchoring system that is configured to anchor the frame member at least partially within the LAA. The medical device also includes a tissue in-growth member that is attached to the frame member and is configured to prevent potential embolic material from escaping the LAA.

These and other aspects of the present invention will become more fully apparent from the following description and appended claims, or may be learned by the practice of the invention as set forth hereinafter.

BRIEF DESCRIPTION OF DRAWINGS

The foregoing and other advantages of the invention will become apparent upon reading the following detailed description and upon reference to the drawings in which:

FIGS. 1A and 1B are perspective and side views of a medical device according to one embodiment of the present invention;

FIG. 1C illustrates an example of an atrial appendage;

FIG. 1D shows the device of FIGS. 1A and 1B disposed in an atrial appendage;

-4-

FIGS. 2A, 2B and 2C are side, end and perspective views, respectively, of another medical device according to an embodiment of the present invention;

FIG. 3A illustrates a medical device according to another embodiment of the present invention;

5 FIG. 3B shows the medical device of FIG. 3A disposed in an atrial appendage according to an embodiment of the present invention;

FIG. 4 is an end view of a medical device according to an embodiment of the present invention;

10 FIG. 5 is a side view of a medical device disposed in an atrial appendage according to an embodiment of the present invention;

FIGS. 6A and 6B illustrate respective side and end views of a medical device according to another embodiment of the present invention;

FIG. 6C shows the medical device of FIGS. 6A and 6B disposed in an atrial appendage;

15 FIG. 7 shows another embodiment of a medical device disposed in an atrial appendage;

FIG. 8 shows another embodiment of a medical device disposed in an atrial appendage;

20 FIG. 9A is an end view of a medical device according to another embodiment of the present invention;

FIG. 9B shows the medical device of FIG. 9A disposed in an atrial appendage according to one embodiment of the present invention;

FIGS. 10A and 10B are end and cross-sectional views of a medical device according to an embodiment of the present invention;

25 FIG. 10C shows a variation of the embodiment shown in FIGS. 10A and 10B;

FIG. 10D shows the medical devices of FIGS 10A-10C disposed in an atrial appendage according to another embodiment of the present invention;

FIG. 11 is an end view of a medical device according to yet another embodiment of the present invention;

30 FIG. 12 shows a medical device according to another embodiment of the present invention disposed in an atrial appendage;

-5-

FIGS. 13A through 13F show variations of a medical device according to additional embodiments of the present invention;

FIG. 14 shows a medical device disposed in an atrial appendage according to yet another embodiment of the present invention;

5 FIG. 15 shows a medical device in the general form of a substantially spherical body according to one embodiment of the present invention;

FIGS. 16A-16C show the medical device of FIG. 15 being deployed into an atrial appendage according to an embodiment of the present invention;

FIG. 16D shows the medical device of FIG. 15 disposed in an atrial appendage;

10 FIGS 17A and 17B are side and end views of another medical device according to an embodiment of the present invention;

FIG. 18A shows a delivery mechanism or apparatus for deploying a medical device in accordance with an embodiment of the present invention;

15 FIG. 18B shows the delivery mechanism of FIG. 18A deploying the medical device of FIG. 15;

FIGS 19A and 19B are end views of a medical device while in a compressed, pre-delivery state and an expanded, post-delivery state according to an embodiment of the present invention; and

20 FIGS. 20A-20D show a medical device and a delivery system at various stages of deployment according to another embodiment of the present invention.

BEST MODE(S) FOR CARRYING OUT THE INVENTION

Referring to FIGS. 1A through 1D, a medical device 100 is shown that may be used to occlude or modify an opening or cavity such as a left atrial appendage (LAA) 102 (FIGS. 1C and 1D). The medical device 100 includes a frame 104 having a distal anchoring portion or anchor member 106, a spring or biasing member 108 and a proximal cover portion or cover member 110. It is noted that the use of terms such as “distal,” “proximal,” “upper,” and “lower” and other relative terms are used in particular reference to the drawings and such use is not to be construed as limiting with regard to absolute positions of various components described and discussed herein.

The anchor member 106 may be sized and configured to expand outward against a surface of a wall 112 of the LAA 102 so that upper and lower portions of the anchor

-6-

member 106 extend to a dimension that is larger than the LAA opening 114. The anchor member 106 can be formed of, for example, a shape memory alloy such as Nitinol. Use of such a material enables the anchor member 106 to be delivered in a collapsed state and then self-expand upon deployment in the LAA 102. In another embodiment, the anchor member 106 may be configured to be manually expanded upon delivery to and deployment in the LAA 102. In one embodiment, a spring or biasing member 115 may be positioned within the anchor member 106 so as to pull opposing distal and proximal sides of the anchor member 106 towards one another such the upper and lower portions of the anchor member 106 are placed in, and maintained in, an expanded or extended position.

5 A plurality of tines 116, which may include, for example, posts or barbs, may be disposed on the anchor member 106. The tines 116 may be located and configured to “grab” or otherwise engage the LAA wall 112. With such an arrangement, the anchor member 106 is configured to be positioned and anchored within the LAA 102 to prevent migration of the medical device 100 out of the LAA 102. In one embodiment, the anchor member 106 may be substantially flat and planar. The anchor member 106 may also include a tissue in-growth member 118 associated therewith, such as a polymer substrate, or any suitable known member for promoting tissue growth. According to one aspect of the present invention, the tissue in-growth member can be a porous polymer member, such as a polymer based foam or fabric. In one embodiment, fabric may be disposed over the frame of the anchor member 106. In another embodiment a foam member may be disposed on or within the frame of the anchor member 106.

The cover member 110 is connected to the anchor member 106 via the biasing member 108. The cover member 110 may include a frame 120 sized and configured to be larger than the opening 114 of the LAA 102. The frame 120 can be configured to support a tissue in-growth member 122, such as a polymer substrate, or any suitable tissue promoting or enhancing member. Such tissue in-growth member 122 can be a porous member, such as reticulated foam, fabric or Dacron®, configured to hold blood cells and to promote and induce tissue growth. With the cover member 110 being coupled with the anchor member 106 via the biasing member 108, the cover member 110 can be configured to be biased against the left atrial wall 124 over the opening 114 of the LAA 102 via the biasing member 108 after the anchor member 106 is appropriately positioned and anchored within the LAA 102.

-7-

When deployed within the LAA 102, the medical device 100 covers or occludes the opening 114 of the LAA to seal off the LAA 102 from the left atria. Thus, if any embolic material exists within the LAA 102, the medical device 100 prevents such from leaving the LAA 102 and entering back into the left atria. Additionally, the medical device prevents further entry of blood into the LAA 102 and, thus, further preventing production of embolic material within the LAA.

Referring now to FIGS. 2A through 2C, another medical device 130 is shown which is configured to be anchored within and occlude a cavity such as an LAA 102 (FIG. 1C). The medical device 130 may include a multi-planar structure 132 sized and configured to be anchored within the LAA 102. The multi-planar structure 132 may be formed of individual planar structures 132A and 132B arranged to extend in separate planes. Each planar structure 132A and 132B can include a central frame portion 134 having a multi-cellular structure with distal anchors 136 extending therefrom, the anchors 136 being sized, located and configured to engage the LAA wall 112 and anchor the medical device 130 therein. Further, each planar structure 132A and 132B may be self-expanding to facilitate the deployment of the distal anchors 136 and engagement with the LAA wall 112. Such anchoring can be further facilitated with tines 138 extending from the distal anchors 136 to grab or more affirmatively engage the tissue wall 112 of the LAA 102. The multi-planar structure 132 provides anchors in multiple planes to ensure the medical device 130 is secured within the LAA 102. In addition, each planar structure 132A and 132B may include proximal anchors 140 extending from the central frame portion 134. The proximal anchors 140 may be configured to extend around the outer rim of the opening 114 of the LAA 102 so as to be seated and biased against the left atrial wall 124. The proximal anchors 140 may be coupled to a polymer substrate 142 or may be covered by a suitable tissue in-growth member that may cover the opening 114 of the LAA 102 such as has been previously described above.

FIGS. 3A and 3B illustrate another embodiment of a medical device 150 configured to engage and be anchored within an LAA 102 (see also FIG. 1C) and occlude the opening 114 of the LAA 102. The medical device 150 includes a planar structure 152 having distal anchors 154 extending from a multi-cellular central portion 156 that is attached to a cover member 158. The cover member 158 may include, for example, a polymer substrate. The medical device 150 is similar to the embodiment described with

-8-

respect to FIGS. 2A-2C, except the medical device 150 only employs a single planar structure 152. The planar structure 152 of the medical device 150 (or the planar structures 132A and 132B of the previously described medical device 130) may be formed, for example, in a manner similar to the planar structures described in U.S. Patent Application
5 No. 11/836,123 filed on August 8, 2007, entitled METHODS, SYSTEMS, AND DEVICES FOR REDUCING THE SIZE OF AN INTERNAL TISSUE OPENING and assigned to the assignee hereof, the disclosure of which is incorporated by reference herein in its entirety.

The cover member 158 may be sized and configured to be biased or to sit against
10 the LAA opening 114. Further, as with other embodiments, the cover member 158 is not limited to a polymer substrate, but may include any suitable tissue in-growth member known in the art. Additionally, with reference to FIG 3B, which shows a rotated view of the medical device 150 as compared to that of FIG. 3A, the cover member 158 may be positioned within the LAA 102 so as to fold distally (as shown in dashed lines) and
15 against the LAA wall 112. In another embodiment multiple cover members 158 may be used with one folded within the LAA 102 and another covering the opening 114.

FIG. 4 shows an end view of another medical device 160 according to an embodiment of the present invention. The medical device is similar to that which is described with respect to FIGS. 2A through 2C having a plurality of planar structures
20 162A, 162B and 162C coupled with a cover member 164. The cover member 164 exhibits a different size and shape than that of the medical device 130 of FIGS. 2A-2C. Additionally, to compliment the elongated geometry of the cover member 164, one of the planar structures 162A is also elongated and multiple planar structures 162B and 162C are associated with the elongated planar structure 162A to extend out-of-plane (e.g.
25 orthogonally) with respect to the elongated planar structure 162A. With the anchoring system having multiple flat or planar structures, it can provide additional support and anchoring to the LAA wall 112 to prevent migration of the device. Additionally, this configuration enables closure of an LAA 102 (FIG. 1C) that, for example, is relatively large or exhibits an elongated opening.

30 Referring now to FIG. 5, another medical device 170 is shown. The medical device 170 is generally similar to that which is described with respect to FIGS. 3A and 3B and includes a planar structure 172 coupled with a cover member 174. However, rather

than using anchors that extend distally within the LAA 102 (as described with respect to FIGS. 3A and 3B), anchors 176 are coupled to the central portion 178 of the planar structure 172 so as to extend back towards the cover member 174 and into the flesh of the LAA wall 112.

5 Referring now to FIGS. 6A through 6C, another embodiment of medical device 190 is shown. In this embodiment, the medical device 190 includes a multi-arm anchor 192 coupled with a cover member 196. As with the other embodiments described herein, the cover member 196 may include a suitable tissue in-growth material to promote or enhance growth of tissue into and over the cover member 196.

10 The anchor 192 includes a plurality of arms 192A-192D joined at a central hub 194. Along the length of each arm 192A-192D, tines 96 may extend therefrom and be oriented so that the medical device 190 is substantially prevented from migrating from the LAA 102 once it is disposed therein. The arms 192A-192D may each extend from the central hub 194 and self-expand when delivered to the LAA 102 in a manner such that
15 each arm 192A-192D independently expands and biases against the LAA wall 112 to secure the medical device 112 within the LAA 112. A biasing member 199 may be coupled between the anchor 192 and the cover member 196 so as to bias the cover member 196 against the atrial wall 124 and more effectively cover or occlude the LAA opening 114.

20 FIG. 7 illustrates an embodiment of a medical device 200 that includes an anchor 202 similar to that described with respect to FIGS. 6A through 6C. The medical device 200 of this embodiment includes a foam or fabric 204 disposed over the proximal ends of the anchor 202. In one embodiment, the foam or fabric 204 may be configured to substantially fill or cover the envelope defined by the geometry of the expanded anchor
25 202. Similar to previously described embodiments, tines 206 may be associated with the anchor 202 to engage the LAA wall 112.

 FIG. 8 illustrates another embodiment of a medical device 210 having an anchor 212 coupled to a cover member 214 via a biasing member 216. The anchor 212 may include a distal end portion 218 configured to be connected to the LAA wall 114 such as
30 by tines or barbs 220 or by stitching. Similar to previous embodiments, cover member 214 can, thereby, be biased against the left atrial wall 124 so as to cover the LAA opening

-10-

114. Again, the cover member 214 may include an in-growth material, such as a polymer substrate.

Referring now to FIGS. 9A and 9B, a medical device 230 is shown that includes a self-expanding frame structure 232 having a plurality of spokes 234 joined at a common
5 hub 236. The self-expanding feature of the frame structure 232 can assist or substantially ensure that the medical device 230 is secured within the LAA 102 by exerting an appropriate radial force against the LAA walls 114. An in-growth material 238 (only partially shown for purposes of clarity), which may include a polymer substrate such as
10 foam or fabric, may extend around the frame structure 232 to promote tissue growth and, thereby, close the opening 114 of the LAA 102. As shown in FIG. 9B, the frame structure 232 may act to close the LAA 102 on its own accord, or it may be used in conjunction with a separate cover member 240 (shown in dashed lines) and act as an anchoring device (or as a redundant closure device) associated with such a cover member 240.

FIGS. 10A through 10D illustrate a medical device 250 having a self-expanding
15 frame structure 252 that expands in a radial direction so as to engage the walls 114 of an LAA 102. The frame structure 252 can be substantially planar or flat and can be a continuous or unitary structure. The frame structure 252 may exhibit any of a variety of geometric configurations when it is in an expanded state. For example, the frame structure may exhibit a circular geometry as indicated in FIG. 10A, or it may exhibit a
20 substantially oval geometry as indicated in FIG. 10C. The frame structure 252 may exhibit any other suitable peripheral shape that enables the frame structure 252 to expand and cause associated tines 254, extending from the periphery of the frame structure 252, to grab or engage the LAA wall 114 as indicated in FIG. 10D. A polymer substrate 256 (or any suitable tissue growth promoting member) may be attached to the frame structure 252.
25 For example, the material of such a substrate 256 may wrap around and encase the frame structure 252, it may extend between opposing peripheral sides of the frame structure 252, or it may do both. In another embodiment, the medical device may be devoid of tines such that it relies solely on a radially expanding force of the frame structure 252 to maintain medical device within the LAA 102.

30 FIG. 11 illustrates another embodiment of a medical device 260 to be disposed and anchored within an LAA 102 (FIG. 1C). The medical 260 may include a self-expanding frame member 262, that may exhibit a flat configuration with a rounded or arcuate

-11-

periphery when in an expanded state, with tines 264 configured to anchor within the LAA wall 114. The tines 264 are curved such that they do not extend directly radially outward from the frame member 262. Such a configuration enables the medical device 260 to engage the LAA wall 114 by rotating the expanded medical device 260 within the LAA 102 to effectively lodge the tines within the LAA wall 114. One advantage of rotating the device to effect anchoring thereof is that the device is anchored without having to pull the device in the proximal direction to effect such anchoring. The medical device 260 may further include a polymer substrate 266 or other in-growth material to act as a cover member and effect tissue growth when disposed within the LAA 102. In another embodiment, the frame member 262 could act as an anchor member for a separate cover member such as has been described hereinabove.

FIG. 12 illustrates another embodiment of a medical device 270. The medical device includes a frame member 272 having multiple elongate members 272A and 272B that are configured to bypass or cross each other at an intermediate portion 274 of each elongate member 272A and 272B. The frame member 272 can be self-expanding and, when in the expanded configuration, each elongate members 272A and 272B may expand to a curvilinear configuration such that the multiple elongate members cooperate to collectively exhibit a geometry in the shape of an hour glass. From a common juncture (i.e., the intermediate portion 274 of the multiple elongate members 272A and 272B), there are distally extending portions 276 and proximally extending portions 278 of the elongate members 272A and 272B that form the hour glass configuration. The distally extending portions 276 can act as distal anchor portions. The proximally extending portions 278 can act as proximal anchor portions and a support structure for a proximal cover portion (not shown in FIG. 12). As in the previous embodiments, the frame member 272 can include an in-growth member, such as a polymer substrate, to act as a cover and/or to promote or induce tissue growth.

Referring now to FIGS. 13A through 13F (and continued reference to the LAA shown in FIG. 1C), various embodiments of another medical device 280 are shown. As seen in FIGS. 13A through 13C, the medical device 280 may include a frame member 282 formed to exhibit the shape of a helical coil. FIG. 13A shows an end view of the medical device 280 while FIG. 13B shows a side view of the medical device 13B.

-12-

The frame member 282 may be formed from, for example, a shape member alloy such as Nitinol, such that the frame member 282 may be disposed within a catheter 284 or other delivery vehicle in an undeployed (e.g., a lengthened, uncoiled) state. When deployed from the catheter 284 or other delivery vehicle, the frame member 282 expands to its coiled state such as shown FIGS. 13A-13C. When in the expanded, coiled state, the frame member 282 may be sized to engage the LAA wall 112 and apply a desired force to anchor or lodge the medical device 280 within the LAA 102. While not expressly shown in FIGS. 12A-13C, the frame member 282 may be coupled to a cover member, such as been described with respect to numerous other embodiments herein, to cover or occlude the LAA opening 114.

In another embodiment, and as shown in FIGS. 13D and 13F, the frame member 282 may be coated or encased with a foam or other tissue in-growth material 286. Depending on the thickness of the coating of such material on the frame member 282, and depending on the radius and spacing of the coils of the frame member 282, such a configuration may act as an occluding member due to the collection or accumulation of the in-growth material on and within the coils of the frame member 282. In yet other embodiments, the frame member need not be in the configuration of a helical coil. Rather, for example, it may for a substantially circular geometry or oval geometry such as are exhibited by the embodiments described with respect to FIGS. 10A-10D. In other embodiments, the frame member may be a coil which is substantially flat or lies within a single plane. Other geometric configurations are also contemplated.

FIG. 14 illustrates another embodiment of a medical device 290 configured to be disposed within and fill or occlude the LAA 102 (FIG. 1C). The medical device 290 includes a foam body 292 that is sized and configured such that, when deployed within the LAA 102, the LAA 102 expands to a size that is larger than its natural state. After the foam body 292 is disposed within the LAA 102, a stiffener material may then be released from a catheter 294 and injected throughout the foam body 292 to cause the foam body 292 to become substantially rigid or stiff. The foam body may be anchored within the LAA by virtue of the forces applied to the LAA wall 112, by its rigidity, or through a combination of both properties. Although not shown, the medical device 280 may also include a cover member to further prevent potential embolic material from migrating from the LAA 102.

-13-

Referring now to FIG. 15, another medical device 300 is shown. The medical device 300 includes a body 302 which may exhibit a substantially spherical geometry and have a textured surface. The textured surface may include a plurality of protruding portions 304 (which may exhibit any of a variety of shapes) separated by recessed portions 306. In one embodiment of the present invention, the body 302 includes a self-expanding resilient porous material that, when fully expanded, enlarges to a predetermined expanded shape. The body 302 may be formed, for example, of a foam material. For example, the body may be formed a polyurethane material, a polymer foam, or a polyvinyl acetate material, silicon material, or polyester material. Other polymeric materials that can be utilized are self-expanding felts. In the case of foam, such foam may be a reticulated foam, typically undergoing a heating process to open the pores within the foam as known in the art. The foam may also be a non-reticulated foam.

It is also contemplated that the body 302 of the medical device 300, in another embodiment, can be formed without the plurality of protruding portions and recessed portions described above. In other words, the surface of the body 302 can be left relatively smooth or untextured in its substantially natural state of, for example, the foam material.

In one embodiment, the body may be a "solid" geometry meaning that the foam or other material extends through the body 302. In another embodiment, the body 302 may be substantially hollowed out or hollowed at one or more selected portions within the body 302. When hollowed out, the body 302 would be more compact when collapsed and carried by a catheter or other delivery vehicle. While the body 302 may exhibit other geometries (e.g., cylindrical, ovoid, elongated), the use of a spherical or substantially spherical geometry (referring to the overall shape and disregarding the textured surface) enables deployment of the medical device 300 within an LAA 102 (FIG. 1C) with less sensitivity to the approach angle of the catheter or other delivery vehicle with respect to the LAA 102. Thus, use of a substantially spherical configuration provides greater ease of use in installing or deploying the medical device 300. Other configurations may also be employed, such as conical, cylindrical or combinations thereof, which also may include hollowed out portions.

In another embodiment, the foam or other material can include variations within portions of the body 302 such that various portions of the body may compact smaller than

-14-

other portions of the body. Such can be employed, for example, by manipulating the number of pours per square inch in the material forming the body 302 so that the body exhibits a graded porosity. For example, for a spherical configuration, the central region of the foam body may include a different number of pours than the outer regions of the foam body so as to manipulate the compactive and expansive characteristics of the foam body. Additionally, or alternatively, one-half of the sphere may exhibit one level of porosity while the other half exhibits a different level of porosity. Similarly, along the length of any other shaped configuration, such as a conical or cylindrical configuration the level of porosity may change. Additionally, such changes in porosity may be gradual, or may be relatively abrupt.

Referring to FIGS. 16A through 16D, deployment of the medical device 300 is shown. As seen in FIG. 16A, a catheter 310 or other delivery vehicle is guided to the LAA 102 using techniques that will be appreciated and understood by those of ordinary skill in the art. The catheter 310 enters the LAA 102 and begins to deploy the body 302 from within the catheter 310. As seen in FIGS. 16A-16C, as the medical device is deployed from the catheter 310, it expands (the body 302 being formed of a self-expanding material) so as to fill or substantially fill the LAA 102. In other embodiments, the body 302 may simply fill enough of the LAA 102 to anchor itself within the LAA 102 and to block or occlude the LAA opening 114. FIG. 16D shows the medical device disposed within the LAA 102.

The textured surface of the body 302 may be tailored depending on a variety of factors. For example, the protruding portions 304 may be configured to effect increased engagement with the LAA wall 114 (FIG. 1C) and help anchor the medical device 300 within the LAA 102. Additionally, the depth, width and frequency of the recessed portions 306 of the textured surface may be configured to cooperatively engage with trabeculations within the LAA 102. Further, the textured surface may have portions that are selectively configured for a specific function as will be discussed in further detail below.

Referring briefly to FIGS. 17A and 17B, another embodiment of a medical device 320 is shown. The medical device 320 is similar to that which is described with respect to FIG. 15 and includes a body 322 have a textured surface with protruding portions 324 separated by recessed portions 326. The body 322, while exhibiting a generally spherical

-15-

geometry, is truncated on one side to define an opening 328 that exposes the hollow interior 330 of the body 322. The opening 326 does not impair the functionality of the medical device to occlude the LAA opening 114 (FIG. 1C) so long as the opening 328 is positioned such that it is fully within the LAA 102 and not directly exposed to the LAA opening. In other words, the opening should be positioned so as to not create a communication path between the atria and the LAA 102. Such a configuration further reduces the overall mass of the body 302 making it smaller when compacted within a catheter or other delivery mechanism. Additionally, such a configuration may be easier to manufacture when using certain manufacturing processes as will be appreciated by those of ordinary skill in the art.

Referring now to FIGS. 18A and 18B, delivery and recapture of the medical device 300 described with respect to FIG. 15 is described. The medical device 300 is collapsed and retained within a slotted sleeve 340 associated with the catheter 310. The slotted sleeve 340 includes multiple fingers or elongated members 342 having free ends. The catheter 310 is guided to the LAA 102 (FIG. 1C) using techniques familiar to those of ordinary skill in the art. When the catheter 310 is in position for delivery of the medical device 300, the slotted sleeve 340 extends longitudinally out from an opening of the catheter 310. The fingers or elongated members 342 are configured to radially expand (due to self expansion, expansion due to the force applied by the medical device 300, or both), and the medical device is released from the slotted sleeve 342.

As will be appreciated by those of ordinary skill in the art, it is sometimes necessary to recapture the medical device 300 after deployment for purposes of repositioning the medical device within the LAA 102. In such a case, a tether 346 may be coupled to a plurality of ties 348 that circumscribe the body 302 of the medical device. The tether 346 and the web or cage formed by the ties 348 pull the medical device 300 back within the envelope defined by the radially expanded fingers 342 of the slotted sleeve 340. As the tether 346 and slotted sleeve 340 are drawn back in through the opening 344 of the catheter 310, the medical device 300 is returned to a collapsed state within the catheter 310 and may be redeployed into the LAA or removed completely from the patient. When the device 300 is satisfactorily position with the LAA 102, the tether may be disconnected from the ties 348.

-16-

In one embodiment, such ties 348 may be formed of a shape memory alloy, such as Nitinol, to assist in expansion of the medical device 300 in expanding when deployed in the LAA. The ties 348 may be disposed within recesses 306 of the medical device's textured surface. When deployed in an LAA 102, the ties 348 may remain with the body 302, although they may not be intended to serve any specific purpose in terms of anchoring the medical device 300 or promoting tissue growth. In another embodiment, instead of using ties 348 for recapture purposes, a mesh bag may be disposed about the body 302 of the medical device 300 in a manner similar to a further embodiment that is described hereinbelow.

10 In yet another embodiment, the slotted sleeve 340 need not be utilized. Instead, a pusher element (e.g., a rod or other device) may be inserted through the body 302 and configured to engage the distal end of the body 302. When it is desired to recapture the medical device 300, the pusher element may push against the distal end of the body while the ties are pulled toward the catheter 310 to effect an elongation (and a corresponding radial contraction) of the body 302. The medical device may then be drawn back within the catheter 310.

Referring now to FIGS. 19A and 19B, schematics are shown of a medical device 300 in a collapsed state (i.e., when in a catheter or other delivery vehicle), and an expanded state, respectively. Collapse of the medical device 300 may be assisted by ties 348 such as have been described above in terms of retaining the body 302 in a relatively compact form. When the medical device 300 is in a collapsed state, certain portions of its outer surface are in contact with the delivery vehicle. These areas are referred to herein as delivery contact surfaces and are generally indicated by reference numeral 350. It may be desirable to reduce the friction between these delivery contact surfaces 350 and the delivery vehicle. Thus, in certain instances, the size and shape of the protrusions 304 may be selectively tailored for such delivery contact surfaces 350.

In yet another embodiment, the protrusions 304 in the contact surface areas 350 may exhibit similar geometric configurations as the rest of the texture surface of the body 302. However, the surface areas not in contact with delivery vehicle (referred to as delivery non-contact surface indicated by reference numerals 352) may be modified by stiffening the material or further roughening the surface of the protrusions 304. For example, such delivery non-contact areas may be coated or metalized, such as with

-17-

graphite, to stiffen the protrusions 304 and provide a roughened surface area. These coated areas then provide improved engagement of the medical device 300 with the LAA wall 114 (FIG. 1C) when deployed in the LAA 102. Such coating or metallization can also serve another purpose to provide radio opacity for imaging purposes. Materials that can be used for such coating can be tungsten, platinum, gold or titanium or any other materials known in the art to provide radio opacity.

Referring now to FIGS. 20A through 20D, a medical device 360 according to another embodiment of the present invention is described. The medical device 360 includes a mesh bag 362 and a plurality of self-expanding bodies 364, such as foam bodies. The mesh bag 362 may be formed, for example, from nylon, polyester, knitted fiber, or some other appropriate material. In another embodiment, the bag 362 may be formed as a molded silicone material. As shown in FIG. 20A, the mesh bag 362 is delivered from a catheter 366 or other delivery mechanism into the LAA 102. Individual, self-expanding bodies 364 are then disposed into the mesh bag 362 from a separate sleeve or lumen of the catheter 366 as shown in FIGS. 20B and 20C. The expansion of the self-expanding bodies 364 stretches the mesh bag 362 such that the medical device 360 substantially conformally fills the LAA 102. Once the LAA is filled, the mesh bag 362 is tied off or otherwise securely closed to retain the self-expanding bodies 364 within the bag 362 and the LAA 102.

Use of a mesh bag 362 and multiple self-expanding bodies 364 again provides ease of use for the doctor deploying the medical device due to the fact that deployment is relatively insensitive to the approach angle of the catheter 366. Additionally, the use of multiple smaller expanding bodies 364 makes it more likely to substantially fill the LAA 102 in a generally conformal manner.

Various other features may be included in any of the above described embodiments. For example, radio opaque markers may be associated with any of a variety of components of the described medical devices to facilitate monitoring of the deployment and positioning of the medical device. Additionally, various materials may be used including bioresorbant materials for certain components. Further, various components may be coated to effect a desired biological reaction as will be appreciated by those of ordinary skill in the art.

-18-

The present invention may be embodied in other specific forms without departing from its spirit or essential characteristics. The described embodiments are to be considered in all respects only as illustrative and not restrictive. The scope of the invention is, therefore, indicated by the appended claims rather than by the foregoing
5 description.

-19-

CLAIMS

What is claimed is:

1. A medical device for modifying a left atrial appendage (LAA),
5 comprising:
a body formed of a self-expanding material, the body exhibiting a textured surface including a plurality of protruding portions and a plurality of recesses, each protruding portion being separated from an adjacent protruding portion by a recess of the plurality of recesses.
10
2. The medical device of claim 1, wherein the body, when in an expanded state, exhibits a substantially spherical geometry.
3. The medical device of claim 2, further comprising a substantially hollow
15 cavity defined within an interior of the body.
4. The medical device of claim 1, wherein the body is formed of a material comprising foam.
- 20 5. The medical device of claim 1, wherein the body is formed of a material comprising at least one of a polymer foam, polyurethane, polyester, and polyvinyl acetate.
6. The medical device of claim 1, wherein the body, when in an expanded state, substantially exhibits a geometry of a truncated sphere.
25
7. The medical device of claim 6, wherein an opening is defined within a surface at the truncated end of the sphere and wherein the opening exposes an internal cavity of the body.
- 30 8. The medical device of claim 1, further comprising a coating of metal or graphite on at least some of the protruding portions.

-20-

9. The medical device of claim 8, wherein, when in a collapsed state, the protruding portions that are intended to engage a surface of delivery mechanism are substantially devoid of any metal or graphite coating.

5

10. The medical device of claim 1, further comprising a mesh bag disposed about the body.

11. The medical device of claim 1, further comprising a plurality of ties circumscribing the body, wherein each tie is disposed in a recess of the plurality of recesses.

10

12. The medical device of claim 1, further comprising at least one radio opaque marker associated with the body.

15

13. A medical device for modifying a left atrial appendage (LAA), comprising:
a mesh bag;
at least one self-expanding body disposed within the mesh bag.

20

14. The medical device of claim 13, wherein the at least one self-expanding body includes a plurality of self-expanding bodies.

15. The medical device of claim 14, wherein the mesh bag is formed of a material comprising at least one of nylon, polyester or silicone.

25

16. The medical device of claim 14, wherein the plurality of self-expanding bodies includes a plurality of foam bodies.

17. The medical device of claim 16, wherein the plurality of foam bodies are formed of a material comprising at least one of a polymer foam, polyurethane, and polyvinyl acetate.

30

18. The medical device of claim 14, further comprising at least one radio opaque marker associated with the mesh bag or at least one of the plurality of self-expanding bodies.

5

19. A method of modifying a left atrial appendage (LAA), the method comprising:
providing a body formed of a self-expanding material, the body exhibiting a textured surface including a plurality of protruding portions and a plurality of recesses, each protruding portion being separated from an adjacent protruding portion by a recess of the plurality of recesses;
compressing the body within a delivery vehicle;
positioning a portion of the delivery vehicle adjacent an opening of the LAA;
discharging the body from the delivery vehicle into the LAA; and
expanding the body to engage a side wall of the LAA and substantially occlude an opening of the LAA.

10

15

20. A method of modifying a left atrial appendage (LAA), the method comprising:

20 disposing a mesh bag within the LAA;
disposing at least one self-expanding body within an interior of the mesh bag; and
securely closing the mesh bag to retain the at least one self-expanding body within the bag.

25

21. The method according to claim 20, wherein disposing at least one self-expanding body within an interior of the mesh bag further includes disposing a plurality of self-expanding bodies within the interior of the mesh bag.

30

22. A medical device for modifying a left atrial appendage (LAA),
comprising:
a first frame member having a first flat configuration and configured to anchor within the LAA;

-22-

- a second frame member having a second flat configuration, wherein the first and second frame members are non-coplanar;
- a spring member connected between the first frame member and the second frame member; and
- 5 a tissue in-growth member attached to the second frame member and configured to cover an opening of the LAA.

23. A medical device for modifying a left atrial appendage (LAA), comprising:
- 10 a frame member having a substantially flat configuration, the frame member including distal anchor members for anchoring the frame member within the LAA; and a tissue in-growth member attached to the frame member and configured to cover an opening of the LAA.

- 15 24. A medical device for modifying a left atrial appendage (LAA), comprising:
- a frame member including an anchoring system configured to anchor the frame member at least partially within the LAA; and
- a tissue in-growth member attached to the frame member and configured to prevent
- 20 potential embolic material from escaping the LAA.

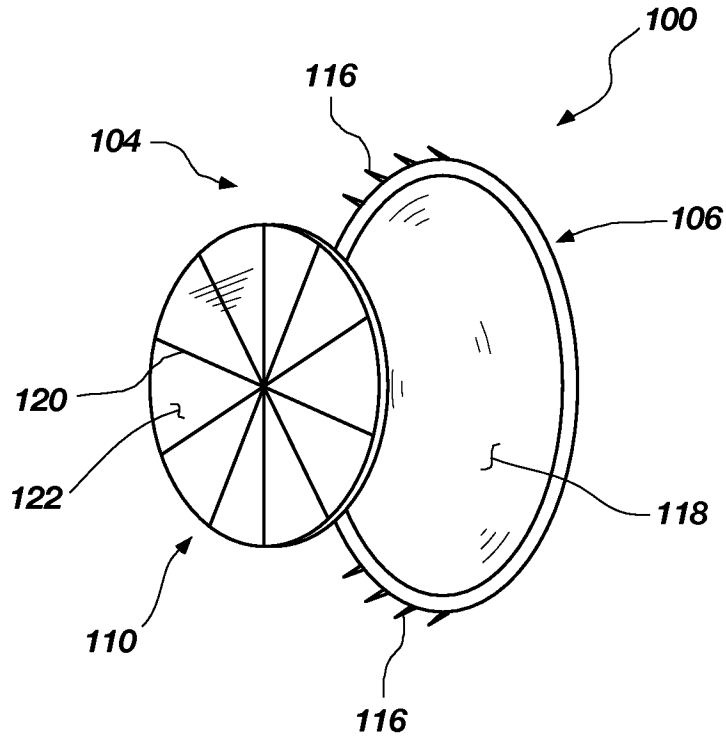

FIG. 1A

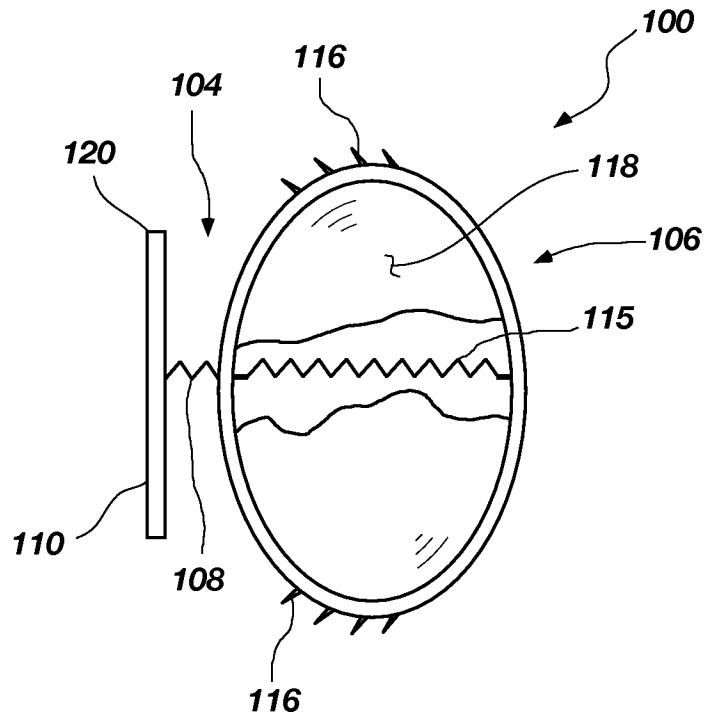

FIG. 1B

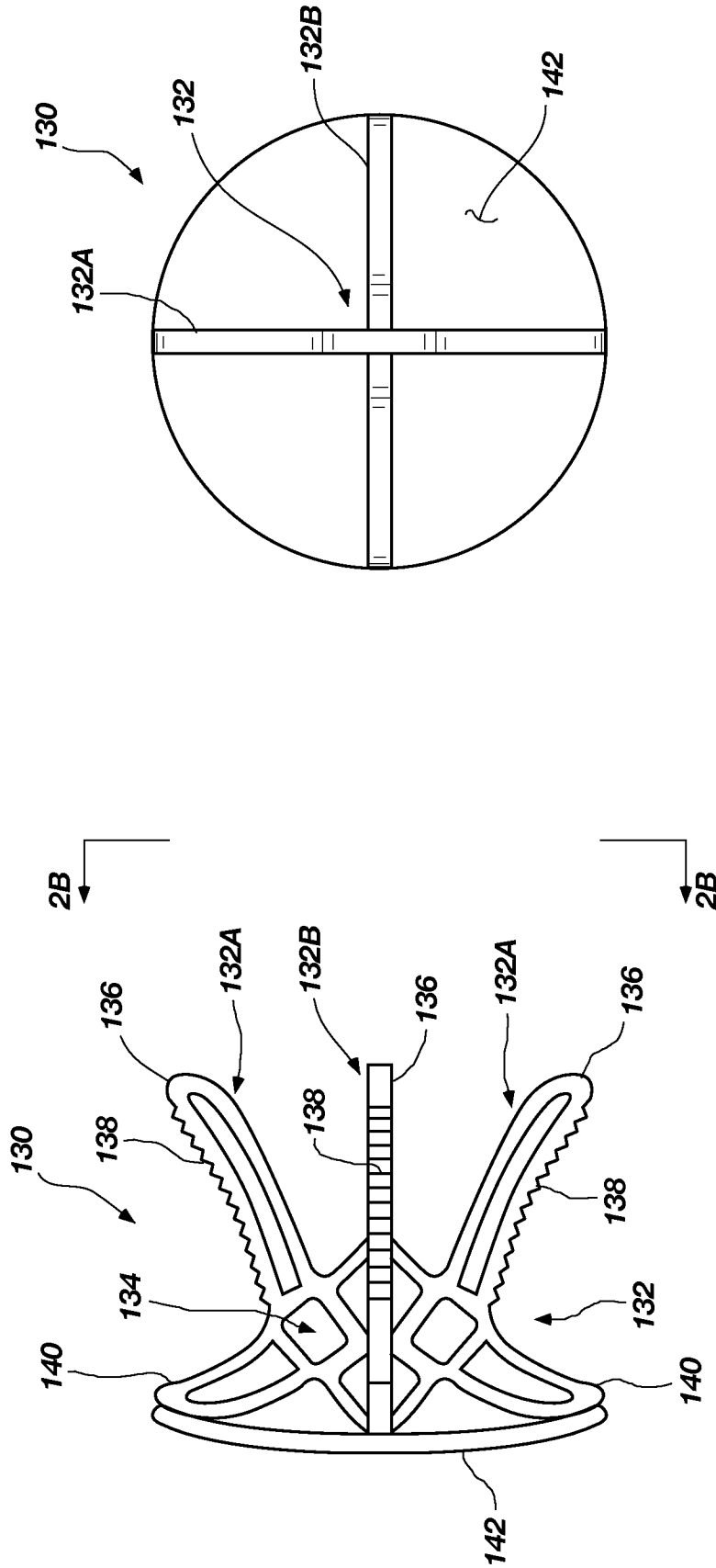

FIG. 2B

FIG. 2A

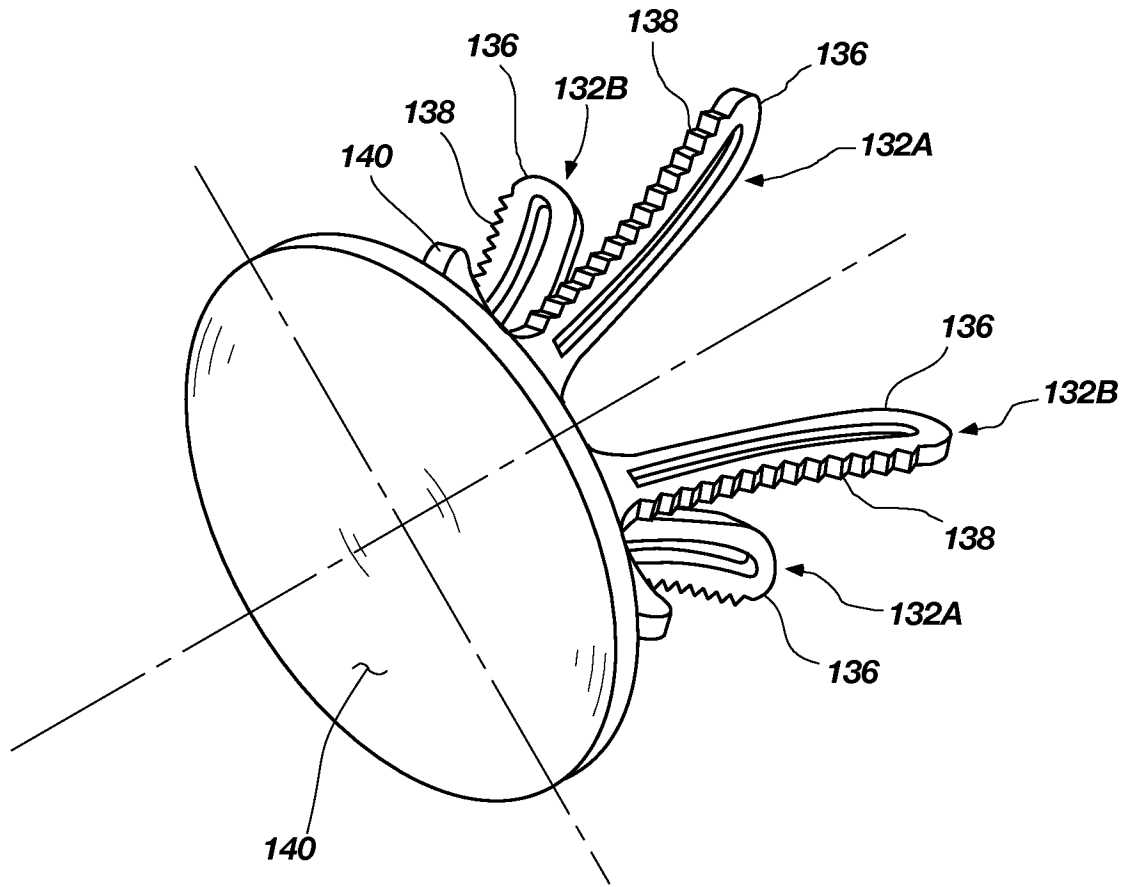

FIG. 2C

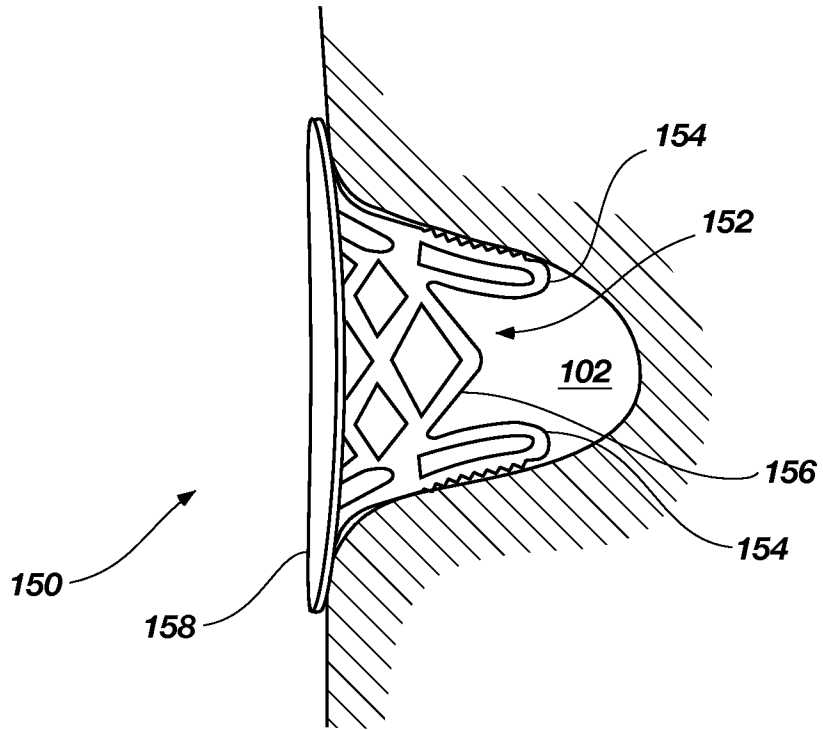

FIG. 3A

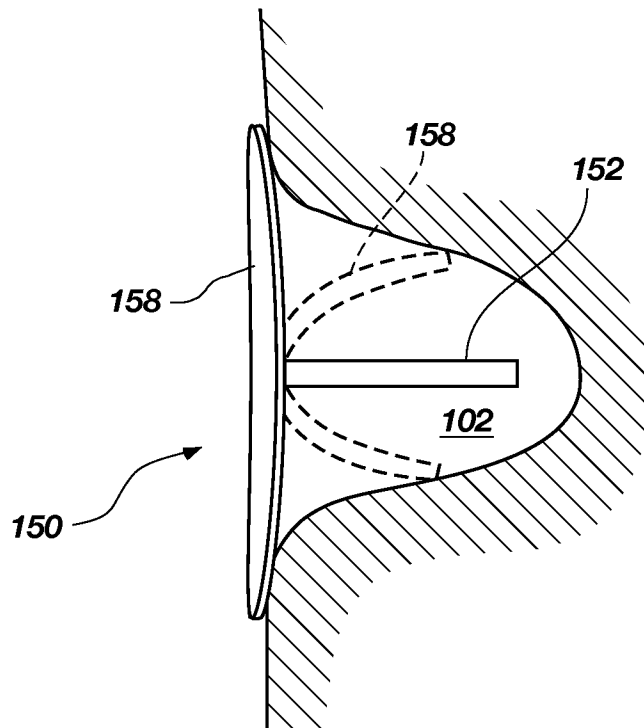

FIG. 3B

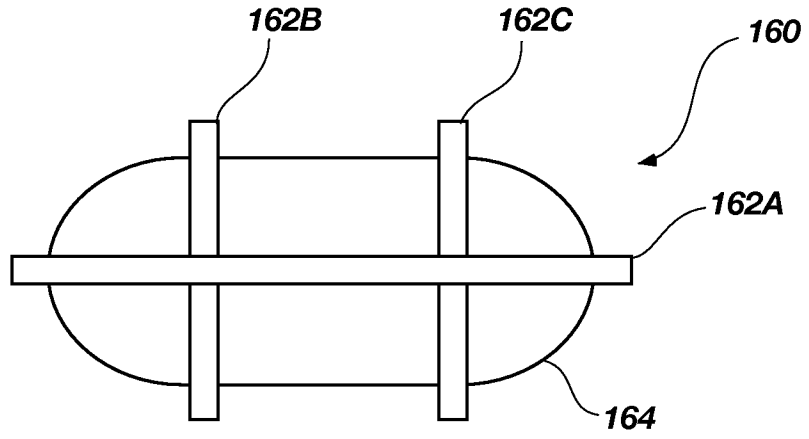

FIG. 4

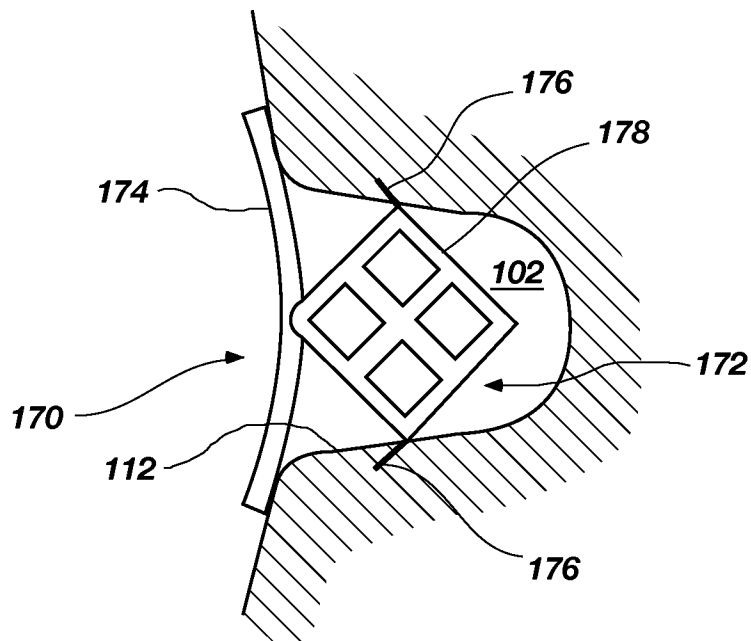

FIG. 5

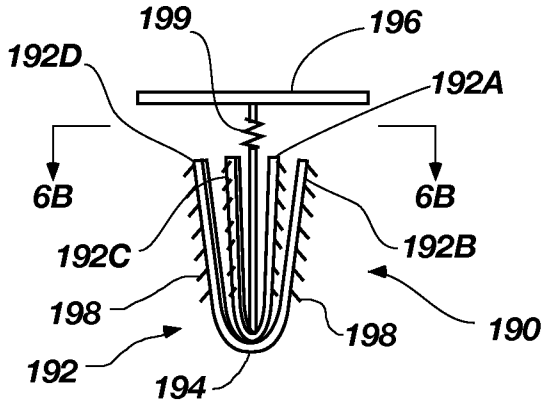

FIG. 6A

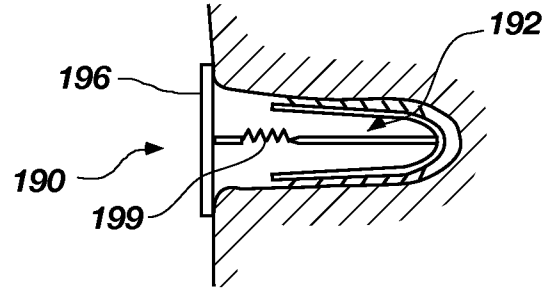

FIG. 6C

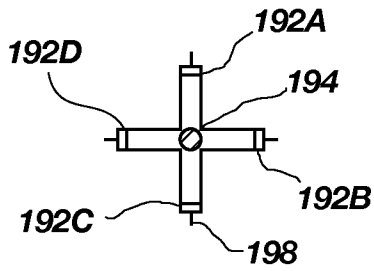

FIG. 6B

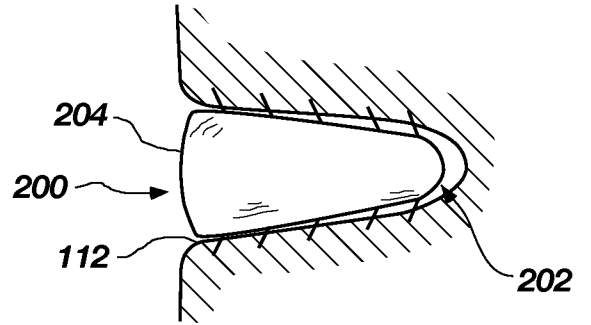

FIG. 7

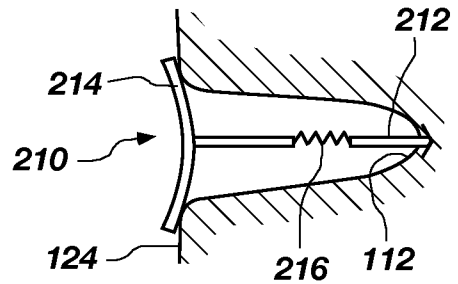

FIG. 8

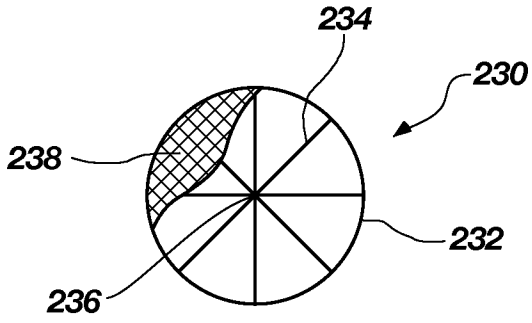

FIG. 9A

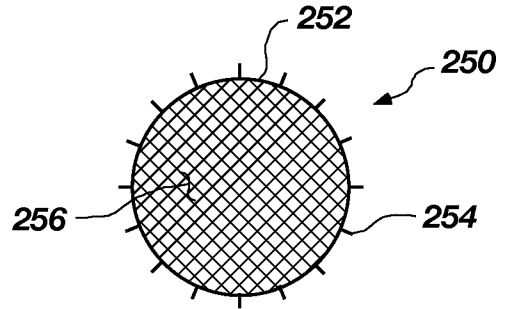

FIG. 10A

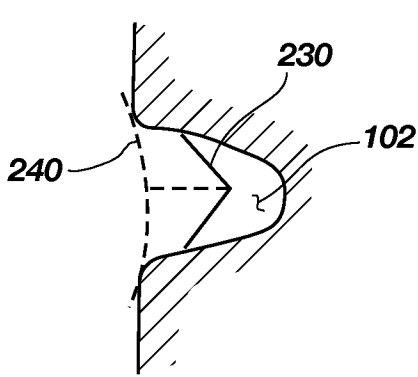

FIG. 9B

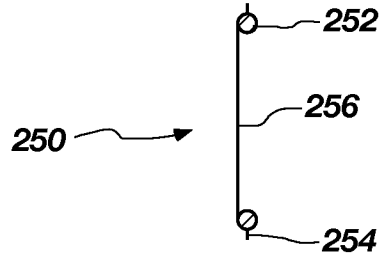

FIG. 10B

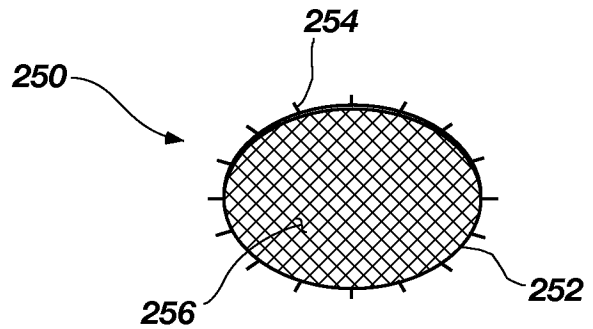

FIG. 10C

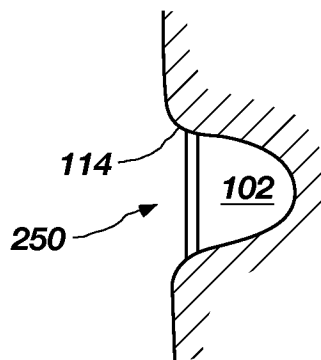

FIG. 10D

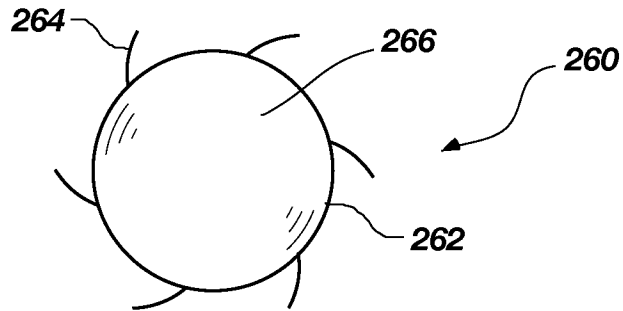

FIG. 11

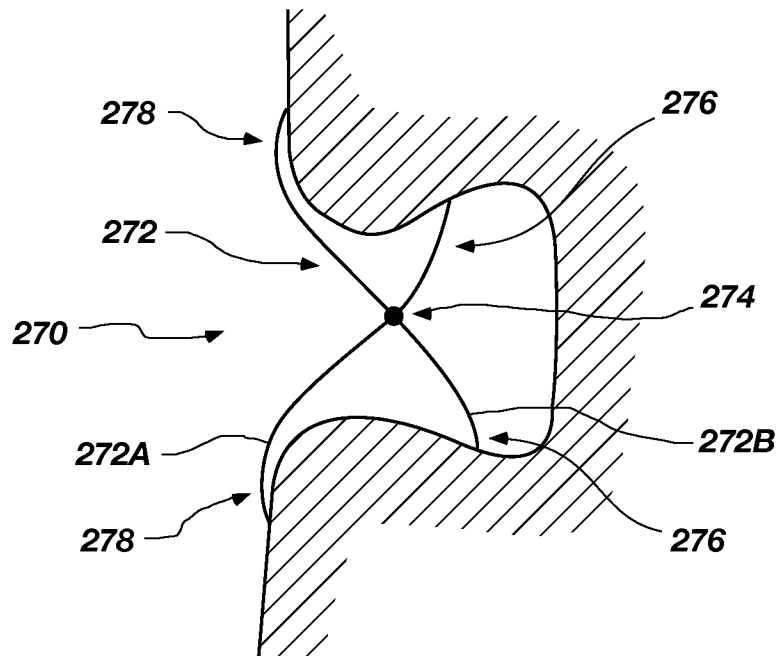

FIG. 12

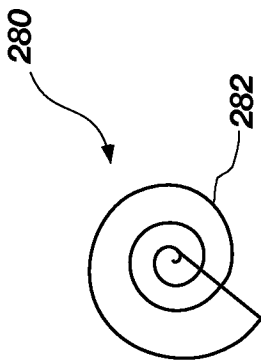

FIG. 13A

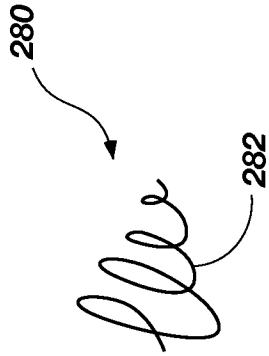

FIG. 13B

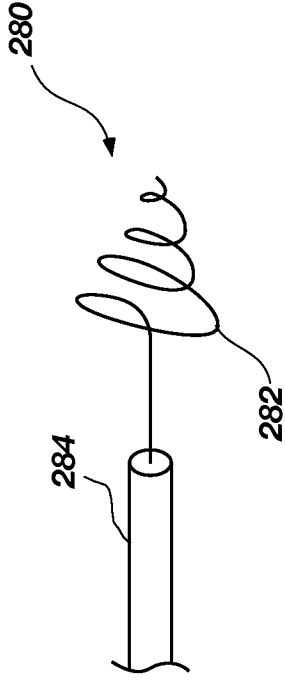

FIG. 13C

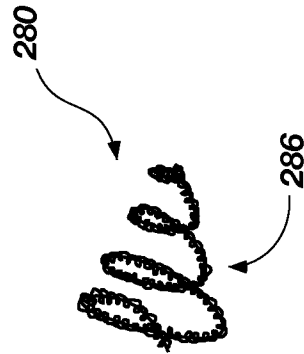

FIG. 13D

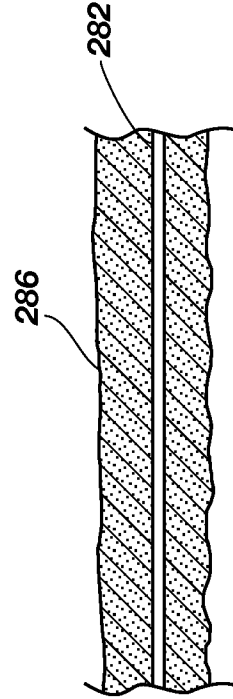

FIG. 13F

11/18

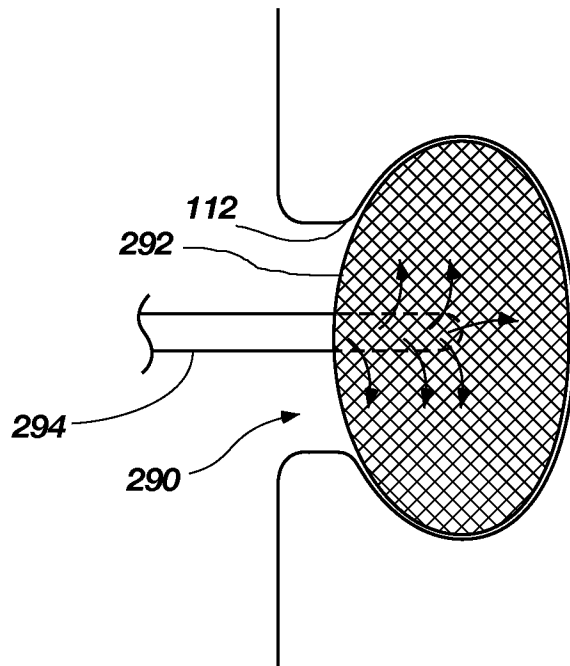

FIG. 14

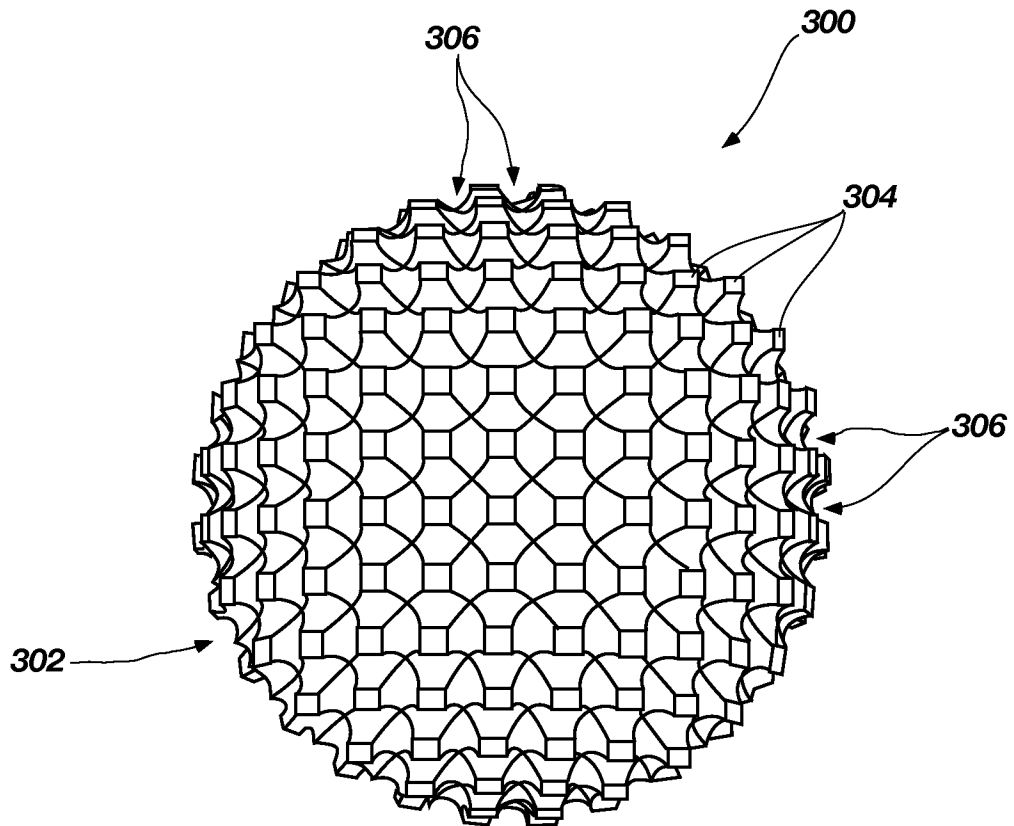

FIG. 15

12/18

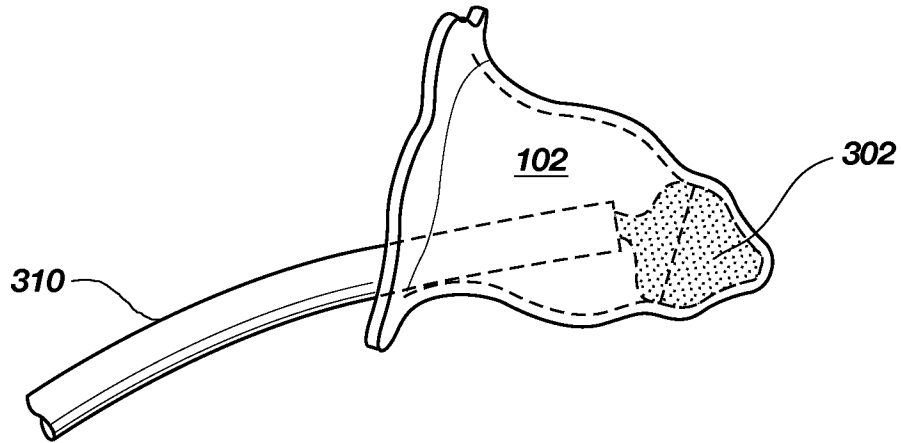

FIG. 16A

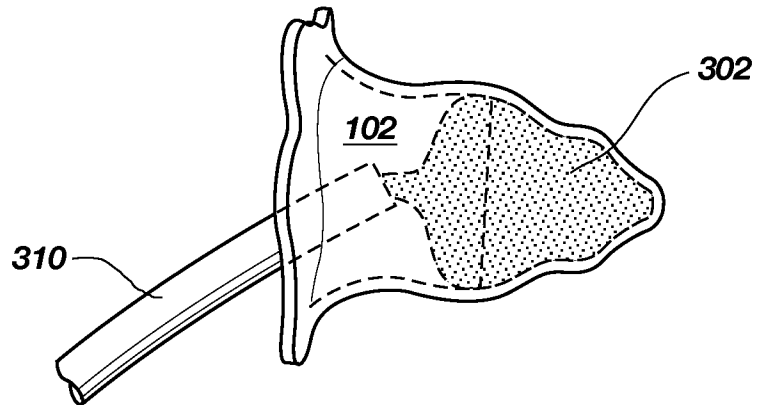

FIG. 16B

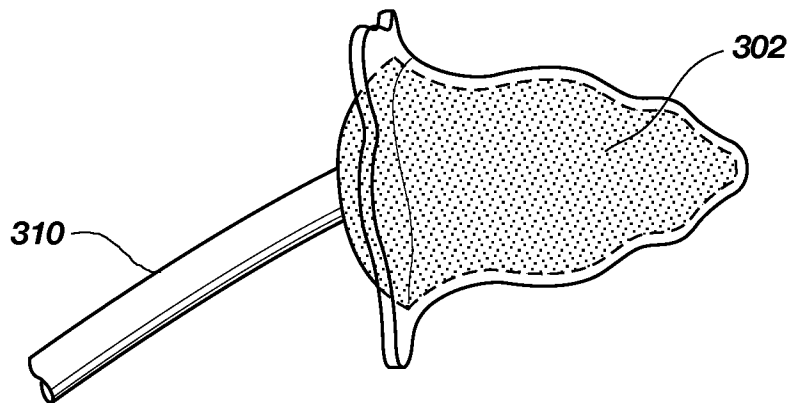

FIG. 16C

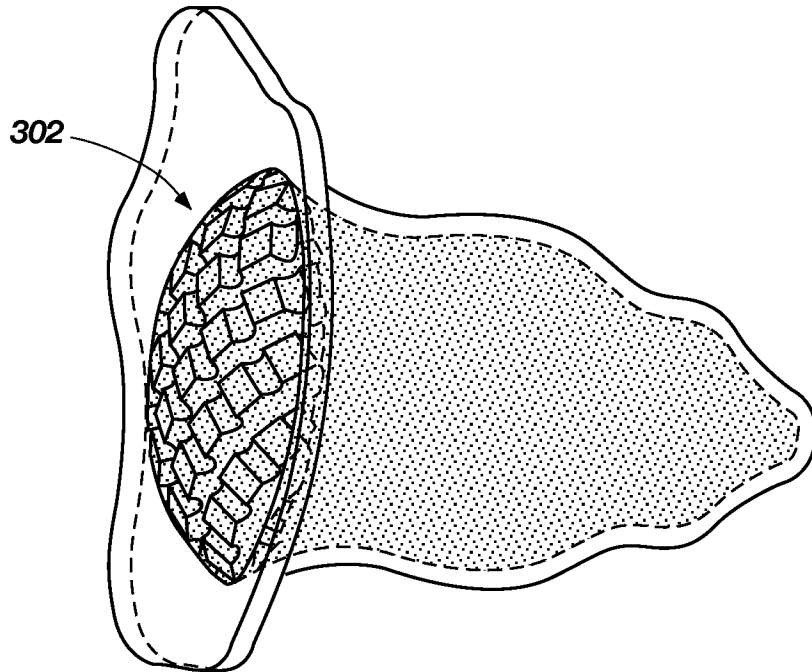

FIG. 16D

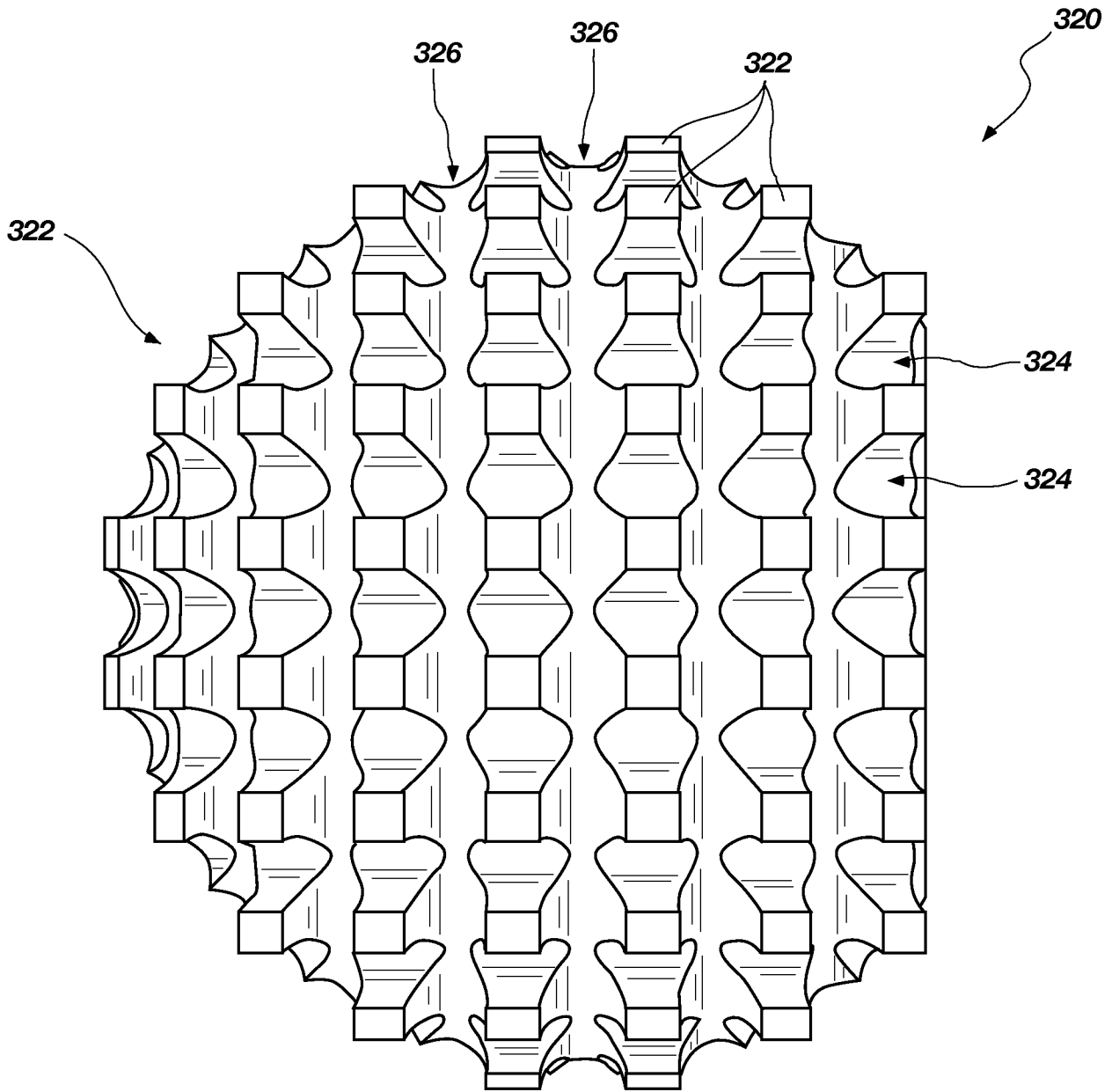

FIG. 17A

15/18

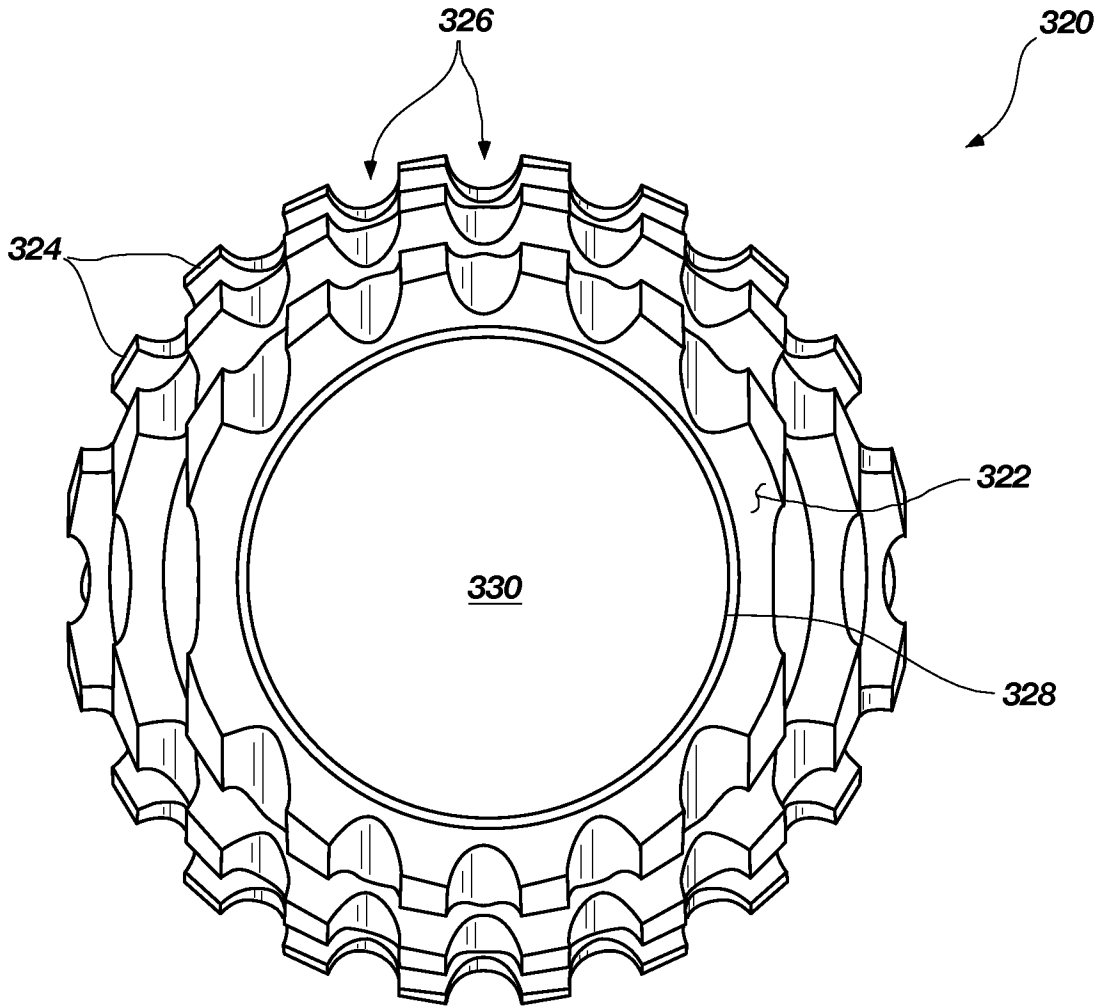

FIG. 17B

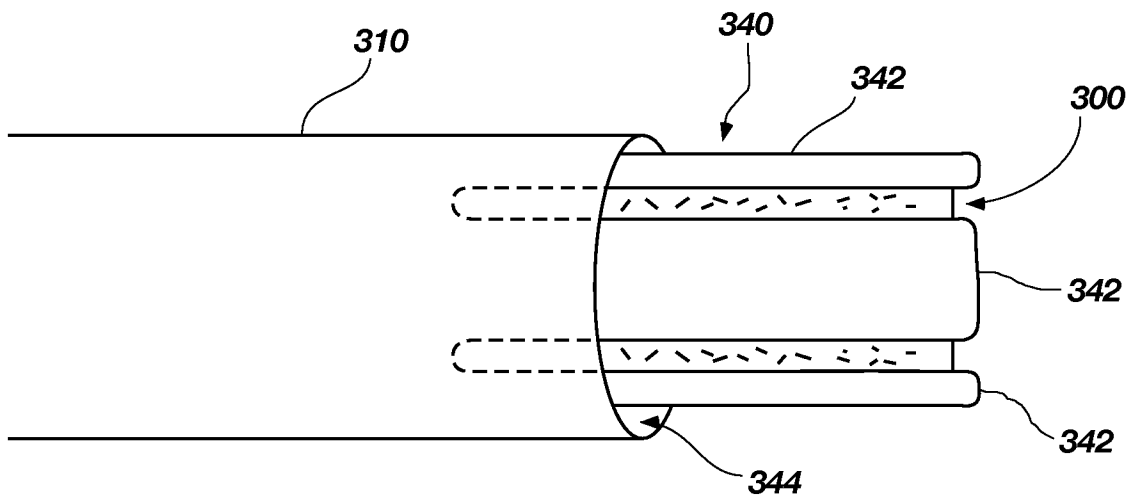

FIG. 18A

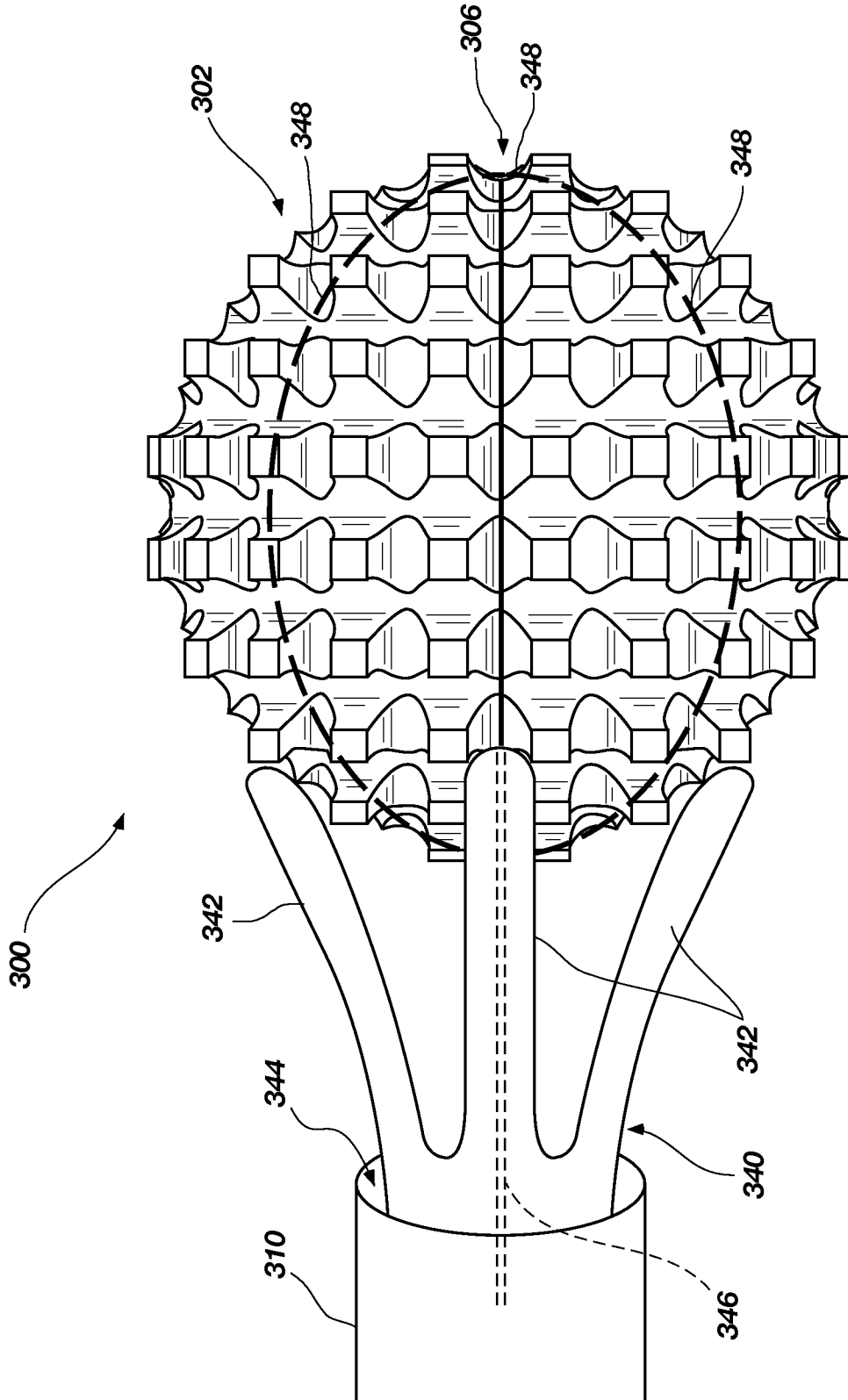

FIG. 18B

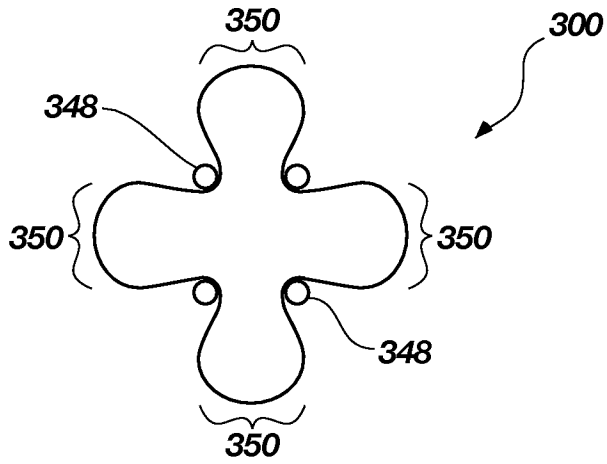

FIG. 19A

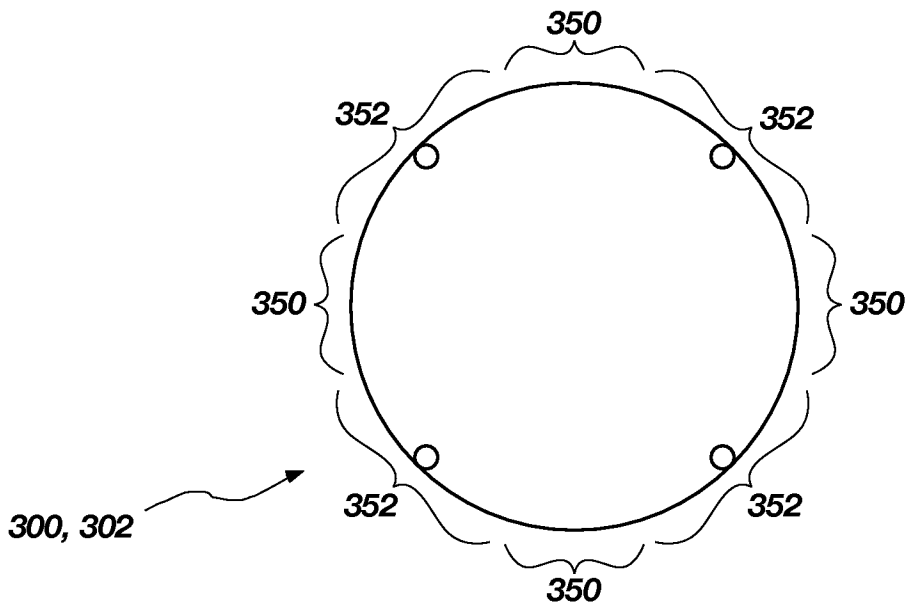

FIG. 19B

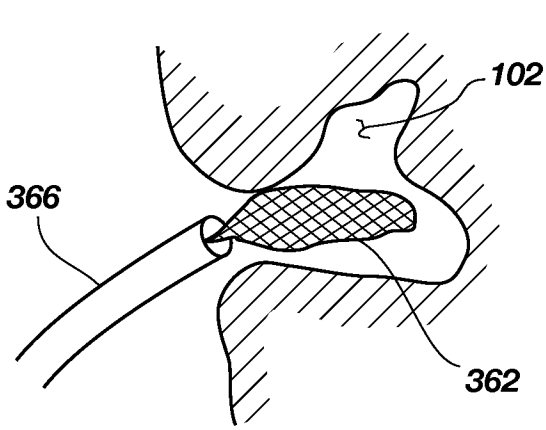

FIG. 20A

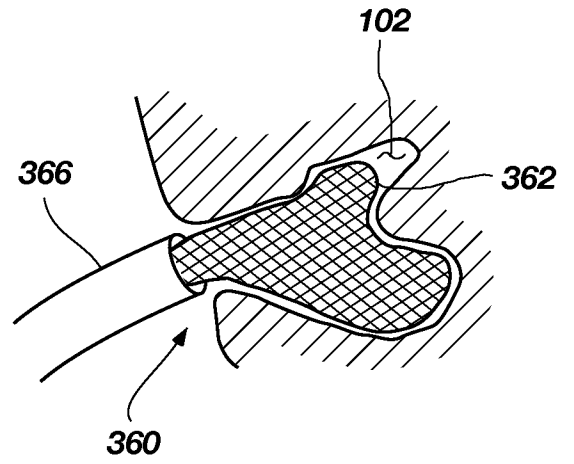

FIG. 20B

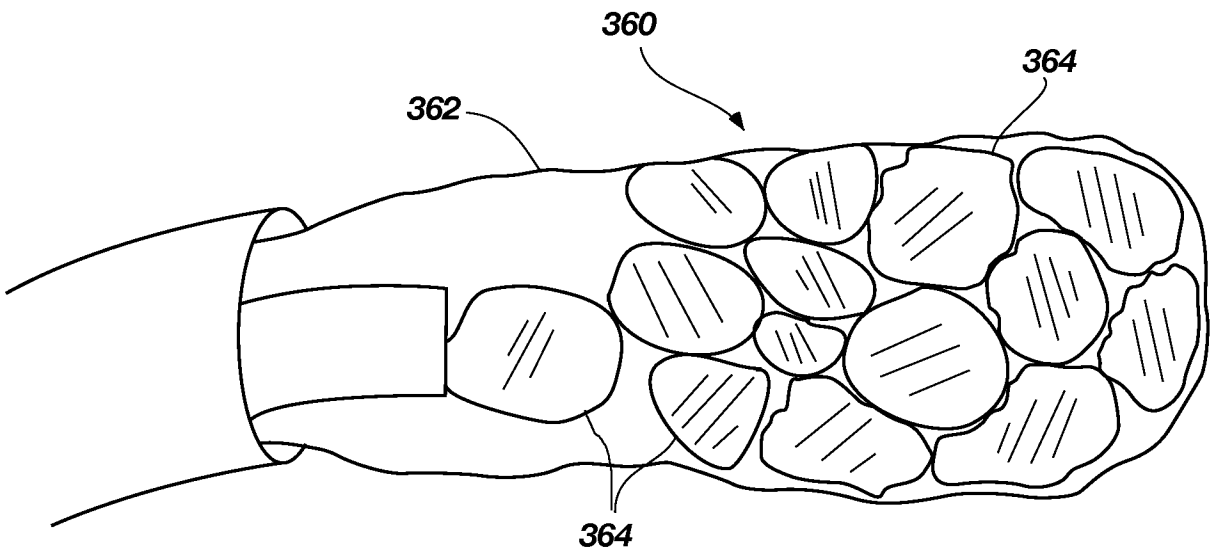

FIG. 20C

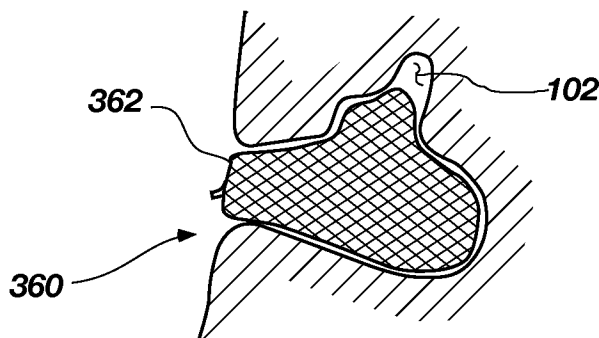

FIG. 20D