



INTERNATIONAL APPLICATION PUBLISHED UNDER THE PATENT COOPERATION TREATY (PCT)

<p>(51) International Patent Classification ⁶ : G07B 17/00, 17/04</p>	<p>A1</p>	<p>(11) International Publication Number: WO 99/66456 (43) International Publication Date: 23 December 1999 (23.12.99)</p>
<p>(21) International Application Number: PCT/US98/23097 (22) International Filing Date: 30 October 1998 (30.10.98) (30) Priority Data: 60/089,213 15 June 1998 (15.06.98) US (71) Applicant (for all designated States except US): ASCOM HASLER MAILING SYSTEMS, INC. [US/US]; 19 Forest Parkway, P.O. Box 858, Shelton, CT 06484-0904 (US). (72) Inventors; and (75) Inventors/Applicants (for US only): BROOKNER, George, M. [US/US]; 11 Surrey Drive, Norwalk, CT 06851 (US). CROWE, Allen, A. [US/US]; 76 Klein Drive, Prospect, CT 06712 (US). (74) Agents: LONDA, Bruce et al.; Londa and Traub LLP, 37th floor, 20 Exchange Place, New York, NY 10005 (US).</p>		<p>(81) Designated States: CA, JP, US, Eurasian patent (AM, AZ, BY, KG, KZ, MD, RU, TJ, TM), European patent (AT, BE, CH, CY, DE, DK, ES, FI, FR, GB, GR, IE, IT, LU, MC, NL, PT, SE). Published <i>With international search report.</i></p>

(54) Title: TECHNIQUE FOR GENERATING INDICIA INDICATIVE OF PAYMENT USING A POSTAL FUND

(57) Abstract

A payment system includes a label device (103), and a postal security device (PSD) (130) which stores postal funds for dispensing that may be replenished via electronic funds transfer. For example, the payment system performs functions other than just dispensing postal funds such as dispensing lottery tickets. In the case of dispensing postal funds, the label device (103) is programmed to generate indicia (400) onto label stock (403) which serves as proof of postage after deducting the corresponding postage amount to be dispensed from the postal funds stored in the PSD (130). In the case of dispensing lottery tickets, the label device (103) is programmed to connect to a lottery server over a communications network and to transmit transaction data concerning the selected lottery numbers (1207), payment for the lottery entry, etc. to the lottery server. Accordingly, the payment system deducts the payment amount corresponding to the lottery entry from the postal funds stored in the PSD (130). In return the payment system receives, from the lottery server, data concerning indicium (1300). Label device (103) then uses the received data to print indicium (1300) on label stock (1303), thereby producing a lottery ticket.

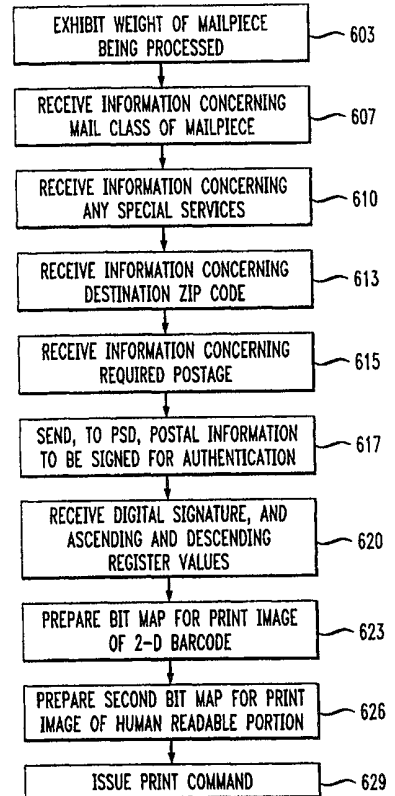

FOR THE PURPOSES OF INFORMATION ONLY

Codes used to identify States party to the PCT on the front pages of pamphlets publishing international applications under the PCT.

AL	Albania	ES	Spain	LS	Lesotho	SI	Slovenia
AM	Armenia	FI	Finland	LT	Lithuania	SK	Slovakia
AT	Austria	FR	France	LU	Luxembourg	SN	Senegal
AU	Australia	GA	Gabon	LV	Latvia	SZ	Swaziland
AZ	Azerbaijan	GB	United Kingdom	MC	Monaco	TD	Chad
BA	Bosnia and Herzegovina	GE	Georgia	MD	Republic of Moldova	TG	Togo
BB	Barbados	GH	Ghana	MG	Madagascar	TJ	Tajikistan
BE	Belgium	GN	Guinea	MK	The former Yugoslav Republic of Macedonia	TM	Turkmenistan
BF	Burkina Faso	GR	Greece			TR	Turkey
BG	Bulgaria	HU	Hungary	ML	Mali	TT	Trinidad and Tobago
BJ	Benin	IE	Ireland	MN	Mongolia	UA	Ukraine
BR	Brazil	IL	Israel	MR	Mauritania	UG	Uganda
BY	Belarus	IS	Iceland	MW	Malawi	US	United States of America
CA	Canada	IT	Italy	MX	Mexico	UZ	Uzbekistan
CF	Central African Republic	JP	Japan	NE	Niger	VN	Viet Nam
CG	Congo	KE	Kenya	NL	Netherlands	YU	Yugoslavia
CH	Switzerland	KG	Kyrgyzstan	NO	Norway	ZW	Zimbabwe
CI	Côte d'Ivoire	KP	Democratic People's Republic of Korea	NZ	New Zealand		
CM	Cameroon			PL	Poland		
CN	China	KR	Republic of Korea	PT	Portugal		
CU	Cuba	KZ	Kazakstan	RO	Romania		
CZ	Czech Republic	LC	Saint Lucia	RU	Russian Federation		
DE	Germany	LI	Liechtenstein	SD	Sudan		
DK	Denmark	LK	Sri Lanka	SE	Sweden		
EE	Estonia	LR	Liberia	SG	Singapore		

-1-

DescriptionTechnique for Generating Indicia
Indicative of Payment Using a Postal FundTechnical Field

The invention relates to payment systems and methods, and more particularly to a system and method for generating indicia onto a medium, e.g., a label, serving
5 as proof of payment, e.g., postage.

Background of the Invention

Use of a postage meter or franking machine to generate a postage mark or indicium serving as proof of payment of postage is ubiquitous. The format of such a
10 postage indicium is specified by a postal authority to facilitate its inspection.

In the United States, much attention has been focused on an Information-Based Indicia Program (IBIP) by the United States Postal Service (USPS), proposing, among
15 other things, new requirements for the format of a postage indicium. Such new requirements were promulgated, e.g., in the "Information Based Indicia Program (IBIP) Open System Indicium Specification", dated July 23, 1997. For instance, the IBIP requires inclusion
20 of a 2-dimensional (2-D) barcode in the postage indicium. Such a barcode represents postal information including postage, and a digital signature for authenticating the postal information, in accordance with a public key algorithm. One such public key algorithm may be the
25 Digital Signature Algorithm (DSA) described, e.g., in "Digital Signature Standard (DSS)," FIPS PUB 186, May 19, 1994.

In addition, under the IBIP, the requirements of a postal security device (PSD) supporting the creation
30 of the postage indicium are specified, e.g., in the "Information Based Indicia Program (IBIP) Open System

-2-

Postal Security Device (PSD) Specification," dated July 23, 1997. In accordance with the IBIP requirements, the PSD provides the aforementioned digital signature in the postage indicium, and dispenses and accounts for a postal fund stored therein in a secure manner. The PSD includes a descending register and an ascending register. In a conventional manner, the descending register is used to keep track of the amount of the postal fund available for dispensation. On the other hand, the ascending register is used to keep track of the amount of postage dispensed. When the value of the descending register decreases over time below a predetermined limit, the PSD can no longer dispense postage until the descending register is reset. For example, such a reset may be achieved by way of electronic funds transfer via a dial-up connection with a computerized central facility, in accordance with a well-known telemeter setting (TMS) technique.

Summary of the Invention

We have recognized that the PSD actually functions as a "virtual bank" or an "electronic purse," as it stores a postal fund for ready dispensation, which may be replenished via a TMS transaction. In accordance with an aspect of the invention, a payment system incorporating the PSD is used to realize a financial transaction as well as postage dispensation. For example, the payment system may establish a communications connection to a server system to conduct a financial transaction therewith. The financial transaction may involve a payment to the server system in return for a service or product. In that case, the payment amount is deducted from the postal fund. The payment system then transmits, to the server system, first data concerning at least the payment amount, and receives, from the server system, second data concerning an indicium. The indicium may be printed by the payment system and serves as proof of payment or purchase.

-3-

In accordance with another aspect of the invention, the payment system includes a label device which prints indicia, e.g., postage indicia, on a roll of label stock. The label device communicates with the PSD
5 to account for the payment, e.g., postage, indicated by each indicium before it is printed on the label stock.

It is an object of the invention to secure the payment system, and protect it from an external intrusion to drive a print head assembly therein to fraudulently
10 print indicia indicative of payments unaccounted for by the PSD. Accordingly, part of the payment system including a connection transporting signals to the print head assembly is encapsulated by potting material. In accordance with yet another aspect of the invention, the
15 potting material is highly thermoconductive to help dissipate heat from the encapsulated part, thereby preventing it from an overheat condition and prolonging its lifetime.

It is another object of the invention to avoid
20 use of fluorescent ink to print a postage indicium as in prior art, which is relatively expensive. In accordance with another aspect of the invention, fluorescent marking is provided on the label stock, which is relatively inexpensive, and postage indicia may be printed in non-
25 fluorescent ink on such label stock, thereby satisfying the postal authority's requirement of use of fluorescence for determination of the facing and orientation of the mailpiece onto which the printed postage indicium is applied.

30 It is yet another object of the invention to maintain the integrity of the postal data contained in a printed postage indicium as the indicium may be exposed to unfavorable conditions, e.g., rain, when they are in transit to the postal authority for inspection thereof.
35 In accordance with yet another aspect of the invention, a backup code is included in or near the postage indicium for fear that the postal data in the postage indicium is

corrupted. The backup code is designed to help recover at least part of the postal data to facilitate the inspection and delivery of the mailpiece associated therewith.

5 It is still another object of the invention to facilitate mailing of a mailpiece onto which a postage indicium is applied. In accordance with still another aspect of the invention, a mailing address for the same mailpiece is printed on a first label, and the postage
10 indicium is printed on a second label using the inventive label device. Preferably, the labels are dispensed in pairs. An indication for associating the first label with the second label is printed on at least one of the first and second labels. For example, the indication may
15 be the destination zip code in the mailing address, and printed on the second label. As the destination zip code is naturally part of the mailing address printed on the first label, one can readily match up the first label with the second label based on the indication and apply
20 the labels onto the same mailpiece.

Brief Description of the Drawing

Further objects, features and advantages of the invention will become apparent from the following detailed description taken in conjunction with the
25 accompanying drawing, in which:

Fig. 1 is a block diagram of a payment system in accordance with the invention;

Fig. 2A provides a cross-sectional view of a label device in the system of Fig. 1;

30 Fig. 2B illustrates an alternative arrangement for the label device;

Fig. 3 is a block diagram of a postal security device in the system of Fig. 1;

35 Fig. 4 illustrates a label which contains a postage indicium and which is generated by the system of Fig. 1;

Fig. 5 illustrates a user interface in the system of Fig. 1;

Fig. 6 is a flow chart depicting a process for generating the label of Fig. 4;

5 Fig. 7 illustrates a label which contains a backup code in addition to the postage indicium, and which is generated by the system of Fig. 1;

Fig. 8 illustrates a first configuration involving the system of Fig. 1;

10 Fig. 9 illustrates a second configuration involving the system of Fig. 1;

Fig. 10 illustrates label material containing paired labels for use in the system of Fig. 1;

15 Fig. 11 is a flow chart depicting a process for printing a mailing address on a first label and a postage indicium on a second label associated therewith;

Fig. 12 is a flow chart depicting a process for conducting a secure financial transaction using the system of Fig. 1; and

20 Fig. 13 illustrates a label which serves as a lottery ticket and which is generated by the system of Fig. 1.

Throughout the figures of the drawing, the same reference numerals and characters are used to denote like features, elements, components or portions of the
25 illustrated system.

Detailed Description

Fig. 1 is a block diagram of payment system 100 incorporating the principles of the invention. By way of
30 example, but not limitation, payment system 100 is illustratively used for mailing purposes, whereby postage indicia are generated onto a medium, e.g., label stock.

In this illustrative embodiment, system 100 includes label device 103 and postal security device
35 (PSD) 130. Processor 105 in device 103 is programmed to orchestrate the operation of system 100. The program

routines containing instructions for processor 105 to effect the system operation are stored in memory 109. Operating portion 111 includes a user interface described below, and a dispenser mechanism of conventional design for feeding the label stock to printing mechanism 115. For example, the label stock may be in the form of a continuous tape or individual labels, and may be self-adhesive and liner protected or linerless, or may require moistening for affixing purposes. The label material may be of opaque, translucent, or transparent composition. Under control of processor 105, printing mechanism 115 prints on the label stock, received from operating portion 111, indicia serving as proof of payment of postage in this instance.

For mailing purposes, device 103 in this illustrative embodiment includes weighing mechanism 117 described below for weighing mailpieces to determine their proper postage. Device 103 also includes interface 120 for connection with an external device, e.g., an electronic scale. While mechanism 117 may be used for determining the weight of a relatively flat and light mailpiece, the external electronic scale may be used for determining that of a relatively bulky and heavy one. In addition, device 103 may include communications interface 125 for connection with a personal computer (PC), workstation, or other general purpose computing machine. Moreover, device 103 in this instance includes PCMCIA and/or serial (PCMCIA/serial) interface 127 for connection with postal security device (PSD) 130, which is realized as an integrated circuit (IC) card or a "smart" module peripheral to device 103.

Fig. 2A provides a cross-sectional view of label device 103. As shown in Fig. 2A, device 103 includes housing 201, cover 203, printed circuit board (PCB) 205, print head assembly 207 in printing mechanism 115, and dispenser mechanism 209 in operating portion 111 for dispensing a roll of label stock, denoted 211.

-7-

Device 103 also includes mailpiece holder 215, spacer 217 and load cell 219, together constituting weighing mechanism 117. Holder 215 has cavity 230 for insertion of a mailpiece thereinto, and is securely disposed on top of spacer 217 which conducts the weight of the mailpiece to measuring device 219, e.g., a load cell. In a well known manner, device 219 senses the mailpiece weight and outputs an electrical signal representing same. The control and data signals including the weight signal between weighing mechanism 117 and processor 105 are communicated through cable 232 which terminates on PCB 205. The latter comprises electrical circuitry connected to processor 105. Through cable 235, processor 105 communicates the necessary control and data signals with dispenser mechanism 209 and print head assembly 207.

However, in this illustrative embodiment, cable 235 is not secure and is subject to external intrusion. In particular, the data and control signals exchanged between processor 105 and print head assembly 207 through cable 235 are subject to interception and possible tampering. To reduce the risk of any such external intrusion to drive print head assembly 207 to fraudulently print postage which would otherwise be unaccounted for by PSD 130, an alternative embodiment where use of cable 235 is eliminated will now be described.

Referring to Fig. 2B, in this alternative embodiment, print head assembly 207 is disposed close to processor 105 on PCB 205 and connected thereto through pins 280. A roll of label stock 211 is dispensed by rotating platen 285 driven by a gear assembly and control motor, e.g., step motor (not shown). Print head assembly 207 prints on label material against platen 285 as the label material comes in contact with assembly 207. In accordance with an aspect of the invention, part of assembly 207, including pins 280, and processor 105 are potted with hard, opaque potting material 287 (indicated

by a dash line), e.g., epoxy, thereby encapsulating and sealing them from unwanted external intrusions. In accordance with a further aspect of the invention, potting material 287 is selected to be of the type of high thermal conductivity so that it also functions as a heat sink to help dissipate heat from the encapsulated components. One such potting material particularly suitable for heat dissipation is INSULCAST 147 FR epoxy manufactured by Insulcast, Roseland, New Jersey.

10 It should be noted that any attempt to intrude upon pins 280 to tamper with the signals transported thereby to print head assembly 207 would be evidenced by visible breakage of potting material 287. Notwithstanding such, to effectively thwart any such tampering attempt, in accordance with a still further aspect of the invention, signal carrier 289, e.g., a breakable wire conducting an electrical signal or optical fiber transporting an optical signal, is also encapsulated in potting material 287 and spread in the area of print head assembly 207 and processor 105 which requires protection from tampering attempts. In this alternative embodiment, instead of having PSD 130 external to label device 103, the hardware of PSD 130 including a cryptographic processor and a secure memory described below may reside on PCB 205 and also encapsulated in potting material 287 to be protected from an unwanted intrusion thereon.

As shown in Fig. 2B, both ends of carrier 289 are terminated onto control logic 291 of conventional design which is also encapsulated in potting material 287. In a well known manner, control logic 291 operates in one of two states, wherein a first state corresponds to carrier 289 being intact, i.e., unbroken, under the normal condition, and a second state corresponds to carrier 289 being broken as a result of an unwanted intrusion. In this instance, control logic 291 controls through processor 105 the operation of device 103. Under the normal condition, control logic 291 operates in the

first state and maintains the normal operation of device 103. However, when carrier 289 is broken because of a tampering attempt, control logic 291 accordingly switches to the second state where the operation of device 103 is terminated, thereby thwarting the tampering attempt. The resetting of device 103 to operation after its termination may call for special procedures which necessitate intervention by an authority.

Referring to Fig. 3, PSD 130 includes PCMCIA and/or serial (PCMCIA/serial) interface 301 for interfacing with and insertion into device 103, cryptographic processor 305, and secure memory 307. The components in PSD 130 may be realized using a chip set of the type of the NETARMOR VMS310 chip set manufactured by VLSI Technology, Inc, or alternatively a chip set typified by smart card technology.

Secure memory 307 is a nonvolatile memory for storing, among others, information concerning an amount of a postal fund available for payment. For mailing purposes, memory 307 includes a descending register and an ascending register. The descending register is used to keep track of the postal fund amount available for postage dispensation. On the other hand, the ascending register is used to keep track of an amount of postage dispensed. When the value of the descending register decreases over time below a predetermined limit, system 100 can no longer dispense postage until the descending register is reset. Such a reset may be achieved by way of electronic funds transfer, in accordance with a well-known telemeter setting (TMS) technique, via a dial-up connection with a computerized central facility using a modem (not shown), e.g., an external modem connected to interface 120 or a built-in modem in a PC connected to interface 125.

Using the TMS technique in this instance, the user need not carry PSD 130 to a postal authority for authorized resetting of the descending register. To

-10-

initiate a TMS process in system 100, the user may be required to enter a key or password on the user interface described below in operating portion 111. Verification of the password entry ensures that the user is authorized to conduct such a process. After the password entry is verified, processor 105 initiates a call through the aforementioned modem to the computerized central facility, also known as the "TMS host system" in this instance, requesting an additional postal fund. Upon receipt of the call, the TMS host system verifies specified encrypted data or digitally signed data stored in secure memory 307 of PSD 130, and ascertains the availability of fund in the user's prefunded escrow account. After the encrypted data or digital signed data is validated and the escrow fund is found to be sufficient, the TMS host system debits the user's account and remotely resets the descending register in PSD 130 accordingly. A message is then communicated to processor 105, confirming the funds transfer.

It will be appreciated that the postal fund stored in PSD 130 may also be recharged at an automatic teller machine (ATM) or a similar machine using an ATM card, a credit card, debit card, charge card, telephone calling card, telephone prepaid card or prepaid transit fare card, or at a vending machine using cash; or recharged using other funds transfer techniques including electronic funds transfer (EFT) via a private network, the ATM network, the EFT network, the Internet, etc.

In this particular illustrative embodiment, secure memory 307 also includes a well known digital signature algorithm (DSA), a private key and the corresponding public key in accordance with the DSA. Other well known algorithms alternative to the DSA include the RSA and Elliptic Curve algorithms. The public key may be made available to the public in a PSD certificate. For instance, using the DSA, cryptographic processor 305 may sign specified postal data with the

-11-

private key to generate a digital signature to be included in a postage indicium. The PSD certificate containing the public key may also be provided in the indicium for the postal authority to verify the digital signature to authenticate the postage indicium.

Fig. 4 illustrates postage indicium 400 which serves as proof of postage and is generated by system 100 onto label 403. Label 403 is part of the label stock dispensed by operating portion 111. Indicium 400 consists of human readable portion 405, machine readable portion 410. Illustratively, portion 405 includes information concerning the date of mailing, postage, device ID which identifies system 100, origination town and zip code, mail class, etc. Machine readable portion 410 includes a 2-D barcode representing the postal data required by the postal authority, and the digital signature for authenticating the indicium as mentioned before. Such a 2-D barcode is readable by an optical scanner. In this particular illustrative embodiment, the 2-D barcode, in accordance with the well known Uniform Symbology Specification PDF 417, represents such postal data as the device ID which identifies system 100, ascending register value, postage, digital signature, date of mailing, originating address licensing zip code, software ID which identifies application software including the aforementioned program routines in system 100, descending register value, PSD certificate, mail class, etc.

In addition, in accordance with another aspect of the invention, fluorescent marking, e.g., a fluorescent stripe, is preprinted on a label before an indicium is printed thereon, or printed along with the indicium. For example, as shown in Fig. 4, fluorescent stripe 415 is printed along an edge of label 403. Stripe 415 contains fluorescent ink, which enables the postal authority when scanning a mailpiece on which label 403 is applied to determine the facing of the mailpiece and

-12-

orientation thereof in a mail stream, as required by the postal authority. Advantageously, with fluorescent stripe 415, printing of postage indicium 400 in fluorescent ink indicating the mailpiece's facing and orientation as in prior art, which is relatively expensive, is no longer required. That is, with florescent stripe 415, a user is free to print postage indicium 400 in non-fluorescent ink, which is relatively inexpensive. It should be noted that depending on the fluorescent ink used, fluorescent stripe 415 may or may not be visible.

It should also be noted that if the label stock used in label device 103 is in the form of a continuous tape, the aforementioned fluorescent marking may comprise a continuous stripe or marks punctuated along an edge of the tape-label. In the event that the label stock used is in the form of individual labels on a backing separated from one another by a gap, it is advantageous to have fluorescent marking preprinted on the individual labels only. In accordance with another aspect of the invention, such preprinted fluorescent marking is positioned on an individual label such that the leading edge of the marking coincides with that of a postage indicium to be printed on the label, thereby properly positioning the postage indicium thereon. To that end, an optical sensor (not shown) in operating portion 111 which is sensitive to fluorescence is used to detect the leading edge of the fluorescent marking on each label. As soon as such a leading edge is detected, the optical sensor sends a signal to processor 105 which then causes printing mechanism 115 to start generating the postage indicium onto the label in the manner described below, with the leading edge of the postage indicium aligned with the detected leading edge of the fluorescent marking.

In addition, the fluorescent marking may be in the form of a barcode representative of information,

e.g., a backup code described below, which helps delivery of the associated mailpiece.

To generate postage indicium 400 onto label 403, a user may operate user interface 500 in Fig. 5, which is shown as it appears on cover 203 in Fig. 2A. User interface 500 includes display 503 which may be a liquid crystal display (LCD), and keypad 505. For example, display 503 may be used to exhibit the weight of a mailpiece being processed in response to the aforementioned weight signal from weighing mechanism 117, and information entered by the user using keypad 505. Such information may concern the mail class, any special services including insurance, and postage for the mailpiece being processed.

Keypad 505 comprises numeric keys for entries of numerals "0" through "9", CLEAR key 507 for erasing the last entry, ENTER key 509 for effecting an entry, ZERO key 511 for zeroing or taring the weight of holder 215 sensed by measuring device 219, SECURITY key 513 for affording password protection from unauthorized access to system 100, EXIT key 515 for exiting the current process, MENU key 517 for accessing various menus, e.g., menus pertaining to functions other than postage payment, LOAD FUND key 519 for initiating a TMS funds transfer described before, CALC key 521 for activating a calculator function, HIGH VALUE key 523 for setting a high value limit to prevent inadvertently dispensing postage above such a limit, SPECIAL SERVICE key 525 for invoking special services such as insurance, certified mail, etc., MAIL CLASS key 527 for specifying the mail class of the mailpiece being processed, and METER key 529 for initiating a postage franking routine.

One such postage franking routine, denoted 600, is illustrated in Fig. 6. Instructed by routine 600 which is stored in memory 109, processor 105 at step 603 causes display 503 of user interface 500 to exhibit the weight of the mailpiece being processed, in response to

-14-

the weight signal from weighing mechanism 117.

Alternatively, if weighing mechanism 117 is not used, the user may enter the weight measured by other mechanisms on keypad 505. At step 607, processor 105 prompts for, and
5 receives from the user, information concerning the mail class of the mailpiece. Using MAIL CLASS key 527, the user is provided with choices of mail classes which are presented one by one on display 503, and he/she may select by pressing ENTER key 509 the desired choice, say,
10 first class mail, as it appears on the display. At step 610, processor 105 prompts for, and receives from the user, information concerning any special services for the shipment. Similarly, using SPECIAL SERVICE key 525, the user is provided with choices of special services,
15 including certified mail, insurance, etc., from which the user may select. At step 613, processor 105 prompts for, and receives from the user, information concerning the zip code of the destination of the mailpiece.

At step 615, assuming in this instance that
20 system 100 does not carry postage rate information, processor 105 prompts for, and receives from the user, information concerning the required postage for mailing the mailpiece. Otherwise, if system 100 has the postage rate information available, e.g, from a rate module pre-
25 installed in system 100, an external scale, or another source, processor 105 would compute the required postage based on the postage rate information, instead. At step 617, processor 105 sends, to PSD 130, postal information to be signed for authentication purposes, including the
30 postage, destination zip code, mail class information, and other information including the software ID, device ID and PSD certificate which is pre-stored in memory 109.

Upon receiving such postal information, processor 305 in PSD 130 deducts the postage amount from
35 the available postal fund in the descending register in memory 307, and accordingly adds same to the dispensed fund in the ascending register in memory 307 to account

-15-

for the transaction. In addition, processor 305 generates a digital signature in accordance with the DSA for authenticating the received postal information, and the ascending and descending register values. At step 5 620, processor 105 receives from processor 305 the digital signature, and the ascending and descending register values. At step 623, processor 105 prepares a bit map for a print image of the 2-D barcode of machine readable portion 410 representing the required postal 10 information, which is arranged in accordance with the Uniform Symbology Specification PDF 417. At step 626, processor 105 prepares a second bit map for a print image of human readable portion 405. These bit maps are temporarily stored in a print memory space allocated in 15 memory 109. At step 629, processor 105 issues a print command to printing mechanism 115. Accordingly, the latter retrieves from the print memory space the respective bit maps, and prints postage indicium 400 onto the label stock dispensed by the dispenser in operating 20 portion 111.

Printing mechanism 115 comprising print head assembly 207 may utilize different technologies to print indicia onto the label stock. A first technology, known as "thermal transfer printing," involves use of a therm- 25 sensitive transfer ribbon or tape having selected color ink thereon. Using this technology, print head assembly 207 based on the bit map information imparts selective spot heating to one side of the ribbon to imprint a desired indicium in the color ink onto the label stock in 30 contact with the other side of the ribbon. Preferably, the transfer ink on the ribbon is not in a single color, e.g., black only, but consists of multiple color inks disposed in a selected pattern on the ribbon, thereby rendering forgery of the resulting multi-color indicium 35 difficult. The multi-color indicium may further have colored pixels scattered at random or predefined locations within the indicium to facilitate fraud

-16-

detection based on the locations of the colored pixels. Alternatively, the multi-color indicium may assume a color pattern visually undetectable, and yet detectable under forensic examination, thereby effectively
5 preventing fraud.

A second technology, known as "direct thermal printing," involves use of therm-sensitive label material. Using this technology, print head assembly 207 based on the bit map information imparts selective spot
10 heating directly onto the label material itself to realize the indicium thereon. Thus, the principal difference between the thermal transfer printing above and the direct thermal printing here is that the label material used in the latter is capable of producing a
15 color image based upon the intensity and/or duration of heat imparted by the pixel elements of print head assembly 207 to the label material. As a result, the direct thermal printing requires special label material to realize the above-described multi-color indicium. Due
20 to the need to obtain such special material, any fraudulent attempt to forge the indicium may prove to be further cost-ineffective.

A third technology is known as "inkjet printing," whereby based on the bit map information,
25 print head assembly 207 controllably squirts jets of ink which may be in different colors directly onto the label material to realize the indicium thereon. The inkjet printing can readily produce the above-described multi-color indicium for fraud prevention.

30 If the label material used in system 100 is transparent, it may be desirable to print an indicium on the reverse side of the label stock. Importantly, the indicium printed on the label stock has to be a mirror image of what is desired on the mailpiece, as when a
35 printed label is applied onto the mailpiece with the reverse side affixed to the mailpiece, the indicium would read properly through the label material. Advantageously,

-17-

the indicium is covered and sealed by the label material, thereby protecting the indicium from spoilage because of environmental conditions (e.g., moisture). In addition, once the label is affixed to the mailpiece, the indicium
5 would be significantly damaged when the affixed label is removed from the mailpiece, thereby preventing fraudulent reuse of or tampering with the indicium.

If the label material is not transparent, the indicium is printed on the obverse or facing side of the
10 material. To prevent fraudulent reuse of or tampering with the indicium, it may be desirable to use perforated or segmented label material which would splinter, and thus self-destruct, when removed from a mailpiece after the printed label is affixed thereto. Alternatively, it
15 may be desirable to use label material which would be stressed and deform when removed from a mailpiece after the printed label is affixed thereto. Once a label is deformed, the coded image, e.g., 2-D barcode of portion
410, of the indicium thereon is no longer intelligible
20 and readable by a scanner, thus rendering the indicium useless.

However, for those indicia printed on the obverse side of the label stock, they are likely exposed to water, dirt, smudge, and the like while they are in
25 transit to the postal authority. As a result, the coded image, e.g., 2-D barcode in portion 410, of the exposed indicia may have been corrupted and become unintelligible when scanned by the postal authority. Referring to Fig. 7, it may thus be desirable to include backup code 705,
30 in addition to the primary 2-D barcode (denoted 708), on label 710. Such a backup code may be less secure and contain less information than the primary code. Nonetheless, should the primary code be corrupted, the backup code can be utilized to help process the
35 associated mailpiece. As shown in Fig. 7, backup code 705 is in the form of a one-dimensional barcode which is also readable by an optical scanner. Backup code 705 is

-18-

printed and disposed far from primary code 708 on label 710 to lessen the chance that they both would be corrupted.

For example, the backup code may contain error
5 correction or detection information for correcting or
detecting errors in the primary code, in accordance with
a well known error correction and/or detection technique
for data communications, e.g., the Reed-Solomon error
10 correction technique. When the primary and backup codes
on the printed label are scanned by the postal authority,
the backup code may be used to correct errors, if any, in
the primary code, provided that the number of errors does
not exceed a predetermined limit depending on the actual
15 data error correction technique used. In the event that
there are too many errors in the primary code to be
corrected, and the errors are however detected, using the
backup code, the printed label would then be visually
inspected to determine any fraud perpetration. If both
the primary code and backup code are corrupted, and fraud
20 is suspected, the associated mailpiece would be rejected.

It should be noted that backup code 705 may be
fluorescent, constituting fluorescent marking whose
advantages have been described hereinbefore.

Alternatively, to protect an indicium printed
25 on the obverse side of a label from adverse environmental
conditions, label device 103 additionally dispenses a
transparent tape to be bonded over the indicium on the
label. Thus, the resulting label becomes a two-layer
label with the indicium sandwiched between the two
30 layers.

It should also be noted that it is particularly
advantageous to use label stock in system 100 in the form
of a continuous tape which may be self-adhesive or may
require moistening for affixing purposes. In accordance
35 with an aspect of the invention, such label stock may be
dispensed in a selected length so that the resulting
tape-label, having a franked postage indicium thereon,

may also be used to (a) seal a mailpiece, e.g., to seal over a package or an envelope flap, and/or (b) provide thereon information in addition to the required postal information. During the postage franking operation, through user interface 500, the user may specify the length of the tape-label to be dispensed by dispenser mechanism 209. The specific length depends on the size of the package if the tape is used for sealing purposes, and/or the amount of additional information to be printed thereon, which may vary from one mailpiece to another. Such additional information may concern the sender and/or the recipient of the mailpiece, and include, for example, the recipient's account number, date of packing, purchase order number, return authorization number, etc. The additional information is presented on the tape-label in a coded or uncoded format. The recipient of the mailpiece may provide via a communications network part of such additional information, e.g., purchase order number, in the form of a barcode, text and/or graphics for system 100 to print on the tape-label before shipment of the mailpiece.

As mentioned before, device 103 may act as a host device and be connected to peripherals to enhance its functionality. For example, as shown in Fig. 8, system 100 may be connected to external electronic postage scale 803 through interface 120. One such scale is described in U.S. Patent No. 5,615,120 issued March 25, 1997 to Schwartz et al. Such an external scale may replace or supplement weighing mechanism 117 built into system 100 and a principal portion of user interface 500. In addition, the external scale typically provides postage rate information, thereby rendering the computation of postage by system 100 automatic.

Moreover, as shown in Fig. 9, device 103 may also be connected to PC 903 through communications interface 125. With this configuration, the need for user interface 500 is obviated. In particular, menu options

-20-

accessible by MENU key 517 on interface 500 may be implemented on PC 903. The user may utilize a keyboard and/or a mouse attached to PC 903 to operate the menu options. Processor 105 in device 103 responds to the user's input and control commands from PC 903.

Application software may be installed in PC 903 to enhance the functionality of system 100. Such application software may include a mailer application program whereby mailing addresses can be entered on PC 903 and formatted for printing on the label stock. In accordance with another aspect of the invention, the label stock used in device 103 comprises an array of individual labels which are arranged in pairs on a backing. Fig. 10 illustrates one such label stock, denoted 1001, where, for example, individual labels 1003a and 1003b are paired and dispensed by device 103 at the same time.

Utilizing the aforementioned mailer program to print a mailing address on label stock 1001, the user enters a mailing address on PC 903 in a specified format. For example, the entry of the address is broken into multiple fields. Central processing unit (CPU) 907 in PC 903 causes the received fields containing data concerning the mailing address to be transmitted to processor 105 in label device 103. One of the fields includes a destination zip code, which is part of the mailing address. Accordingly, processor 105 receives the mailing address data fields, as indicated at step 1105 in Fig. 11. Because of the specified order of the data fields received, processor 105 readily locates the destination zip code data field and learns the destination zip code therein, as indicated at step 1107. Processor 105 then at step 1109 generates the bit map for a print image of the mailing address. At step 1111, processor 105 causes printing mechanism 115 to print on first label 1003a the mailing address which naturally includes the destination

-21-

zip code, which illustratively is "98765" in this instance.

For mailing efficiency, it is desirable to generate a postage indicium corresponding to the printed mailing address onto second label 1003b which is to be applied, together with printed address label 1003a, to the same mailpiece. To that end, mailer program 1100 incorporates the steps similar to those of postage franking routine 600 describe above, except step 613 which is no longer required, as processor 105 has learned the destination zip code from the mailing address entry. In addition, in those steps of program 1100 corresponding to steps 603, 607, 610 and 615 of routine 600, CPU 907 replaces the role of processor 105 while the keyboard, display and mouse of PC 903 replace the role of user interface 500. In any event, at step 1115, processor 105 in accordance with an aspect of the invention generates the bit map for a print image of not only the desired postage indicium (e.g., indicium 400), but also the destination zip code (i.e., "98765"). At step 1117, processor 105 causes printing mechanism 115 to print on second label 1003b both postage indicium 400 and the destination zip code denoted 1010, as shown in Fig. 10. It should be pointed out that destination zip code 1010 is printed in plain text on label 1003b, as opposed to being coded and hidden in machine readable portion 410 on label 403. Since destination zip code 1010 on label 1003b is human readable, one can easily match it up with the associated address label 1003a, including the same destination zip code, for the same mailpiece, even when the labels are not dispensed in pairs but in tandem, i.e., one by one.

In addition, shipping and tracking programs may be installed in PC 903 to take advantage of other carrier services such as FedEx, UPS, Emery, etc. The user may utilize PC 903 running such programs to establish on-line connections, through a communications network, to host

-22-

data centers of the respective services, and access information concerning shipment delivery times, pick up times, the least expensive method of shipping, etc. of the carriers. Moreover, information concerning FedEx
5 airbills, UPS facsimiles, or other documents accompanying a shipment may also be obtained via an on-line connection. Such information may be directed to label device 103 for it to generate the necessary document in the form of a label. Further, information concerning an
10 advertisement may also be obtained via the on-line connection, and directed to label device 103 for it to print the advertisement in text and/or graphics on the label.

In addition, we have recognized that label
15 device 103 may be used to generate a secure indicium other than a postage indicium onto a label. The label having such a secure indicium thereon may represent, e.g., a coupon, a notary stamp, deed stamp, etc. The information required for generating the secure indicium
20 may be downloaded from a host system issuing the indicium via a communication connection. Similar to postage indicium 400, the secure indicium may also include a human readable portion describing the nature of the indicium in plain text, and a machine readable portion
25 representing selected data which may be encrypted or unencrypted, and which may include a digital signature for authenticating the data and thus the indicium.

We have also recognized that PSD 130 in payment system 100 actually functions as a "virtual bank" or an
30 "electronic purse," as PSD 130 stores a postal fund for ready dispensation, which may be recharged or replenished via a TMS transaction described before. As such, in accordance with yet another aspect of the invention, system 100 may be used to realize a financial transaction
35 other than postage dispensation. For example, using an external modem, system 100 may establish a connection through a communications network to a server system

connected to the network. The server system may then engage in a financial transaction with system 100 through the connection. The financial transaction may involve transferring part of the postal fund stored in PSD 130, as a payment, to a secure vault (e.g., a secure non-volatile memory) in the server system, and downloading data concerning an indicium for system 100 to print the indicium on a medium, e.g., the label stock. The transaction data may be communicated pursuant to a protocol similar to the well-known protocol of the TMS transaction, with system 100 playing the role of the otherwise TMS host system, and the server system playing the role of a postage meter. The resulting, printed indicium is indicative of the payment and contains information concerning the product or service for which the payment is made, entitling the user to such a product or service.

For example, the aforementioned server system may provide a state lottery game service over a communications network. System 100 in this instance is connected to an external modem through interface 120, and programmed to provide access to the game service. To realize a lottery entry, the user at system 100 presses MENU key 517 on user interface 500 to invoke a menu, from which the user selects the routine pertaining to the lottery game service. Instructed by such a routine, processor 105 prompts for the desired numbers for the lottery entry on display 503, as indicated at step 1205 in Fig. 12. In response, the user enters selected lottery numbers using keypad 505.

At step 1207, processor 105 stores the received lottery numbers in memory 109. At step 1210, processor 105 causes processor 305 in PSD 130 to deduct an amount from the descending register value for payment of the lottery entry, and increment the ascending register value by the same amount to account for this transaction. At step 1213, processor 105 prompts for, and receives from

-24-

the user, a personal identification number (PIN) for reasons set forth below. At step 1215, processor 105 uses the external modem to establish a connection with the server system through the communications network. At
5 step 1220, processor 105 causes transaction data concerning the stored lottery numbers, payment and PIN to be transmitted to the server system via the established connection. Such transaction data may be signed and certified by a certificate authority to ensure its
10 authenticity and non-repudiation, and/or encrypted for security purposes.

Upon receiving the transaction data, the server system increases the fund stored in its secure vault by the payment amount. It should be noted that such a vault
15 may be designed according to the PSD requirements by the postal authority and, like a PSD, it may comprise a descending register and an ascending register. The fund recorded in the vault may be audited by the postal authority, and may be redeemed for cash. The server
20 system encrypts the received PIN using a well known encryption algorithm, and then transmits data concerning an indicium including the encrypted PIN to system 100. At step 1223, processor 105 causes printing mechanism 115 to print the indicium on the label stock based on the
25 received data. The resulting printed label is indicative of the payment for the lottery entry and contains information regarding the entry, entitling the user to redeem a prize if he/she wins the lottery.

Fig. 13 illustrates one such printed label
30 (denoted 1303) serving as a lottery ticket resulting from the above transaction. As shown in Fig. 13, like indicium 400 on label 403, indicium 1300 on label 1303 includes human readable portion 1305, and machine readable portion 1310. For example, human readable
35 portion 1305 may include information in plain text concerning the selected numbers for the lottery entry, date of entry, ticket price, transaction number, etc.

-25-

Machine readable portion 1310 may include a 2-dimensional PDF 417 barcode representing, in addition to the information similar to the human readable information, the encrypted PIN, a public key, and a digital signature
5 for authenticating the barcode data, in accordance with a well known public key algorithm, e.g., the aforementioned DSA.

In the event that label 1303 is a winning ticket and presented before the lottery authority to
10 claim the corresponding prize, the lottery authority may verify the digital signature using the public key to authenticate the barcode data, and thus label 1303, in accordance with the public key algorithm. It should be pointed out that once the prize is claimed, the digital
15 signature which is unique to label 1303 would be canceled. That is, a copy of label 1303 which may be created by fraudulent duplication would be useless. However, to prevent fraud where a perpetrator attempts to claim a prize using a fraudulent copy of label 1303
20 before the rightful owner of the original label, or using the original label which has been stolen or lost, the holder of the label, or a copy thereof, needs to provide the lottery authority with the PIN, which he/she is supposed to have entered during the lottery entry
25 transaction, when the label is first presented for a prize. At the same time, the lottery authority reads the encrypted PIN from machine readable portion 1310 of the presented label, and decrypts same using the corresponding decryption algorithm. The resulting PIN is
30 checked against the PIN provided by the label holder. If the two PINs match each other, it is determined that the label holder is the legitimate winner.

The foregoing merely illustrates the principles of the invention. It will thus be appreciated that those
35 skilled in the art will be able to devise various modifications or alterations which, although different

from the exemplary embodiments described herein, are within the scope as defined by the appended claims.

For example, in the disclosed embodiment, machine readable portions 410 and 1310 each
5 illustratively comprise a 2-D PDF 417 barcode representing information. However, it will be appreciated that other barcodes such as one-dimensional barcodes; symbols such as data matrix symbols in
10 accordance with the "International Symbology Specification - Data Matrix," AIM International Technical Specification, AIM International, Inc., 1996; segmenting image presentations; or stacked codes may be used to represent the same information, instead.

In addition, it will be appreciated that the
15 disclosed methodology for conducting a financial transaction, e.g., entering a lottery game, using a postal fund will have many other applications, including purchasing game tickets, theater tickets, gift certificates, money orders, etc. and conducting any other
20 transactions involving a document serving as proof of payment or prepayment.

Moreover, in the disclosed embodiment, during the financial transaction, a PIN is provided by the person conducting the transaction for later verification
25 of his/her identity. It will be appreciated that for identification purposes, the person may provide personal data concerning his/her biometrics, e.g., his/her retinal pattern, DNA composition, fingerprints, etc., instead of the PIN.

30 Finally, the illustrative embodiment of the invention is disclosed herein in a form in which the various data processing functions are performed by discrete functional blocks. These functional blocks may be implemented in various ways and combinations using
35 logic circuitry and/or appropriately programmed processors, as will be known to those skilled in the art.

-27-

Claims

1. A label device comprising:
 - a housing for accommodating at least a roll of label stock;
 - 5 a dispenser mechanism for dispensing the roll of label stock;
 - an interface for communicating data concerning an amount of a payment of postage to an accounting unit external to the label device to reduce a fund stored in
 - 10 the accounting unit by a second amount, the second amount being a function of the amount of the payment of postage;
 - a processor for generating signals representative of at least an image of a postage indicium indicative of the payment of postage; and
 - 15 a printing mechanism responsive to the signals for printing at least the image of the postage indicium on the roll of label stock.
2. The device of claim 1 wherein the second amount being the same as the amount of the payment.
- 20 3. The device of claim 1 further comprising a weighing apparatus, wherein the housing also accommodates the weighing apparatus.
4. The device of claim 1 wherein the roll of label stock is in a continuous tape form.
- 25 5. The device of claim 1 wherein the roll of label stock is self-adhesive.
6. The device of claim 1 wherein the roll of label stock is dispensed at a selected length.
7. The device of claim 6 wherein the selected
- 30 length is a function of the size of a mailpiece onto

which the printed image of the postage indicium is applied.

8. The device of claim 6 wherein at least one selected image other than the image of the postage
5 indicium is printed on the roll of label stock, the selected length being a function of the size of the selected image.

9. The device of claim 8 wherein the selected image contains address information.

10 10. The device of claim 1 wherein the label stock is transparent and has a selected side thereof for adhering to a mailpiece, the image of the postage indicium being printed on the selected side.

15 11. The device of claim 1 wherein the image of the postage indicium contains a plurality of elements, at least two of the elements having different colors.

12. The device of claim 1 wherein the label stock comprises material which disintegrates under stress.

20 13. The device of claim 12 wherein the material includes at least one perforation.

14. The device of claim 1 wherein the label stock comprises material which deforms under stress.

25 15. A payment system for conducting a transaction with a server, the transaction involving a transaction amount, the system comprising:

an accounting unit for storing a postal fund for paying at least postage, the postal fund being deducted by the transaction amount;

-29-

an interface for establishing a communications connection;

a processor for communicating, to the server, first data concerning at least the transaction amount
5 through the communications connection, and for receiving, from the server, second data concerning an indicium; and

a mechanism for presenting the indicium on a medium based on the received data.

16. The system of claim 15 wherein the
10 indicium is indicative of at least the transaction amount.

17. The system of claim 15 wherein the medium comprises label stock.

18. The system of claim 15 wherein the
15 indicium comprises a machine readable portion.

19. The system of claim 18 wherein the machine readable portion includes a barcode.

20. The system of claim 19 wherein the barcode is a 2-dimensional barcode.

20 21. The system of claim 18 wherein the machine readable portion contains information concerning a personal identification number (PIN).

22. The system of claim 21 wherein the PIN is encrypted.

25 23. The system of claim 18 wherein the machine readable portion contains information concerning biometrics.

24. The system of claim 18 wherein the machine readable portion contains information concerning a digital signature.

25. The system of claim 15 wherein the
5 transaction concerns a lottery entry.

26. The system of claim 15 wherein the accounting unit comprises a postal security device (PSD).

27. The system of claim 15 wherein the accounting unit includes a register for recording an
10 available amount of the postal fund.

28. The system of claim 15 wherein the accounting unit includes a register for recording a dispensed amount of the postal fund.

29. Apparatus for generating a postage
15 indicium indicative of a payment of postage, the apparatus comprising:
a print head assembly responsive to at least one signal for printing the postage indicium; and
potting material for encapsulating at least
20 part of the apparatus including a connection transporting the signal to the print head assembly, the potting material being thermoconductive to help dissipate heat from the encapsulated part.

30. The apparatus of claim 29 wherein the
25 potting material includes epoxy.

31. Apparatus for generating a postage indicium indicative of a payment of postage, the apparatus comprising:
a print head assembly responsive to at least
30 one signal for printing the postage indicium; and

-31-

a sensor for detecting an intrusion on a connection transporting the signal to the print head assembly, at least part of the sensor and the connection being encapsulated in potting material.

5 32. The apparatus of claim 31 wherein the sensor includes a carrier for transporting a second signal, the carrier being arranged in proximity to the connection.

10 33. The apparatus of claim 32 wherein the second signal is an electrical signal and the carrier includes a conductor.

 34. The apparatus of claim 32 wherein the second signal is an optical signal and the carrier includes an optical fiber.

15 35. The apparatus of claim 31 wherein the sensor comprises a control for affecting operation of the apparatus.

 36. The apparatus of claim 31 wherein the potting material includes epoxy.

20 37. Apparatus for generating a postage indicium, the apparatus comprising:
 a dispenser mechanism for providing a medium, fluorescent marking being printed on the medium; and
 a printing mechanism for printing the postage
25 indicium on the medium, the printed postage indicium being non-fluorescent.

 38. The apparatus of claim 37 wherein the medium comprises label stock.

-32-

39. The apparatus of claim 37 wherein the printing mechanism prints both of the fluorescent marking and the postage indicium on the medium.

40. The apparatus of claim 37 wherein the
5 fluorescent marking is printed before the postage indicium.

41. The apparatus of claim 37 wherein the fluorescent marking is in the form of a stripe.

42. The apparatus of claim 37 wherein the
10 fluorescent marking is in the form of a barcode representative of information.

43. The apparatus of claim 37 wherein the printed postage indicium is positioned on the medium according to a position of the fluorescent marking.

15 44. The apparatus of claim 37 wherein the fluorescent marking is invisible.

45. Apparatus for providing a postage indicium indicative of a payment of postage, the apparatus comprising:

20 a processor for generating the postage indicium, which includes a first machine readable portion and a second machine readable portion, the first machine readable portion being separate from the second machine readable portion, the first machine readable portion
25 representing postal data, the second machine readable portion representing second data for recovering at least part of the postal data when the first machine readable portion is corrupted; and

30 a mechanism for setting the postage indicium on a medium.

46. The apparatus of claim 45 wherein the second data includes the at least part of the postal data.

5 47. The apparatus of claim 45 wherein the second data includes a code for correcting at least one error in the postal data.

48. The apparatus of claim 45 wherein the second data includes a code for detecting at least one error in the postal data.

10 49. The apparatus of claim 45 wherein the first machine readable portion includes a barcode.

50. The apparatus of claim 49 wherein the barcode is a two-dimensional barcode.

15 51. The apparatus of claim 45 wherein the second machine readable portion includes a barcode.

52. The apparatus of claim 51 wherein the barcode is a one-dimensional barcode.

53. Apparatus for dispensing label stock, the apparatus comprising:

20 a mechanism for setting an address on a first part of the label stock and a postage indicium on a second part of the label stock, the postage indicium being indicative of a payment of postage, the first part and the second part being applied onto a mailpiece; and
25 a processor for generating at least one indication for associating the first part with the second part, the indication being set on at least one of the first and second parts.

-34-

54. The apparatus of claim 53 wherein the indication is human readable.

55. The apparatus of claim 53 wherein the indication is set onto the second part, and the
5 indication contains information concerning at least part of the address.

56. The apparatus of claim 55 wherein the information concerns a zip code in the address.

57. A method for use in a label device having
10 a housing for accommodating at least a roll of label stock, the method comprising:

communicating data concerning an amount of a payment of postage to an accounting unit external to the label device to reduce a fund stored in the accounting
15 unit by a second amount, the second amount being a function of the amount of the payment of postage;

generating signals representative of at least an image of a postage indicium indicative of the payment of postage;
20 dispensing the roll of label stock; and
printing at least the image of the postage indicium on the roll of label stock in response to the signals.

58. The method of claim 57 wherein the second
25 amount being the same as the amount of the payment.

59. The method of claim 57 further comprising determining a weight of a mailpiece onto which the printed image of the postage indicium is applied.

60. The method of claim 59 further comprising
30 determining the amount of the payment of postage based on at least the weight of the mailpiece.

61. The method of claim 57 wherein the roll of label stock is dispensed at a selected length.

62. The method of claim 61 wherein the selected length is a function of the size of a mailpiece onto which the printed image of the postage indicium is applied.

63. The method of claim 61 wherein at least one selected image other than the image of the postage indicium is printed on the roll of label stock, the selected length being a function of the size of the selected image.

64. The method of claim 63 wherein the selected image contains address information.

65. The method of claim 57 wherein the label stock is transparent and has a selected side thereof for adhering to a mailpiece, the image of the postage indicium being printed on the selected side.

66. The method of claim 57 wherein the image of the postage indicium contains a plurality of elements, at least two of the elements having different colors.

67. A method for conducting a transaction with a server, the transaction involving a transaction amount, the method comprising:

storing a postal fund for paying at least postage, the postal fund being deducted by the transaction amount;

establishing a communications connection; communicating, to the server, first data concerning at least the transaction amount through the communications connection;

-36-

receiving, from the server, second data concerning an indicium; and presenting the indicium on a medium based on the received data.

5 68. The method of claim 67 wherein the indicium is indicative of at least the transaction amount.

69. The method of claim 67 wherein the indicium includes a machine readable portion.

10 70. The method of claim 69 wherein the machine readable portion includes a barcode.

71. The method of claim 70 wherein the barcode is a 2-dimensional barcode.

15 72. The method of claim 69 wherein the machine readable portion contains information concerning a PIN.

73. The method of claim 72 wherein the PIN is encrypted.

20 74. The method of claim 69 wherein the machine readable portion contains information concerning biometrics.

75. The method of claim 69 wherein the machine readable portion contains information concerning a digital signature.

25 76. The method of claim 67 wherein the transaction concerns a lottery entry.

77. The method of claim 67 further comprising recording an available amount of the postal fund.

78. The method of claim 67 further comprising recording a dispensed amount of the postal fund.

79. A method for use in an apparatus including a print head assembly responsive to at least one signal
5 for printing a postage indicium indicative of a payment of postage, the method comprising:

disposing a sensor in proximity to a connection transporting the signal to the print head assembly;
encapsulating at least part of the sensor and
10 the connection using potting material; and
detecting any intrusion on the connection using the sensor.

80. The method of claim 79 further comprising affecting operation of the apparatus upon detecting the
15 intrusion.

81. A method for use in an apparatus for generating a postage indicium, the method comprising:
providing a medium, fluorescent marking being printed on the medium; and
20 printing the postage indicium on the medium, the printed postage indicium being non-fluorescent.

82. The method of claim 81 wherein the fluorescent marking is printed along with the postage indicium.

25 83. The method of claim 81 wherein the fluorescent marking is printed before the postage indicium.

84. The method of claim 81 wherein the fluorescent marking is in the form of a stripe.

85. The method of claim 81 wherein the fluorescent marking is in the form of a barcode representative of information.

86. The method of claim 81 further comprising
5 positioning the printed postage indicium on the medium according to a position of the fluorescent marking.

87. The method of claim 81 wherein the fluorescent marking is invisible.

88. A method for providing a postage indicium
10 indicative of a payment of postage, the method comprising:

generating the postage indicium, which includes a first machine readable portion and a second machine readable portion, the first machine readable portion
15 being separate from the second machine readable portion, the first machine readable portion representing postal data, the second machine readable portion representing second data for recovering at least part of the postal data when the first machine readable portion is
20 corrupted; and

setting the postage indicium on a medium.

89. The method of claim 88 wherein the second data includes the at least part of the postal data.

90. The method of claim 88 wherein the second
25 data includes a code for correcting at least one error in the postal data.

91. The method of claim 88 wherein the second data includes a code for detecting at least one error in the postal data.

92. The method of claim 88 wherein the first machine readable portion includes a barcode.

93. The method of claim 92 wherein the barcode is a two-dimensional barcode.

5 94. The method of claim 88 wherein the second machine readable portion includes a barcode.

95. The method of claim 94 wherein the barcode is a one-dimensional barcode.

10 96. A method for use in an apparatus for dispensing label stock, the method comprising:
 setting an address on a first part of the label stock and a postage indicium on a second part of the label stock, the postage indicium being indicative of a payment of postage, the first part and the second part
15 being applied onto a mailpiece;
 generating at least one indication for associating the first part with the second part; and
 setting the indication on at least one of the first and second parts.

20 97. The method of claim 96 wherein the indication is human readable.

98. The method of claim 96 wherein the indication is set on the second part, and the indication contains information concerning at least part of the
25 address.

99. The method of claim 98 wherein the information concerns a zip code in the address.

FIG. 1

100

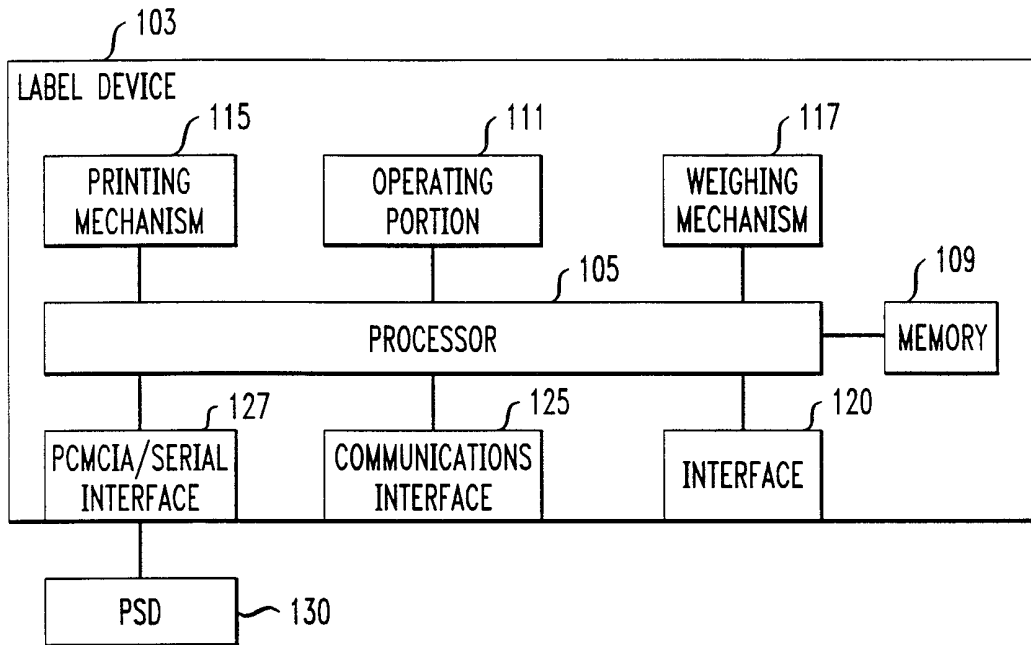

FIG. 2A

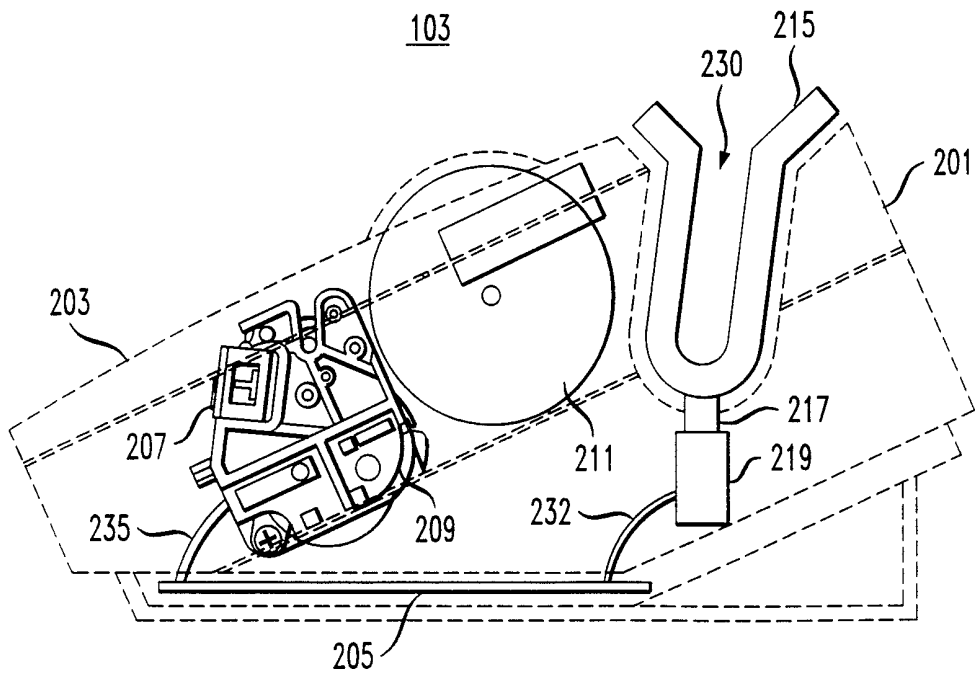

FIG. 2B

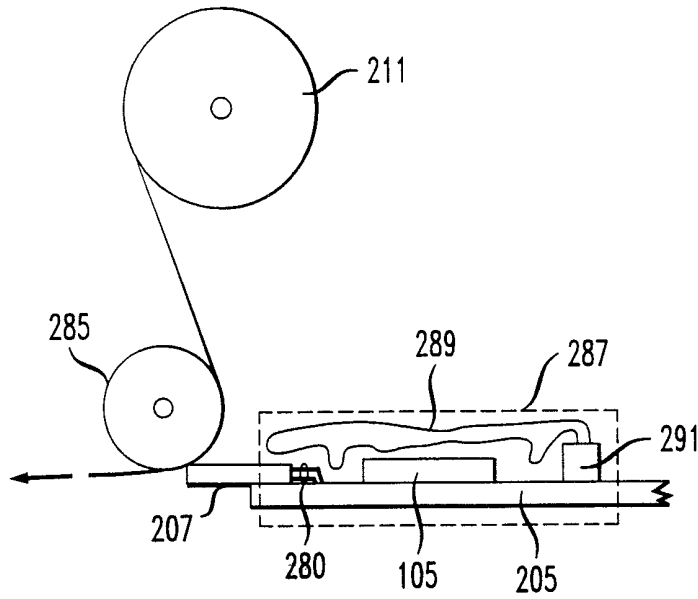
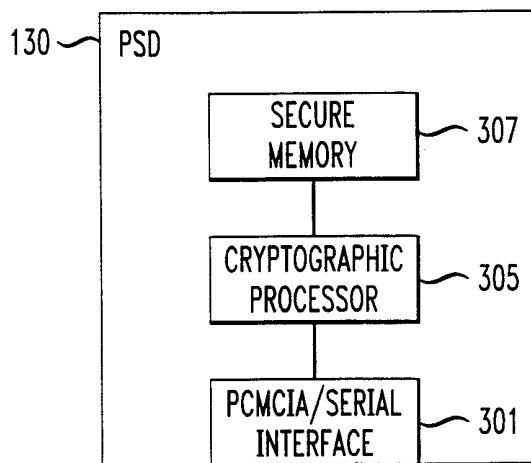

FIG. 3



3/7

FIG. 4

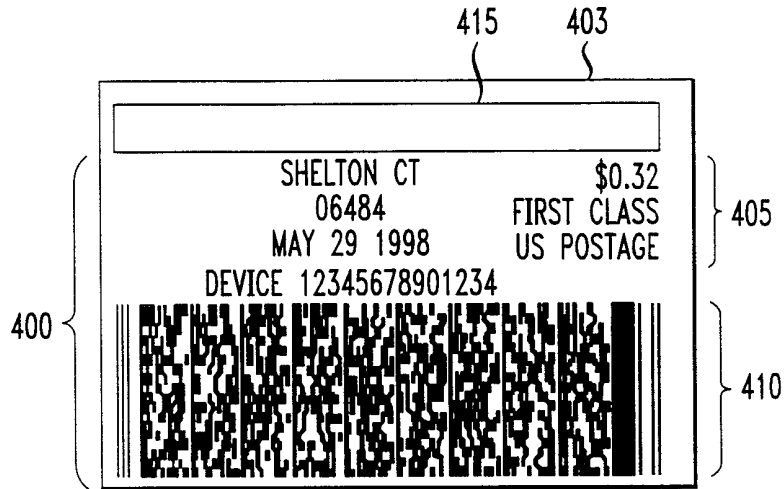

FIG. 5

500

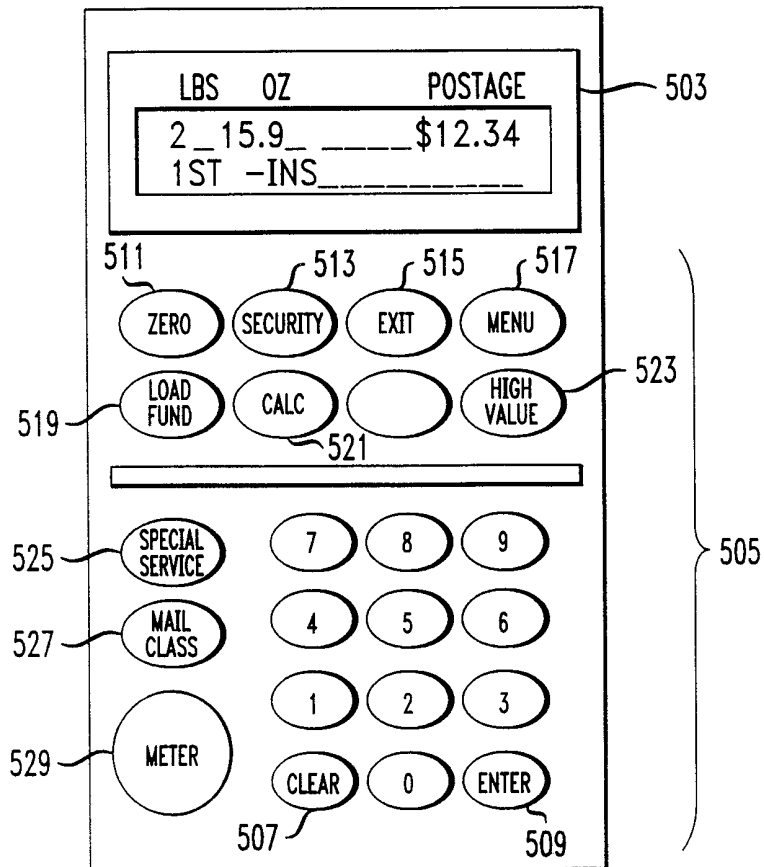

FIG. 6

600

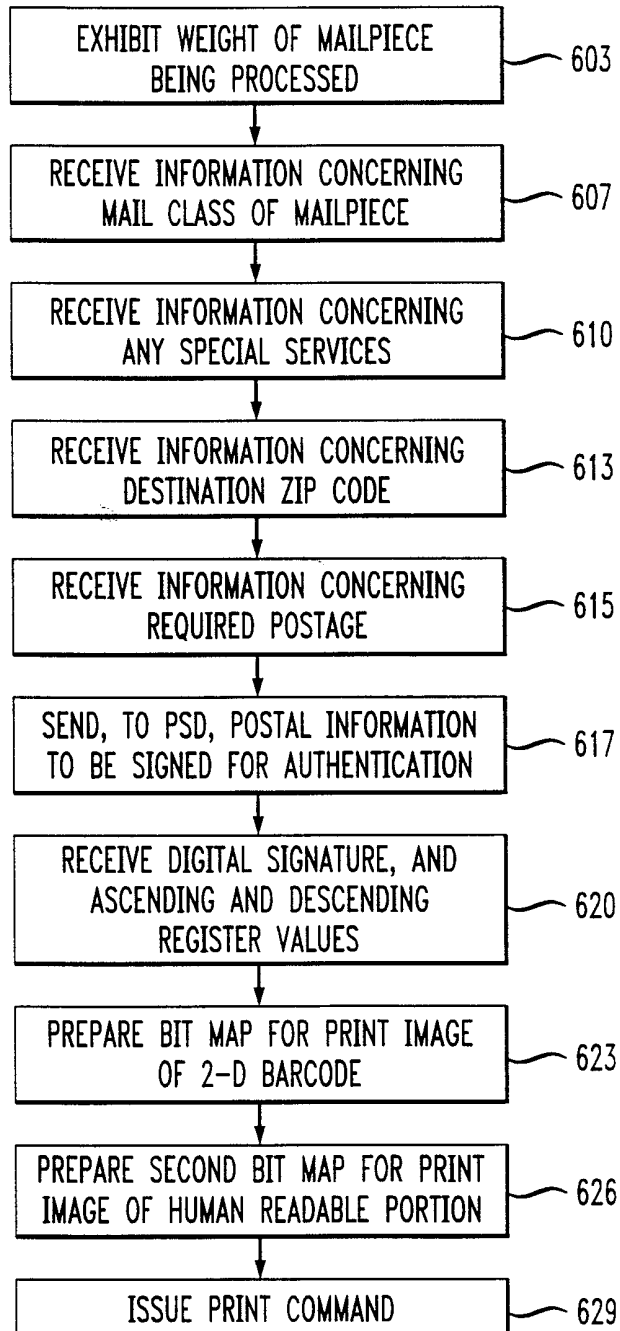

FIG. 7

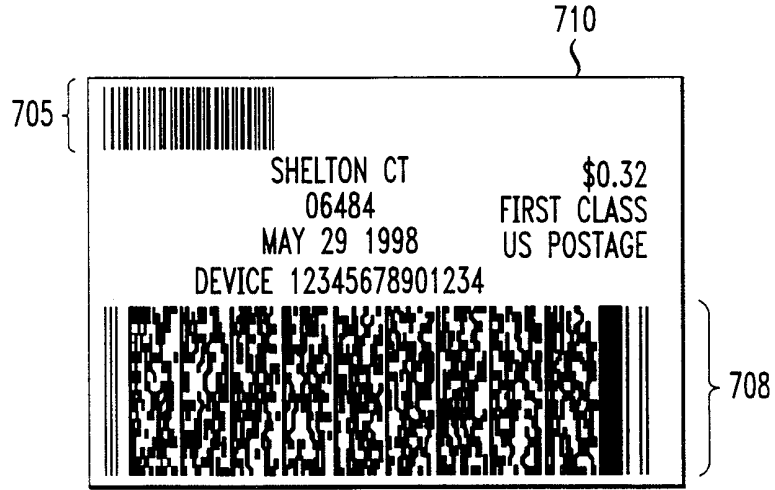

FIG. 8

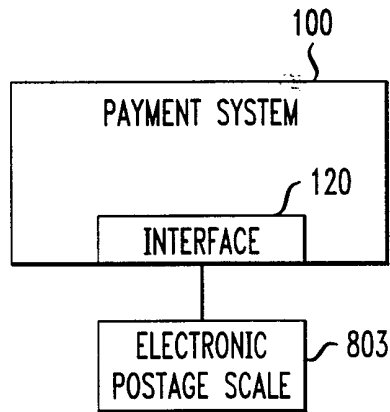

FIG. 9

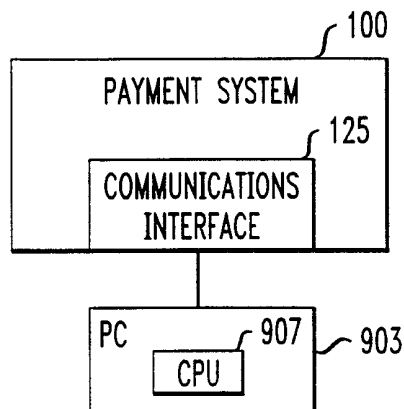

FIG. 10

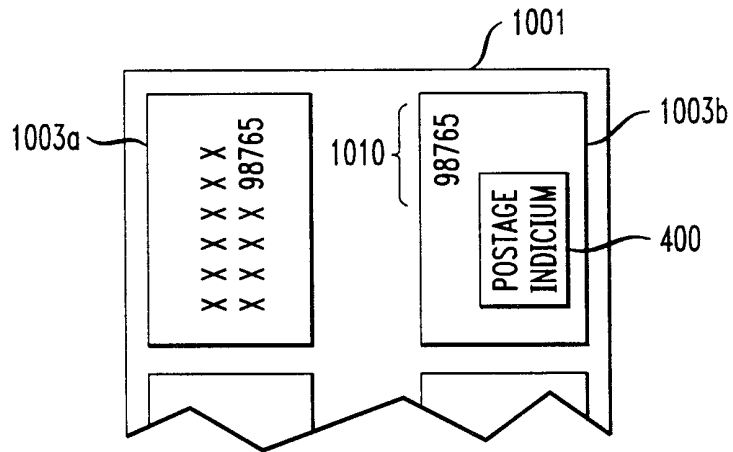

FIG. 11

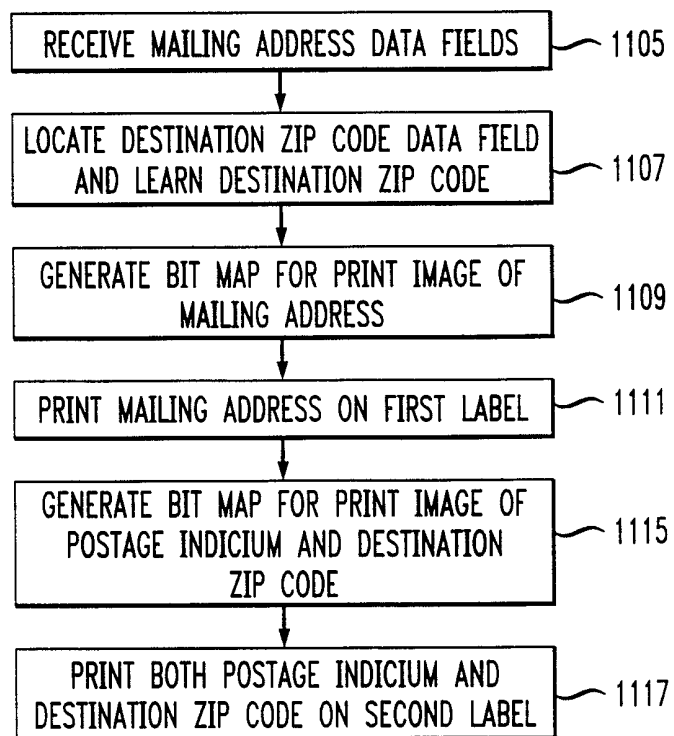

FIG. 12

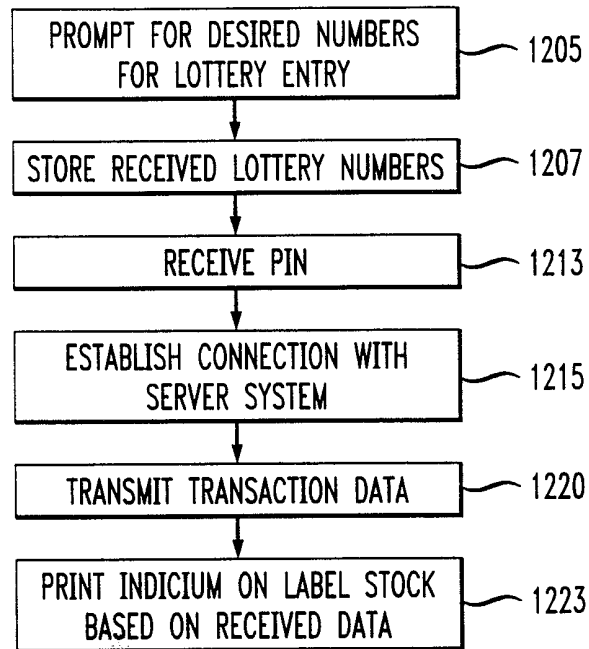
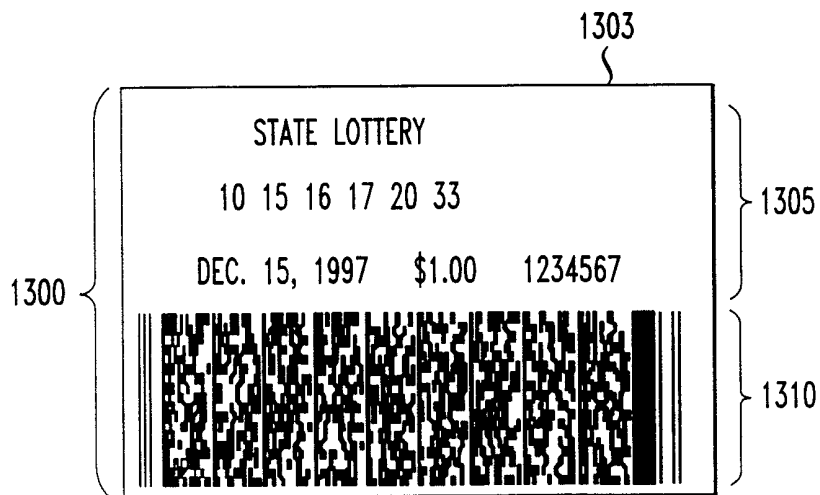

FIG. 13



INTERNATIONAL SEARCH REPORT

International application No.
PCT/US98/23097

A. CLASSIFICATION OF SUBJECT MATTER

IPC(6) : G07B 17/00; G07B 17/04

US CL : 705/408; 283/71; 380/51

According to International Patent Classification (IPC) or to both national classification and IPC

B. FIELDS SEARCHED

Minimum documentation searched (classification system followed by classification symbols)

U.S. : 283/71, 72; 380/51; 705/400, 401, 408

Documentation searched other than minimum documentation to the extent that such documents are included in the fields searched

NONE

Electronic data base consulted during the international search (name of data base and, where practicable, search terms used)

NONE

C. DOCUMENTS CONSIDERED TO BE RELEVANT

Category*	Citation of document, with indication, where appropriate, of the relevant passages	Relevant to claim No.
Y	US 4,580,144 A (CALVI) 01 April 1986, see abstract.	1-7, 10, 11, 15-22, 24-38, 40-62, 65-73, 75-81 & 83-99
Y	US 4,673,303 A (SANSONE et al) 16 June 1987, see abstract.	1-7, 10, 11, 15-22, 24-38, 40-62, 65-73, 76-81 & 83-99
Y	US 4,813,912 A (CHICKNEAS et al) 21 May 1989, see abstract.	1-7, 10, 11, 15-22, 24-38, 40-62, 65-73, 75-81 & 83-99



Further documents are listed in the continuation of Box C.



See patent family annex.

* Special categories of cited documents:

A document defining the general state of the art which is not considered to be of particular relevance

E earlier document published on or after the international filing date

L document which may throw doubts on priority claim(s) or which is cited to establish the publication date of another citation or other special reason (as specified)

O document referring to an oral disclosure, use, exhibition or other means

P document published prior to the international filing date but later than the priority date claimed

T

later document published after the international filing date or priority date and not in conflict with the application but cited to understand the principle or theory underlying the invention

X

document of particular relevance; the claimed invention cannot be considered novel or cannot be considered to involve an inventive step when the document is taken alone

Y

document of particular relevance; the claimed invention cannot be considered to involve an inventive step when the document is combined with one or more other such documents, such combination being obvious to a person skilled in the art

&

document member of the same patent family

Date of the actual completion of the international search

16 JANUARY 1999

Date of mailing of the international search report

06 MAY 1999

Name and mailing address of the ISA/US
Commissioner of Patents and Trademarks
Box PCT
Washington, D.C. 20231

Facsimile No. (703) 305-3230

Authorized officer

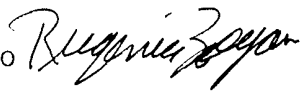
EDWARD R. COSIMANO 

Telephone No. (703)-305-9783

INTERNATIONAL SEARCH REPORT

International application No.
PCT/US98/23097

C (Continuation). DOCUMENTS CONSIDERED TO BE RELEVANT		
Category*	Citation of document, with indication, where appropriate, of the relevant passages	Relevant to claim No.
Y	US 5,122,967 A (GILHAM) 16 June 1992, see abstract.	1-7, 10, 11, 15-22, 24-38, 40-62, 65-73, 75-81 & 83-99
Y	US 5,200,903 A (GILHAM) 06 April 1993, see abstract.	1-7, 10, 11, 15-22, 24-38, 40-62, 65-73, 75-81 & 83-99
Y	US 5,408,416 A (GILHAM) 18 April 1995, see abstract.	1-7, 10, 11, 15-22, 24-38, 40-62, 65-73, 75-81 & 83-99
Y	US 5,508,933 A (ABUMEHDI) 16 April 1996, see abstract.	1-7, 10, 11, 15-22, 24-38, 40-62, 65-73, 75-81 & 83-99
Y	US 5,583,779 A (NACLERIO et al) 10 December 1996, see abstract.	1-7, 10, 11, 15-22, 24-38, 40-62, 65-73, 75-81 & 83-99
Y	US 5,680,463 A (WINDEL et al) 21 October 1997, see abstract.	1-7, 10, 11, 15-22, 24-38, 40-62, 65-73, 75-81 & 83-99
Y	US 5,712,916 A (WINDEL et al) 27 January 1998, see abstract.	1-7, 10, 11, 15-22, 24-38, 40-62, 65-73, 75-81 & 83-99
Y	US 5,734,723 A (WINDEL et al) 31 March 1998, see abstract.	1-7, 10, 11, 15-22, 24-38, 40-62, 65-73, 75-81 & 83-99
Y, E	US 5,848,401 A (GOLDBERG et al) 08 December 1998, see abstract.	1-7, 10, 11, 15-22, 24-38, 40-62, 65-73, 75-81 & 83-99

INTERNATIONAL SEARCH REPORT

International application No.
PCT/US98/23097

Box I Observations where certain claims were found unsearchable (Continuation of item 1 of first sheet)

This international report has not been established in respect of certain claims under Article 17(2)(a) for the following reasons:

1. Claims Nos. : ,
because they relate to subject matter not required to be searched by this Authority, namely:

2. Claims Nos. : 8, 9, 12, 13, 14, 23, 39, 63, 64, 74 & 82
because they relate to parts of the international application that do not comply with the prescribed requirements to such an extent that no meaningful international search can be carried out, specifically:

Please See Extra Sheet.

3. Claims Nos. :
because they are dependent claims and are not drafted in accordance with the second and third sentences of Rule 6.4(a).

Box II Observations where unity of invention is lacking (Continuation of item 2 of first sheet)

This International Searching Authority found multiple inventions in this international application, as follows:

1. As all required additional search fees were timely paid by the applicant, this international search report covers all searchable claims.
2. As all searchable claims could be searched without effort justifying an additional fee, this Authority did not invite payment of any additional fee.
3. As only some of the required additional search fees were timely paid by the applicant, this international search report covers only those claims for which fees were paid, specifically claims Nos.:

4. No required additional search fees were timely paid by the applicant. Consequently, this international search report is restricted to the invention first mentioned in the claims; it is covered by claims Nos.:

Remark on Protest

- The additional search fees were accompanied by the applicant's protest.
 No protest accompanied the payment of additional search fees.

INTERNATIONAL SEARCH REPORT

International application No.
PCT/US98/23097

BOX I. OBSERVATIONS WHERE CLAIMS WERE FOUND UNSEARCHABLE

2. Where no meaningful search could be carried out, specifically:

1.1 In regard to claims 8 & 63, the ability of selecting a second image to be printed with the postage indicium by the user lacks support with in the disclosure. Claim 9 which depends from claim 8 is included since it depends from claim 8. Claim 64 which depends from claim 63 is included since it depends from claim 63.

1.2 In regard to claims 12 & 14, the use of a label which either (A) disintegrates under stress (claim 12) or (B) deforms under stress (claim 14) lacks support with in the disclosure. Claim 13 which depends from claim 12 is included since it depends from claim 12.

1.3 In regard to claims 23 & 74, the use of "information concerning biometrics" in the indicium lacks support with in the disclosure.

1.4 In regard to claim 39, since the disclosure is directed to a system which uses preprinted labels, where the preprinted label include flourescent marking (note claim 37, lines 3-4), the printing of a flourescent marking on the medium lacks support with in the disclosure.

1.5 In regard to claim 82, since the disclosure is directed to a system which uses preprinted labels, where the preprinted label include flourescent marking (note claim 81, lines 3-4), the printing of a flourescent marking on the medium lacks support with in the disclosure.