

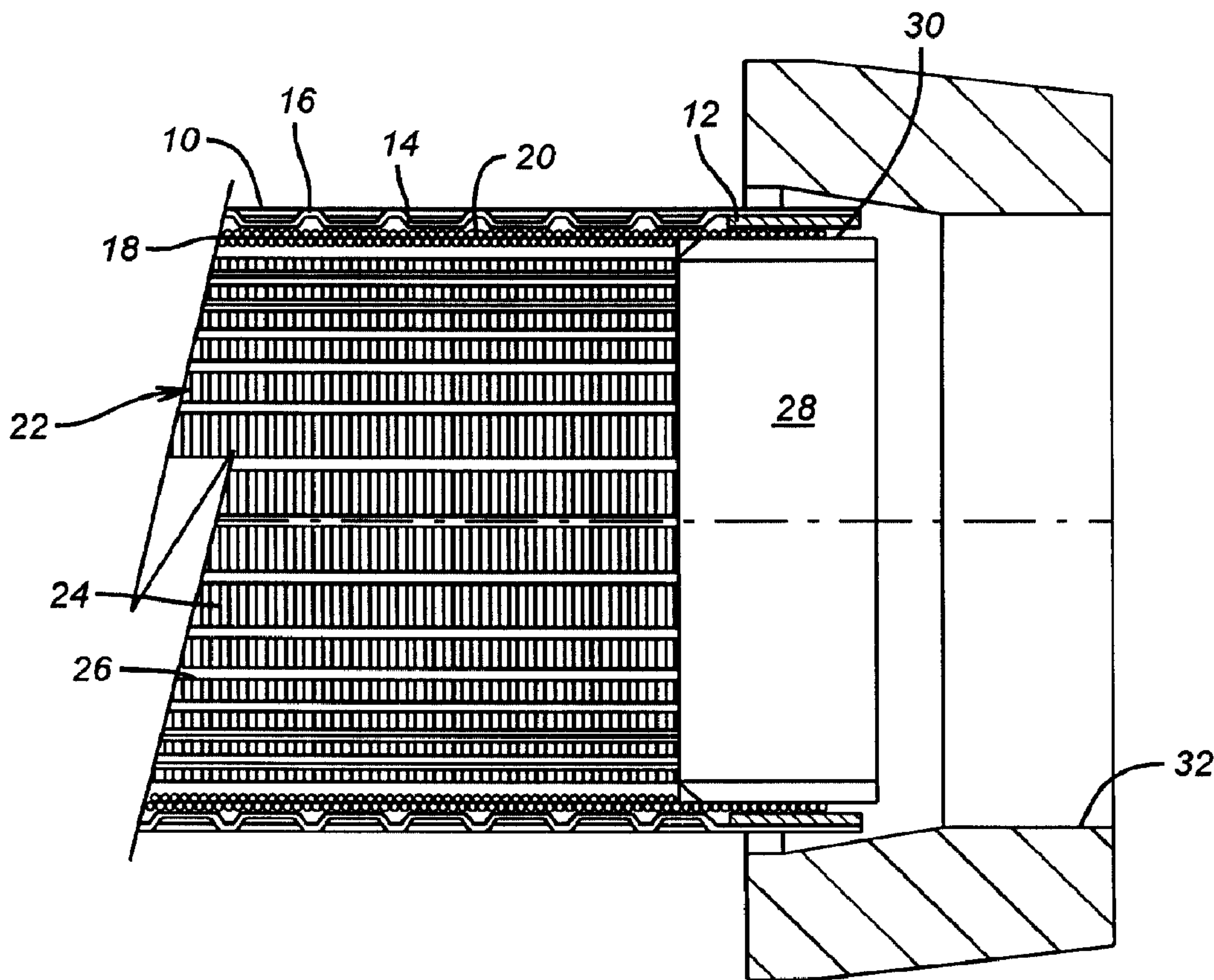

(22) Date de dépôt/Filing Date: 2000/05/26
 (41) Mise à la disp. pub./Open to Public Insp.: 2000/11/28
 (45) Date de délivrance/Issue Date: 2007/02/06
 (30) Priorité/Priority: 1999/05/28 (US09/322,099)

(51) Cl.Int./Int.Cl. *E21B 43/08* (2006.01)
 (72) Inventeurs/Inventors:
 VOLL, BENN A., US;
 BROOME, JOHN T., US;
 CORBETT, THOMAS G., US;
 GOODSON, JIM, US;
 YUAN, YUSHENG, US;
 PETERSON, ELMER R., US
 (73) Propriétaire/Owner:
 BAKER HUGHES INCORPORATED, US
 (74) Agent: SIM & MCBURNEY

(54) Titre : CRIBLE DE FOND DE TROU ET SA METHODE DE FABRICATION
 (54) Title: DOWNHOLE SCREEN AND METHOD OF MANUFACTURE



(57) Abrégé/Abstract:

A method and apparatus for manufacturing any given length of a completion filter assembly is described. An outer perforated jacket is assembled over the filter media, which is itself placed over a coarse support screen or drainage layer. In the preferred

(57) Abrégé(suite)/Abstract(continued):

embodiment, the drainage layer and outer jacket have end rings such that when advanced through a die are pushed together with the filter media in between to effect a seal of the subassembly. The subassembly can then be placed on a support pipe which is perforated, and if metallic, the end rings are welded to the support pipe to complete the assembly. Optionally, many of the components can be made of materials which lend buoyancy to the assembly so that when it is advanced into a long lateral, it will float to assist in its proper positioning.

5

ABSTRACT OF THE INVENTION

A method and apparatus for manufacturing any given length of a completion filter assembly is described. An outer perforated jacket is assembled over the filter media, which is itself placed over a coarse support screen or drainage layer. In the preferred embodiment, the drainage layer and outer jacket have end rings such that when advanced through a die are pushed together with the filter media in between to effect a seal of the subassembly. The subassembly can then be placed on a support pipe which is perforated, and if metallic, the end rings are welded to the support pipe to complete the assembly. Optionally, many of the components can be made of materials which lend buoyancy to the assembly so that when it is advanced into a long lateral, it will float to assist in its proper positioning.

5

DOWNHOLE SCREEN AND METHOD OF MANUFACTURE

FIELD OF THE INVENTION

The field of this invention relates to screen assemblies for downhole completions, particularly to control production of sand.

10

BACKGROUND OF THE INVENTION

In the past, there has been a need to control sand or other solids produced from the formation with the flowing oil or other hydrocarbons. Techniques for sand control have involved the use of screens. Various configurations have been attempted for sand-control screens.

15

These screens have generally involved a rigid base pipe which is perforated, overlaid by one or more layers of screen of different opening sizes. Generally, the finest screen, which is the one that is designed for catching the sand or other solid material, is a screen most prone to not only plugging but also other mechanical ailments.

20

In the past, these fine filtering screens have used very thin wire wrapped around the base pipe and an underlying coarser screen. The filtering screen has generally in the past had a welded longitudinal seam which failed generally due to erosive effects of the flow through the screen or chemical attack on the weldment. Sealing off the ends of the filtering screen to the underlying support structure has also been problematic. Again, due to the fine wire size of the filtering screen, welding the ends to a support body has resulted in failures due to differential expansion creating tensile loads on welds involving fine wire components of the filtering screen.

25

Various mechanical efforts to seal the filtering screen to the underlying structure, such as by use of mechanical bands, has also failed to provide a tight seal, thereby allowing the hydrocarbons to short circuit around the filtering screen, carrying the undesirable sand with them.

30

In the past, underlying coarse screens below the sand-filtering screen have been made with a wound wire having a triangular cross-section, with a flat side oriented outwardly. This has resulted in coarse screens with fairly small open areas and created numerous dead spots behind the filtering screen where the flat side of the triangularly cross-section wound wire of the underlying coarser screen butted up against the openings of the finer sand-filtering screen. As a

result, the sand-filtering screen suffered from losses of efficiency due to the numerous dead spots encountered by the outer flat side of the wound coarse screen broadly abutting the sand-filtering screen.

5 U.S. Patent 5,611,399 provides a finished assembly that does not suffer from welded attachments to thin members, which had in the past been a weak point in resisting stress, particularly due to tensile loading, flow erosion, as well as chemical attack. It also creates an efficient sand-control screen assembly by employing a substrate of a coarse screen, having wound wires of a more rounded or arcuate cross-section, to reduce the dead zones in between the filtering screen and the underlying coarse screen. It also provides a simple mechanical technique for
10 assembling the elements of the screen.

U.S. patent 5,611,399 illustrates a sand-filtering screen-making technique which involves an initial assembly of the sand-filtering screen over an underlying coarse screen. The sand-filtering screen has a mechanical longitudinal fold and overlap-type joint. End caps are fitted over the filtering screen which has already been preassembled to the underlying coarse screen. The
15 assembly is then mechanically forced through a die to compress the end caps into the assembled filtering screen and underlying coarse screen. That subassembly is then assembled onto a base pipe and secured. An outer shroud can then be secured to the underlying base pipe, overlaying the filtering screen. The ends of the subassembly comprising the filtering screen and the underlying coarse screen are sealed against the support pipe by a packing gland arrangement at both ends.

20 This design, although an improvement over prior designs, still had several limitations. Packing glands were required to accommodate relative movement due to thermal effects. This would present potentials for leakage at seals. The crimping assembly, involving overlapping of the ends and folding them over, created a thick longitudinal seam which tended to decrease the given inside diameter for a given outside diameter. The annular gap in such a design, between the outer
25 protective jacket and the filtering components, also limited the differential pressures that could be withstood across this screen.

Thus, some of the objectives of aspects of the present invention are to provide a design that could withstand greater differential pressures than prior designs. Another objective of an aspect of the present invention is to be able to form the assembly so that the fold overlapping of the prior
30 art can be eliminated, thus enabling the use of a larger inside diameter for a given outside diameter. Another objective of an aspect of the present invention is to eliminate the floating end rings used in the prior art and secure the filter directly to a supporting base pipe. Yet another objective of an aspect of the present invention is to provide a technique which will allow low-cost manufacturing of

the filter assembly. Another objective of an aspect of the present invention is to be able to hold the filter media in place with the outer jacket that is pushed on to it in the extrusion process. Another objective of an aspect of the present invention is to provide assembly that allows for use of nonmetallic components such that in long laterals, the assembly will actually induce buoyancy (cause less drag/friction during installation) to allow it to be more easily advanced into position for subsequent production. These and other advantages will be more apparent to those skilled in the art from a review of the preferred embodiment described below.

SUMMARY OF THE INVENTION

10 A method and apparatus for manufacturing any given length of a completion filter assembly is described. An outer perforated jacket is assembled over the filter media, which is itself placed over a coarse support screen or drainage layer. In the preferred embodiment, the drainage layer and outer jacket have end rings such that when advanced through a die are pushed together with the filter media in between to effect a seal of the subassembly. The subassembly can then be placed on a support pipe which is perforated, and if metallic, the end rings are welded to the support pipe to complete the assembly. Optionally, many of the components can be made of materials which lend buoyancy to the assembly so that when it is advanced into a long lateral, it will cause less drag or friction to assist in its proper positioning.

20 Accordingly, in one aspect of the present invention there is provided a downhole filter assembly, comprising:

at least two filtering layers having a tubular shape and mounted one over the other and secured to each other in a non-welding manner, said layers comprising an inner and an outer layer, said inner layer being trapped by virtue of mechanically deforming said outer layer against it; and a perforated base pipe extending through said layers, said layers having ends extending beyond the perforations in said base pipe and fixedly secured to said base pipe.

According to another aspect of the present invention there is provided a downhole filter assembly, comprising:

at least two filtering layers having a tubular shape and mounted one over the other and secured to each other in a non-welding manner;

30 a perforated base pipe extending through said layers, said layers having ends extending beyond the perforations in said base pipe and fixedly secured to said base pipe;

said layers being joined to each other by deformation resulting from an applied force;

a third layer mounted over said two layers wherein, going outwardly from said base pipe,

said layers comprise a coarse filter, a fine filter and a perforated protective jacket, and wherein all of said layers are secured to each other on their ends in a non-welding manner;

said fine filter comprising a sheet of screen material rolled into a tubular shape with ends overlapping by less than about 10°;

5 said protective jacket and said coarse filter comprising end rings with said fine filter extending in between;

said fine filter being squeezed between said rings on both ends to hold the assembly of said filter and protective jacket together.

10 According to yet another aspect of the present invention there is provided a method of running in a screen for downhole use, comprising:

assembling a screen to tubing for running into a wellbore;

providing said screen from materials that enhance buoyancy as compared to steel construction;

using said buoyancy to enhance advancement of said screen downhole; and

15 advancing the screen downhole.

BRIEF DESCRIPTION OF THE DRAWINGS

An embodiment of the present invention will now be described more fully with reference to the accompanying drawings in which:

20 Figure 1 shows in sectional cross-section the subassembly prior to advancement through a die.

Figure 2 shows the subassembly after having been advanced through the die and a base pipe inserted and welded thereto.

Figure 3 is a sectional along lines 3-3 of Figure 2.

25

DETAILED DESCRIPTION OF THE PREFERRED EMBODIMENT

The preferred embodiment is illustrated in Figure 1. An outer shroud **10** has an end ring **12**. It has a similar end ring on the other end, which is not shown. The structure of the outer shroud **10** is a tubular perforated member whose preferred construction is illustrated in U.S. Patent 5,849,188 as a jacket **16**. Referring to Figures 5a and 5b of that patent, the jacket can be formed by a spiral pattern of punched in components **14** which define opposing flowpaths from the outer surface **16** through openings such as **18** in order to reach the next layer, which is the filter material **20**. The preferred structure of the filter material **20** is also illustrated in U.S. Patent 5,849,188 as item 14.

30

Below the filter material **20** is a coarse filter **22** which is essentially formed of an elongated material **24** which can have a variety of cross-sectional shapes, spirally wound so as to create a continuing spiral gap between each winding as the windings are supported on longitudinally oriented support rods **26**. The coarse filter may also be woven to create said gap. The end of the structure
5 can optionally contain a solid ring **28**. The filter material **20** is rolled into a tubular shape and the ends are minimally overlapped on each other. One of the ends, shown in Figure 1 as item **30**, winds up being between ring **28** and ring **12** on outer shroud **10**.

The coarse filter **22**, which is preferred, is also illustrated in U.S. Patent 5,849,188. While the specific design of the three components shown in Figure 1 can be preferably made as illustrated
10 in U.S. Patent 5,849,188, other constructions for the three layers are within the purview of the invention. For specific applications, different combinations of two of the three layers previously described can be used. For example, the innermost coarse filter **22** can be eliminated. The filter material **20** in some applications can be eliminated. The outer shroud **10** can also be eliminated.

Referring again to Figure 1, it can be seen that the assembly is forced through a die **32**
15 which effectively seals the end **30** of the filter material **20** as it is physically compressed between rings **12** and **28**. The outer shroud **10** is plastically deformed by the die **32** such that its inwardly directed protrusions **14** are brought into contact with the filter material **20**. This contact helps to stabilize the filter material, while the passage through the die **32** seals the subassembly at

5 either end. The entire subassembly shown in Figure 1 is shown in Figure 2 with a base pipe **34**
extended through it. The base pipe **34** has threaded or other well-known connections **37** at
either end, and the subassembly **36** is continuously welded or otherwise joined as indicated at
38. The subassembly of at least two components can also be secured to the base pipe by
passing the base pipe through the die with it. The base pipe **34** has a series of openings **40** to
10 complete the filter assembly.

Figure 3 indicates a section through the completed assembly, showing the base pipe **34**
with its openings **40**. Outside of that are the rods **26** which support the spiral windings of the
elongated material **24** to form the coarse filter **22**. Outside of that is the filter material **20**.
Centerline **42**, in conjunction with dashed line **44**, is intended to graphically show the amount
15 of overlap between the ends of the filter material **20**. The overlap is preferably kept to a
minimum such as approximately 10° or less which may separate the centerline **42** from the
dashed line **44**, representing the degree of overlap. The amount of overlap is sufficient to
eliminate the possibility of seam leakage. When the outer shroud **10** is pressed onto the filter
material **20** as a result of advancing it through die **32**, the overlapping portion between centerline
20 **42** and dashed line **44** are firmly held together against the support of the coarse filter **22**.

The advantages of this design should now be readily apparent to those skilled in the art.
The close-fit nature of the components, particularly the outer shroud **10** and the filter material
20, allows the assembly to withstand significantly greater differential pressure than the
constructions of prior designs, such as that illustrated in U.S. Patent 5,611,399. Differentials in
25 the order of 2000 psi could now be used, whereas with prior designs, the maximum desirable
differential pressures were in the order of 600 psi. The need for allowances for differential
expansion at the ends of the filter assembly, as illustrated in U.S. Patent 5,611,399, is
eliminated. The subassembly **36** is directly secured and sealed to the base pipe **34**. Because
of the way it is made as described above, differential expansion is no longer a significant issue.

30 Those skilled in the art can appreciate that with the assembly shown in Figure 1, the
filter material **20** is not structural and thus can be made of a variety of different materials,
including plastics, various fabrics or composite materials. The selected material for the filter
material **20** needs to be capable of remaining structurally intact, despite advancement of the

5 assembly 36 through the die 32. Similarly, other components of the assembly 36 can be made
of nonmetals so as to render the assembly 36 more buoyant. The scope of the invention
encompasses any downhole filter assembly made with components that make it buoyant or
more buoyant. When the assembly is inserted into a lengthy lateral, its heightened buoyancy
can be a significant aid in advancing the assembly 36 to the appropriate position. Clearly, the
10 choice of materials will affect the available differential pressures that the assembly 36 can
withstand. Another alternative is to use buoyant materials for the base pipe 34 to accomplish
this purpose. The subassembly 36 would then be secured to the base pipe 34 by techniques
such as adhesives or other joining compounds which are compatible with the temperatures,
pressures and chemicals of the specific application. Thus, for example, the base pipe can be
15 made of glass fiber epoxy composites such as anhydride or aromatic amine-cured epoxy pipe
or SDT^{*} downhole tubing made by Smith Fiberglass Products Inc. Other types of fiber or polymer
matrix can be used to get the requisite strength and abrasion properties in combination with a
low density. Some examples are polyphenylene sulfide, polyketones such as PEK^{*} or PEEK^{*},
epoxy vinyl ester, phenolic resins, bisphenol, A fumerate, or isophthalic polyester resins. These
20 materials can be combined with carbon fiber, polyester fiber, aramid fiber, glass fiber or other
manmade or naturally occurring fiber.

The method of assembly, as illustrated in Figure 1, further ensures that the filter material
20 is uniformly stressed. The assembly shown in Figure 2 is sufficiently structurally strong to
permit well killing against the screen. As a result of pulling the assembly 36 through the die 32,
25 the filter material acts in a spring-like manner against the outer shroud 10. Alternatively, the
coarse filter 22, after pulling through the die 32, can impart spring-like forces to the filter media
20 against the outer shroud 10. The filter material 20 can be a simple mesh or a twill or a
porous material and can be made of any one of many materials compatible with well conditions
and the mechanical stresses of the application. Buoyant materials can also be used.

30 Those skilled in the art will appreciate that apart from the technique illustrated in Figures
1 and 2, a filter assembly can be constructed with sufficiently low density due to the use of
composites or other low-density materials so as to allow a filter assembly, regardless of how it
is constructed to be more easily inserted into a lengthy lateral due to the buoyancy effect. Thus,

^{*}trade-mark

5 a filter material can be attached to a base pipe **34** with or without a shroud such as **10**, as one potential assembly that can be used for installation and laterals to take advantage of the buoyant characteristics. Additionally, a low-density material can be used for the outer shroud **10** and it can have openings of various shapes and sizes created by a variety of techniques.

10 The foregoing disclosure and description of the invention are illustrative and explanatory thereof, and various changes in the size, shape and materials, as well as in the details of the illustrated construction, may be made without departing from the spirit of the invention.

What is claimed is:

1. A downhole filter assembly, comprising:
at least two filtering layers having a tubular shape and mounted one over the other and secured to each other in a non-welding manner, said layers comprising an inner and an outer layer, said inner layer being trapped by virtue of mechanically deforming said outer layer against it; and
a perforated base pipe extending through said layers, said layers having ends extending beyond the perforations in said base pipe and fixedly secured to said base pipe.
2. The assembly of claim 1, wherein:
said layers are joined to each other by deformation resulting from an applied force.
3. The assembly of claim 2, wherein:
one of said layers is formed from a sheet rolled into a tubular shape with ends overlapping by less than about 10°.
4. The assembly of claim 2, wherein:
at least one of said layers further comprises end rings, said layers secured at said end rings by a mechanical deformation.
5. The assembly of claim 4, wherein:
said end rings are non-removably attached to said base pipe to seal the ends of said layers.
6. The assembly of claim 2, further comprising:
a third layer mounted over said two layers wherein, going outwardly from said base pipe, said layers comprise a coarse filter, a fine filter and a perforated protective jacket, and wherein all of said layers are secured to each other on their ends in a non-welding manner.
7. The assembly of claim 6, wherein:
said filter layers and said protective jacket are secured on said ends by deformation resulting from an applied force.
8. The assembly of claim 7, wherein:

said protective jacket comprises inwardly directed protrusions in contact with said fine filter at spaced locations over its length between said end portions which are secured to said fine filter.

9. The assembly of claim 7, wherein:

said assembly of said coarse and fine filters and said protective jacket are non-removably attached on said ends to said base pipe.

10. The assembly of claim 6, wherein:

said fine filter comprises of a sheet of screen material rolled into a tubular shape with ends overlapping by less than about 10°.

11. The assembly of claim 6, wherein:

said protective jacket contacts said fine filter between said ends and said filter assembly can resist internal burst pressure of over about 1000 psig.

12. A downhole filter assembly, comprising:

at least two filtering layers having a tubular shape and mounted one over the other and secured to each other in a non-welding manner;

a perforated base pipe extending through said layers, said layers having ends extending beyond the perforations in said base pipe and fixedly secured to said base pipe;

said layers being joined to each other by deformation resulting from an applied force;

a third layer mounted over said two layers wherein, going outwardly from said base pipe, said layers comprise a coarse filter, a fine filter and a perforated protective jacket, and wherein all of said layers are secured to each other on their ends in a non-welding manner;

said fine filter comprising a sheet of screen material rolled into a tubular shape with ends overlapping by less than about 10°;

said protective jacket and said coarse filter comprising end rings with said fine filter extending in between;

said fine filter being squeezed between said rings on both ends to hold the assembly of said filter and protective jacket together.

13. The assembly of claim 12, wherein:

said protective jacket comprises projections oriented toward said fine filter which are in contact, at spaced locations, with said fine filter between said end rings.

14. A method of running in a screen for downhole use, comprising:
 - assembling a screen to tubing for running into a wellbore;
 - providing said screen from materials that enhance buoyancy as compared to steel construction;
 - using said buoyancy to enhance advancement of said screen downhole; and
 - advancing the screen downhole.
15. The method of claim 14, further comprising:
 - providing portions of said screen in non-metal materials.
16. The method of claim 15, further comprising:
 - providing the entirety of said screen in non-metal materials.
17. The method of claim 15, further comprising:
 - providing a portion of said screen in composite materials.
18. The method of claim 15, further comprising:
 - providing a perforated base pipe, a coarse screen and a fine screen as said screen;
 - providing one or more of said base pipe, coarse screen and fine screen in a non-metal material.
19. The method of claim 18, further comprising:
 - providing at least one of said base pipe, coarse screen and fine screen in fiber epoxy composite material.

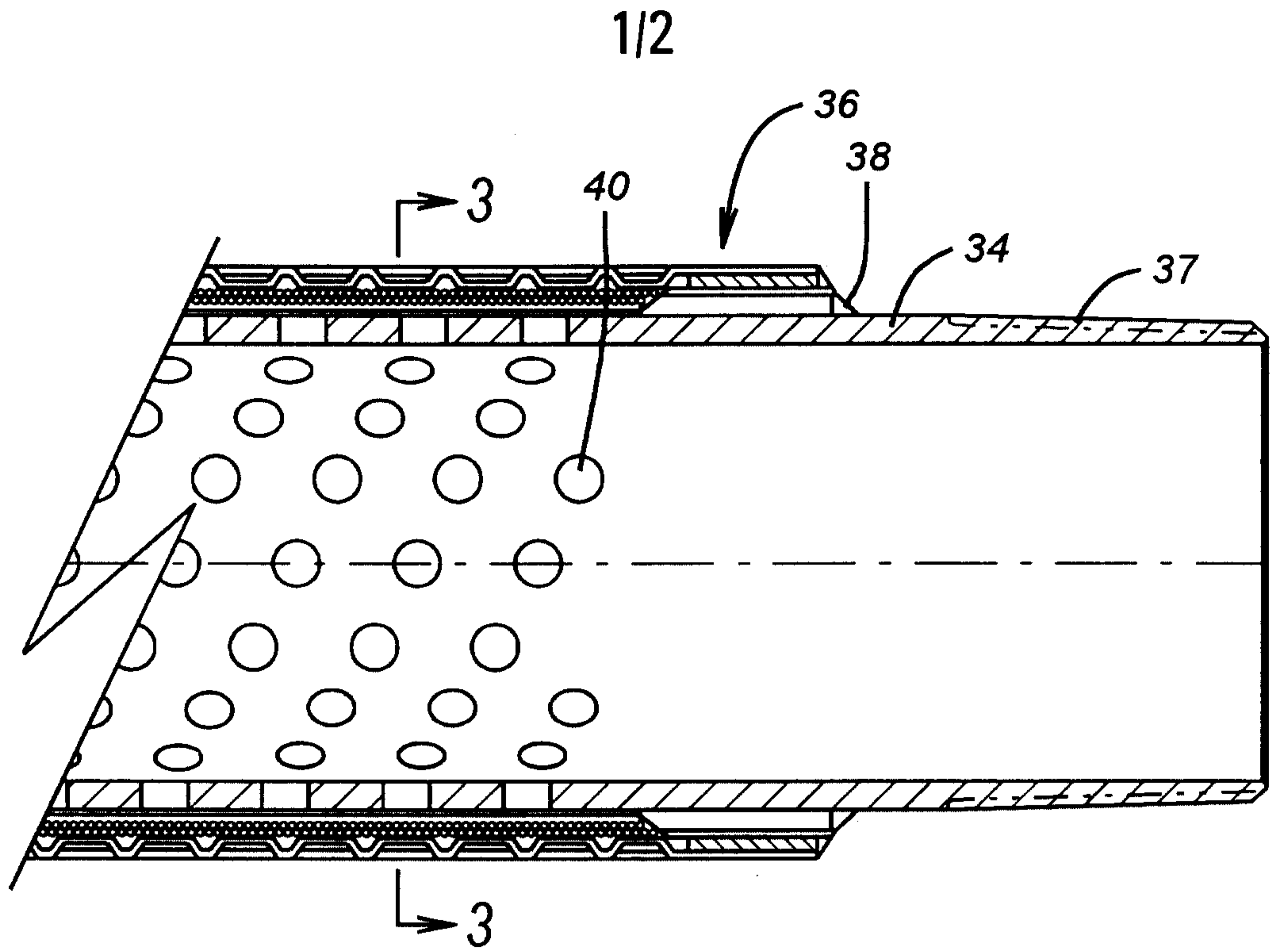

FIG. 2

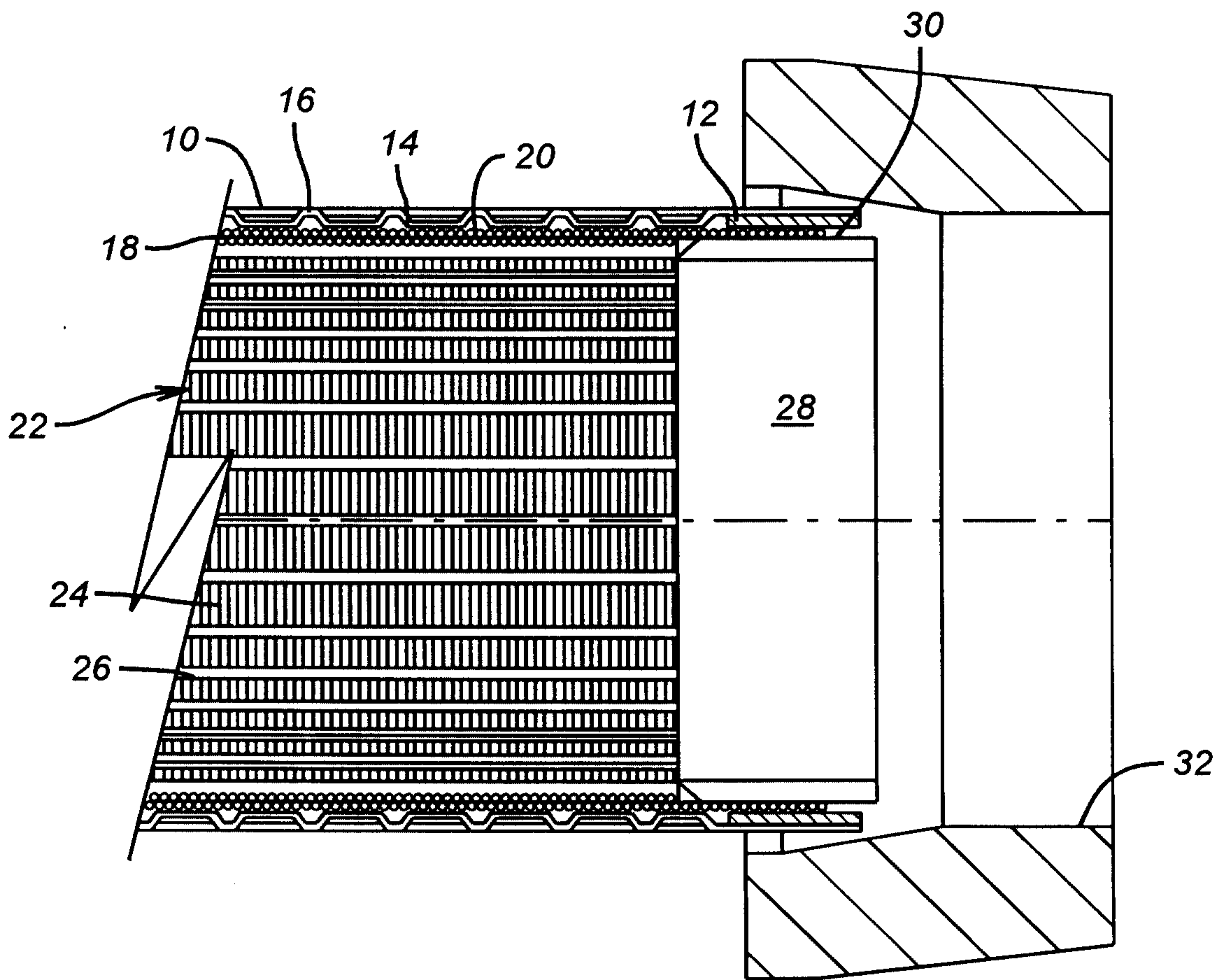

FIG. 1

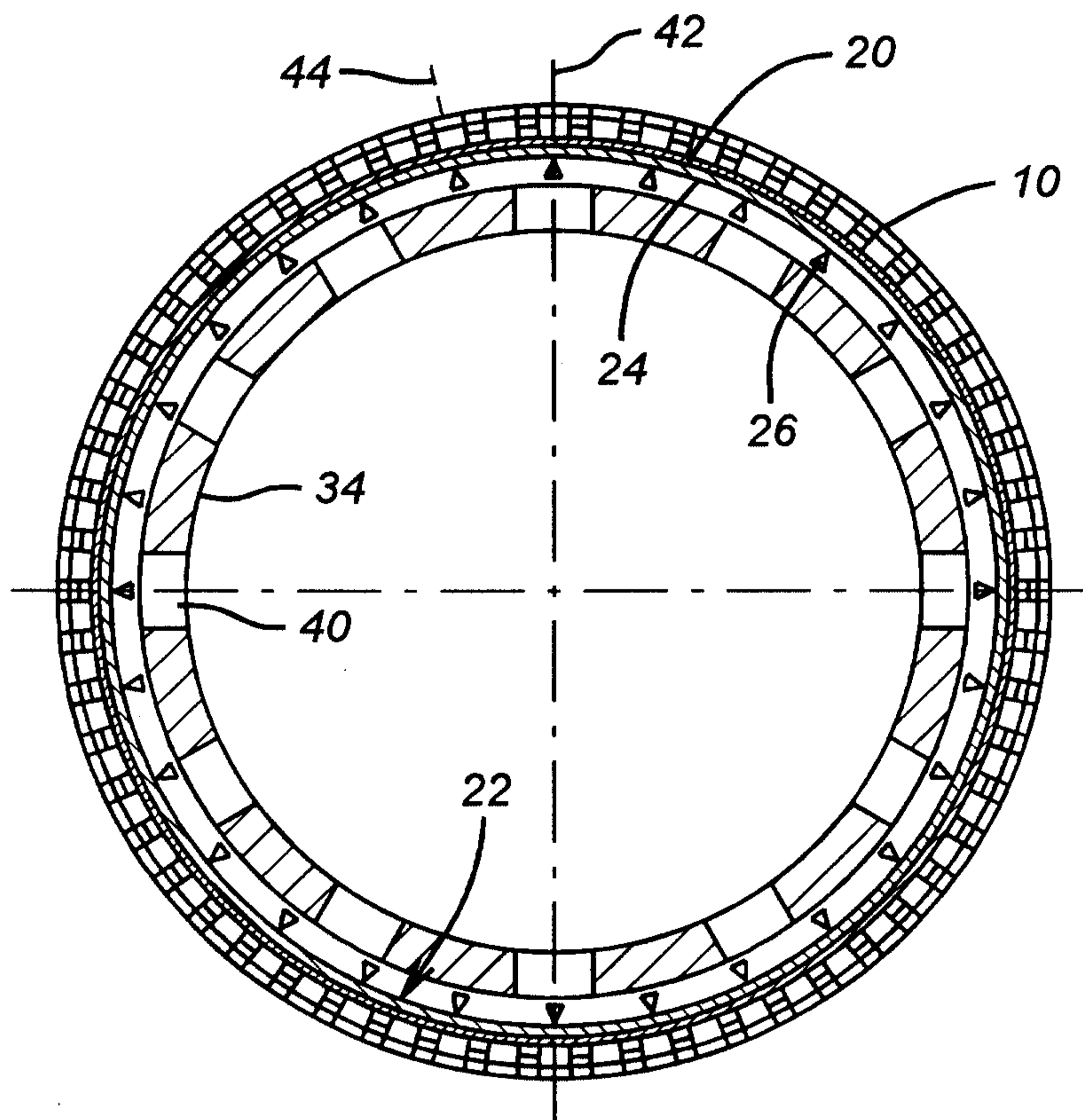

FIG. 3

