



US 20070032357A1

(19) **United States**

(12) **Patent Application Publication**

Piane, JR.

(10) **Pub. No.: US 2007/0032357 A1**

(43) **Pub. Date: Feb. 8, 2007**

(54) **USER-DEFINED EXERCISE APPARATUS**

Publication Classification

(76) Inventor: **Robert A. Piane JR.**, Newark, DE (US)

(51) **Int. Cl.**
A63B 26/00 (2006.01)

(52) **U.S. Cl.** **482/142**

Correspondence Address:
MILDE & HOFFBERG, LLP
10 BANK STREET
SUITE 460
WHITE PLAINS, NY 10606 (US)

(57) **ABSTRACT**

(21) Appl. No.: **11/439,081**

A kit of parts is provided for assembly into exercise apparatus of various configurations, as desired and defined by the user. The apparatus, when configured to form a supporting cell, conveniently allows the attachment of a plurality of exercise devices of the same or different type while, in addition, can be used as a storage center for items normally found at a fitness center such as bands, weights, balls, bars, barbells, etc.

(22) Filed: **May 23, 2006**

Related U.S. Application Data

(60) Provisional application No. 60/688,069, filed on Jun. 7, 2005.

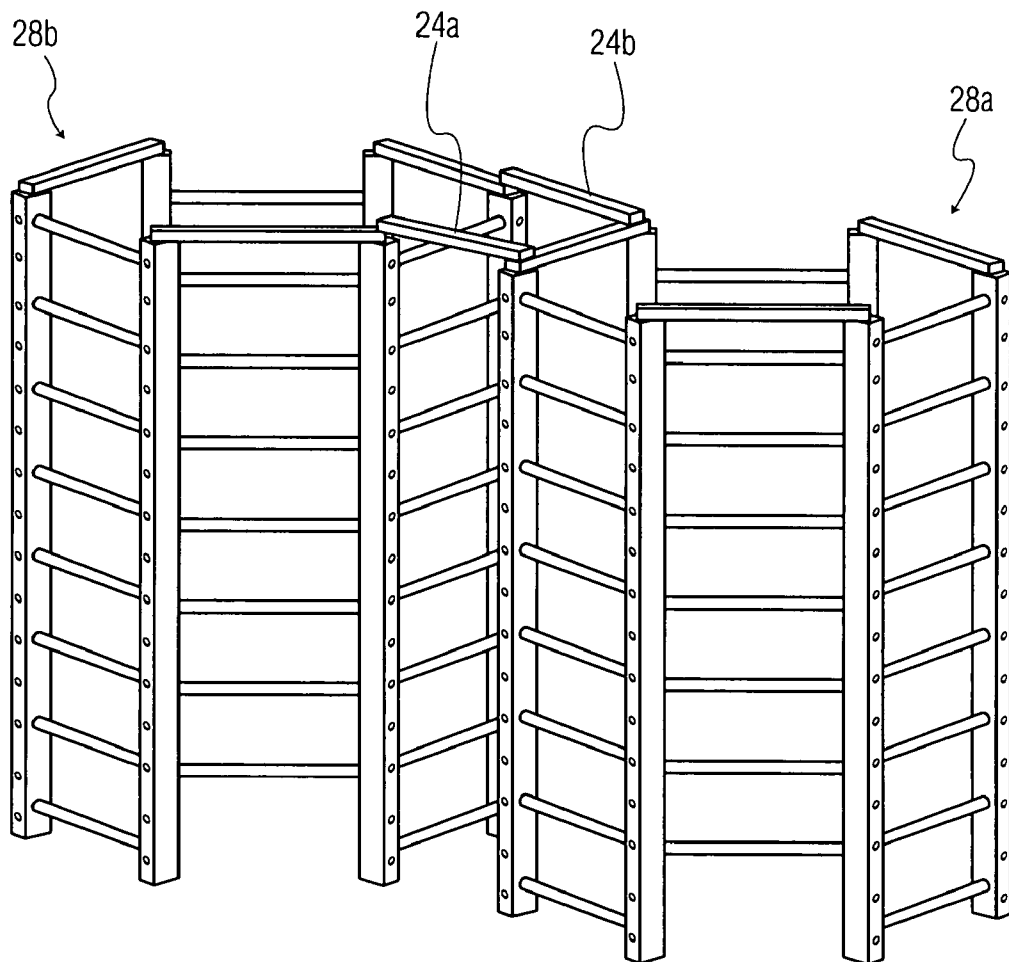

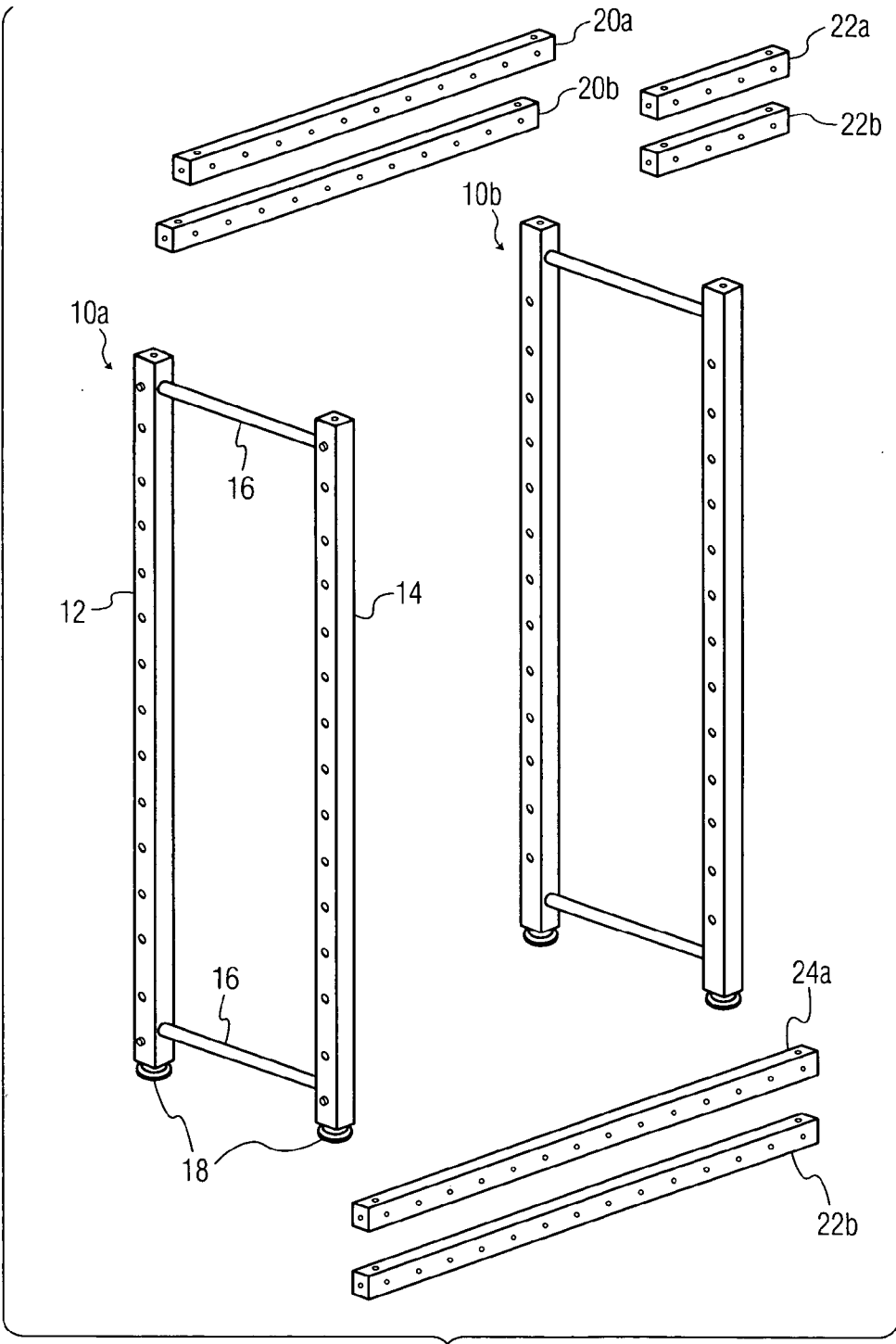

FIG. 1

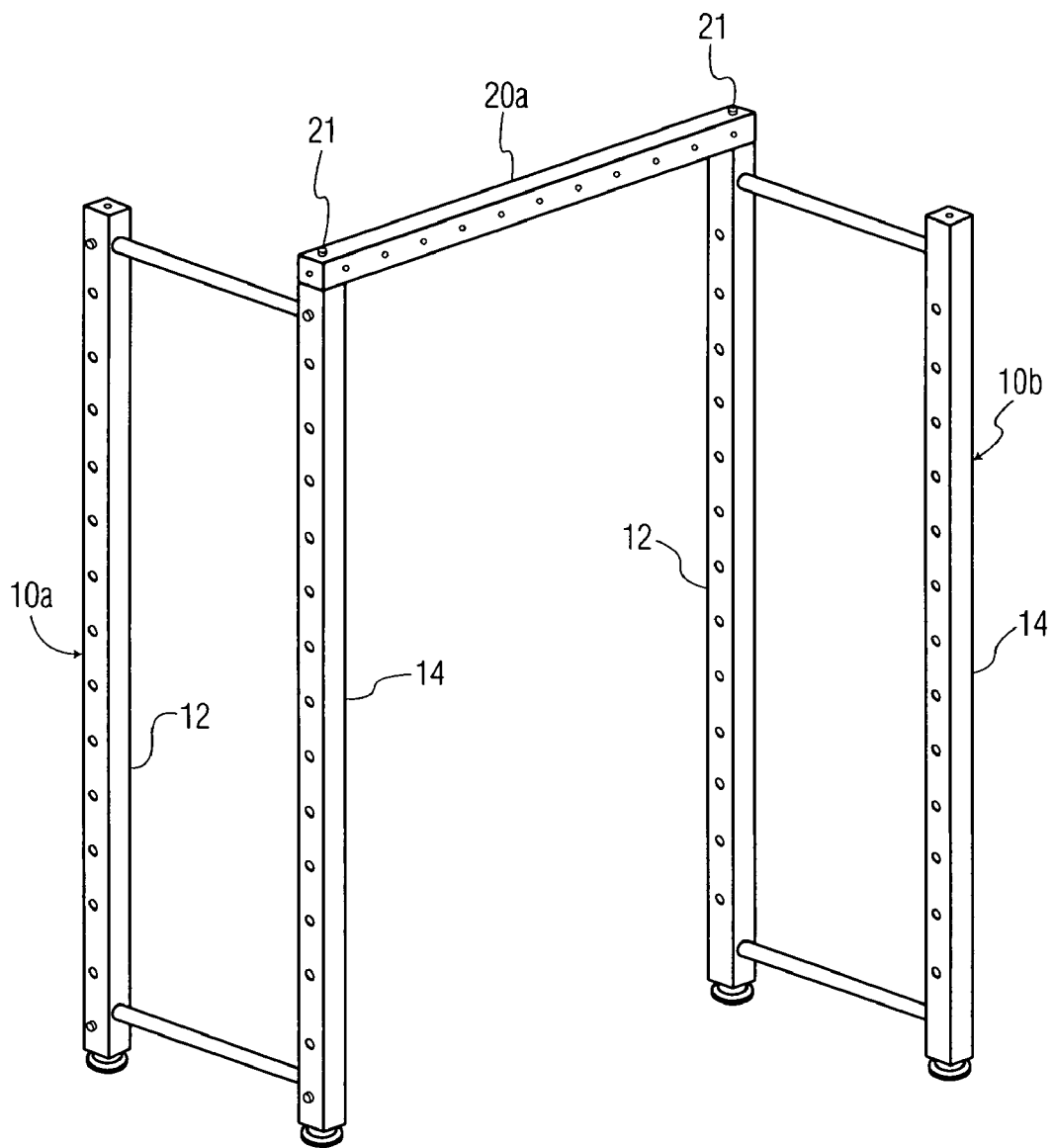

FIG. 2A

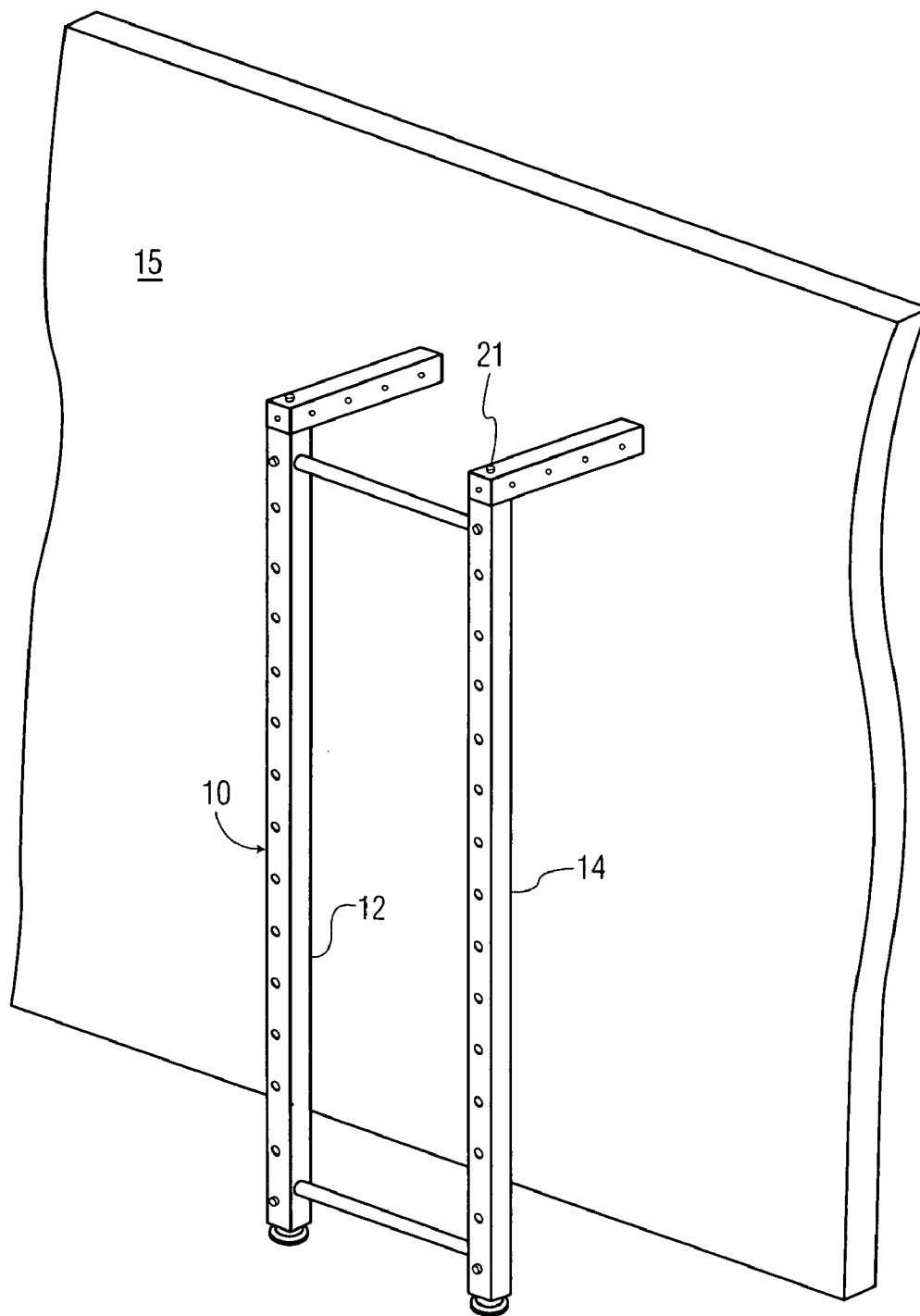

FIG. 2B

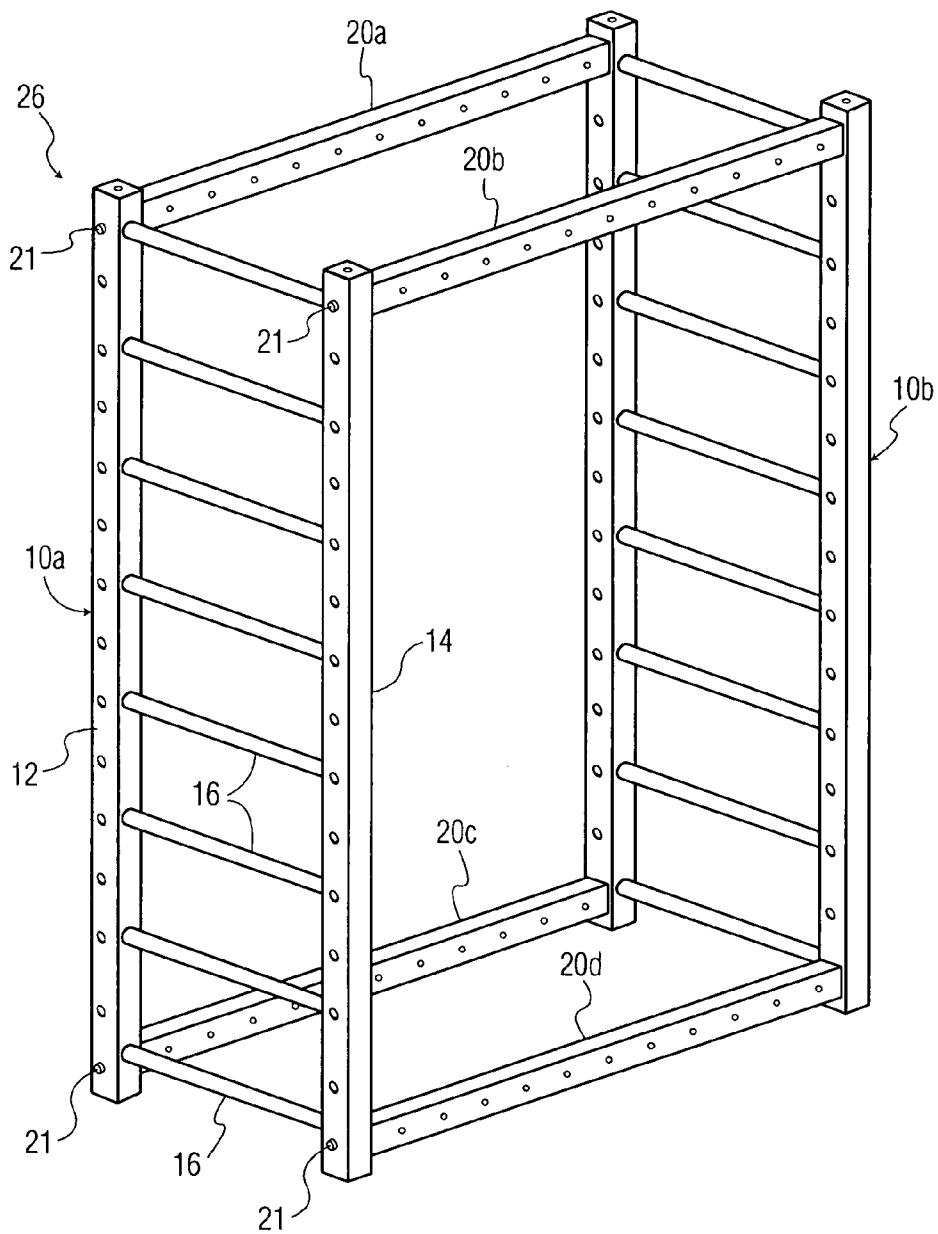

FIG. 3

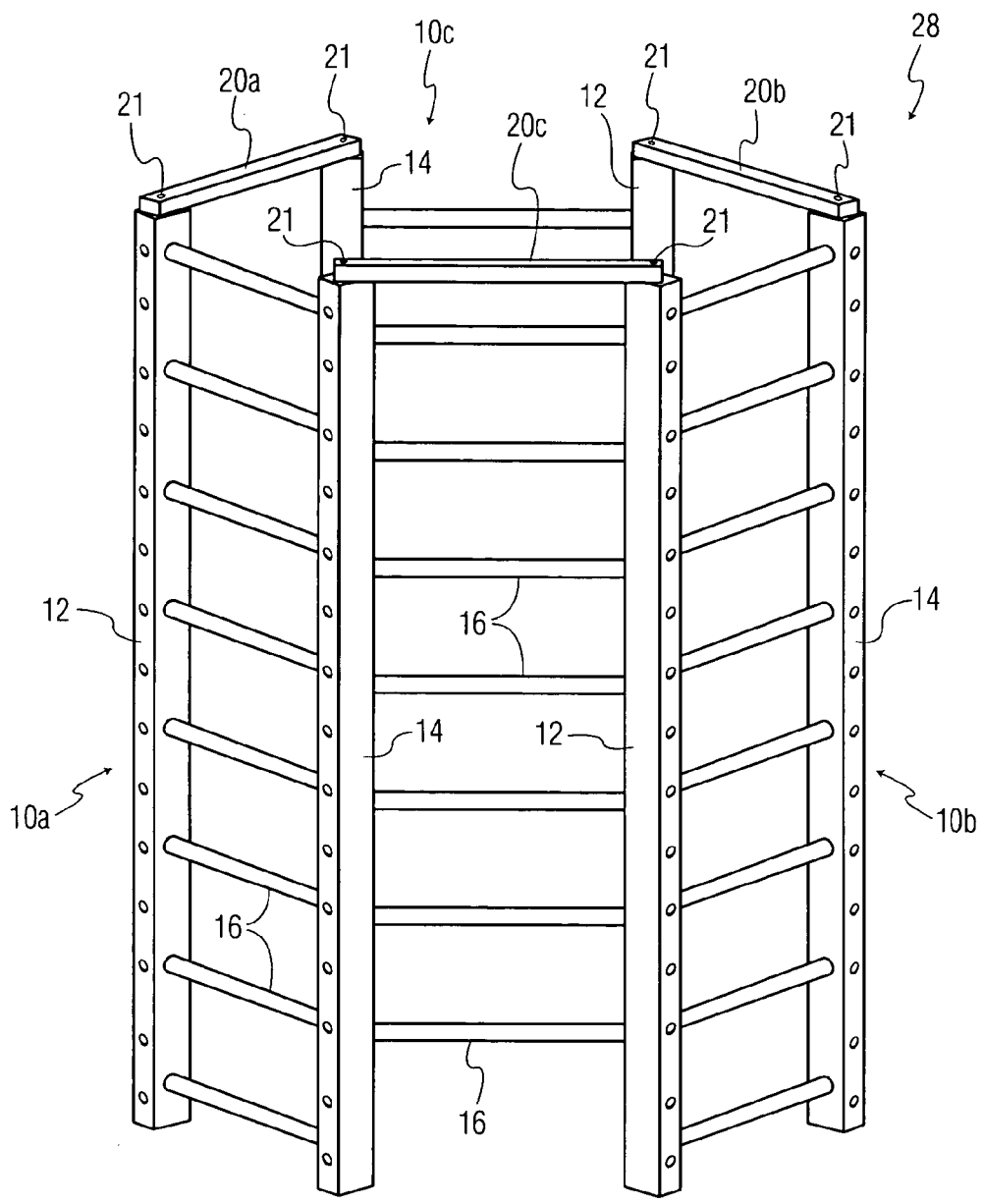

FIG. 4

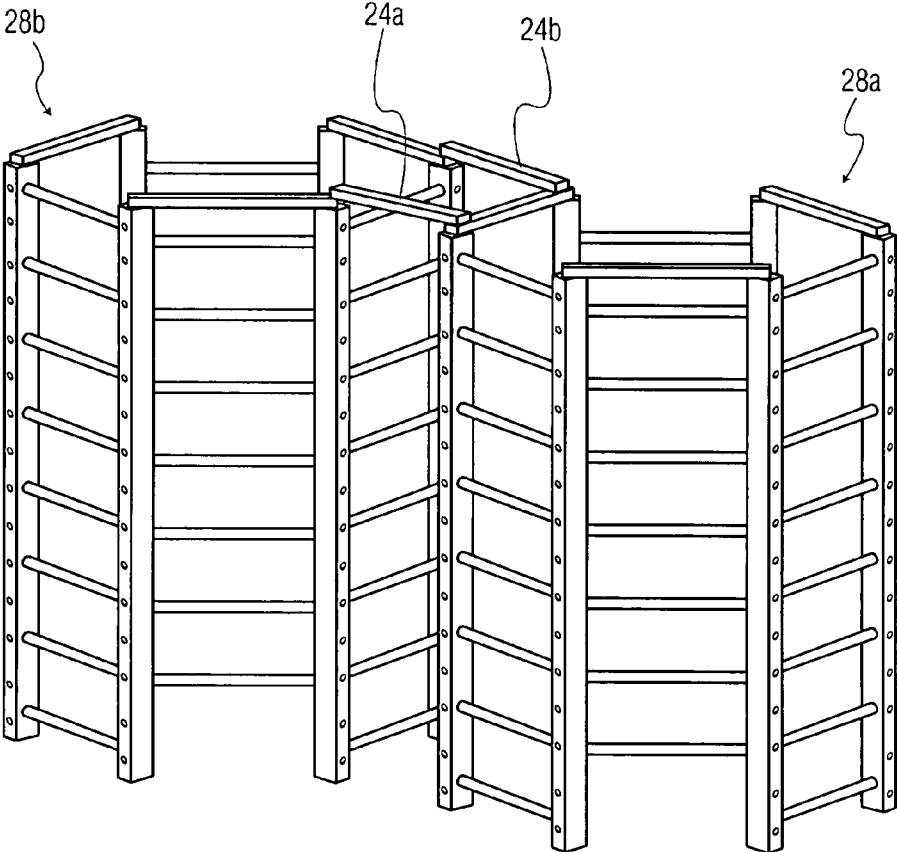

FIG. 5

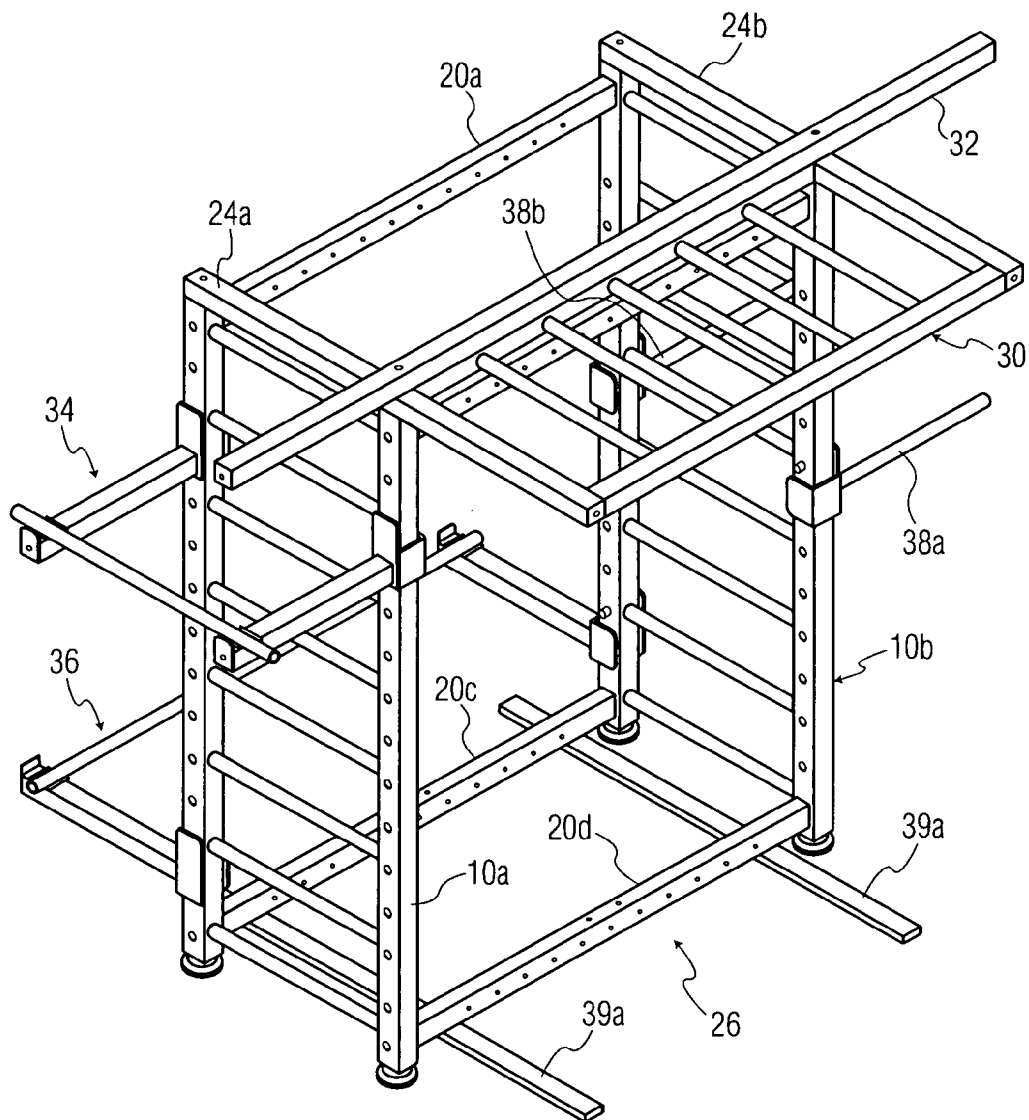

FIG. 6

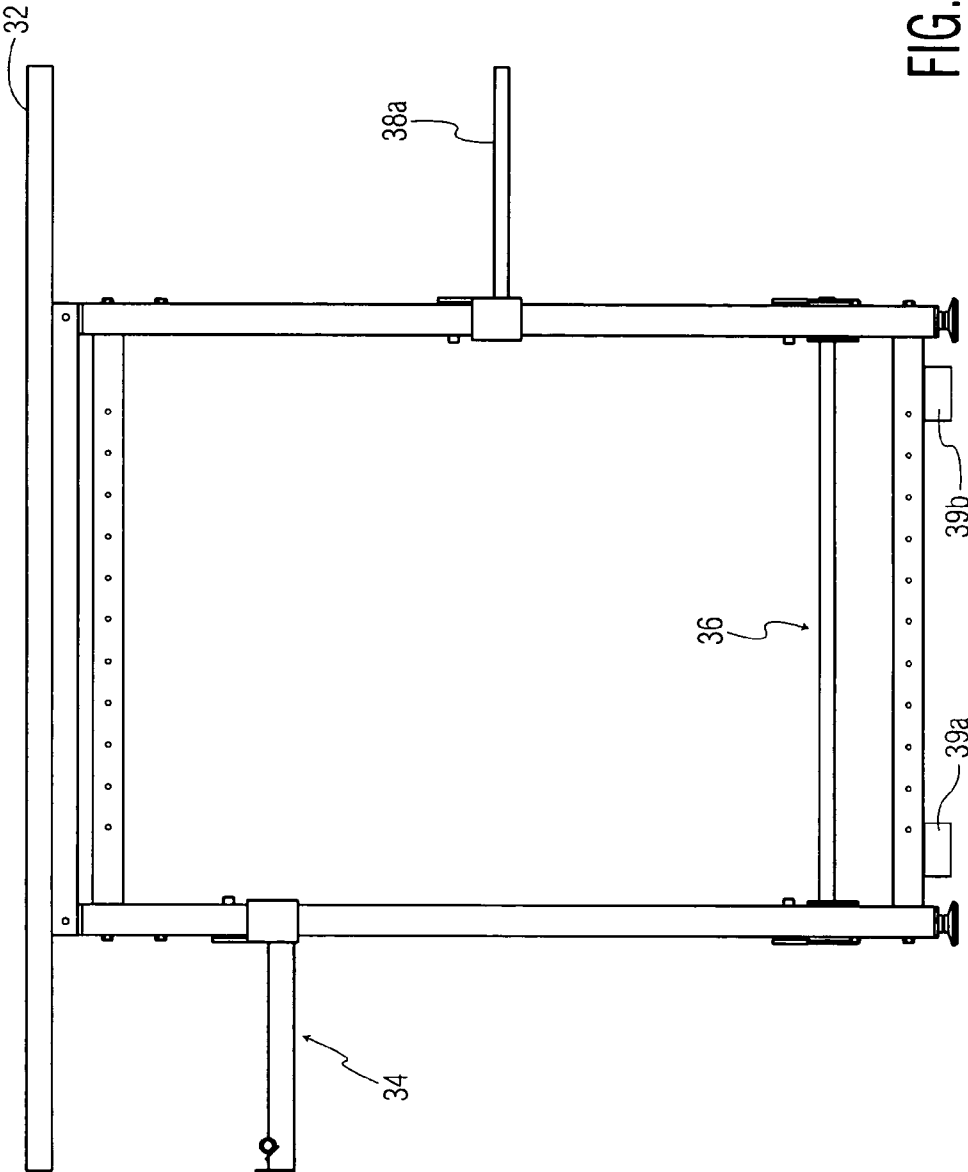

FIG. 7

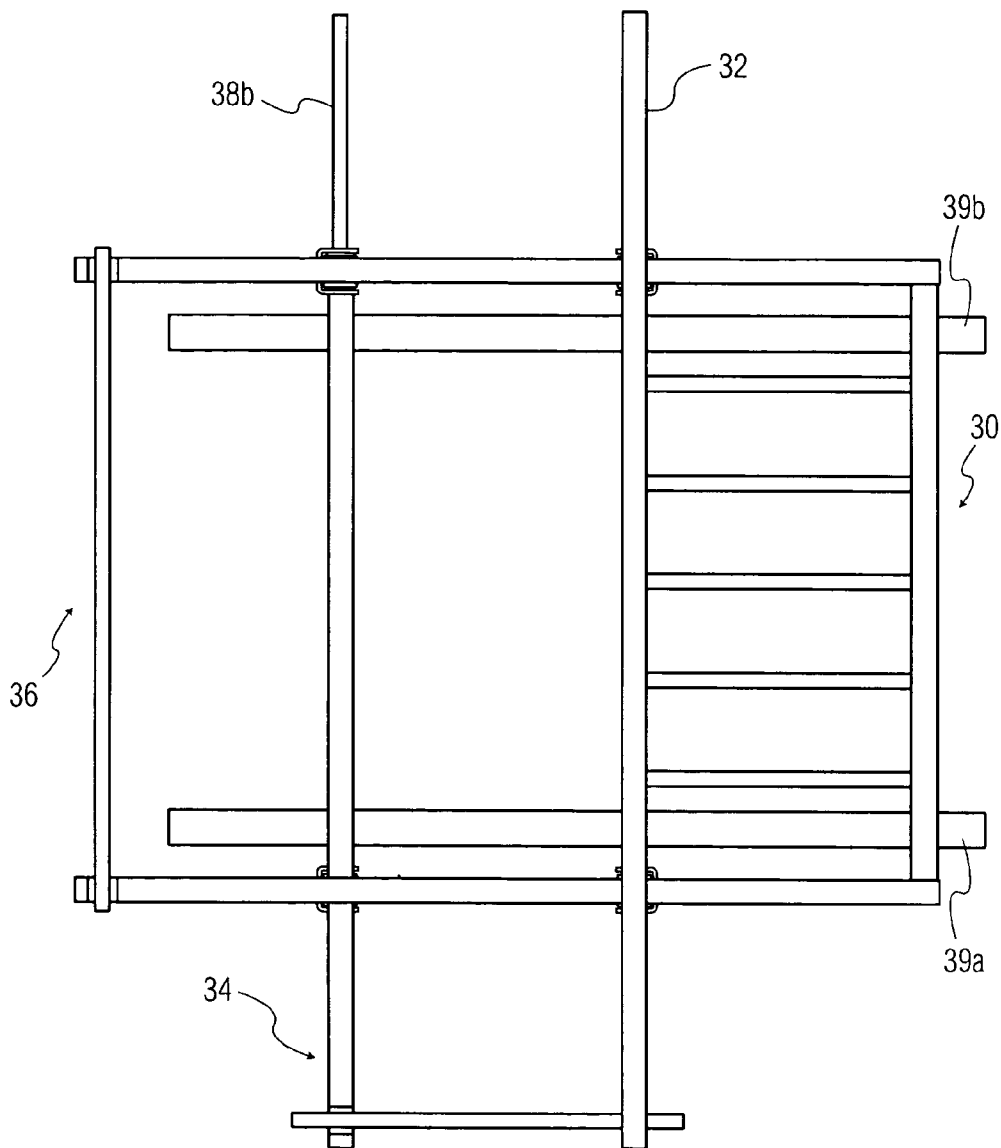

FIG. 8

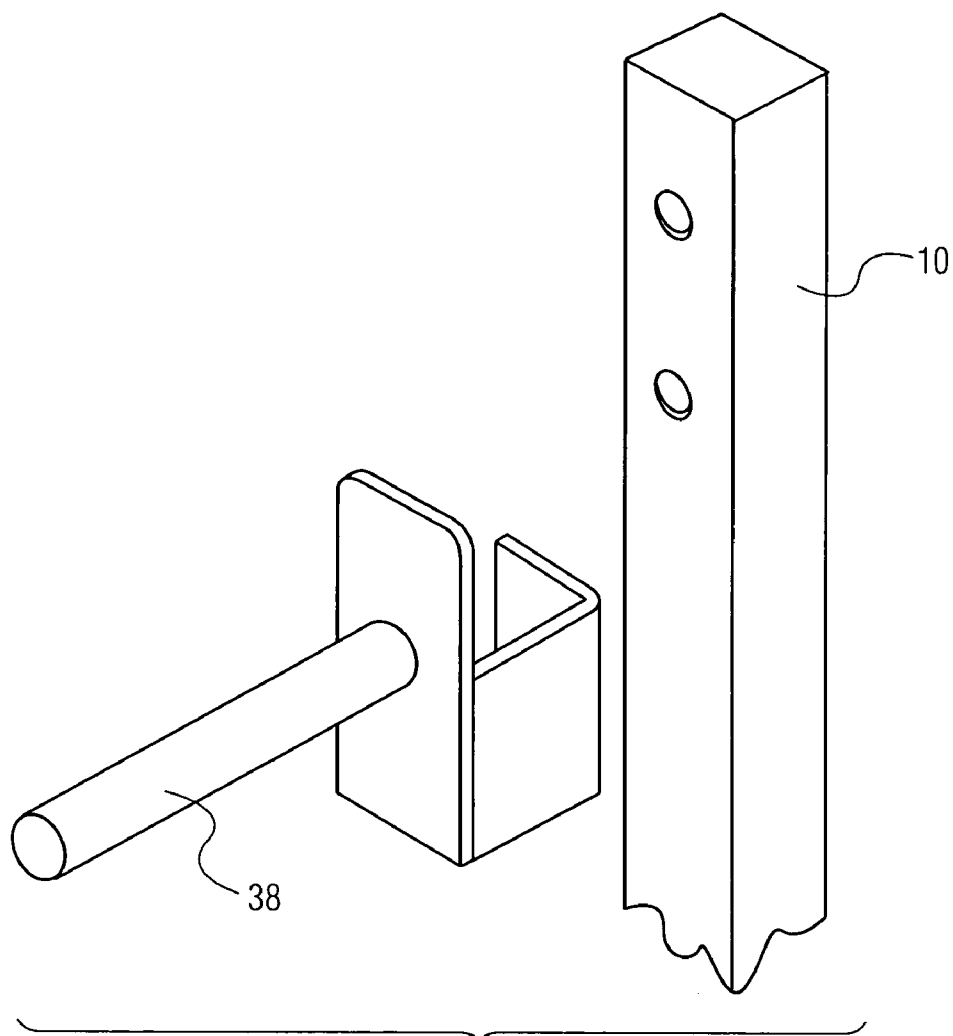

FIG. 9A

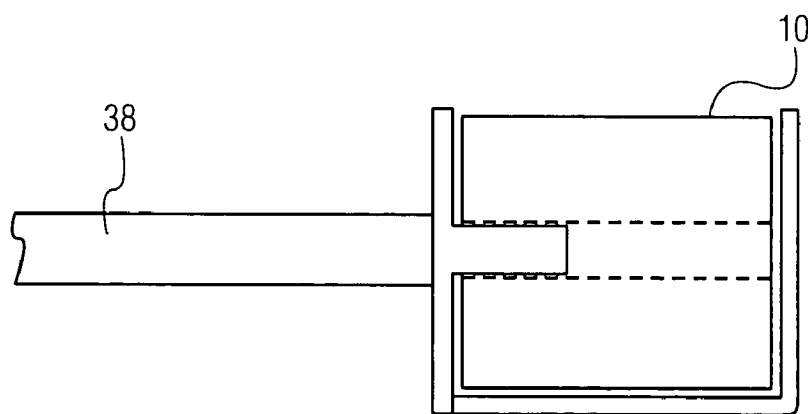

FIG. 9B

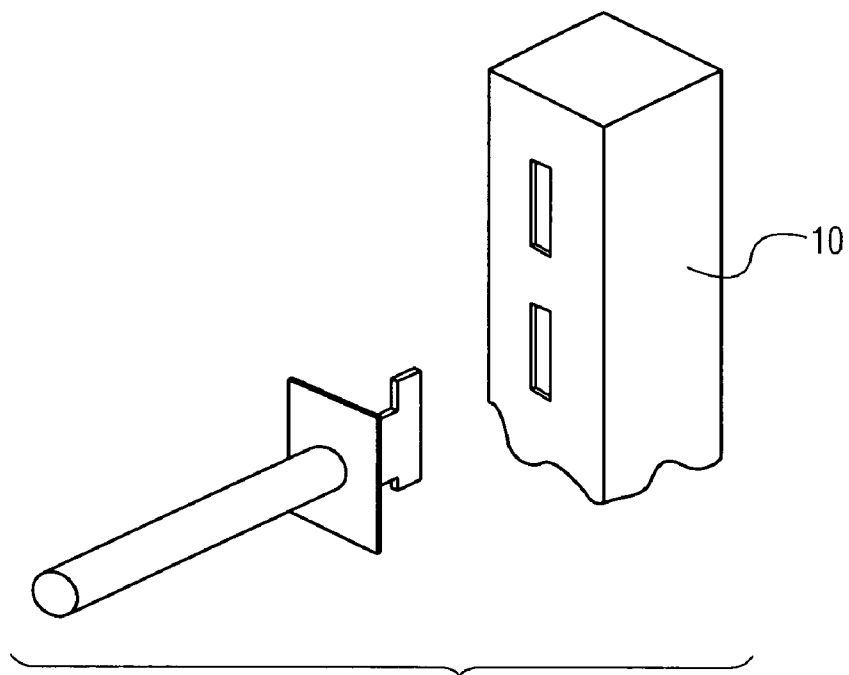

FIG. 10

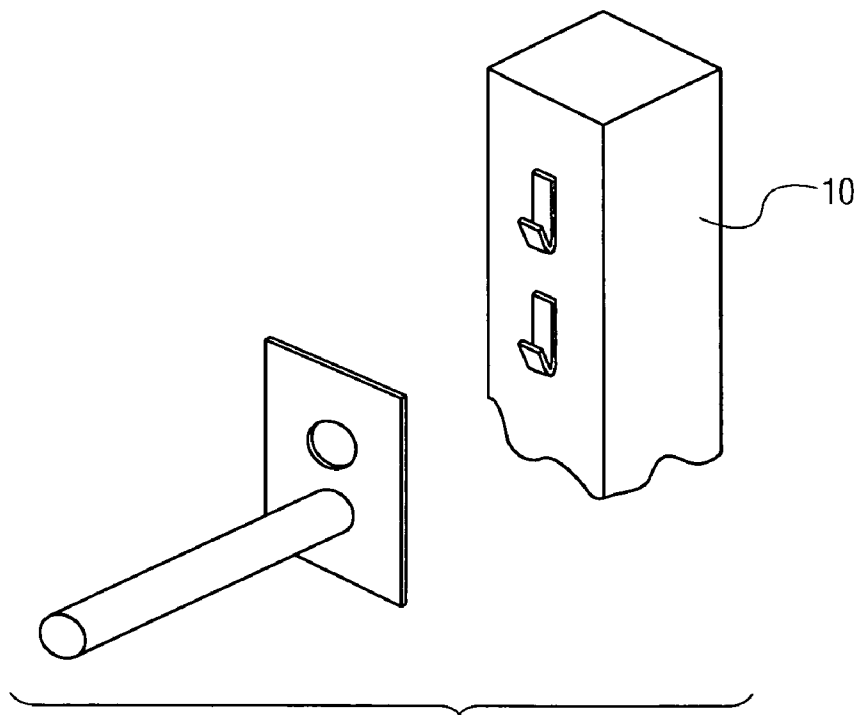

FIG. 11

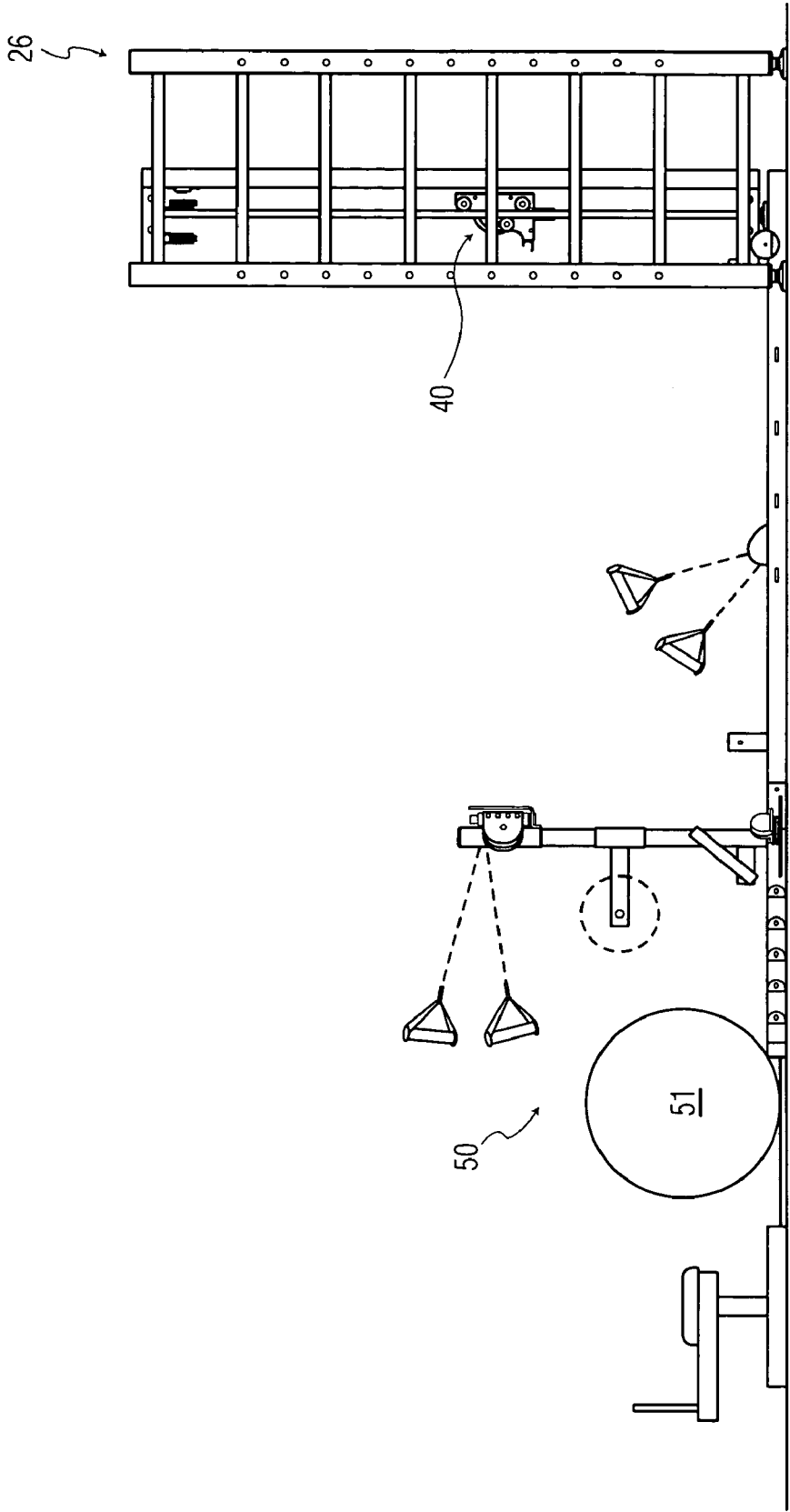

FIG. 12

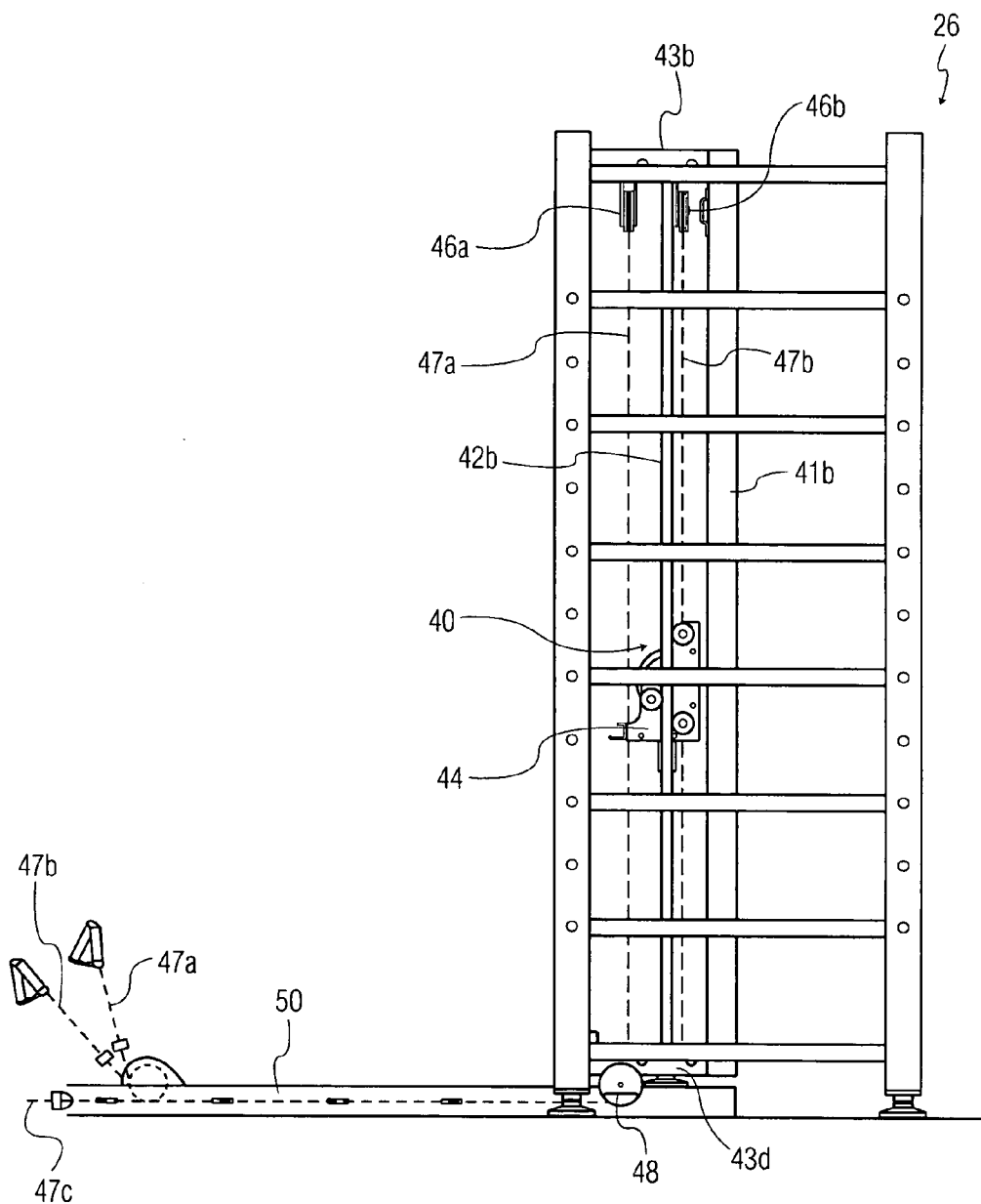

FIG. 13

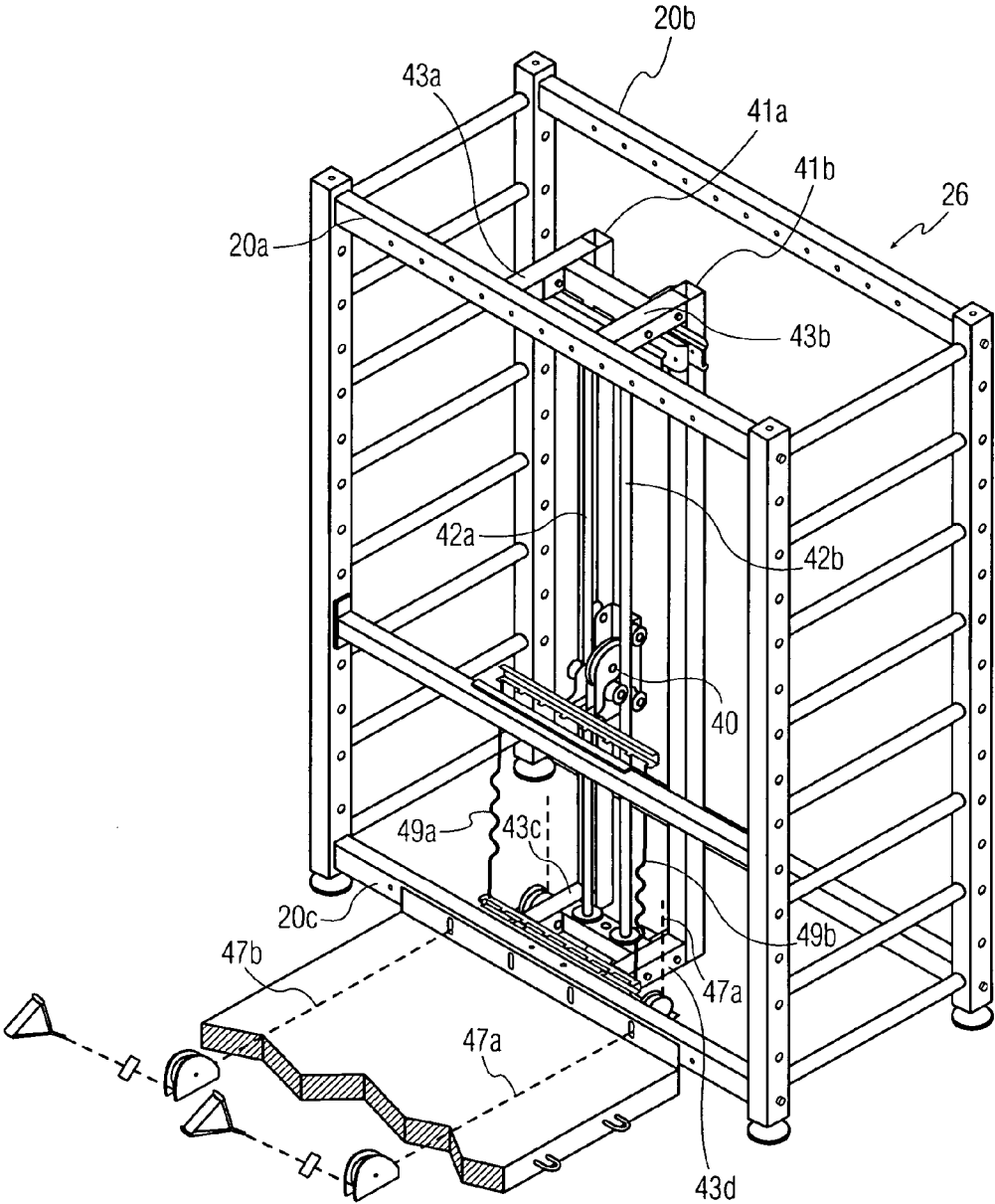

FIG. 14

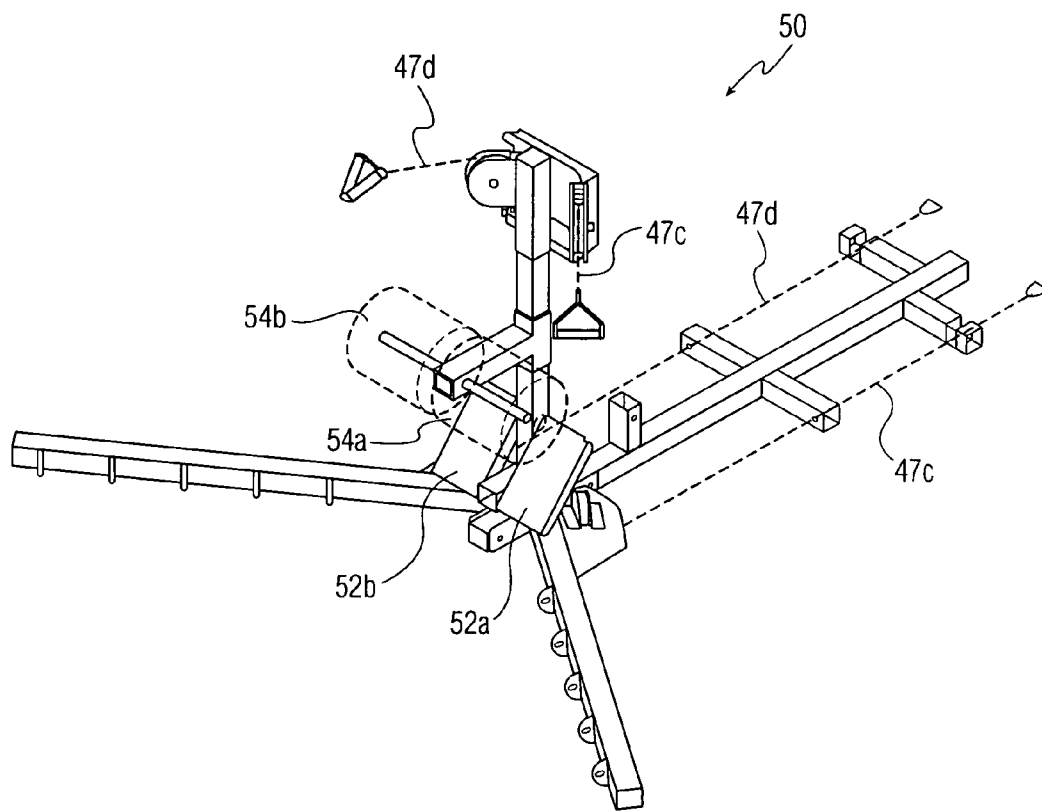

FIG. 15

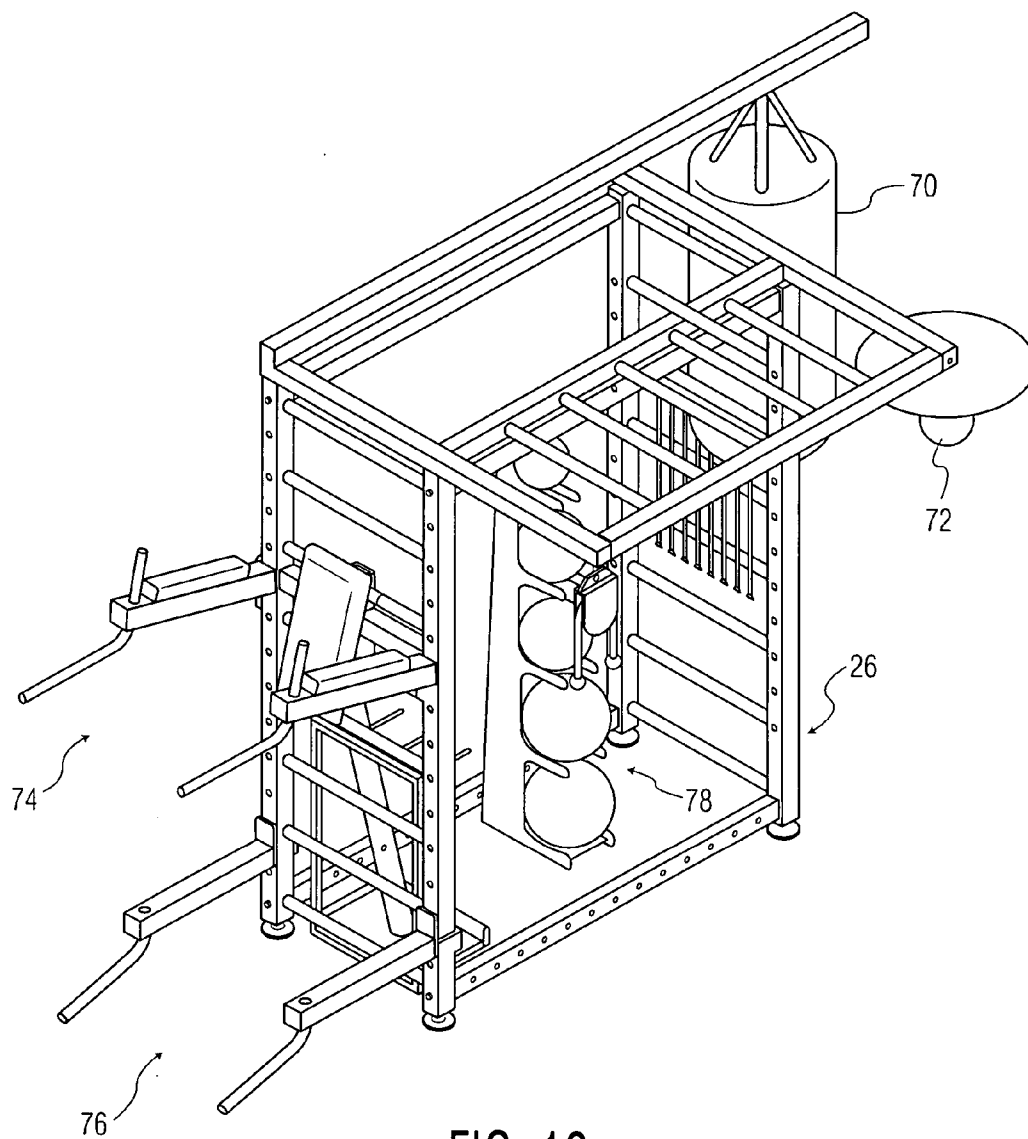

FIG. 16

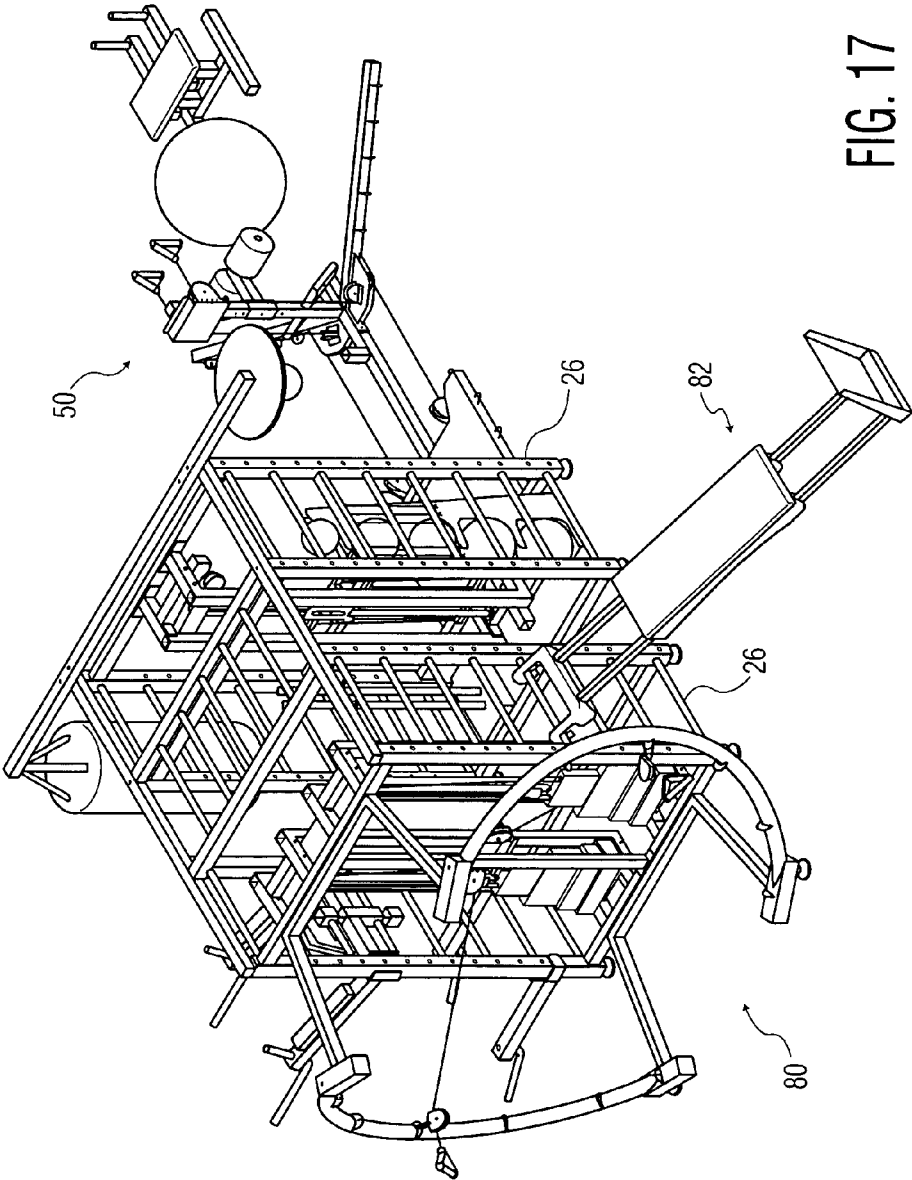

FIG. 17

USER-DEFINED EXERCISE APPARATUS

CROSS-REFERENCE TO RELATED APPLICATION

[0001] This application claims priority from Provisional Patent Application No. 60/688,069 filed Jun. 7, 2005, and entitled "SUPER CELL UNIVERSALLY INTER-CHANGEABLE WORKOUT STATION".

BACKGROUND OF THE INVENTION

[0002] The present invention relates to apparatus, including a kit of assembly parts, which enables the construction of one or more exercise workout stations, as defined and assembled by a user.

[0003] There are a great many individualized pieces of fitness and exercise equipment commercially available at the present time. These pieces of equipment are normally single-purpose by design, but in some instances a plurality of such pieces of equipment are combined to form multi-purpose exercise apparatus.

[0004] Such "multi-station" machines are comprised of a series of weight stacks, seats, cables, benches, bars, pulleys and the like, all configured into a preset, fixed arrangement. Although these multi-station machines offer a variety of exercise devices and permit multiple users to work out at the same time, they lack the versatility of being integrated with almost any other type of exercise equipment. Moreover, once configured at the factory, these multi-station machines are difficult, if not impossible to reconfigure, rearrange and/or expand into different or larger multi-stations.

SUMMARY OF THE INVENTION

[0005] A principle object of the present invention is to provide apparatus which is capable of being assembled and configured into any number of strength-training, exercise systems. More particularly, the invention concerns apparatus which can be formed into one or more readily customizable, and universally interchangeable, workout stations, which can either stand on their own or be attached to existing fixtures, such as previously purchased stand-alone exercise equipment or the fixtures, walls, etc. of an exercise room.

[0006] Still another object of the present invention is to provide user-defined exercise apparatus which may be configured into a multi-user workout station, as described above, which conveniently allows the attachment of a plurality of exercise devices of the same or different type while, in addition, can be used as a storage center for items normally found at a fitness center such as bands, weights, balls, bars, barbells, etc.

[0007] It is a still further object of the present invention to provide apparatus which may be configured into a user defined workout station and then later either reconfigured into another workout station or expanded into a larger multi-user station.

[0008] These objects, as well as further objects which will become apparent from the discussion that follows, are achieved, in accordance with the present invention, by providing a kit of parts which may be assembled and erected into exercise apparatus of various configurations, as desired and defined by the user.

[0009] As a minimum, this kit comprises the following elements:

[0010] (1) a plurality of frames adapted for substantially upright installation, each frame comprising two substantially identical elongate vertical members of a first prescribed length, each having two ends, which are connected together in parallel and in spaced-apart relationship by a horizontal crossbar of a second prescribed length adjacent each end, each of said vertical members having a plurality of points of attachment along its length; and

[0011] (2) at least one elongate horizontal member of a third prescribed length, each horizontal member adapted for connecting a separate one of the vertical members of a first frame with a corresponding one of the vertical members of a second frame, respectively, adjacent one of the upper and lower ends of the vertical members, thereby to form a supporting cell of frames.

[0012] The frames, which as a minimum have two vertical members connected in parallel relationship by the two crossbars, preferably comprise a large number of crossbars spaced equidistantly along the length of the vertical members, like rungs of a ladder to form a ladder-like structure.

[0013] Preferably also, the kit comprises a plurality of such horizontal members, enabling the user to assemble and connect two or more of the frames into various self-standing structures to form the supporting cell of frames. For example, two frames and two horizontal members may be connected in a Z-shaped configuration, with one horizontal member interconnecting two vertical members (one in each frame) near the top, and the other horizontal member interconnecting the same two vertical members near the bottom.

[0014] In another configuration, four horizontal members may connect two frames in a box-like or rectangular configuration to form a self-supporting cell.

[0015] In still further configurations, three or more frames may be interconnected to form a self-standing cell in the shape of a triangle, a pentagon, an octagon, etc.

[0016] The vertical and horizontal members included in the kit are all of a prescribed, standardized length. Advantageously, and in accordance with a further feature of the present invention, additional horizontal members may be provided that are all in a different, standardized length (either longer or shorter than the above-noted horizontal members). These additional horizontal members may be used for interconnecting frames or for connecting frames to a building structure, such as a wall. They may also be used to interconnect two or more self-supporting cells to form a larger, multi-user station.

[0017] As noted above, the vertical members in each frame have a plurality of points of attachment along their length. These facilitate the removable attachment of any one of a number of exercise devices to form a multi-user fitness workout station of virtually any desired design. In addition, once configured and assembled into a cell, the vertical members provide support for one or more storage devices, attached inside and/or outside the cell, permitting convenient storage of such items as bands, balls, bars, weights, etc.

[0018] The kit of standardized parts, according to the invention, offers a number of advantages over the exercise apparatus of the prior art.

[0019] 1. They eliminate the need, required for many items, to be attachable to a reinforced wall or other solid building surface. Such building structures are difficult to utilize for exercise equipment since drywall walls are inadequate for the support of such equipment and wall struts are not readily found.

[0020] 2. By replacing individual exercise machines or dedicated multi-user workstations with self-standing supporting cells, to which a large variety of exercise devices may be attached, the floor space normally required for a fitness center may be reduced to a relatively modest "foot-print" of one, or just a few, supporting cells.

[0021] 3. The exercise apparatus according to the invention is easily transportable. The supporting cell or cells may be easily disassembled and transported, together with their attachable exercise devices, to another location. The apparatus is ideal for military use, for example, since it can be transported and assembled in a tent.

[0022] 4. The exercise apparatus according to the invention is substantially less costly to manufacture, transport and install than the many individual exercise units or multi-station units known in the art. The single framework forming a supporting cell, according to the present invention, shares common parts onto itself, it allows the sharing of common parts, such as bars, weights, bands, etc., among the various exercise devices and, most importantly, it forms a common support structure for the attachment of one or more or a large variety of exercise devices. There is a substantial cost saving since these various exercise devices need not each have its own separate support structure.

[0023] 5. Last but not least, the exercise apparatus according to the invention eliminates most of the barriers disabled users face in using other machines which require frames and standing supports to hold them sturdy. These known structures almost always interfere with someone in a wheelchair. By offering a user-defined supporting framework that allows for virtually unlimited interchangeability of attachments, the invention allows users in wheelchairs to custom design their own equipment so that they can take advantage of the many fitness exercises that able-bodied persons also enjoy.

[0024] For a full understanding of the present invention, reference should now be made to the following detailed description of the preferred embodiments of the invention as illustrated in the accompanying drawings.

BRIEF DESCRIPTION OF THE DRAWINGS

[0025] FIG. 1 is a perspective view of a typical group of standardized parts which may form an assembly kit, according to the present invention, for erecting a supporting cell for exercise apparatus.

[0026] FIG. 2A is a perspective view of two frames connected in a Z-shaped configuration to form a supporting cell.

[0027] FIG. 2B is a perspective view of a single frame attached to a wall.

[0028] FIG. 3 is a perspective view of two frames connected in a rectangular configuration to form a supporting cell.

[0029] FIG. 4 is a perspective view of three frames connected in a pentagonal configuration to form a supporting cell.

[0030] FIG. 5 is a perspective view of two supporting cells of the type shown in FIG. 4 connected together to form a multiple-cell configuration.

[0031] FIGS. 6, 7 and 8 are perspective, side and top views, respectively, of the rectangular supporting cell of FIG. 3 with various exercise devices attached thereto.

[0032] FIGS. 9a and 9b are perspective and cross-sectional views, respectively, illustrating the preferred embodiment of the mode of attachment of an exercise device on a supporting cell.

[0033] FIG. 10 is a perspective view of an alternative embodiment of the mode of attachment of an exercise device on a supporting cell.

[0034] FIG. 11 is a perspective view of another alternative embodiment of the mode of attachment of an exercise device on a supporting cell.

[0035] FIG. 12 is a side view of the supporting cell of FIG. 3 incorporating a cable-operated exercise device and having another exercise device, called a "Kaplan Cell", arranged in front of it.

[0036] FIG. 13 is a side view of the supporting cell of FIG. 12 with the cable-operated exercise device incorporated therein.

[0037] FIG. 14 is a perspective view of the supporting cell of FIGS. 12 and 13.

[0038] FIG. 15 is a detailed perspective view of the Kaplan Cell shown in FIG. 12.

[0039] FIG. 16 is a perspective view of the supporting cell of FIG. 3, similar to that of FIGS. 6-8, with various other exercise and storage devices attached thereto.

[0040] FIG. 17 is a perspective view of two supporting cells of the type shown in FIG. 3, connected together side by side and supporting a large variety of exercise and storage devices.

DESCRIPTION OF THE PREFERRED EMBODIMENTS

[0041] The preferred embodiments of the present invention will now be described with reference to FIGS. 1-17 of the drawings. Identical elements in the various figures are designated with the same reference numerals.

[0042] FIG. 1 illustrates an assembly kit of standardized parts which can be used to erect exercise apparatus in any one of a number of different configurations, as will be explained below. In this particular instance, the kit includes two "frames" 10a and 10b each comprising two substantially identical vertical members 12 and 14 which are connected together at each end by round crossbars 16. Preferably, the frames 10 are provided with a greater number of these crossbars, interconnecting the vertical members, which are spaced equidistantly along the lengths of the vertical members like rungs of a ladder.

[0043] The vertical members 12 and 14 are each provided with holes, slots, hooks or the like equidistantly spaced along opposite sides, which serve as points of attachment for exercise devices, storage devices or other useful devices or things, when the respective frames are assembled in a workout space.

[0044] Advantageously, the frames 10 are also provided with adjustable feet 18 at the bottom of each vertical member, in the manner known in the art, permitting level adjustment of the frames on an uneven, or slanted floor.

[0045] Included in the kit are a plurality of bars 20a, 20b, 22a, 22b, 24a and 24b, in prescribed, standardized lengths for connecting the frames 10 together to form a self-standing "supporting cell" of frames for a workout station. The bars can also be used to connect a single frame to a building fixture or structure, such as a wall, or to connect multiple supporting cells together.

[0046] FIG. 2A illustrates how two frames 10a and 10b may be easily connected in a Z-shaped configuration using one of the horizontal bars 20a. The horizontal bar 20a is attached to the tops of two vertical members 14 and 12, respectively, of the frames 10a and 10b by bolts 21 which pass through the bar 20a and are screwed into threaded holes in the vertical members.

[0047] FIG. 2B shows how a single frame 10, comprising vertical members 12 and 14, may be affixed to a wall 15 by means of short horizontal bars 22a and 22b, attached at the tops of the vertical members 12 and 14 by bolts 21.

[0048] FIG. 3 illustrates a supporting cell 26 formed of kit parts 10a, 10b, 20a, 20b, 20c and 20d, connected together in a box-like configuration. The bars 20a, 20b, 20c and 20d are attached to the upper and lower extremities of the frames 10a and 10b, respectively, by means of bolts 21 which pass through the vertical members and are screwed into threaded holes at the ends of the bars 20.

[0049] FIG. 4 illustrates how three frames 10a, 10b and 10c can be joined together by horizontal bars 20a, 20b and 20c to form a pentagonal shaped supporting cell 28. As in the case of the configuration in FIG. 2, the horizontal bars 20 are bolted to the tops of the vertical members 12 and 14 of each frame.

[0050] FIG. 5 illustrates how two supporting cells, for example of the type 28 shown in FIG. 4, may be connected together by means of the horizontal bars 24a and 24b to form an expanded, double supporting cell.

[0051] As may be seen, a kit of parts of the type shown in FIG. 1 may be used to design and construct supporting cells of various sizes and shapes to form a basic unit for the attachment of one or more exercise devices. A particular example, illustrating the use of the supporting cell 26 of FIG. 3 to create customized exercise apparatus, will now be described with reference to FIGS. 6-9.

[0052] FIGS. 6-8 illustrate a supporting cell of the type 26 shown in FIG. 3 to which are attached a number of exercise devices. Attachment is by means of bolts which are screwed into threaded holes at the tops of the vertical frame members and by quick connections, which are illustrated in FIGS. 9a and 9b, that make use of the holes, or other attachment means, in the sides of each vertical member.

[0053] Shown in FIG. 6 are a horizontal ladder 30, attached to the tops of the frames 10a and 10b by bolts; a horizontal bar 32, also attached by bolts to the tops of the frames; a chin-up station or barbell holder 34; a combination squat rack/bench press/horizontal push-up station 36 and a so-called "dipping station" 38 comprised of two separately connected bars 38a and 38b.

[0054] The horizontal bar 32 may be used to support a hanging punching bag, boxing "speed bag" or other similar accessory.

[0055] Alternatively, or in addition, various other exercise devices may be removably attached to the supporting cell 26. As noted above in connection with FIG. 5, two or more supporting cells may be connected together to provide additional space for a larger variety of exercise devices.

[0056] Set forth below is a list of the common exercise devices which may be removably attached to one or more supporting cells. By providing a common structure for supporting these devices, the devices need not each have their own supporting structure, resulting in a substantial reduction in cost.

- [0057] (1) a bench press;
- [0058] (2) a barbell rack;
- [0059] (3) a weight rack;
- [0060] (4) a pair of balance beams;
- [0061] (5) a squat rack;
- [0062] (6) a calf block;
- [0063] (7) a leg rest;
- [0064] (8) a dip station;
- [0065] (9) a punching bag;
- [0066] (10) a horizontal ladder;
- [0067] (11) a horizontal chin-up bar;
- [0068] (12) a horizontal push-up bar;
- [0069] (13) a foot stand;
- [0070] (14) a connection device for elastic bands;
- [0071] (15) a cable pull device connected to a resistance means; and
- [0072] (16) a sliding bench.

[0073] Tipping of the supporting cell, and thus the entire structure, during use of the exercise devices is prevented by the addition of horizontal stabilizer bars 39a and 39b. These bars may be bolted directly to the frames 10a and 10b or to the interconnecting horizontal members 20c and 20d as shown.

[0074] FIGS. 10 and 11 illustrate alternative arrangements for removably attaching exercise devices to the vertical members 10a and 10b of a frame. In FIG. 10 the vertical members 10 are provided with spaced-apart slots; in FIG. 11, the vertical members 10 are provided with spaced-apart hooks for hanging the various devices.

[0075] FIGS. 12-14 show still another use of the supporting cell 26 of FIG. 3. In this case, the supporting cell is provided with two exercise devices, namely; (1) a cable-operated exercise device 40 for pulling a handle against an adjustable resistance, and (2) a so-called "Kaplan Cell" 50 with a large stability ball 51. As is best illustrated in FIG. 14, the cable-operated device 40 comprises two vertical members 41a and 41b attached top and bottom to the horizontal members 20a and 20c. Short crossbars 43a, 43b, 43c and 43d serve to interconnect the vertical members 41a and 41b to the horizontal members 20a and 20c, forming a U-shaped

structure within the supporting cell. The crossbars **43** support two vertical rods **42a** and **42b** which, in turn, serve as rails for a moveable carriage **44**. This carriage is connected to the distal ends of two cables **47a** and **47b** (shown in dashed lines in FIG. **13**) that may be pulled by a user to raise the carriage **44** upward against the force of the resistance. The means of resistance may be a weight stack (not shown), from which the user may select one or more weights, one or more elastic bands (shown in FIG. **14** as springs **49a** and **49b** attached to a hook rack) and one or more hydraulic or pneumatic dampers (not shown), or a combination of these.

[0076] The Kaplan Cell **50** is shown in detail in FIG. **15**. This Cell, which may be attached to the base of the supporting cell **26**, comprises two foot pads **52a** and **52b** as well as two foot bolsters **54a** and **54b**, for use when the person sits either on an accompanying seat or is supported by the ball **51**. Cable extensions **47c** and **47d** may be clipped onto the proximal ends of the cables **47a** and **47b**, respectively, to permit the user to exercise in the sitting position by pulling the cables in a "rowing" motion.

[0077] FIG. **16** illustrates the rectangular supporting cell **26** with a further variety of exercise devices attached thereto. These devices include a heavy punching bag **70**, a boxing "speed ball" **72**, a dip station **74** and a squat rack **76**. In addition, the supporting cell serves as a storage unit **78** for various items such as medicine balls, weights, elastic bands and the like.

[0078] FIG. **17** illustrates how an arrangement of the type shown in FIG. **16** may be expanded to include still further exercise devices, as desired. In this case, two supporting cells **26** are connected together by horizontal bars to accommodate the addition of a Kaplan Cell **50** and also a second type of cable-operated resistance device **80** as well as a sliding bench **82**. The cable-operated device **80**, which allows a user to pull one or both of two cables from any one of number of points along an arc, is fully disclosed in my co-pending U.S. patent application Ser. No. 11/408,213, filed Apr. 20, 2006, which application is incorporated herein by reference.

[0079] There has thus been shown and described a novel user-defined exercise apparatus which fulfills all the objects and advantages sought therefor. Many changes, modifications, variations and other uses and applications of the subject invention will, however, become apparent to those skilled in the art after considering this specification and the accompanying drawings which disclose the preferred embodiments thereof. All such changes, modifications, variations and other uses and applications which do not depart from the spirit and scope of the invention are deemed to be covered by the invention, which is to be limited only by the claims which follow.

What is claimed is:

1. An assembly kit of standardized parts for erecting exercise apparatus in any one of a number of different configurations, as desired and selected by a user, said kit comprising, in combination:

- (1) at least one frame adapted for substantially upright installation and comprising two substantially identical elongate vertical members of a first prescribed length, each having two ends, which are connected together in parallel and in spaced-apart relationship by a horizontal

crossbar of a second prescribed length adjacent each end, each of said vertical members having a plurality of points of attachment along its length;

- (2) at least one elongate first horizontal member of a third prescribed length, each first horizontal member adapted for connecting a separate one of the vertical members of a first frame to a wall or to a corresponding one of the vertical members of a second frame, respectively, adjacent one of the upper and lower ends of said vertical members, thereby to form a supporting cell; and
- (3) at least one exercise device having means for removable attachment to one or more members of said supporting cell, attachment to a vertical member being at one of said plurality of points of attachment;

wherein the parts may be connected together on a site of a place of exercise to provide said supporting cell for attachment of said at least one exercise device.

2. The kit of parts recited in claim 1, further comprising an instruction manual illustrating and describing a method of assembling the parts of the kit together.

3. The kit of parts recited in claim 1, wherein said vertical members each have a plurality of holes at prescribed positions along its length to provide the points of attachment, and wherein a plurality of said exercise devices each have at least one prong for insertion in a selected one of said holes in at least one of said vertical members, thereby to retain and support said exercise device at said point of attachment.

4. The kit of parts recited in claim 1, wherein said vertical members each have a plurality of hooks extending outward at prescribed positions along its length to provide the points of attachment, and wherein a plurality of said exercise devices each have at least one means for attachment to a selected one of said hooks in at least one of said vertical members, thereby to retain and support said exercise device at said point of attachment.

5. The kit of parts recited in claim 1, comprising at least two pairs of said first horizontal members of said third prescribed length, adapted for interconnecting the vertical members of the first frame and second frame, respectively, adjacent both the upper and lower ends of said vertical members, to form said supporting cell.

6. The kit of parts recited in claim 1, wherein said frame has a plurality of said crossbars interconnecting said vertical members, said crossbars being spaced substantially equidistantly along the lengths of the vertical members like rungs of a ladder.

7. The kit of parts recited in claim 1, further comprising a sufficient number of frames and first horizontal members to form at least one additional supporting cell, when assembled, and at least one pair of elongate second horizontal members of a fourth prescribed length that is longer than said third prescribed length, each pair of second horizontal members being adapted for connecting a separate one of the vertical members of a first supporting cell with a corresponding one of the vertical members of a second supporting cell, respectively, adjacent one of the upper and lower ends of said vertical members, thereby to connect said supporting cells together.

8. The kit of parts recited in claim 1, wherein said at least one exercise device is selected from the group consisting of:

- (1) a bench press;
- (2) a barbell rack;
- (3) a weight rack;
- (4) a pair of balance beams;
- (5) a squat rack;
- (6) a calf block;
- (7) a leg rest;
- (8) a dip station;
- (9) a punching bag;
- (10) a horizontal ladder;
- (11) a horizontal chin-up bar;
- (12) a horizontal push-up bar;
- (13) a foot stand;
- (14) a connection device for elastic bands;
- (15) a cable pull device connected to a resistance means; and
- (16) a sliding bench.

9. The kit of parts recited in claim 8, wherein said resistance means is selected from the group consisting of at least one of a weight stack, at least one elastic band and at least one damper.

10. The kit of parts recited in claim 1, wherein said vertical members each have a vertical hole in the top for attachment of a horizontal member.

11. The kit of parts recited in claim 1, comprising one frame and at least two horizontal members for connecting the frame to a wall to form said supporting cell.

12. The kit of parts recited in claim 1, comprising at least two frames and at least one first horizontal member adapted to connect the two frames in a Z-shaped configuration to form said supporting cell.

13. The kit of parts recited in claim 1, comprising at least two frames and at least two first horizontal members adapted to connect the two frames in a rectangular configuration to form said supporting cell.

14. The kit of parts recited in claim 1, comprising at least three frames and at least three first horizontal members adapted connect the three frames in a pentagonal shape to form said supporting cell.

15. The kit of parts recited in claim 1, further comprising at least one third elongate horizontal member having a fifth prescribed length which, when attached to a lower part of a supporting cell, serves as a stabilizer bar to prevent said supporting cell from tipping over.

16. Exercise apparatus for supporting selected ones of a plurality of separate exercise devices and permitting simultaneous use of the apparatus by a plurality of persons, said apparatus comprising, in combination:

- (a) a free standing, rectangular frame structure comprising:
 - (1) a first ladder formed of a pair of elongate vertical frame members arranged in parallel and connected

together in spaced apart relationship by a first plurality of horizontal rungs spaced substantially equidistant from each other;

- (2) a second ladder formed of a pair of elongate vertical frame members arranged in parallel and connected together in spaced apart relationship by a second plurality of horizontal rungs spaced substantially equidistant from each other;
 - (3) a first pair of horizontal frame members, each connecting a separate one of the vertical frame members of said first ladder with a corresponding one of the vertical frame members of said second ladder, respectively, at a first level adjacent the lower extremities of said vertical frame members; and
 - (4) a second pair of horizontal frame members, each connecting a separate one of the vertical frame members of said first ladder with a corresponding one of the vertical frame members of said second ladder, respectively, at a second level adjacent the upper extremities of said vertical frame members; and
- (b) at least one exercise device having means for removable attachment to said frame structure.

17. The exercise apparatus recited in claim 16, wherein said at least one exercise device is selected from the group consisting of:

- (1) a bench press;
- (2) a barbell rack;
- (3) a weight rack;
- (4) a pair of balance beams;
- (5) a squat rack;
- (6) a calf block;
- (7) a leg rest;
- (8) a dip station;
- (9) a punching bag;
- (10) a horizontal ladder;
- (11) a horizontal chin-up bar;
- (12) a horizontal push-up bar;
- (13) a foot stand;
- (14) a connection device for elastic bands;
- (15) a cable pull device connected to a resistance means; and
- (16) a sliding bench.

18. The apparatus recited in claim 17, wherein said resistance means is selected from the group consisting of a weight stack, an elastic band and a damper.

19. The apparatus recited in claim 16, wherein the vertical frame members each have a plurality of holes extending horizontally therethrough, said holes being spaced apart equidistantly along the length of each frame member for accepting pegs for attachment of said exercise devices.