



EUROPEAN PATENT APPLICATION

Application number : **91309653.3**

Int. Cl.⁵ : **B21F 27/10, B21F 27/12**

Date of filing : **18.10.91**

Priority : **25.10.90 FI 905267**

Inventor : **Myllymäki, Erkki**
Vastarannankatu 49 A
SF-33610 Tampere (FI)

Date of publication of application :
29.04.92 Bulletin 92/18

Representative : **Leale, Robin George**
FRANK B. DEHN & CO. Imperial House 15-19
Kingsway
London WC2B 6UZ (GB)

Designated Contracting States :
AT BE CH DE DK FR GB IT LI NL SE

Applicant : **TAMMER ELEMENTTI OY**
Mäkirinteentie 13
SF-36220 Kangasala (FI)

Method and equipment for automatic production of reinforcing steels for concrete elements.

A method and an equipment for automatic production of reinforcements for concrete elements. In the method, a reinforcing steel (18) is cut into portions (9a, 9b) such that an empty space is left within the area of an opening designed in the finished concrete element. The reinforcing steel portions (9a, 9b) to be positioned in line with each other are displaced in place simultaneously with a mutual spacing corresponding to the opening. The equipment comprises dimensioning means for automatically cutting the reinforcing steel so that the reinforcing steel is positioned only outside an opening designed in the concrete element, and displacing means (8, 11) for displacing reinforcing steel portions (9a, 9b) to be positioned at a certain point simultaneously in place.

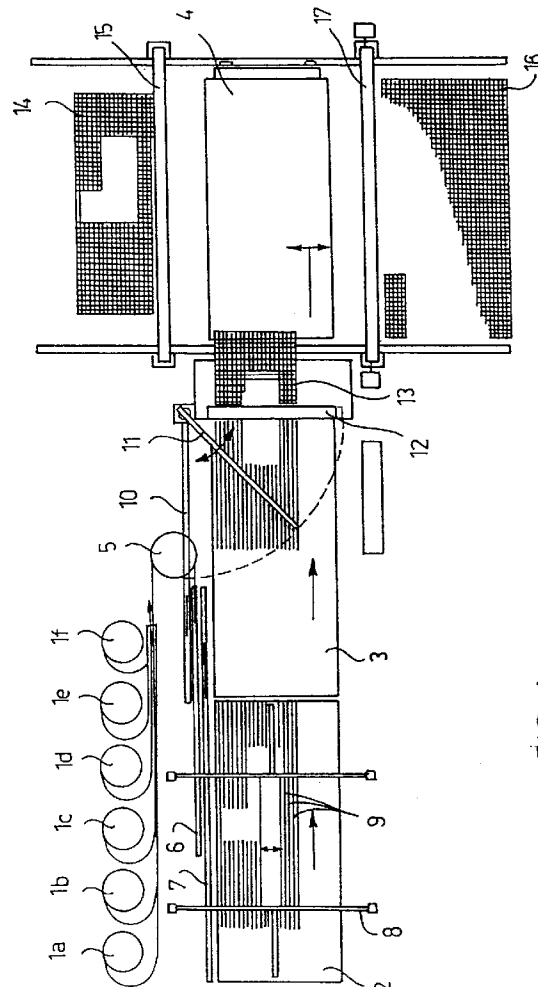

FIG. 1

The invention relates to a method of automatically producing reinforcements for concrete elements, in which method a reinforcing steel needed for the production of the reinforcement is fed from a reel and straightened, whereafter the straightened reinforcing steel is cut into desired lengths, longitudinal reinforcing steels for the reinforcement are positioned side by side and reinforcing steels transverse to the longitudinal reinforcing steels are displaced one at a time upon the longitudinal reinforcing steels and the longitudinal and transverse reinforcing steels are welded together at the intersections after each displacement of a transverse reinforcing steel.

The invention is also concerned with an equipment for automatically producing reinforcements for concrete elements, comprising at least one reel for reinforcing steel, straightening and cutting means for straightening the reinforcing steel fed from one of the reels and for cutting the straightened reinforcing steel into desired lengths, and means for positioning reinforcing steels both longitudinally and transversely of the reinforcement, and welding means for welding together the longitudinal and transverse reinforcing steels at their intersections.

The production of concrete elements is automated and mechanized to a great extent, whereas the production of reinforcements is still largely carried out manually with little automation or mechanization. For automatic production of reinforcements, various equipments have been constructed which form a continuous mesh so that the finished reinforcement is a mesh-like product. Such an reinforcement is known e.g. from US Patent 3,405,743, in which reinforcing steels extending longitudinally of the reinforcement are positioned in a retainer provided with grooves and transverse reinforcing steels are then welded to the longitudinal reinforcing steels one at a time, and so a mesh-like rectangular reinforcement is obtained. Furthermore, SE Published Specification 344417 discloses an equipment in which the longitudinal reinforcing steels of the reinforcement are fed from reels through straightening means all side by side, and one transverse reinforcing steel at a time is similarly fed from a reel through the straightening means upon the longitudinal reinforcing steels and welded to the longitudinal reinforcing steels, and then the longitudinal reinforcing steels are moved onwards and a new transverse reinforcing steel is fed upon them.

The known equipments described above have the drawback that the reinforcement is throughout in the form of a mesh, and so the reinforcement in the area of the openings of the concrete element always has to be cut off separately. A concrete element often comprises various window and door openings and openings for ventilation, electricity, and so on. These openings are left empty in connection with the casting of the element, and reinforcement within such areas hampers the construction and use of casting moulds.

In addition to extra work, this involves a waste of material and time. In addition, the strength of the reinforcements and the reinforcing steel thicknesses always have to be dimensioned according to the maximum values, whereby thick reinforcements are used even in cases where a thinner reinforcement would be sufficient in view of the strength requirements. In the above-mentioned US Patent, the reinforcements have to be brought to the construction site as finished rods of final dimensions, which makes the handling difficult and requires plenty of room. A problem with the equipment of the above-mentioned SE Published Specification, in turn, is that it requires as many reels as longitudinal reinforcing steels, whereby the mesh density of the reinforcement is always constant and cannot be changed as required.

The object of the present invention is to provide a method and an equipment for automatic welding of reinforcements, which avoid the above drawbacks and provide reinforcements with openings for concrete elements of different shapes and comprising openings of different kinds. The reinforcements can be shaped suitably and may comprise, if required, reinforcing steels of different lengths and thicknesses so that a reinforcing steel of suitable thickness can be selected according to the strength requirements. The method according to the invention is characterized in that the longitudinal and transverse reinforcing steels of the reinforcement are fed one at a time, and in order to provide empty spaces for openings to be formed in the finished concrete element, the reinforcing steel is cut only into such lengths as required for the area of reinforcement outside the opening, and that all reinforcing steel portions to be positioned in line with each other are displaced in position simultaneously.

The equipment according to the invention is characterized in that it comprises means for automatically dimensioning and cutting off reinforcing steel portions intended for a predetermined area in the reinforcement in such a way that the reinforcement is formed only outside an opening to be formed in a concrete element, and that the means for positioning the reinforcing steel portions comprise a displacing means for displacing reinforcing steel portions to be positioned in line with each other in the reinforcement simultaneously to the right position.

The basic idea of embodiments of the invention is that reinforcing steel to be positioned at a certain point or on a certain line is cut into portions such that empty spaces are left within the area of the openings of the concrete element, whereby the reinforcing steel portions to be positioned in line with each other are displaced after cutting simultaneously to their right position, and so an opening of a predetermined shape in both the longitudinal and transverse direction is formed at a desired point in the reinforcement. In this way, the reinforcement can be produced automatically without any extra cutting step.

Certain embodiments of the invention will now be described, by way of example only with reference to the accompanying drawings in which Figure 1 illustrates schematically an equipment; and

Figure 2 is a schematic, more detailed view of the formation of a reinforcing steel.

Figure 1 shows a reinforcing equipment comprising reels 1a to 1f for reinforcing steels. Concrete reinforcing steels of different thicknesses are wound on the reels, and so a reinforcing steel of required thickness can be selected for use. As used in the specification and claims of this patent application, the term *reinforcing steel* refers to profiled, wire-like steel which may be smooth, profiled or deformed in cross-section and which is used in a well-known manner for reinforcing concrete products. The equipment further comprises transporting means 2, 3 and 4 positioned one after another. Reinforcing steel from one of the reels 1a to 1f is passed through a straightening apparatus 5, whereafter it extends in parallel with the direction of travel of the transporting means 2 to 4 of the welding apparatus. It is then cut into portions in such a way that the portions to be positioned in line with each other on both sides of an opening to be formed in the reinforcement are positioned in a corresponding order one after another. Thereafter the reinforcing steel or its portions are displaced from a displacing means 6 provided in connection with the cutting apparatus to a displacing means 7 for longitudinal reinforcement elements, in which they are set out with the same mutual spacings as those between the reinforcing steels in the finished product, and then they are displaced by means of a displacing means 8 to the right position of the longitudinal reinforcing steels 9 on the transporting means 2. After all the longitudinal reinforcing steels 9 have been positioned in place, they are displaced by means of the transporting means 2 and 3 onwards to the transporting means 3, whereafter the positioning of transverse reinforcing steels is started. The first transverse reinforcing steel is positioned at the forward end of the longitudinal reinforcing steels 9, and similarly as the longitudinal reinforcing steels, the transverse reinforcing steel is straightened in the straightening apparatus 5 and cut into predetermined dimensions onto the displacing means 6 of the cutting apparatus, and it usually extends over the entire width of the reinforcement. The transverse reinforcing steels are then displaced onto a displacing means 10, whereon they are positioned in the longitudinal direction of the reinforcement with mutual spacings corresponding to their final positions. Thereafter all reinforcing steel portions to be positioned in line with each other are displaced upon the longitudinal reinforcing steels 9 by turning with a turning apparatus 11 and are welded to them by means of a welding apparatus 12. After the transverse reinforcing steels 13 and the longitudinal reinforcing steels 9 have been welded together at the

intersections, the reinforcement is displaced onwards by means of the transport means 3 in such a way that the following transverse reinforcing steel 13 or all reinforcing steel portions to be positioned in line with each other are welded at the right position. In this way, the reinforcement can be designed optimally by using mainly a reinforcing steel of a predetermined thickness, while a thicker reinforcing steel can be used within the areas of the edges of openings to increase the strength of the structure, if required. Accordingly, the entire reinforcement need not be dimensioned in accordance with the greatest load, but it can be adjusted according to the load at each point. The reinforcement is gradually displaced onto the displacing or transporting means 4 until it is completed, and then a reinforcement with openings or the like is displaced by means of a displacing means 15 into a pile 14 of reinforcements of different sizes, and a conventional reinforcement is displaced into a pile 16 of reinforcements by means of a displacing means 17.

Figures 2a to 2c show schematically the formation of reinforcing steel portions to be positioned at a certain point in the concrete reinforcement. In Figure 2a, a reinforcing steel 18 is passed from the right to the displacing means 6 of the cutting apparatus, whereby it is cut into reinforcing steel portions 9a and 9b of predetermined dimensions by means of the cutting apparatus 5 in accordance with the openings to be made in the concrete element. Thereafter the reinforcing steel portions, in this specific case, the portions 9a and 9b of the longitudinal reinforcing steel 9, are displaced onto the displacing means 7 shown in Figure 2a in such a way that a distance corresponding to the opening to be made in the concrete element remains between the portions, as shown in Figure 2b. Thereafter the portions 9a and 9b are gripped by means of the displacing means 8 and they are displaced simultaneously onto a support surface formed by the transport means 2, and so there will be no reinforcing steels in the area of the openings of the concrete element, indicated by a rectangle drawn by broken lines in Figure 2c. The reinforcing steels or reinforcing steel portions are formed similarly for each particular area of the reinforcement, and all the reinforcing steel portions 9a and 9b are displaced simultaneously so that they are positioned appropriately. In this way, the formation of reinforcements is simple and easy even for concrete elements containing such complicated openings as shown in Figure 1 on the transporting means 2. The transverse reinforcing steels are also formed and cut and displaced in position similarly as shown in Figures 2a-2c, that is, reinforcing steel portions to be positioned in line with each other are displaced simultaneously in position with proper lengths and spacings, whereby the openings required by the elements are formed also in the transverse direction.

An embodiment of the invention has been des-

cribed and shown in the above description and the attached drawings by way of example, and it is in no way restricted to this example. The structure and operation of the displacing mechanism and the displacing means of the cutting apparatus may vary, provided that the reinforcing steels can be positioned appropriately with the right mutual spacings before they are displaced in position. In place of the turning displacing means shown in Figure 1, the transverse reinforcing steels can be displaced in position and shaped by means of a displacing means in which the reinforcing steel is transversely positioned and is cut into suitable dimensions and positioned appropriately. The choice of the thickness of the reinforcing steels at different points of the reinforcement and in accordance with the strength requirements of the reinforcement can be made in many different ways. Furthermore, separate straightening and displacing means can be provided for longitudinal and transverse reinforcing steels, in which case it is possible to position the longitudinal and transverse reinforcing steels simultaneously, which speeds up the production. As used in the specification and claims of this patent application, the longitudinal and transverse directions refer to the directions in the production process described, and they are not restricted to the directions of the reinforcing steels in the concrete element. Accordingly, the longitudinal reinforcing steels may be transversely positioned in the finished element or vertically positioned in a wall element, and correspondingly, the transverse reinforcing steels may extend in the longitudinal direction in the finished element.

Claims

1. A method of automatically producing reinforcements for concrete elements, in which method a reinforcing steel (18) needed for the production of the reinforcement is fed from a reel (1a to 1f) and straightened, whereafter the straightened reinforcing steel (18) is cut into desired lengths, longitudinal reinforcing steels (9) for the reinforcement are positioned side by side and reinforcing steels (13) transverse to the longitudinal reinforcing steels are displaced one at a time upon the longitudinal reinforcing steels and the longitudinal and transverse reinforcing steels (9, 13) are welded together at the intersections after each displacement of a transverse reinforcing steel (13), **characterized** in that the longitudinal and transverse reinforcing steels (9) of the reinforcement are fed one at a time, and in order to provide empty spaces for openings to be formed in the finished concrete element, the reinforcing steel (18) is cut only into such lengths as required for the area of reinforcement outside the opening, and that all reinforcing steel portions (9a, 9b) to be positioned in line with each other are displaced in position simultaneously.
2. A method according to claim 1, **characterized** in that the longitudinal and transverse reinforcing steels (9, 13) of the reinforcement are fed from the same reinforcing steel reels (1a to 1f).
3. A method according to claim 2, **characterized** in that the reinforcing steel is straightened so that it extends in parallel with the direction of the displacing movement of transporting means (2, 3), that the longitudinal reinforcing steels (9) are displaced in a direction transverse to the direction of the displacing movement of the transporting means to the right position, and that the transverse reinforcing steels (13) are displaced in position by turning them from said direction about a vertical axis transversely upon the longitudinal reinforcing steels.
4. An equipment for automatically producing reinforcements for concrete elements, comprising at least one reel (1a to 1f) for reinforcing steel (18), straightening and cutting means (5) for straightening the reinforcing steel (18) fed from one of the reels (1a to 1f) and for cutting the straightened reinforcing steel (18) into desired lengths, and means (6 to 8, 10, 11) for positioning reinforcing steels (9, 13) both longitudinally and transversely of the reinforcement, and welding means (12) for welding together the longitudinal and transverse reinforcing steels (9, 13) at their intersections, **characterized** in that it comprises means for automatically dimensioning and cutting off reinforcing steel portions (9a, 9b) intended for a predetermined area in the reinforcement in such a way that the reinforcement is formed only outside an opening to be formed in a concrete element, and that the means for positioning the reinforcing steel portions (9a, 9b) comprise a displacing means (8) for displacing reinforcing steel portions (9a, 9b) to be positioned in line with each other in the reinforcement simultaneously to the right position.
5. An equipment according to claim 4, **characterized** in that it comprises several reels (1a to 1f) each for a reinforcing steels (18) of different thickness, whereby a reinforcing steel (18) of desired thickness can be selected and fed to the straightening and cutting means (5).
6. An equipment according to claim 4 or 5, **characterized** in that both the longitudinal and the transverse reinforcing steels (9, 13) are fed from the same reels (1a to 1f) through the same straighten-

ing and cutting means (5) so that they extend in parallel with the direction of travel of the transporting means (2, 3) of the equipment, that the means for positioning the reinforcing steels (9, 13) comprise a displacing means (11) mounted turnably about a vertical axis for turning the transverse reinforcing steel portions (13) upon the longitudinal reinforcing steels (9).

5

10

15

20

25

30

35

40

45

50

55

5

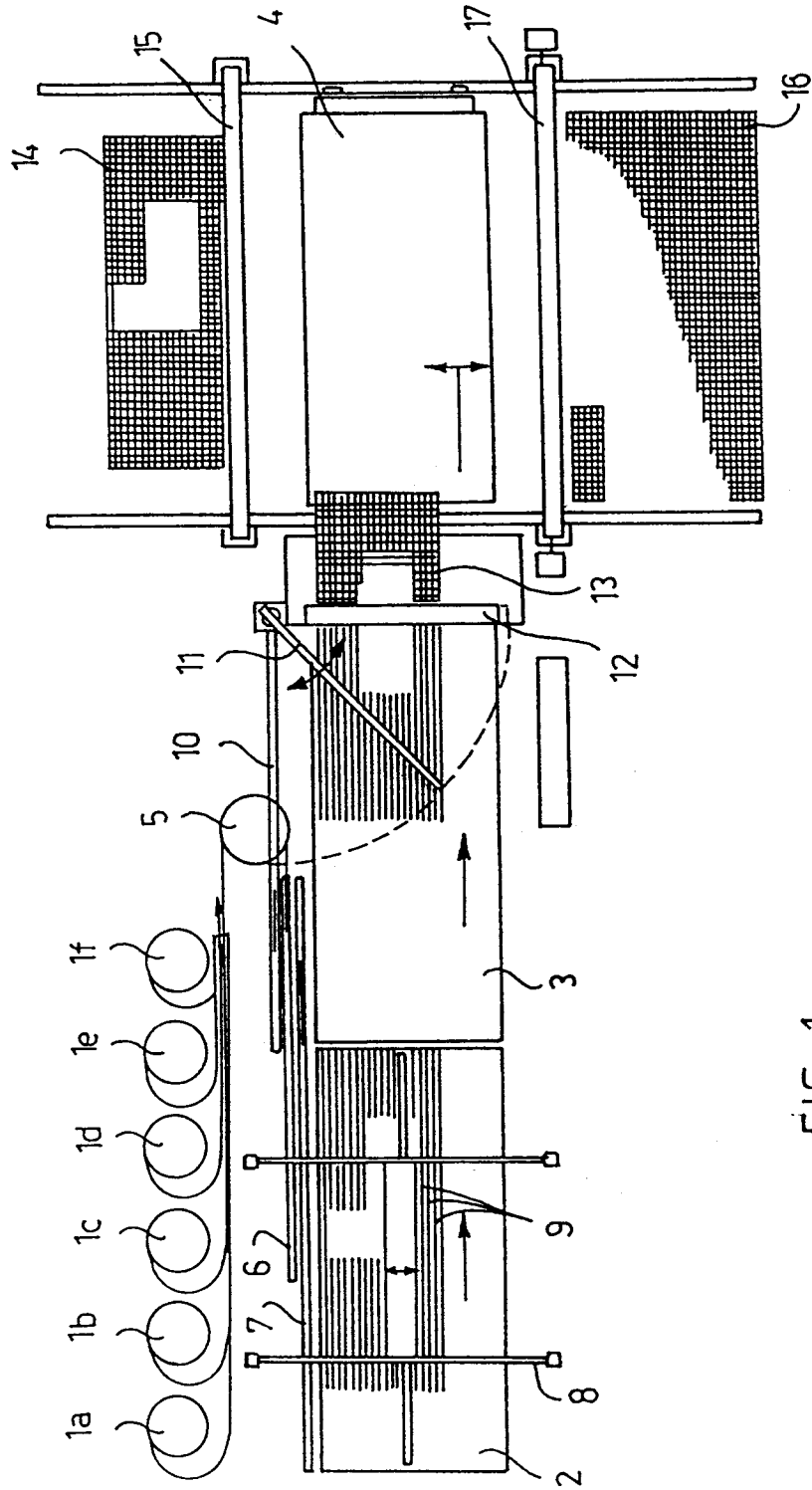

FIG. 1

FIG. 2a

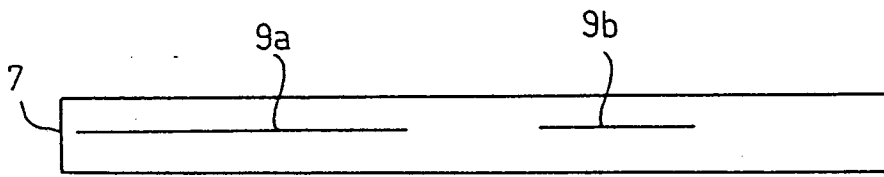
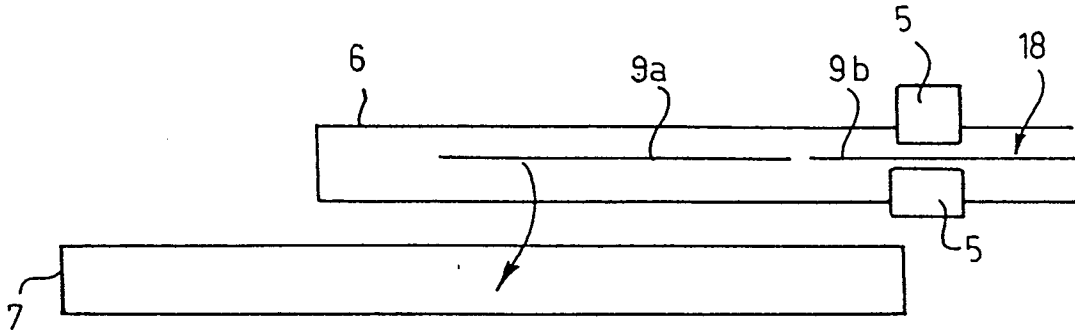

FIG. 2b

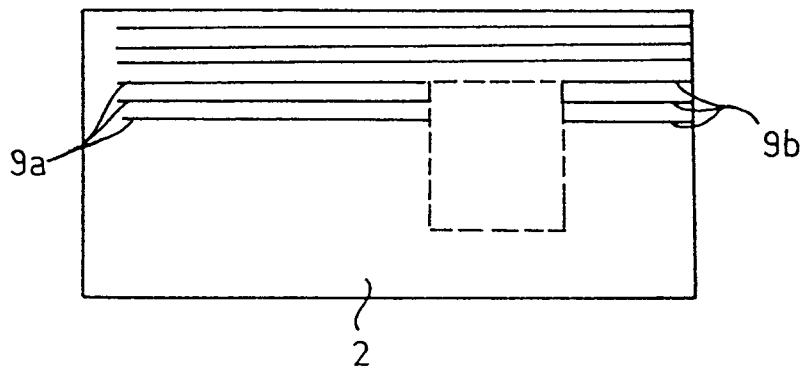

FIG. 2c



European Patent
Office

EUROPEAN SEARCH REPORT

Application Number

EP 91 30 9653

DOCUMENTS CONSIDERED TO BE RELEVANT			
Category	Citation of document with indication, where appropriate, of relevant passages	Relevant to claim	CLASSIFICATION OF THE APPLICATION (Int. Cl.5)
Y	EP-A-0 125 716 (DECOUX) * page 5, line 5 - line 30; claim 1; figure 1 *	1, 3, 4	B21F27/10 B21F27/12
A	---	5, 6	
Y	WELDING AND METAL FABRICATION vol. 49, no. 2, March 1981, SUSSEX GB pages 77 - 79; D. A. BOWMAN: 'MESH WELDING AT HIGH RATES AND TO NON-STANDARD PATTERNS' * page 79, right column; figure 5 *	1, 3, 4	
A	---	5	
A	FR-A-1 215 087 (REIMBERT) ---		
D,A	US-A-3 405 743 (ROBINSON) -----		
The present search report has been drawn up for all claims			TECHNICAL FIELDS SEARCHED (Int. Cl.5)
			B21F B23K
Place of search	Date of completion of the search	Examiner	
THE HAGUE	31 JANUARY 1992	PLASTIRAS D.	
CATEGORY OF CITED DOCUMENTS		T : theory or principle underlying the invention E : earlier patent document, but published on, or after the filing date D : document cited in the application L : document cited for other reasons & : member of the same patent family, corresponding document	
X : particularly relevant if taken alone Y : particularly relevant if combined with another document of the same category A : technological background O : non-written disclosure P : intermediate document			

EPO FORM 1503 03.82 (P0401)