



US 20110108586A1

(19) **United States**

(12) **Patent Application Publication**
Diamond et al.

(10) **Pub. No.: US 2011/0108586 A1**

(43) **Pub. Date: May 12, 2011**

(54) **NESTABLE HANGER WITH ARTICULATING INTEGRATED HOOK**

Publication Classification

(76) Inventors: **Aaron Diamond**, Hollis Hills, NY (US); **Robert Doherty**, Northport, NY (US)

(51) **Int. Cl.**
A41D 27/22 (2006.01)

(52) **U.S. Cl.** **223/85**

(21) Appl. No.: **13/008,970**

(57) **ABSTRACT**

(22) Filed: **Jan. 19, 2011**

Related U.S. Application Data

(63) Continuation-in-part of application No. 12/182,351, filed on Jul. 30, 2008.

A hanger is disclosed having a hanger supporting means in the form of an articulating integrated hook for supporting additional hangers therefrom, wherein the hook may be inserted into the body of its hanger to facilitate the nesting of one hanger with the other like hanger.

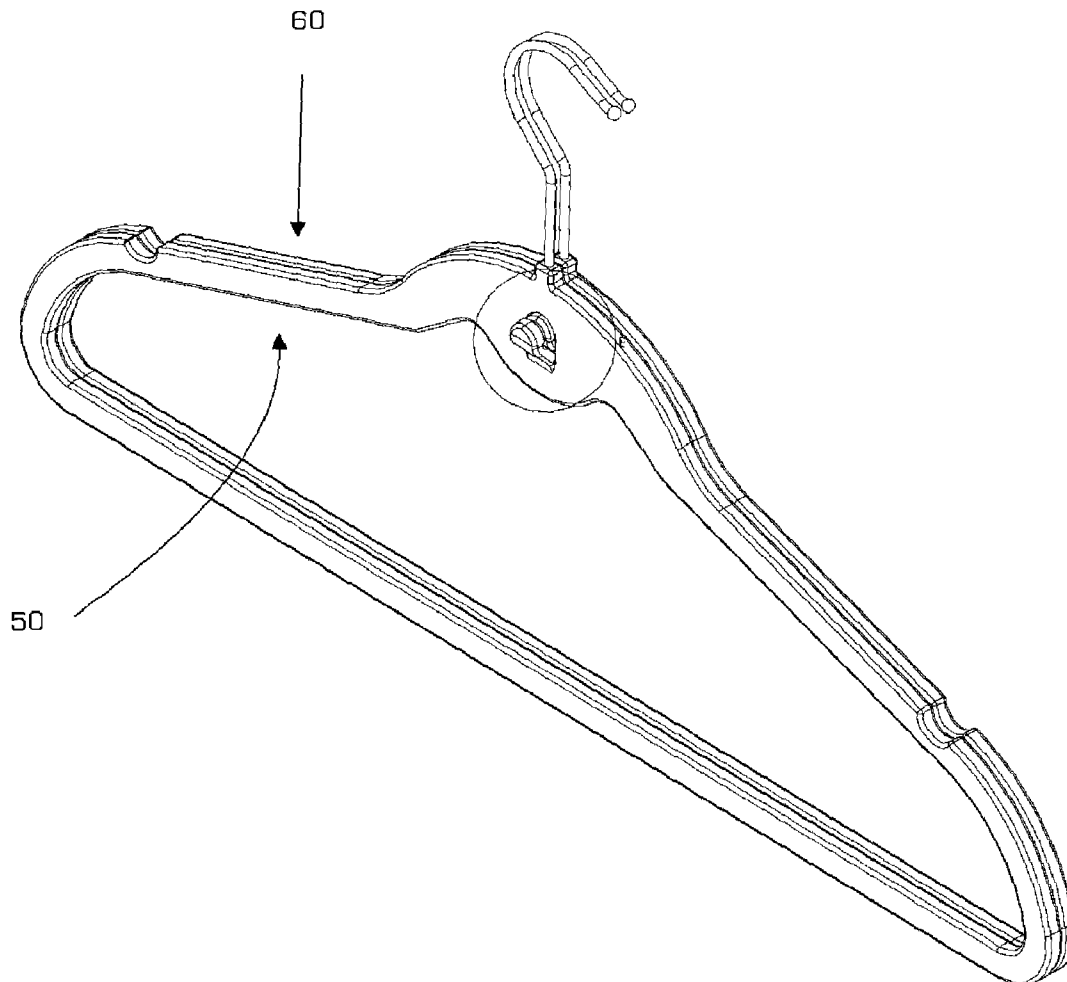

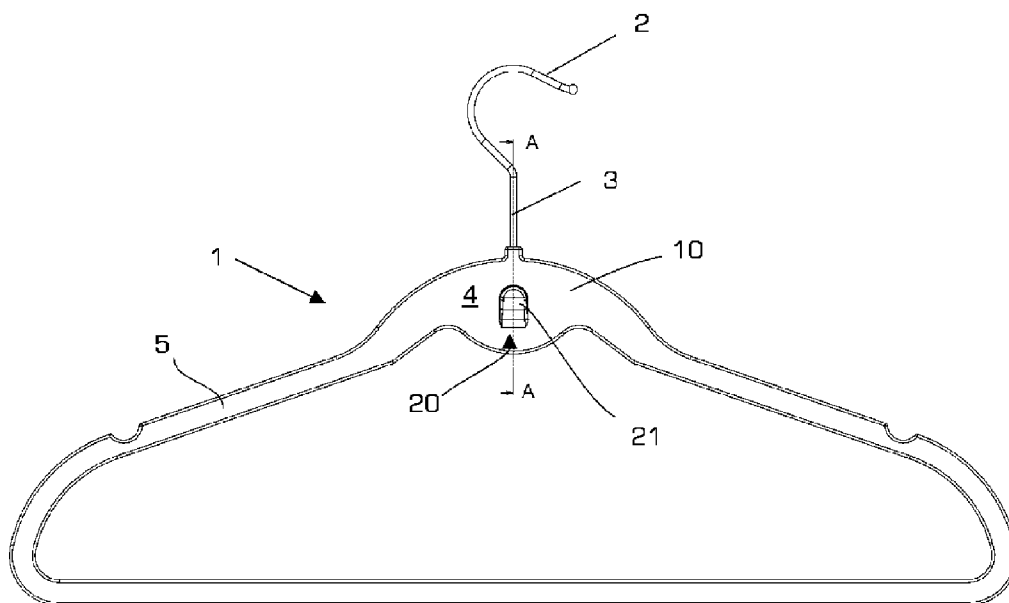

Fig. 1

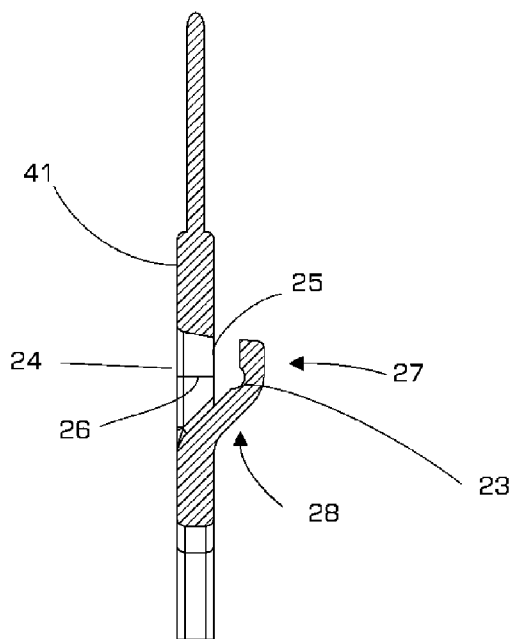

Fig. 2

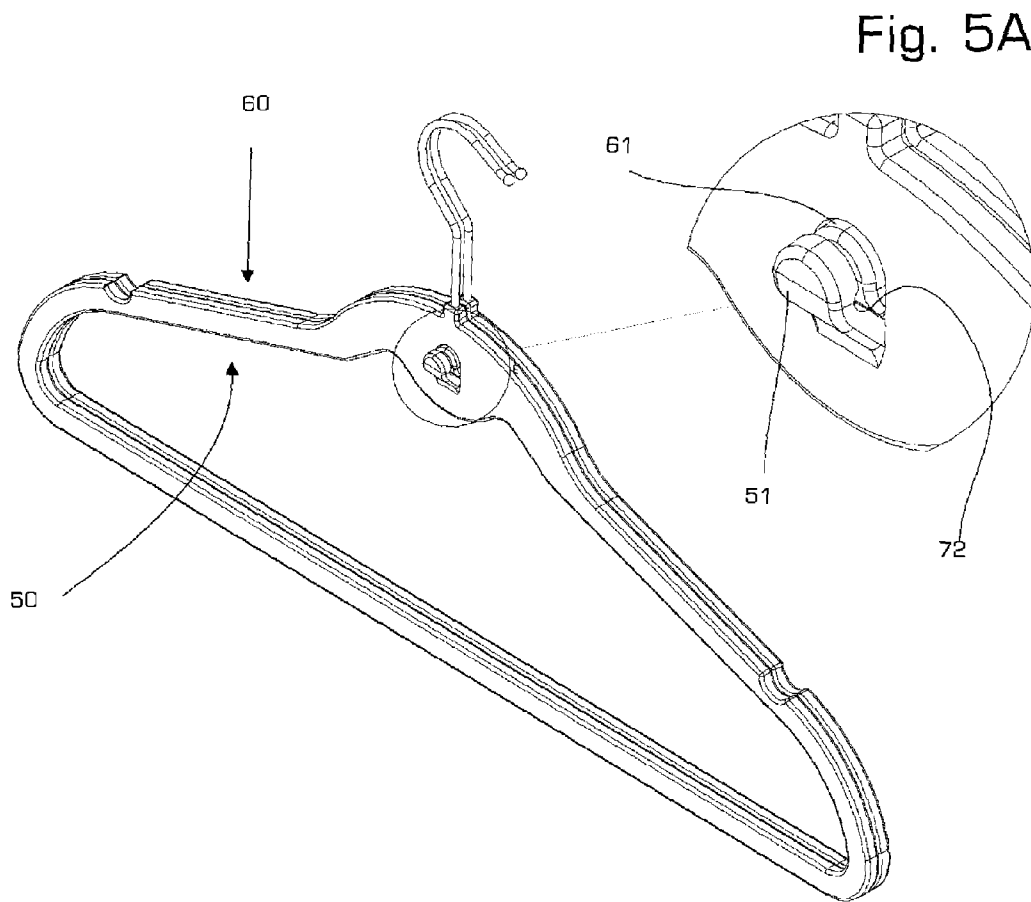

Fig. 5

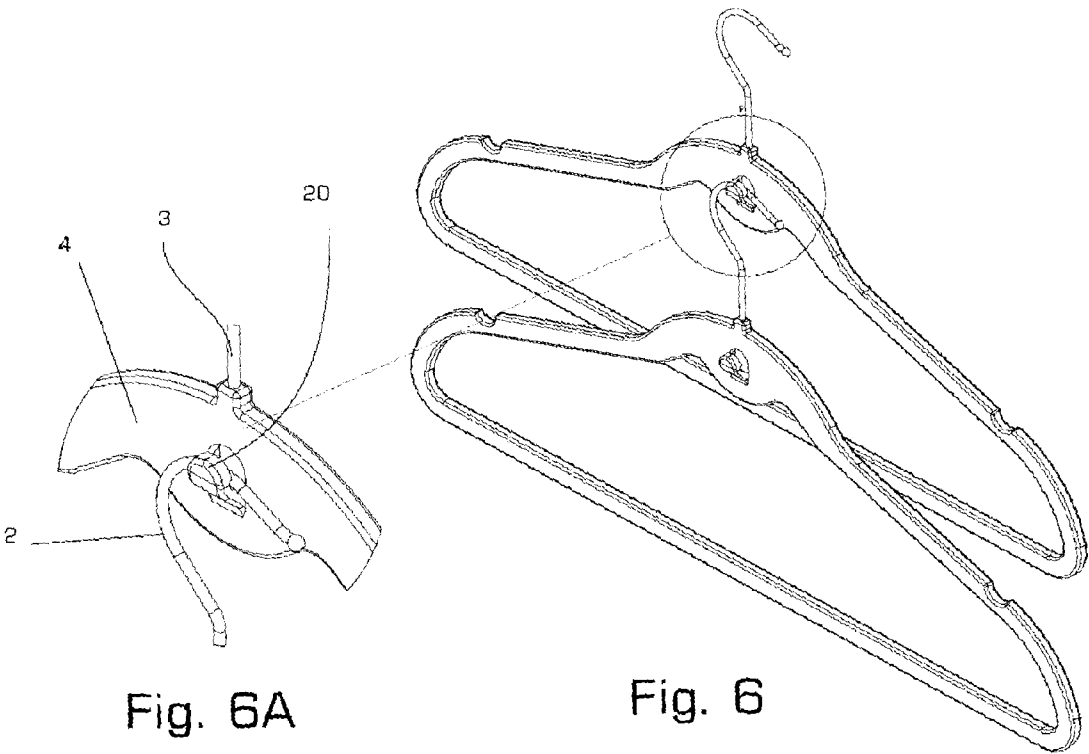

Fig. 6A

Fig. 6

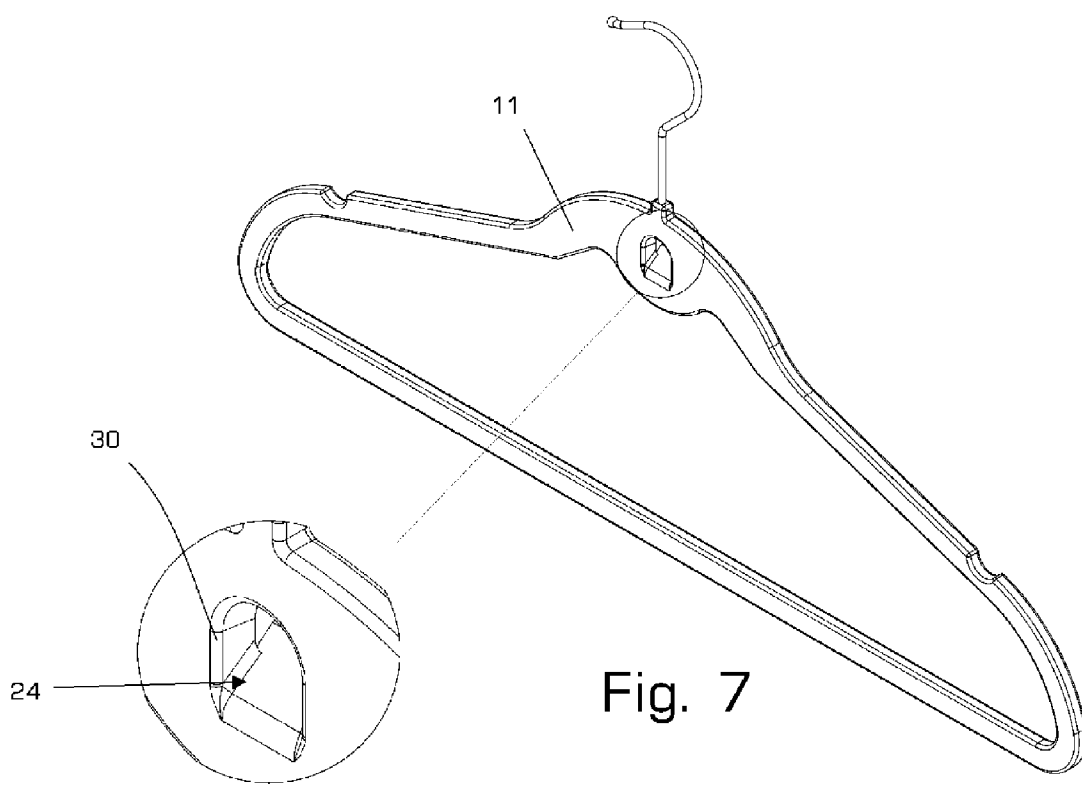

Fig. 7A

Fig. 7

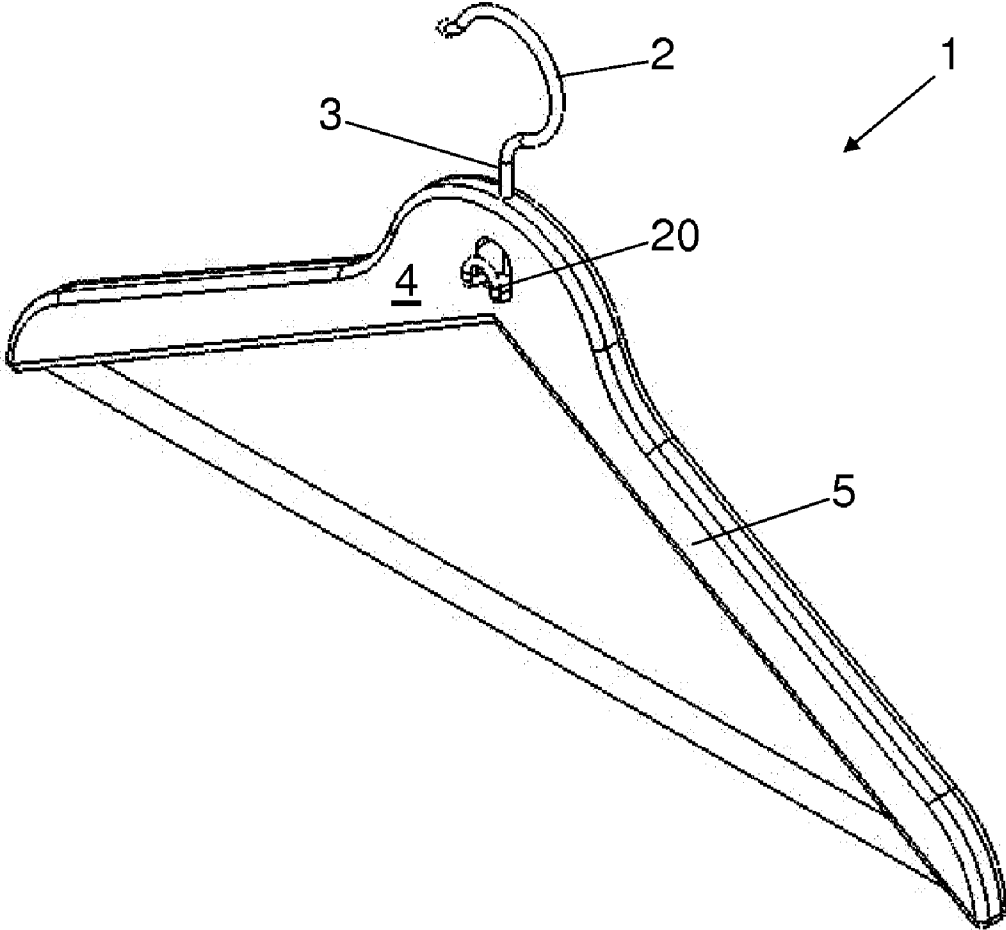

Figure 8

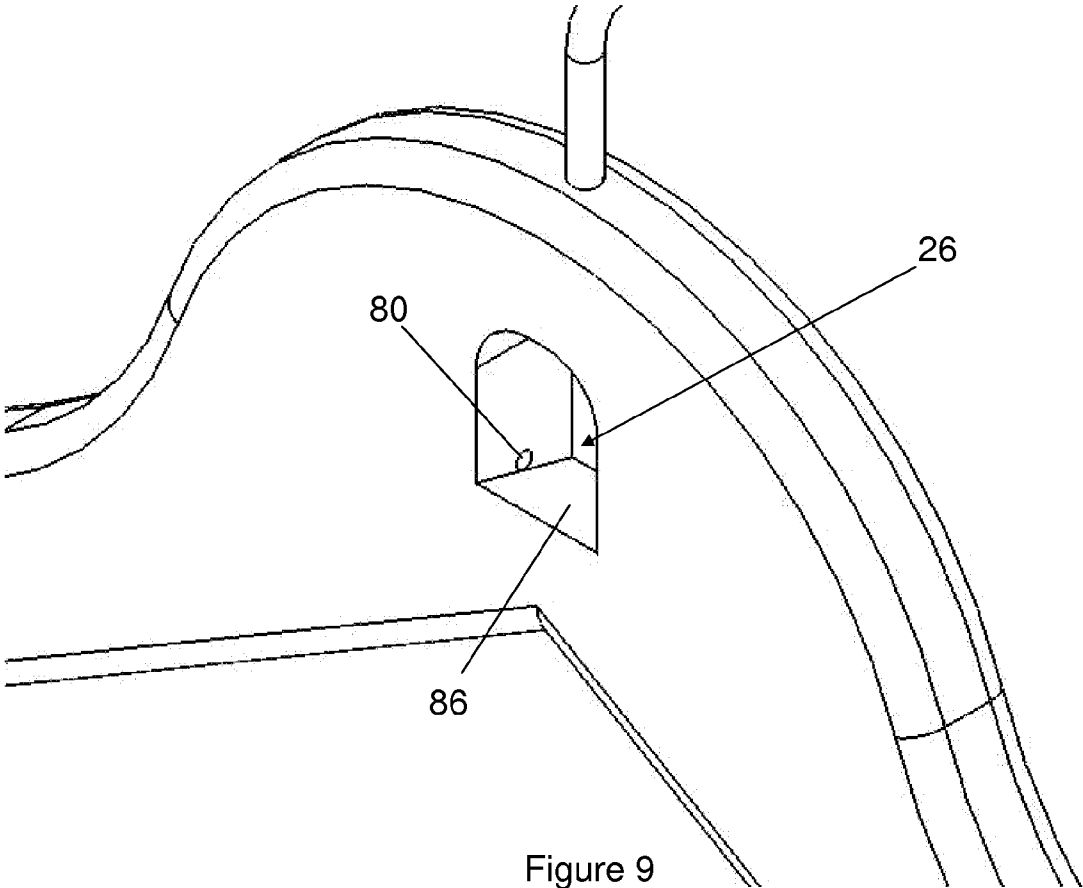

Figure 9

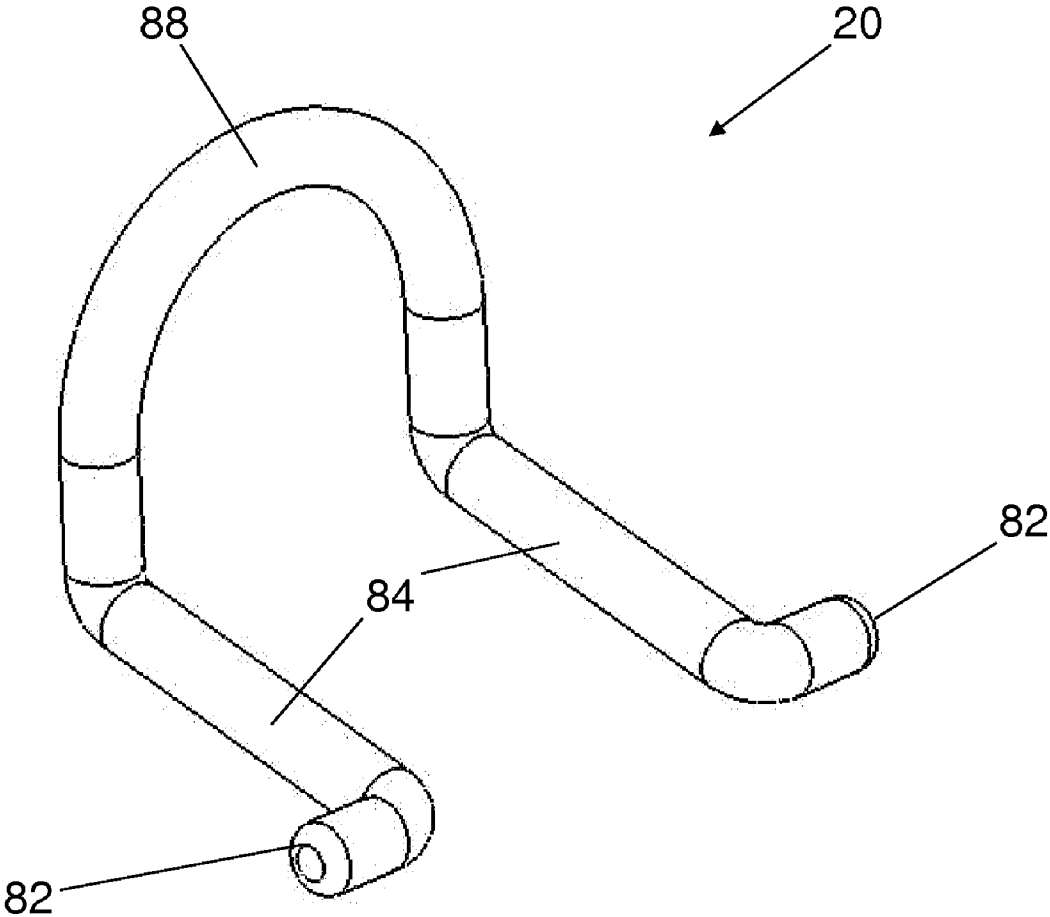

Figure 10

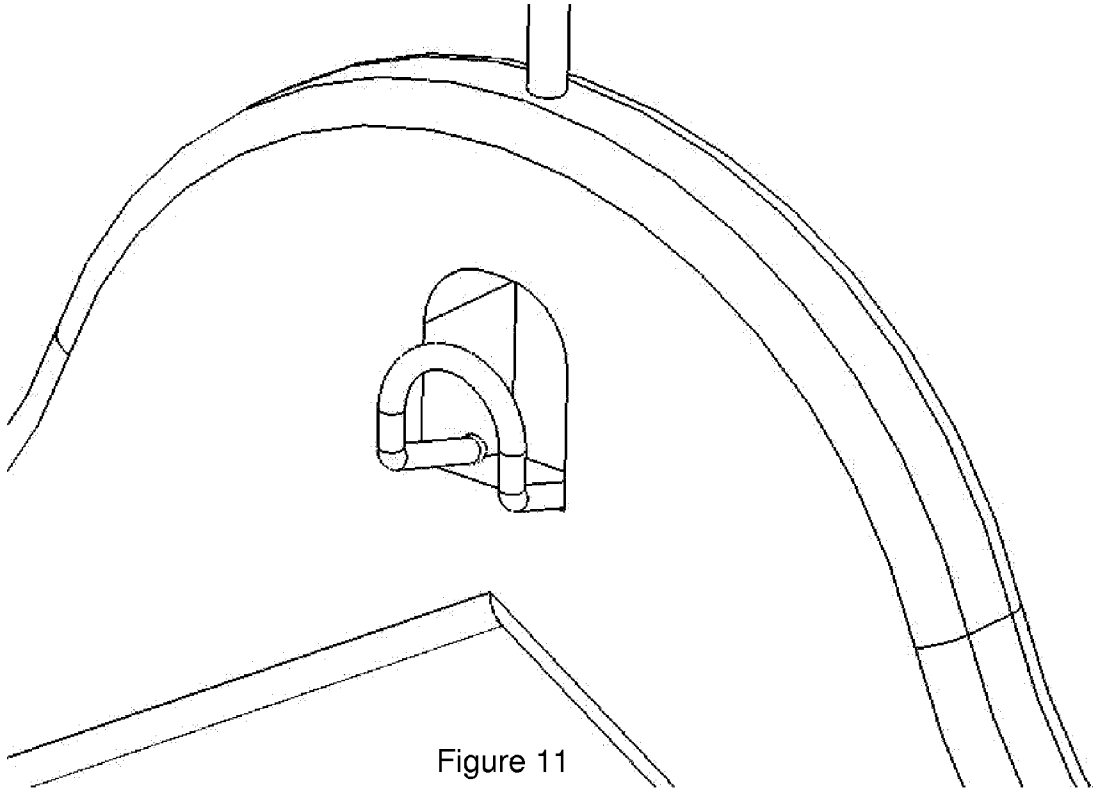

Figure 11

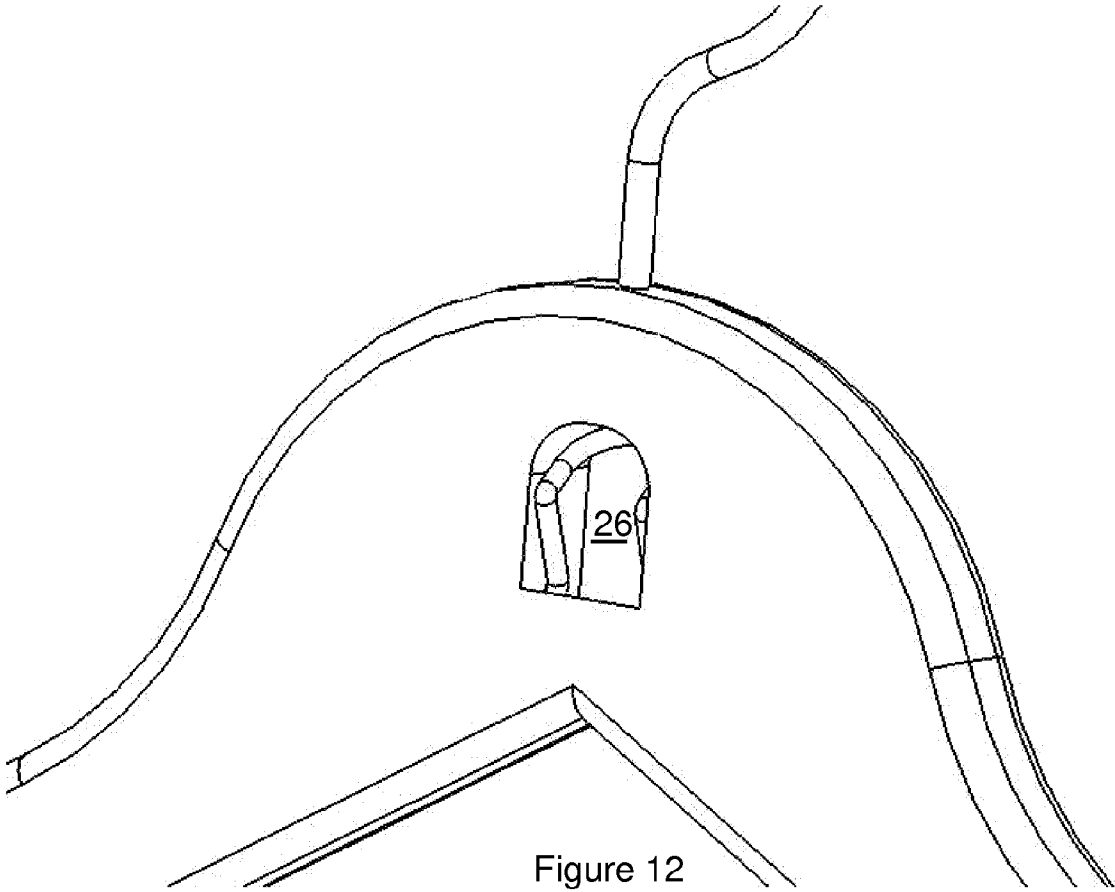

Figure 12

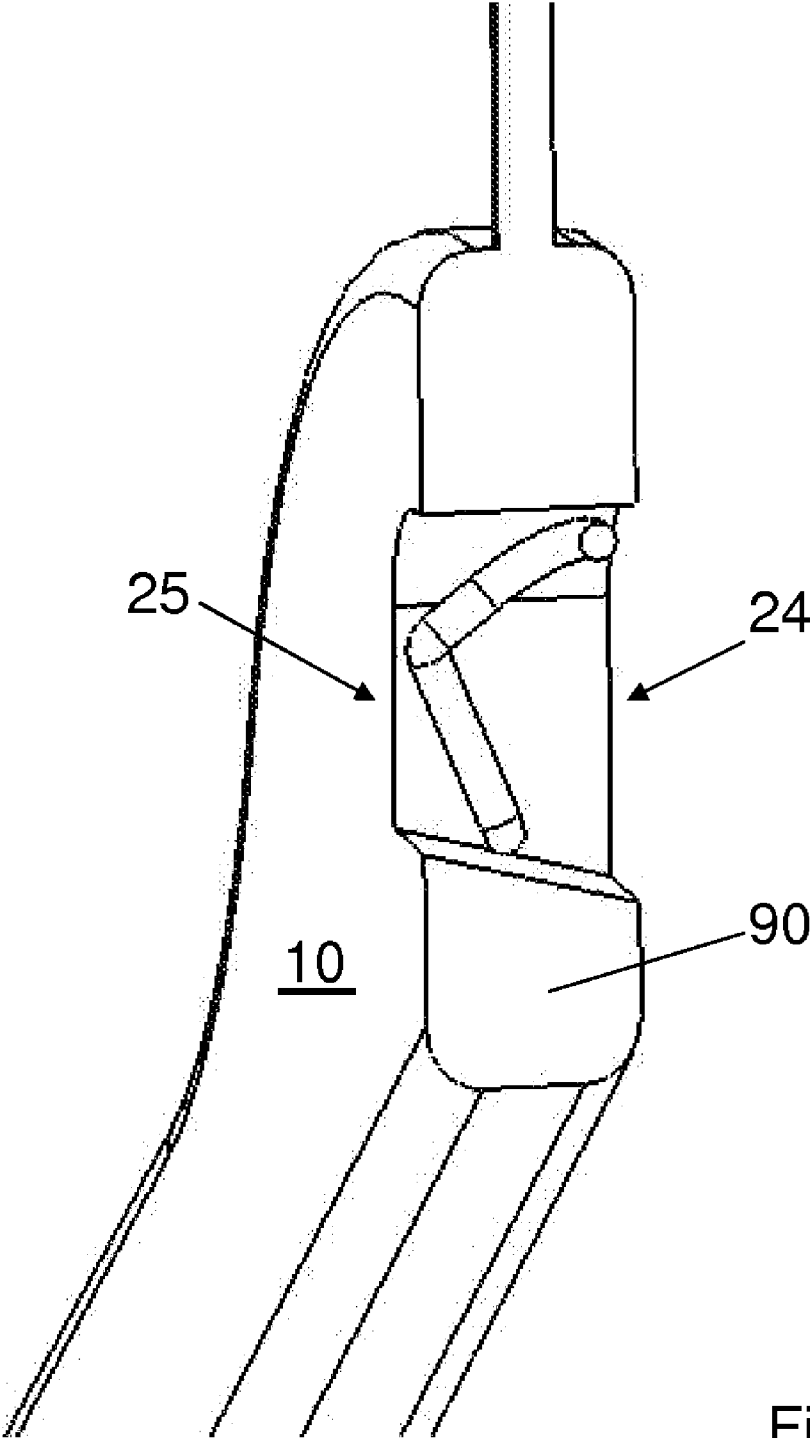

Figure 12A

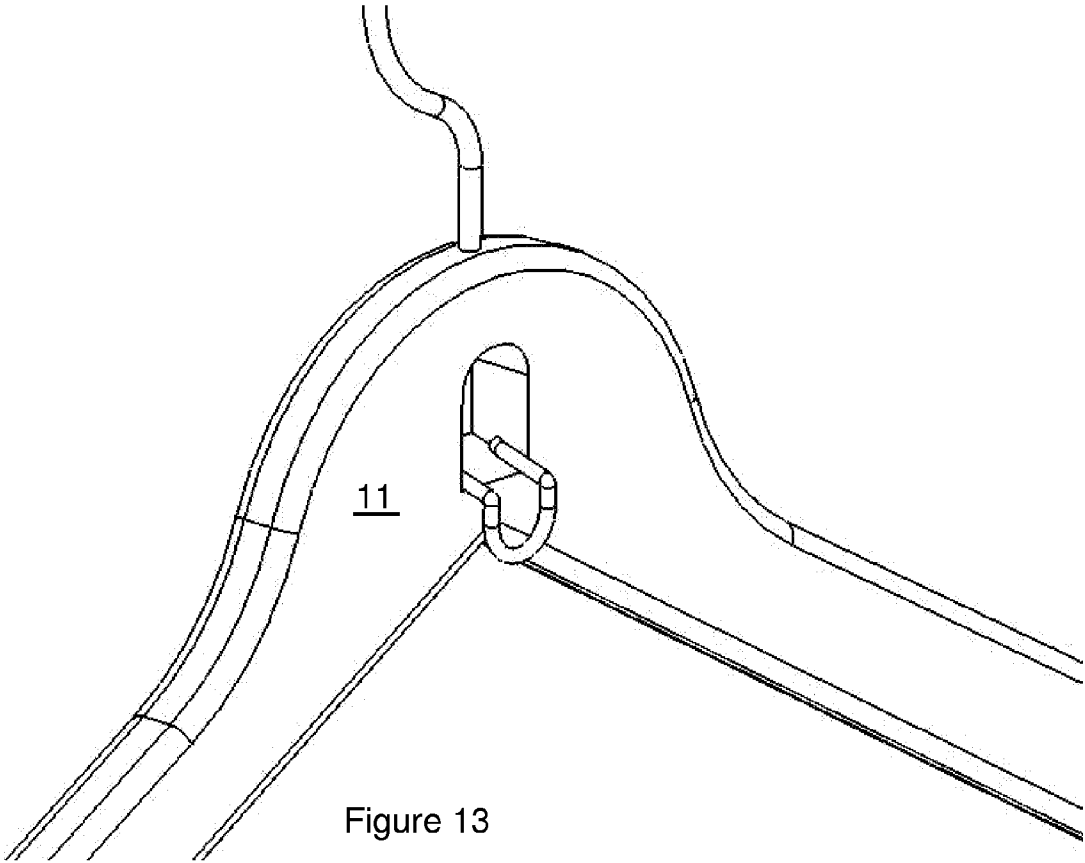

Figure 13

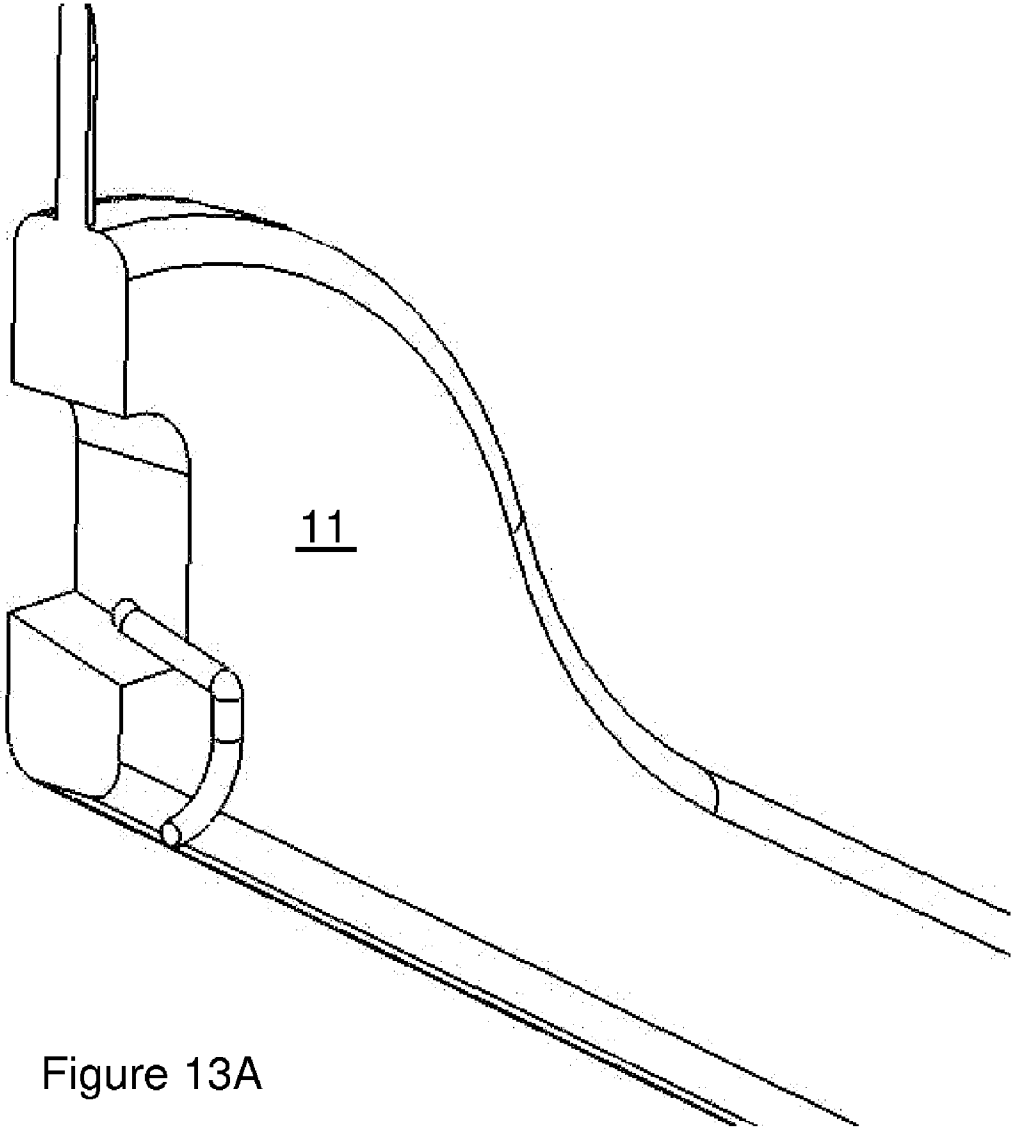

Figure 13A

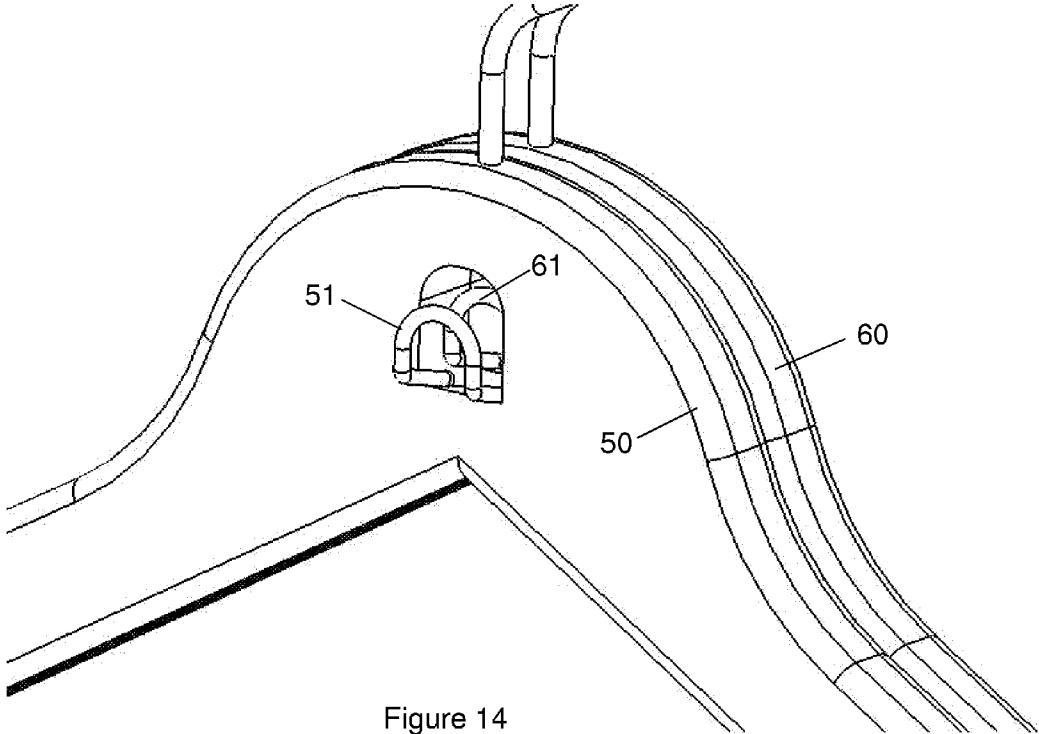

Figure 14

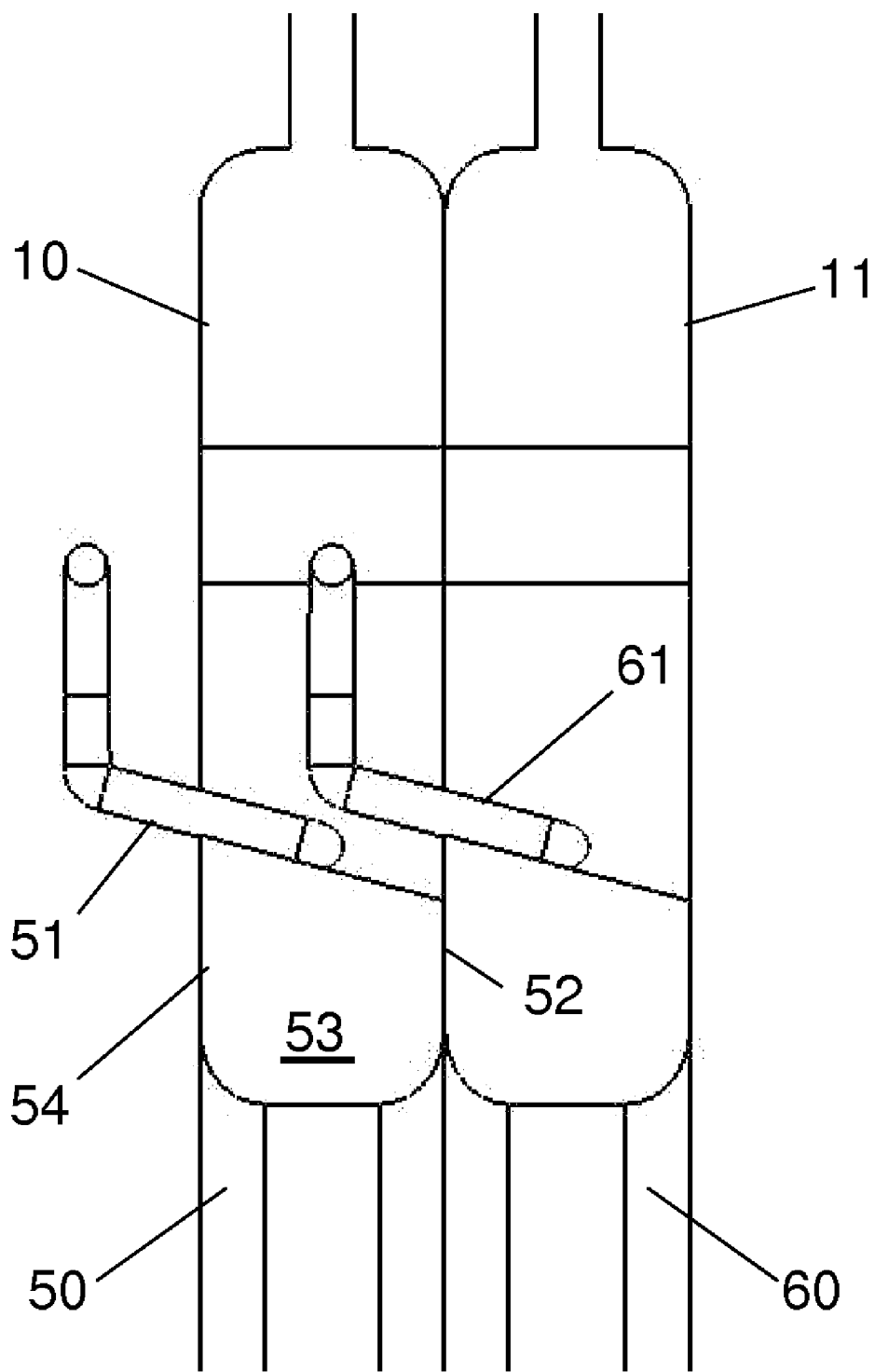

Figure 14A

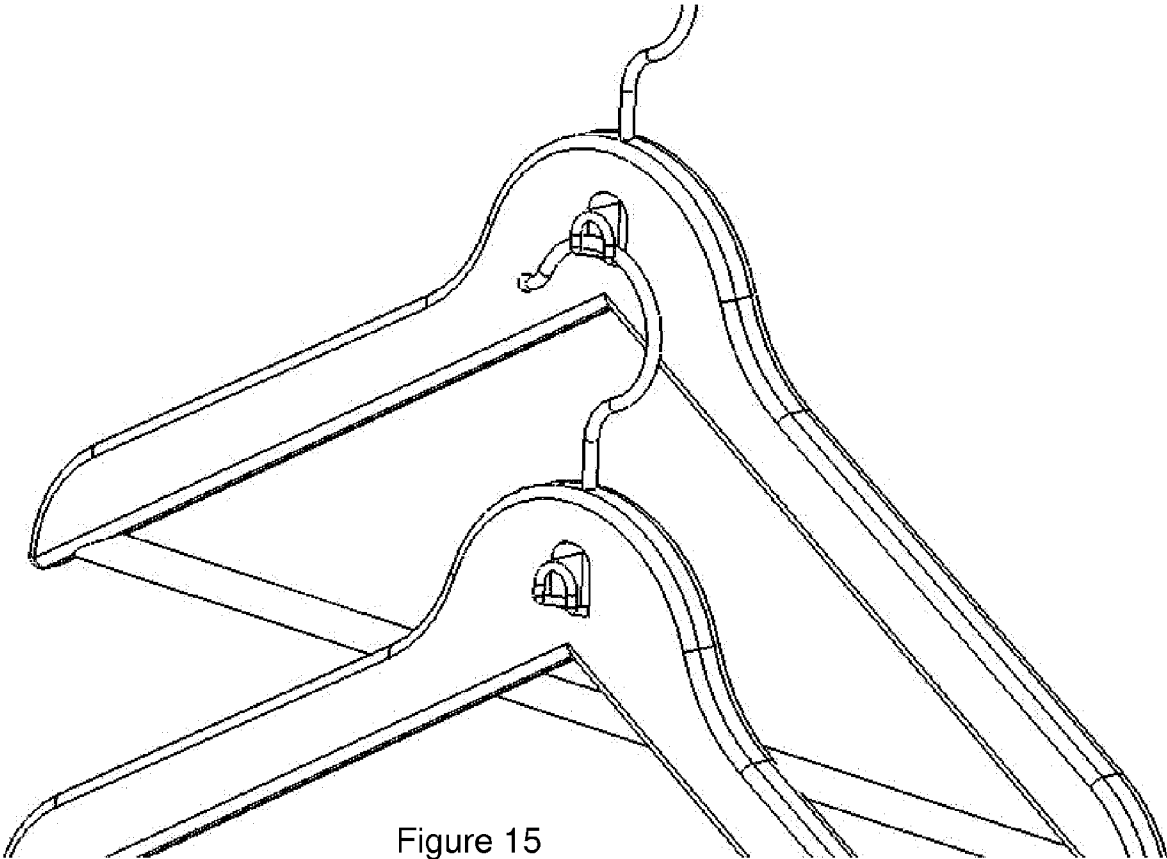

Figure 15

NESTABLE HANGER WITH ARTICULATING INTEGRATED HOOK

CROSS REFERENCE TO RELATED APPLICATIONS

[0001] This application is a continuation-in-part and claims the benefit of U.S. Ser. No. 12/182,351, filed on Jul. 30, 2008, entitled Nestable Hangar With Integrated Cascade Hook, which is incorporated in its entirety herein by reference.

BACKGROUND OF THE INVENTION

[0002] 1. Field of the Invention

[0003] The present invention generally relates to the field of clothing hangers and in particular to the field of nestable hangers having hanger supporting means for supporting additional hangers therefrom. Specifically, the present invention pertains to a clothing hanger that includes an articulating hook for attaching an additional hanger thereto. By having such functionality, a clothing hanger can both add additional hangers and be stored in a nested fashion thereby using a minimal amount of storage.

[0004] 2. Description of the Related Art

[0005] Hangers having nestable configurations are disclosed in the prior art, as are hangers having hanger supporting means for supporting additional hangers therefrom.

[0006] One example of a hanger having hanger supporting means for supporting additional hangers therefrom may be found, for instance, in U.S. Pat. No. 4,653,678 to Blanchard et al., which discloses a “ganging hook” via which additional hangers may be supported. The “ganging hook” disclosed in Blanchard et al. extends downwardly from the hanger body. The “ganging hook” of Blanchard et al. does not provide any nesting functionality to the hanger.

[0007] Another example of a hanger having supporting means for supporting additional hangers therefrom is U.S. Pat. No. 4,871,098 to Bredeweg et al. The hanger disclosed in Bredeweg et al. discloses a “hook socket for ganging hangers.” As with Blanchard et al., the “hook socket” of the hanger disclosed in Bredeweg et al. extends downwardly from hanger body and does not provide any nesting functionality.

[0008] U.S. Pat. No. 5,074,445 to Chen discloses a garment hanger with a “ganging hook” extending from the hanger body. The position of the “ganging hook” of Chen impedes nesting of hangers.

[0009] Similarly, U.S. Pat. No. 5,803,321 to Willinger et al. discloses a hanger having “ganging element” extending downwardly from the hanger body. As with the previously cited prior art, the “ganging element” of the hanger disclosed in Willinger et al. does not promote nesting of hangers. Like hangers may also be found in U.S. Pat. Nos. 6,070,772 to Bond; 6,105,834 to Cohen; 6,308,872 to Duerr et al.; and 6,467,658 to Olk et al.

[0010] None of the foregoing prior art discloses hangers with hanger supporting means for supporting additional hangers therefrom configured in such a manner so as to allow for nesting of hangers. It is therefore desirable to have a hanger which not only includes hanger supporting means for supporting additional hangers therefrom, but further readily provides for nesting of hangers. There is therefore a great need in the art for a hanger providing such characteristics.

[0011] Accordingly, there is now provided with this invention an improved clothing hanger that effectively overcomes the aforementioned difficulties and longstanding problems

discussed above. These problems have been solved in a simple, convenient, and highly effective way by which to form a clothing hanger.

SUMMARY OF THE INVENTION

[0012] According to one aspect of the invention, a new and useful hanger having a hanger supporting means in the form of a cascade hook for supporting additional hangers therefrom, wherein the cascade hook facilitates the nesting of one hanger with another similar hanger is disclosed.

[0013] One embodiment of the present invention includes a garment hanger comprising a hanger frame comprising a hanger body, the hanger body having a front surface and a rear surface, a top and a bottom; a hook member extending from the top of the hanger body, the body having a hole formed therethrough, the hole having a front aperture formed in the front surface and a rear aperture formed in the rear surface; the body having a cascade hook member extending from the front surface and disposed in front of the front aperture. In these embodiments, the hole is adapted to receive through the rear aperture a cascade hook member from a first identical garment hanger and the cascade hook member is adapted to be inserted into a rear aperture of a hole in a second identical garment hanger.

[0014] In certain embodiments, the cascade hook member has an inclined portion having a first end disposed at the bottom of the hole and a second end disposed opposite from the first end, and a second portion extending upwardly from the second end of the inclined portion.

[0015] In any of the foregoing embodiments, the cascade hook member may comprise a rear surface substantially facing the front surface of the body; a front surface substantially facing away from the front surface of the body. A projection of the cascade hook member onto a plane containing the front surface of the body may be shaped substantially the same as the front aperture, and the projection may have an area less than the area of the front aperture. The rear aperture may have an area greater than the area of the front aperture. There may also be a concavity formed in the rear surface of the cascade hook member.

[0016] Furthermore, in any of the foregoing embodiments, the cascade hook member may be adapted to be inserted through the hole of the second identical garment hanger and extend out of a front aperture of the hole of the second identical garment hanger. Upon being inserted through the hole of the second identical garment hanger, the front surface of the cascade hook member may abut a portion of a rear surface of a cascade hanger member of the second identical garment hanger.

[0017] A channel may be formed between a portion of the front surface of the cascade hook member and a portion of the rear surface of the cascade hook member of the second identical hanger. Similarly, a cavity may be formed between a portion of the front surface of the cascade hook member and a concavity formed in the rear surface of the cascade hook member of the second identical hanger. Where both a cavity and a channel are formed, the width of the channel may be smaller than the width of the cavity.

[0018] In a further embodiment of the invention, a garment hanger is disclosed comprising a hanger body having a front surface, a rear surface, and a hole therethrough, and a hook attached within the hole to the hanger body, wherein the hook

is adapted to articulate between a first position extending beyond the front surface and a second position extending beyond the rear surface.

[0019] In another embodiment of the invention, a pair of substantially identical nested first and second garment hangers are disclosed wherein each of the first and second garment hangers comprise a hanger body having a front surface, a rear surface, a hole therethrough, and a hook attached within the hole to the hanger body. The hook is adapted to articulate between a first position extending beyond the front surface and a second position extending beyond the rear surface. When the hook of the first hanger is in the first position, the hook extends into the hole of the second hanger and the front surface of the first hanger abuts a rear surface of the second hanger so that the first and second hangers are nested in a common horizontal plane relative to one another.

[0020] In yet another embodiment of the invention, a pair of substantially identical nested first and second garment hangers are disclosed wherein each of the first and second garment hangers comprise a hanger body having a front surface, a rear surface, a hole therein, and a hook attached within the hole to the hanger body. The hook is adapted to articulate between a first position extending beyond the front surface and a second position housed within the body. When the hook of the first hanger is in the second position, the front surface of the first hanger abuts a rear surface of the second hanger so that the first and the second hangers are nested in a common horizontal plane relative to one another.

[0021] These and other aspects of the subject invention will become more readily apparent to those having ordinary skill in the art from the following detailed description of the invention taken in conjunction with the drawings described herein. Additional objects of the present invention will become apparent from the following description.

[0022] The method and apparatus of the present invention will be better understood by reference to the following detailed discussion of specific embodiments and the attached figures which illustrate and exemplify such embodiments.

DESCRIPTION OF THE DRAWINGS

[0023] A specific embodiment of the present invention will be described with reference to the following drawings, wherein:

[0024] FIG. 1 is a front plan view of a preferred embodiment of the present invention.

[0025] FIG. 2 is a cross-sectional detail of the preferred embodiment depicted in FIG. 1.

[0026] FIG. 3 is a front plan view of two hangers of a preferred embodiment of the present invention shown in a nested configuration.

[0027] FIG. 4 is a cross-sectional detail of the hangers depicted in FIG. 3.

[0028] FIG. 5 is an orthogonal view of two hangers of a preferred embodiment of the present invention shown in a nested configuration.

[0029] FIG. 6 is an orthogonal view of two hangers of a preferred embodiment of the present invention shown in a cascaded configuration.

[0030] FIG. 7 is a substantially rear orthogonal view of a preferred embodiment of the present invention.

[0031] FIG. 8 is an orthogonal view of another embodiment of a hanger of the present invention.

[0032] FIG. 9 is an enlarged view of a hole in a body of an embodiment of a hanger of the present invention.

[0033] FIG. 10 is an orthogonal view of a hook of an embodiment of a hanger of the present invention.

[0034] FIG. 11 is an orthogonal view of the hook in the body of FIG. 9.

[0035] FIG. 12 is an orthogonal view of the hook housed within the body of a hanger of the present invention.

[0036] FIG. 12A is a sectional view of FIG. 12.

[0037] FIG. 13 is an orthogonal view of the hook extending beyond the rear surface of a hanger of the present invention.

[0038] FIG. 13A is a sectional view of FIG. 13.

[0039] FIG. 14 is an orthogonal view of a pair of nested hangers of FIG. 8.

[0040] FIG. 14A is a sectional view of FIG. 14.

[0041] FIG. 15 is an orthogonal view of a pair of hangers of FIG. 8 showing one hanger hanging from another.

DESCRIPTION OF THE PREFERRED EMBODIMENT

[0042] The following preferred embodiment as exemplified by the drawings is illustrative of the invention and is not intended to limit the invention as encompassed by the claims of this application. A nestable clothes hanger with an integrated articulating hook is disclosed herein.

[0043] Referring generally to the Figures, the hanger generally comprises hanger frame 1 and hook member 2 extending upwardly therefrom. Hanger frame comprises body 4 and arms 5 extending from each side of body 4. Hook member 2 is connected to frame 1 via vertical portion 3.

[0044] Hanger body 4 includes a generally planar front surface 10 and a rear surface 11 substantially collateral with front surface 10. Cascade hook 20, which may also be called a "finger", extends from front surface 10.

[0045] Cascade hook 20, shown in FIG. 1 and in cross section in FIG. 2, has a front surface 21 and a rear surface 22, a vertical portion 27 substantially collateral with front surface 10 of hanger body 4 and an inclined portion 28 extending upwardly and outwardly from front surface 10 of hanger body 4. Inclined portion 28 may form an angle of less than 90 degrees from vertical (i.e., less than 90 degrees from the plane of front surface 10). Cascade hook 20 may omit a vertical portion, and inclined portion 28 may be arranged perpendicularly to front surface 10 without departing from the invention disclosed herein, provided that cascade hook 20 may function to support additional hangers therefrom and allows for nesting of hangers, as will be described in greater detail below.

[0046] Cascade hook 20 may include a concavity 23, which may be formed at the intersection of the vertical portion 27 and inclined portion 28. Alternatively, concavity 23 may be omitted.

[0047] Body 4 includes a hole 26. The hole may either be formed completely through the body, or alternatively, may be only a recess in the body. When the hole is through the body, the hole 26 has a rear aperture 24 formed in the rear surface 11 and a front aperture 25 formed in front surface 10. Rear aperture 24 may include chamfer 30 (depicted more clearly in FIG. 7). Each of the front and rear apertures have a certain area, that is, each has a certain measure of the planar extent it defines. Cascade hook 20 is shaped substantially the same as front aperture 25, that is, if one projects the shape of cascade hook 20 on the same plane as that occupied by aperture 25 (which is the same as the plane of front surface 10), the projected shape of cascade hook 20 will be substantially the same as the shape of aperture 25. One in the art will readily understand that the projection disclosed herein is not a physi-

cal structure, but instead an orthographic projection, that is, a representation of the three dimensional cascade hook **20** on a planar surface corresponding to the plane containing aperture **25**.

[0048] Front surface **10** may also be curved, in which case apertures **24** and **25** would likewise be curved. In this case, the projection of cascade hook **20** onto a plane would have substantially the same shape as a projection of aperture **25** onto the same plane.

[0049] The surface area of front surface **10** which is not occupied by cascade hook **20** may be at least approximately twice that of the surface area occupied by cascade hook **20**.

[0050] Referring now to FIGS. **3** and **4**, two hangers of one embodiment of the present invention may be seen in a nested configuration. Hanger **50** is placed in front of hanger **60**, which is nested with hanger **50**. Cascade hook **61** of hanger **60** extends through rear aperture **52** of hanger **50**, through hole **53**, and partially out front aperture **54** of hanger **50**. Front surface **60** of the inclined portion of cascade hook **61** abuts rear surface **55** of cascade hook **51**. Front surface **62** of hanger **60** abuts rear surface **56** of hanger **50**. Cascade hook **61** may be dimensioned to closely conform to the dimensions of front aperture **54**, thereby nesting hanger **60** to hanger **50**. Rear aperture **53** may be dimensioned larger than front aperture **54** to more easily receive cascade hook **61** in hole **53**.

[0051] When nested as shown in FIGS. **3**, **4**, and **5**, cascade hooks **51** and **61** form channel **71** therebetween, terminating in cavity **72**, formed in part by concavity **73** and the front face of cascade hook **61**. Concavity **73** may be dimensioned so as to hold a hook member of another hanger therein, while channel **71** may be of smaller dimensions, prohibiting a hook member present in cavity **72** from moving through channel **71**, thereby maintaining the hook member in cavity **72**. Cavity **72** may be dimensioned to closely approximate the diameter of hook member **2**, depicted, for example, in FIGS. **1** and **6**.

[0052] Another embodiment of the invention is depicted in FIGS. **8-15**. As shown specifically in FIGS. **8** and **9**, the hook **20** may be attached within the hole **26** of the body. As shown in FIGS. **9** and **10**, one manner of attaching the hook within the hole may be by providing a pin hole **80** for receiving a projection **82** of the hook. In this embodiment, the hook may have arms **84** extending from each of the projections adapted for resting upon and being supported by the lower portion **86** of the hole. The arms **84** of the hook are joined to each other by an arch **88** completing the hook of this embodiment.

[0053] FIG. **11** depicts an enlarged orthogonal view of the hook extending beyond the front surface of the hanger for another hanger to hang therefrom.

[0054] As further illustrated in FIGS. **12** and **12A**, the hook may articulate between a first position extending beyond the front surface of the hanger for another hanger to hang therefrom (FIG. **11**) to a second position in which the hook is completely housed within the body of the hanger. The articulation is accomplished by the pivoting of the projections within the pinholes. When the hook is in the position thus depicted, multiple hangers may be stored in a nested fashion for minimizing the storage space they occupy.

[0055] As more specifically shown in FIG. **12A**, the hanger may be formed by joining two portions along a joint **90**. Alternatively, the hanger may be made monolithically with a hole therethrough, as shown in FIG. **13A**.

[0056] FIG. **13** shows a further embodiment of the present invention in which the hook may articulate between a first position extending beyond the front surface of the hanger for

another hanger to hang therefrom (FIG. **11**) to a second position in which the hook extends beyond the rear surface of the hanger. The articulation is accomplished by the pivoting of the projections within the pinholes. Another hanger may be hung from the hook when it extends beyond the rear surface of the hanger. In this embodiment, an intermediate position is provided in which the hook may be housed within the body for storing multiple hangers in a nested fashion thereby minimizing the storage space they occupy.

[0057] FIGS. **14** and **14A** illustrate an alternative way to nesting the hangers from that of positioning the hooks within the body. In this embodiment, the hangers may be nested with the hook in a position extending beyond the front surface of the hanger. As shown therein, the hook extending beyond the front surface of a first hanger extends into the hole of a second hanger positioned in front of the front surface of the first hanger. The front surface of the first hanger abuts a rear surface of the second hanger so that the first and the second hangers are nested in a common horizontal plane relative to one another.

[0058] Although the particular embodiments shown and described above will prove to be useful in many applications in the clothing storage art to which the present invention pertains, further modifications of the present invention will occur to persons skilled in the art. All such modifications are deemed to be within the scope and spirit of the present invention as defined by the appended claims.

What is claimed is:

1. A garment hanger, comprising:

- a. a hanger body having a front surface, a rear surface, and a hole therethrough; and
- b. a hook attached within the hole to the hanger body, wherein said hook is adapted to articulate between a first position extending beyond said front surface and a second position extending beyond said rear surface.

2. The hanger of claim **1**, wherein when said hook is in said first position, said hook is further adapted to be inserted into a hole of a second identical hanger.

3. The hanger of claim **2**, wherein when said hook is in said first position, said hook is further adapted to hang another hanger adjacent said front surface of said hanger body.

4. The hanger of claim **1**, wherein when said hook is in said second position, said hook is further adapted to be inserted into a hole of a second identical hanger.

5. The hanger of claim **4**, wherein when said hook is in said second position, said hook is further adapted to hang another hanger substantially perpendicular to said rear surface of said hanger body.

6. The hanger of claim **1**, wherein said hook has an intermediate position between said first position and said second position, and wherein when said hook is in said intermediate position said hook is completely housed within said hole.

7. A pair of substantially identical nested first and second garment hangers, each said first and second garment hanger comprising:

- a. a hanger body having a front surface, a rear surface, and a hole therethrough; and
- b. a hook attached within the hole to the hanger body, wherein said hook is adapted to articulate between a first position extending beyond said front surface and a second position extending beyond said rear surface;

wherein when said hook of said first hanger is in said first position, said hook extends into said hole of said second hanger and said front surface of said first hanger abuts a

rear surface of said second hanger so that said first and second hangers are nested in a common horizontal plane relative to one another.

8. The hanger of claim **7**, wherein said hook has an intermediate position between said first position and said second position, and wherein when said hook is in said intermediate position said hook is completely housed within said hole.

9. A pair of substantially identical nested first and second garment hangers, each said first and second garment hanger comprising:

a. a hanger body having a front surface, a rear surface, and a hole therein; and

b. a hook attached within said hole to said hanger body, wherein said hook is adapted to articulate between a first position extending beyond said front surface and a second position housed within said body;

wherein when said hook of said first hanger is in said second position, said front surface of said first hanger abuts a rear surface of said second hanger so that said first and second hangers are nested in a common horizontal plane relative to one another.

10. The hanger of claim **9**, wherein said hole is a recess within said body.

11. The hanger of claim **10**, wherein when said hook is in said first position, said hook is further adapted to hang another hanger adjacent said front surface of said hanger body.

12. The hanger of claim **9**, wherein when said hook is in said second position, said hook is further adapted to be inserted into a hole of a second identical hanger.

13. The hanger of claim **12**, wherein when said hook is in said second position, said hook is further adapted to hang another hanger substantially perpendicular to said rear surface of said hanger body.

14. The hanger of claim **9**, wherein said hook has an intermediate position between said first position and said second position, and wherein when said hook is in said intermediate position said hook is partially housed within said hole.

15. The hanger of claim **9**, wherein said hook defines an aperture.

16. The hanger of claim **15**, wherein said aperture is perpendicular to said front surface when said hook is in said first position.

17. The hanger of claim **9**, wherein said hook has a arcuate top portion.

18. The hanger of claim **10**, wherein said hook has a arcuate top portion.

19. The hanger of claim **11**, wherein said hook has a arcuate top portion.

20. The hanger of claim **15**, wherein said hook has a arcuate top portion.

* * * * *