

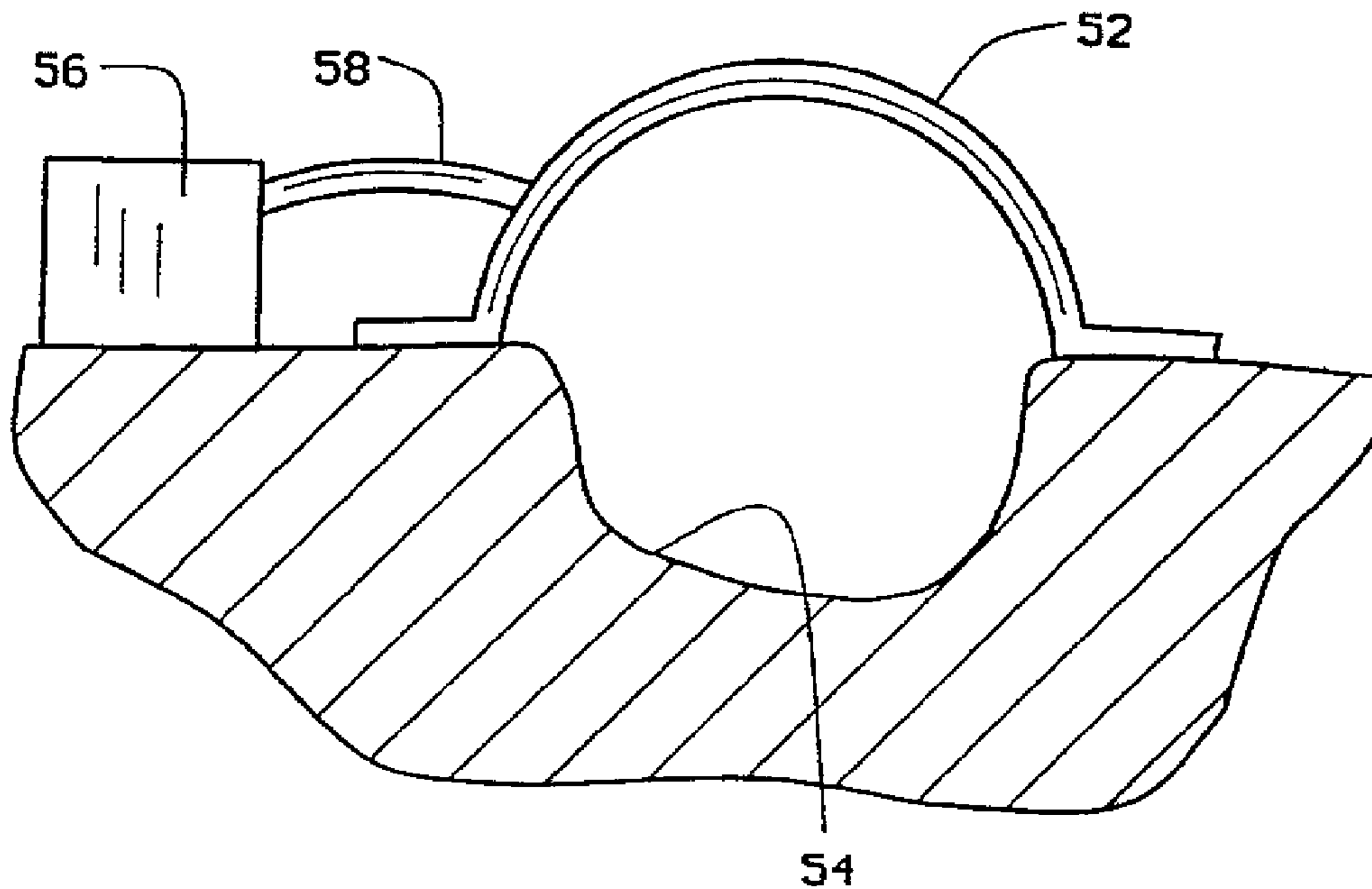

(86) Date de dépôt PCT/PCT Filing Date: 1995/03/27
 (87) Date publication PCT/PCT Publication Date: 1995/10/12
 (45) Date de délivrance/Issue Date: 2005/07/26
 (85) Entrée phase nationale/National Entry: 1996/09/27
 (86) N° demande PCT/PCT Application No.: US 1995/003480
 (87) N° publication PCT/PCT Publication No.: 1995/026690
 (30) Priorités/Priorities: 1994/03/30 (08/220,186) US;
 1995/03/22 (08/408,423) US

(51) Cl.Int.⁶/Int.Cl.⁶ A61B 17/00, A61B 19/00
 (72) Inventeur/Inventor:
 KHOURI, ROGER K., US
 (73) Propriétaire/Owner:
 BRAVA, LLC, US
 (74) Agent: OSLER, HOSKIN & HARCOURT LLP

(54) Titre : PROCEDE ET APPAREIL DESTINES A FAVORISER L'ELARGISSEMENT DE TISSUS MOUS ET LA
 CICATRISATION DES PLAIES
 (54) Title: METHOD AND APPARATUS FOR PROMOTING SOFT TISSUE ENLARGEMENT AND WOUND HEALING



(57) **Abrégé/Abstract:**

An apparatus and method for healing open wounds through enlargement of soft tissue surrounding said wound is comprised of a dome (12) configured to fit over the wound and at least a portion of the surrounding soft tissue. The dome (12) has a rim (14) with a surface area equal to or greater than the normal area of the dome opening to prevent medical complications caused by excessive pressure to the skin. A gasket (46) or other cushioning material may be provided about the periphery of the dome (12) for patient comfort and improved seal. The dome (12) also includes a vacuum pump (20) with a power source (22), pressure sensor (24), and servomechanism (26) for regulating the pressure within the dome (12) to any one of several protocols using pressures which might temporarily exceed non-damaging levels.



INTERNATIONAL APPLICATION PUBLISHED UNDER THE PATENT COOPERATION TREATY (PCT)

<p>(51) International Patent Classification⁶: A61B 19/00 2186725</p>	<p>A1</p>	<p>(11) International Publication Number: WO 95/26690 (43) International Publication Date: 12 October 1995 (12.10.95)</p>
<p>(21) International Application Number: PCT/US95/03480 (22) International Filing Date: 27 March 1995 (27.03.95) (30) Priority Data: 08/220,186 30 March 1994 (30.03.94) US 08/408,423 22 March 1995 (22.03.95) US (71) Applicant: KHOURI BIOMEDICAL RESEARCH, INC. [US/US]; 2 Kingsbury Place, St. Louis, MO 63112 (US). (72) Inventor: KHOURI, Roger, K.; 2 Kingsbury Place, St. Louis, MO 63112 (US). (74) Agents: HAFERKAMP, Richard, E. et al.; Rogers, Howell & Haferkamp, Suite 1400, 7733 Forsyth Boulevard, St. Louis, MO 63105 (US).</p>	<p>(81) Designated States: AM, AU, BB, BG, BR, BY, CA, CN, CZ, EE, FI, GE, HU, IS, JP, KE, KG, KP, KR, KZ, LK, LR, LT, LV, MD, MG, MN, MW, MX, NO, NZ, PL, RO, RU, SD, SG, SI, SK, TJ, TM, TT, UA, UG, UZ, VN, European patent (AT, BE, CH, DE, DK, ES, FR, GB, GR, IE, IT, LU, MC, NL, PT, SE), OAPI patent (BF, BJ, CF, CG, CI, CM, GA, GN, ML, MR, NE, SN, TD, TG), ARIPO patent (KE, MW, SD, SZ, UG). Published <i>With international search report.</i> <i>With amended claims and statement.</i></p>	

(54) Title: METHOD AND APPARATUS FOR PROMOTING SOFT TISSUE ENLARGEMENT AND WOUND HEALING

(57) Abstract

An apparatus and method for healing open wounds through enlargement of soft tissue surrounding said wound is comprised of a dome (12) configured to fit over the wound and at least a portion of the surrounding soft tissue. The dome (12) has a rim (14) with a surface area equal to or greater than the normal area of the dome opening to prevent medical complications caused by excessive pressure to the skin. A gasket (46) or other cushioning material may be provided about the periphery of the dome (12) for patient comfort and improved seal. The dome (12) also includes a vacuum pump (20) with a power source (22), pressure sensor (24), and servomechanism (26) for regulating the pressure within the dome (12) to any one of several protocols using pressures which might temporarily exceed non-damaging levels.

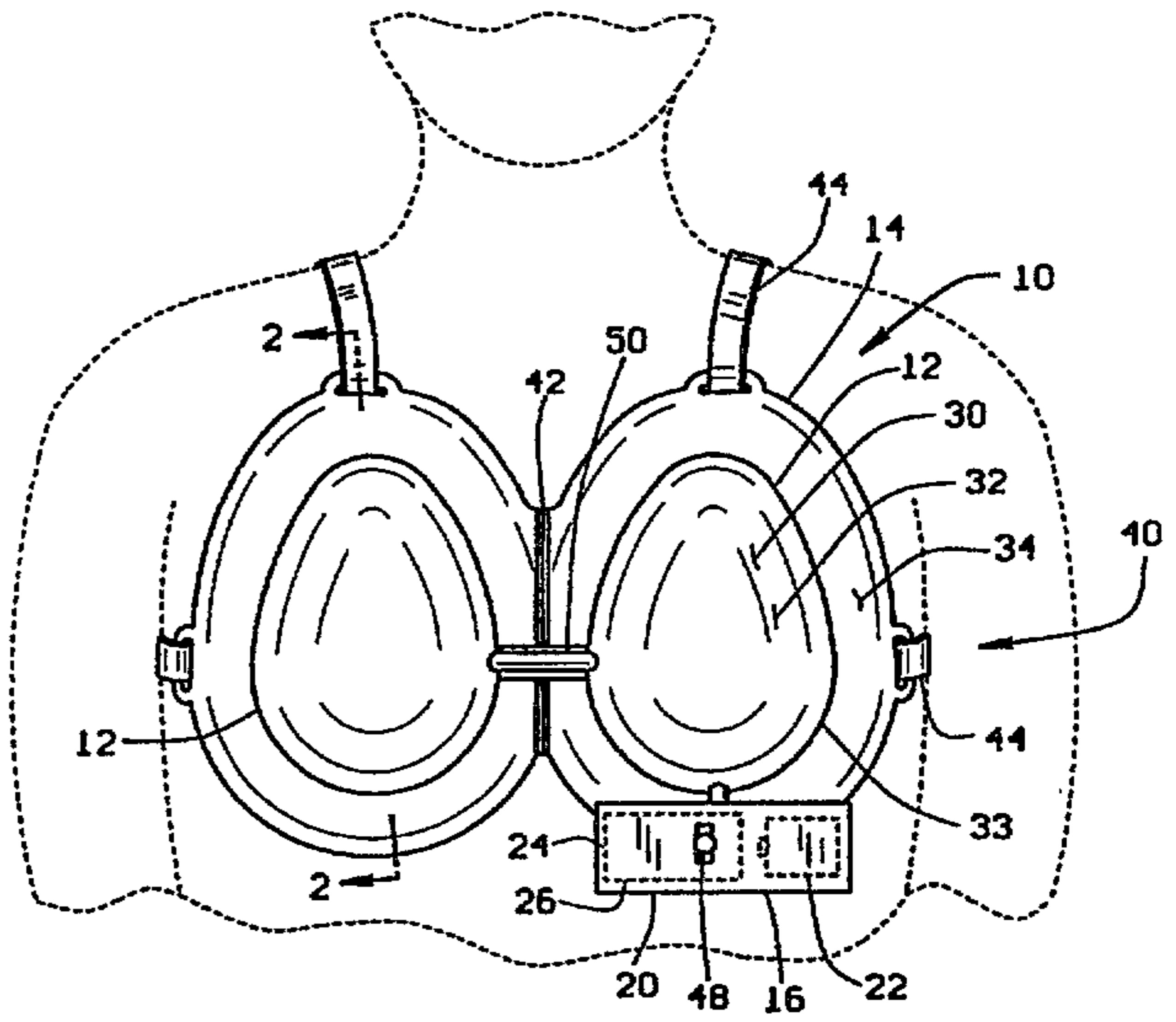

METHOD AND APPARATUS FOR PROMOTING SOFT TISSUE
ENLARGEMENT AND WOUND HEALING

Background and Summary of the Invention

There are numerous instances where persons desire enlargement of the soft tissues in their bodies. One such instance is for the replacement of one or both
5 breasts amputated during a mastectomy in order to restore physiological symmetry and psychological well-being. Other instances are for correction of natural abnormalities such as dimpling. Still other instances are for augmentation of physical attributes to improve
10 cosmetics and self-esteem. These latter soft tissue enlargements are principally directed to breast enlargement in females and penis enlargement in males.

Prosthetic implants have been developed for insertion below the skin. However, the severity of the
15 potential complications including scarring, implant rupture, capsular contracture, necrosis and implant migration as well as the recent adverse publicity thereof

2186725

2

have significantly reduced the desirability of these implants. Thus, there is a societal need for other means to obtain soft tissue enlargement.

Some soft tissue enlargements occur naturally.

5 For instance, during pregnancy the skin over a woman's abdominal region enlarges approximately nine times its previous area to accommodate the fetus without a proportional decrease in skin thickness. In other words, the abdominal skin tissue actually enlarges and does not
10 merely stretch during pregnancy. Similarly, the skin will expand to accommodate any growth under the skin.

In the past, plastic surgeons have used this phenomena to their advantage to expand skin in order to accommodate prosthetic implants or provide tissue to
15 close wound defects. To conduct this procedure, the surgeon inserts a balloon beneath the skin in the area where additional skin is desired. By progressively expanding the balloon, the skin first stretches and eventually actually grows to accommodate the increased
20 volume underneath it. When the desired amount of skin is formed, the balloon is deflated and removed, and the implant is inserted into the cavity left by the balloon. Also, the excess skin can be used to cover a wound defect, an ulcer or a depressed scar. Similar methods
25 have been used by African native tribes to enlarge lips, nostrils, and earlobes.

Other surgical techniques have used tissue expansion to achieve other types of soft tissue growth. For instance, balloons have been successfully situated
30 underneath nerves, veins, tendons, and the like to expand and thereby elongate these tissues to repair damage and alleviate various abnormalities.

A more advanced surgical method is known as callotasis distraction osteogenesis or limb lengthening.
35 This method comprises cutting the bone about its periphery at the location where lengthening is desired,

leaving the tissues inside and around the bone intact. Brackets are attached to the bone on each side of the separation, and the bone segments are slowly pulled away from one another while remaining integral over a period
5 of several months. Not only does this cause the mended bone to be longer, but also the soft tissue surrounding the bone actually grows to accommodate the increased limb length. Similar methods have been used by African native tribes to lengthen necks for cosmetic purposes.

10 Each of these above-mentioned apparatuses and methods requires an invasive surgical technique to accomplish the soft tissue expansion. Invasive techniques increase the likelihood of the complications associated with the procedure including those mentioned
15 above with respect to implant surgery. In addition, the expense of surgery precludes many persons having their abnormalities corrected or physical attributes enhanced.

Other soft tissue enlargement techniques have been developed which use other mechanisms to cause the
20 enlargement. For instance, an instrument and technique have been developed for the non-surgical correction of inverted nipples due to short lactiferous ducts. The instrument is comprised of a cup having an internal volume shaped like that of the final desired nipple. The
25 user places the cup over the inverted nipple, pumps the air out of the cup with a syringe and adjusts the vacuum within the cup using a check valve to just below the threshold of discomfort. Thus attached, the device puts the lactiferous ducts in tension and extends them
30 sufficiently after two to three months of wear at 8-12 hours per day.

Although this device is sufficient for its intended purpose, it is not suitable for general soft tissue enlargement. Laceration and contusion can occur
35 if too strong of a suction is applied to soft tissue. As the pressure within the inverted nipple instrument is not

2186725

PARIS

4

regulated, contusion or laceration can occur. When a vacuum is developed within the cup of the instrument, an equal and opposite force is applied to the patient about the rim of the cup. Excessive contact forces against the patient can cause ulceration, laceration, and contusions. As the contact forces are not regulated in the nipple instrument, these further complications also can occur. In addition, general soft tissue enlargement is not feasible with the instrument due to the size and shape of the cup.

Another prior art device is disclosed in U.S. Patent No. 936,434 as a device for enlarging a woman's breasts. This device included a pair of cups for placement on the breasts and a pump for exhausting the air. However, this patent provides no teaching as to the pressures to be used, the potential danger to the skin tissues, or any suggestions as to how the device is to be retained in place during use. Apparently, the device is used in a clinical setting and is not suitable for long term ambulatory wear such as for 8-10 hours. As the patent suggests that the vacuum acts to cause the veins and arteries to engorge, thereby nourishing the breasts, it is clear that the patentee is suggesting that the breast tissue actually expands through this expansion of blood vessels alone. This patent has been the subject of ridicule by at least one medical authority. See "An Anthology Of Plastic Surgery" edited by Harry Hayes, Jr., M.D., Section 6, "Quackery and Nostrums" pub. 1986 by Aspen Publishers, Rockville, Maryland.

Finally, another prior art device although notorious is worthy of note. This device is commonly referred to as a penis pump and is sold primarily as a novelty as its long-term enlargement efficacy has never been proven and is in fact universally disclaimed by its distributors. The device is comprised of a cylinder having one open end into which the penis is inserted and

a pump attached to it such that a vacuum can be created within the cylinder. Not only does this device have the same drawbacks as the nipple instrument with respect to potential complications, but also it is unlikely that sufficient vacuum can be maintained by the device to cause any notable long-term soft tissue enlargement. Further, this device is apparently designed to accomplish two tasks unrelated to enlargement. First, the device is used for stimulation and sexual gratification. Second, the device is used to promote erection by drawing blood into the penis.

There is also another condition routinely experienced by many patients in which the generation of soft tissue is important. That condition evolves from injuries or diseases which produce wound infections or ulcers which have a tendency to exude bodily fluids and resist healing. At least one effort has been made in the prior art, as known by the inventor herein, to address this problem. This prior art solution involves the use of an occlusive, or airtight, dressing covering the wound coupled with a suctioning of fluid from the wound either once or repeatedly in order to dry it out and create an environment more conducive to wound healing. It is not believed that this prior art considers the problems of excessive contact forces against the patient's skin which can cause ulceration, laceration, and contusions. Also, this prior art teaching is not focused on soft tissue enlargement through the use of a vacuum alone and instead relies at least in part on the use of suction for removing wound fluid and creating an environment that promotes healing. The importance of enlarging the surrounding soft tissue to close the wound is not a clear focus of this prior art method.

Most of these prior art devices and methods have failed to achieve long term soft tissue enlargement while preventing damage to the soft tissue being enlarged, as

2186725

6

well as surrounding tissue. The inventor herein has succeeded in designing and developing a new generalized method and apparatus for soft tissue enlargement which prevents damage to soft tissue. The apparatus used for
5 this enlargement is comprised of a rigid fluid-impervious dome having a rim about its periphery and a vacuum pump for reducing pressure to thereby apply a distracting force to the soft tissue isolated by and within the dome. The rim has sufficient surface area such that the
10 pressure applied to the patient by the rim is less than or equal to the negative pressure applied to the soft tissue under the dome. Thus, as long as pressure within the dome is regulated to a limit below which medical complications cannot occur, the opposing contact pressure
15 against the patient is below this threshold as well. With this approach, damage is avoided not only to the soft tissue being enlarged, but the surrounding tissue as well. In the preferred embodiment of the apparatus, the vacuum pump has a self-contained power source. In
20 addition, a pressure sensor and servomechanism control the pump such that the vacuum within the dome is maintained at a magnitude less than 35 mm Hg. Variant embodiments may be configured to fit over and enlarge a human breast, a human penis, an infected wound, open
25 sore, ulcer, or any other desired area.

The method of use is comprised of the steps of attaching the dome to the location of desired enlargement, and creating a vacuum within the dome. The vacuum should be maintained for a minimum of eight hours
30 per day and results should be sufficient after several months.

While the practical advantages and features of the present invention and method have been briefly described above, a greater understanding of the novel and unique
35 features of the invention may be obtained by referring to

2186725

7

the drawings and Detailed Description of the Preferred Embodiment which follow.

Brief Description of the Drawings

Figure 1 is a front elevation view of the soft tissue enlargement apparatus of the present invention, showing the breast augmentation embodiment;

Figure 2 is a cross-sectional view of the breast enlargement embodiment taken in the plane of line 2-2 of Figure 1;

Figure 3 is a cross-sectional schematic of a dome and soft tissue in the early stages of enlargement;

Figure 4 is a cross-sectional schematic of a dome and soft tissue in the latter stages of enlargement;

Figure 5 is an orthographic projection of the penile augmentation embodiment of the present invention; and

Figure 6 is a partial cross-sectional view of a dome in place over an open wound.

Detailed Description of the Preferred Embodiment

The soft tissue enlargement apparatus 10 is generally comprised of a dome 12 having a rim 14 and vacuum pump assembly 16 for creating a vacuum within the dome. Although the vacuum pump assembly 16 may be a separate hand-held pump in one variant embodiment, in the preferred embodiment the vacuum pump assembly 16 is a self-contained vacuum pump 20 with an independent power source 22, pressure sensor 24, and servomechanism 26 for driving, regulating and controlling the vacuum pump 20.

Regulation of the pressure within the dome is essential to prevent contusions caused by rupturing capillaries adjacent the surface of the skin, separating epidermis from dermis and causing blisters. Medical data suggest that these contusions and blisters will not occur if pressure within the dome is maintained at less than 25-35 mm Hg for extended periods of time. Thus, the vacuum pump 20 must be regulated to control the pressure

within the dome to within this limit. In addition, skin ulceration can occur if excessive contact pressures are applied thereto. Medical data suggest that a contact pressure less than 15-20 mm Hg may be applied indefinitely without such ulceration. However, contusions may occur due to positive contact pressures upon the skin at pressures for appreciable time periods above this ulceration limit. The preferred embodiment of the present invention was developed with these limits in mind and will not apply a continuous vacuum or a continuous contact pressure greater than 25-35 mm Hg.

Several forces are developed within the dome and about the rim as a result of evacuating air from the dome. A suction force is developed within the dome equal to the vacuum pressure multiplied by the enclosed tissue surface area 30. The vacuum or vacuum pressure may also be thought of as a negative pressure. The vector sum of the suction force upon the tissue surface area 30 may be called the normal force and is equal to the vacuum pressure multiplied by the normal area 32 of the dome opening, i.e., the area bounded by the periphery 33. An opposing force is imposed on the user by the rim 14 to balance the normal force and is equal but opposite to the normal force. The contact pressure of the rim 14 against the user is equal to this opposing force divided by the annular rim surface area 34, i.e., the surface area between the rim and patient which supports the dome's pressure. Therefore, if the rim surface area 34 is configured to be greater than or equal to the normal area 32 at the dome opening, then the contact pressure against the patient's skin will not exceed the magnitude of the vacuum pressure within the dome 12. Another physical phenomenon further aids in the enlargement forces upon the soft tissue under the dome 12. If the tissue only slightly protrudes into the dome as shown in Figure 3 and as is typically the initial condition, then

the surface area 30 under the dome is only slightly larger than the normal area 32 at the dome opening. Therefore, as the suction force is directly proportional to the surface area of the tissue under the dome, the suction force is only slightly larger than the normal force. As enlargement occurs, more tissue protrudes into the dome 12 as shown in Figure 4 thereby providing more surface area 30 under the dome. Because the surface area 30 under the dome is larger, the suction force generated is increased. Thus, the rate of enlargement increases as treatment continues.

One specific embodiment includes a dome 12 configured to fit over a human breast as shown in Figures 1 and 2. This embodiment includes a rim 14 having a surface area 34 greater than the normal area 32 of the dome opening thereby preventing medical complications to the soft tissue as long as the pressure is properly regulated within the dome 12. The pressure reducing means 16 is located underneath the patient's breast, so that the apparatus 10 may be hidden under loose-fitting clothes. As with the general embodiment, the vacuum pump assembly 16 of this embodiment is preferably comprised of a vacuum pump 20 with a power source 22, a pressure sensor 24 and servomechanism 26 to drive and control the vacuum pump and to regulate the pressure within the dome 12.

As shown in Figure 1, this specific embodiment may take the form of a bra 40 having two domes 12 spaced by a hinge 42. Straps 44 may be attached to the bra 40 to retain the bra 40 in place. A gasket 46 may also be included about the rim 14 to improve the patient's comfort and enhance the seal about the rim. In the preferred embodiment, this gasket 46 may be a silicone gel cushion or other soft, conforming type material. Petroleum jelly or other sealant gel may also be used to supplement or supplant the gasket. A manual override 48

is included on the vacuum pump assembly 16 so that the patient or doctor may vary the pressure below the optimal level so as to be more comfortable. Although two vacuum pump assemblies 16 may be used, one depending from each dome 12 so as to provide different pressures in the domes, the preferred embodiment places the domes in fluid communication with a conduit 50.

A second specific embodiment is shown in Figure 5 wherein the dome 12 is configured to fit over a human penis. As can be seen from the figure, this embodiment comprises essentially the same features as the bra embodiment described above. The principal differences between these embodiments are the configurations of the dome 12' and rim 14' as well as the positioning of the straps 44'.

As shown in Figure 6, a dome 52 may be conveniently located over an open wound 54. A pump 56 (including an appropriate control) draws a vacuum through a connecting tube 58 in substantially the same manner as has been explained above.

In order to use the invention, the patient places the dome over the area of desired enlargement and adjusts the straps for comfort. Then the patient simply turns the vacuum pump on and the device goes to work. These apparatuses are intended to be worn 8-12 hours per day and can be worn during sleep. After several months, notable and long-term enlargement should occur. When the desired enlargement is achieved, the use of the device may be suspended. If additional enlargement is desired, then use may be continued. Occasional use or use at a reduced pressure may also be desired to maintain the desired enlargement.

For alternate applications, such as in a hospital, clinic or other professional setting, the invention may be applied to the area of desired enlargement, or over an open wound or ulcer, and the vacuum pump and control

turned on in order to automatically apply an appropriate regimen of vacuum and rest. As noted above, a vacuum may be developed with the invention and maintained at a continuous negative pressure sufficient to provide tissue enlargement and yet not cause damage to surrounding soft tissue for extended time periods. Alternatively, a "cycling" regimen may be provided by the invention which may promote more rapid tissue enlargement. For example, the vacuum pump may be controlled to develop a pressure as high as 100 mm Hg for several minutes and then return to a much lower level considered to be safe for extended periods, such as between 15-20 or even 35 mm Hg. Upon further testing, other protocols for treatment or use may be found to produce an accelerated enlargement of soft tissue. The present invention should not be considered as limited to any particular protocol as the inventor contemplates that different protocols may be readily learned and utilized with the present invention.

There are various changes and modifications which may be made to the invention as would be apparent to those skilled in the art. However, these changes or modifications are included in the teaching of the disclosure and it is intended that the invention be limited only by the scope of the claims appended hereto.

The embodiments of the invention in which an exclusive property or privilege is claimed are defined as follows:

1. An apparatus for accelerating the closing of an open wound through the enlargement of a patient's soft tissue surrounding the open wound, said apparatus comprising:

a dome for enclosing said wound and at least a portion of the soft tissue surrounding said wound, said dome having an opening surrounded by a periphery defining a normal area, said dome having a rim for surrounding said open wound and soft tissue portion, said rim having a contact surface area configured for engaging the soft tissues, said contact surface area being substantially equal to or greater than said normal area, and

a vacuum pump configured for evacuating the dome to a pressure sufficient to promote growth enlargement of the soft tissue surrounding the open wound,

said dome being configured to withstand a vacuum sufficient to promote growth enlargement of the soft tissue surrounding the open wound.

2. The apparatus of Claim 1 wherein said dome is sufficiently rigid to withstand 35 mm Hg of negative pressure therewithin.

3. The apparatus of Claim 2 wherein said dome is sufficiently rigid to withstand temporary peak negative pressures of 100 mm Hg therewithin.

4. The apparatus of Claim 1 further comprising:

a regulator connected to said vacuum pump for maintaining a desired vacuum within said dome.

5. The apparatus of Claim 4 wherein said rim comprises a gasket.

6. An apparatus for accelerating the healing of an open wound through the enlargement of a patient's soft tissue at least partially surrounding said open wound, said apparatus comprising:

a dome for enclosing said open wound and at least a portion of said patient's soft tissue surrounding said wound,

said dome having an opening surrounded by a periphery defining a normal area and being sufficiently rigid to withstand a vacuum therein, and

said dome having a gasket for supporting said dome with a contact surface area engageable with tissue of the patient, said gasket being configured so that evacuation of the dome causes a contact pressure between the contact surface area of the gasket and the tissue engaged thereby, the contact surface area of the gasket being sufficiently large so that when the dome is evacuated to a pressure sufficient to promote growth enlargement of the soft tissue, then the contact pressure is insufficient to cause damage to the tissue.

7. The apparatus of Claim 6 wherein said contact surface area is substantially equal to or greater than said normal area.

8. The apparatus of Claim 7 further comprising a vacuum pump connected to said dome for generating the vacuum within said dome.

9. The apparatus of Claim 8 further comprising a regulator connected to said vacuum pump for use in varying the pressure in said dome to thereby permit different protocols of vacuum to be applied to said wound.

10. An apparatus for enlarging a patient's soft tissue comprising:

a dome for enclosing a portion of the patient's soft tissue desired to be enlarged, said dome having an opening surrounded by a periphery defining a normal area and being sufficiently rigid to withstand a vacuum therein; and

a rim adapted to surround said enclosed soft tissue for supporting said dome said rim having a contact surface area sufficiently large to provide a contact pressure less than a pressure which will cause damage to the tissue beneath said rim wherein said contact surface area is substantially equal to or greater than said normal area.

11. The apparatus of Claim 10 wherein said dome is sufficiently rigid to withstand 35 mm Hg of negative pressure therewithin.

12. The apparatus of Claim 11 further comprising a vacuum pump connected to said dome for reducing the pressure therewithin.

13. The apparatus of Claim 12 further comprising a regulator connected to said vacuum pump for maintaining a desired vacuum within said dome.

14. The apparatus of Claim 13 further comprising a gasket positioned between said rim and said patient for improved comfort and sealing of said dome.

15. The apparatus of Claim 14 further comprising a manual control for said vacuum pump to permit patient adjustment of the vacuum within the dome.

16. The apparatus of Claim 13 further comprising: a second one of said dome and rim combinations;

a hinge joining said rims; and

a fluid communication means connected between said domes to thereby equalize the vacuum therein.

17. The apparatus of Claim 16 wherein each dome is configured to surround a human breast.

18. The apparatus of Claim 13 further comprising:

a second one of said dome and rim combination;

a hinge joining said rims; and

a second vacuum pump and regulator connected to said second dome to thereby permit a different vacuum to be induced in each dome.

19. The apparatus of Claim 13 further comprising: a second one of said dome and rim combinations;

a hinge joining said rims; and

a fluid communication means connected between said domes to thereby equalize the vacuum therein.

20. The apparatus of Claim 13 wherein said dome is configured to surround a human penis.

21. An apparatus for enlarging a patient's soft tissue within the patient's breast, said apparatus comprising:

a pair of domes, each of said pair of domes being configured to surround one of the patient's breasts, each of said pair of domes having an opening surrounded by a periphery defining a normal area and being sufficiently rigid to withstand a vacuum therein; and

a pair of rims, each of said pair of rims adapted to surround one of the patient's breasts, each of said pair of rims for supporting one of said pair of domes with a contact surface area sufficiently large to provide a contact pressure less than a pressure which will cause damage to the tissue beneath said pair of rims wherein each of said contact surface areas is substantially equal to or greater than each of said normal areas.

22. The apparatus of Claim 21 wherein each of said pair of domes is sufficiently rigid to withstand 35 mm Hg of pressure therewithin.

23. The apparatus of Claim 22 further comprising a vacuum pump connected to each of said pair of domes for reducing the pressure therewithin.

24. A portable apparatus for enlarging a patient's soft tissue desired to be enlarged, said dome being sufficiently rigid to withstand a vacuum therein; and

said dome being supported from said patient by a contact surface area sufficiently large to provide a contact pressure less than a pressure which will cause damage to the patient's tissue in contact with said contact surface area.

25. The apparatus of Claim 24 further comprising a second dome, each of said domes being adapted to surround one of a woman's breasts.

26. The apparatus of Claim 25 wherein said contact surface area substantially surrounds each of said domes.

27. The apparatus of Claim 26 further comprising a portable vacuum pump connected to said domes for maintaining a vacuum in said domes.

28. The apparatus of Claim 27 further comprising a regulator connected to said portable vacuum pump for regulating the vacuum in said domes.

29. The apparatus of Claim 28 wherein said contact surface area includes a gasket substantially surrounding each of said domes.

30. The apparatus of Claim 29 wherein said gaskets are made of a soft, conforming material.

31. The apparatus of Claim 30 wherein said gaskets are made of silicone gel.

32. The apparatus of Claim 30 wherein said vacuum pump includes a pressure sensor for sensing the vacuum in the domes, and a servomechanism for regulating the pressure in said domes.

2186725

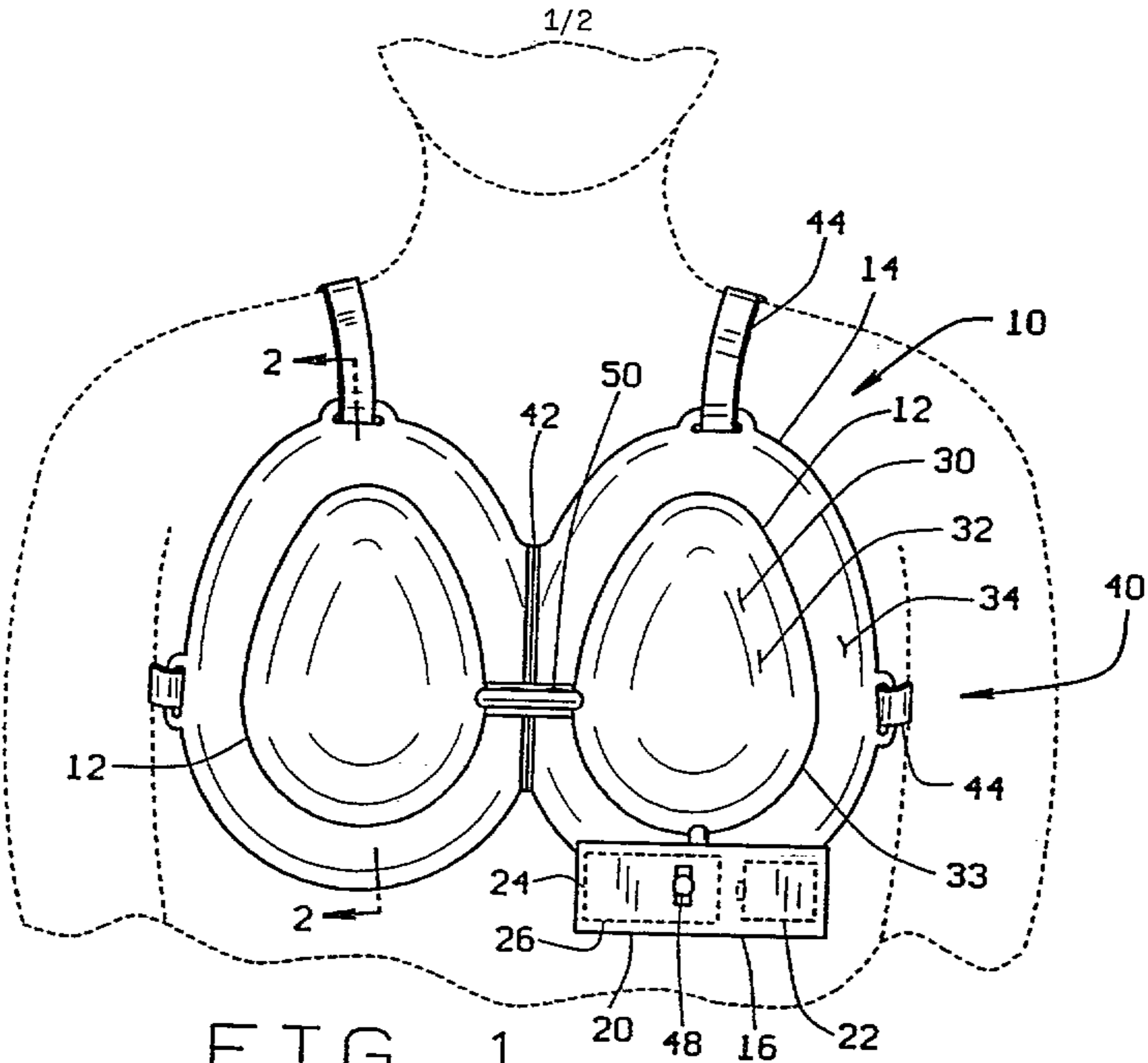

FIG. 1

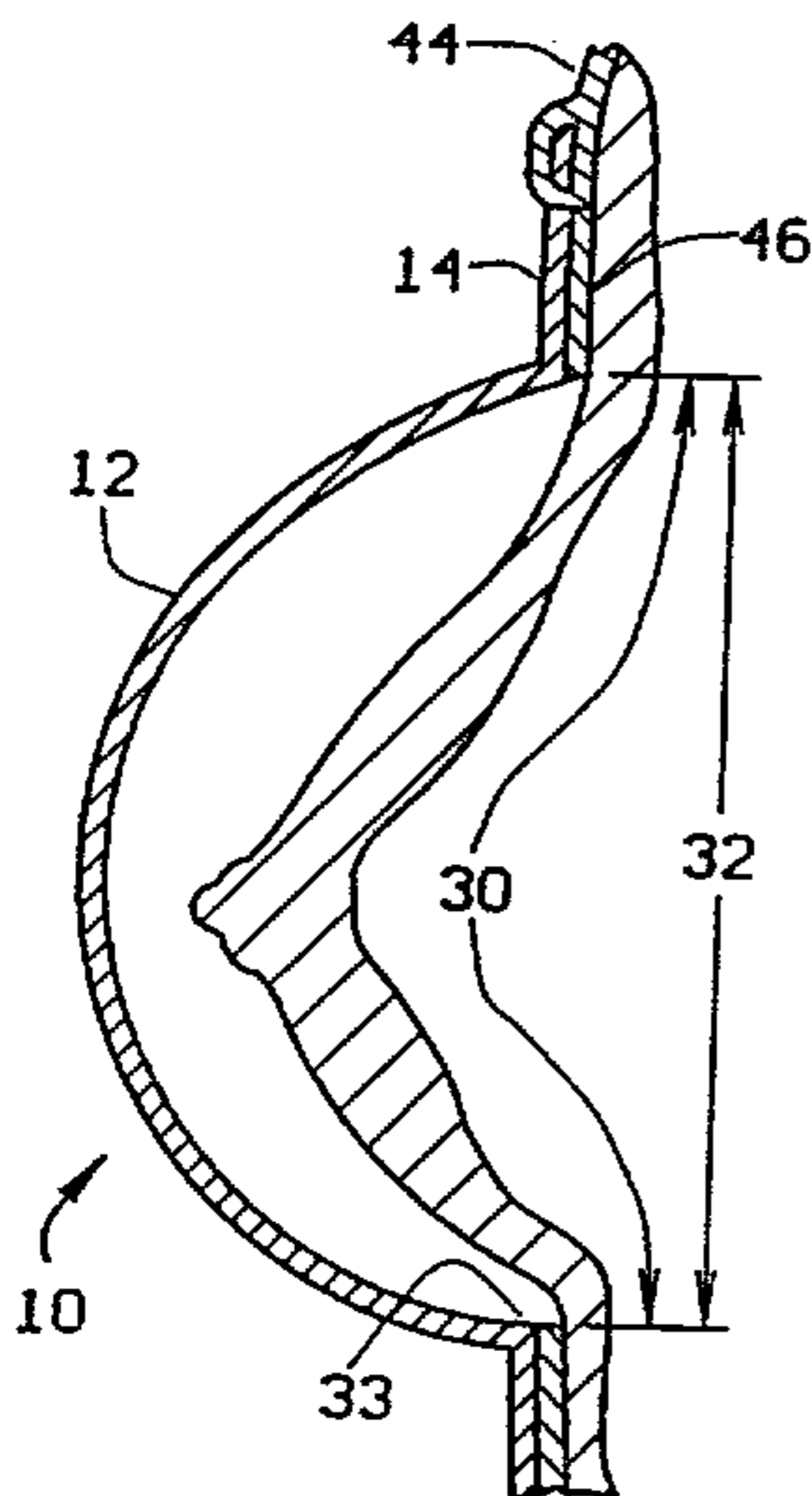

FIG. 2

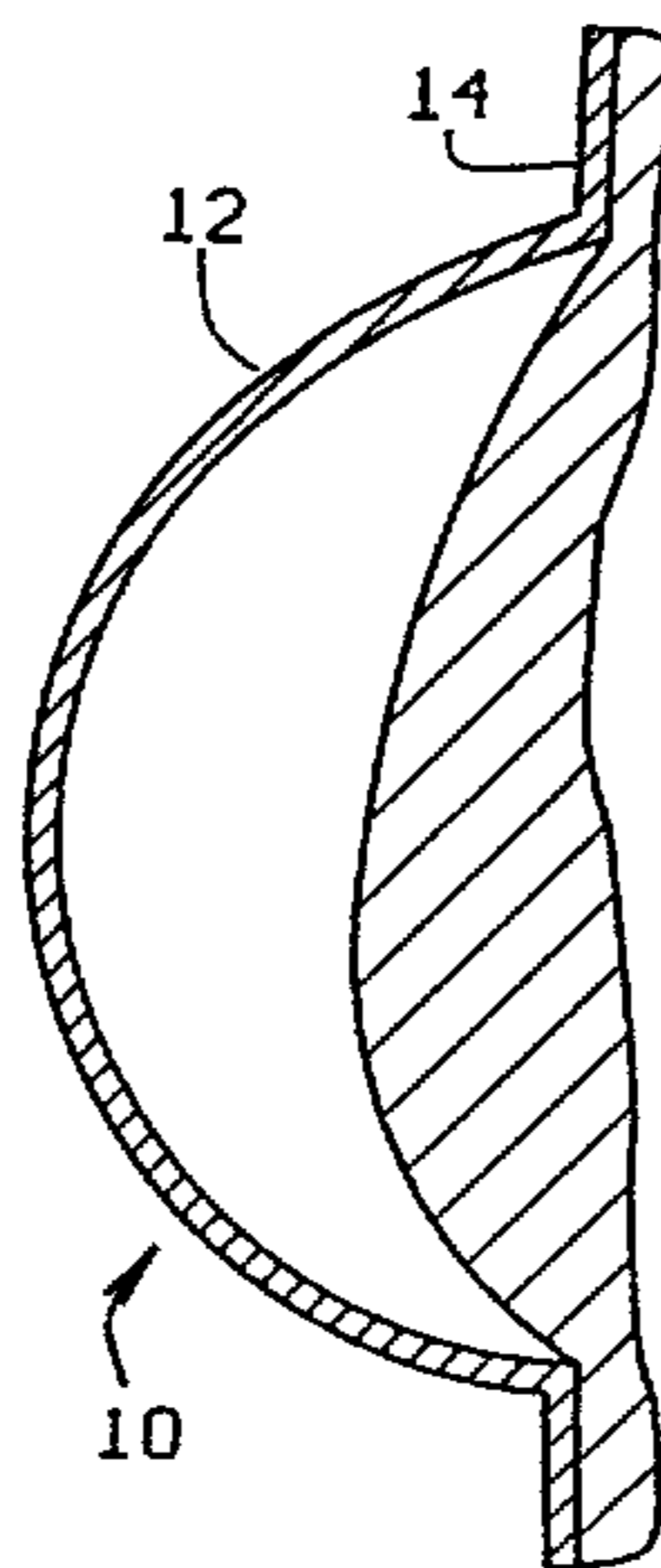

FIG. 3

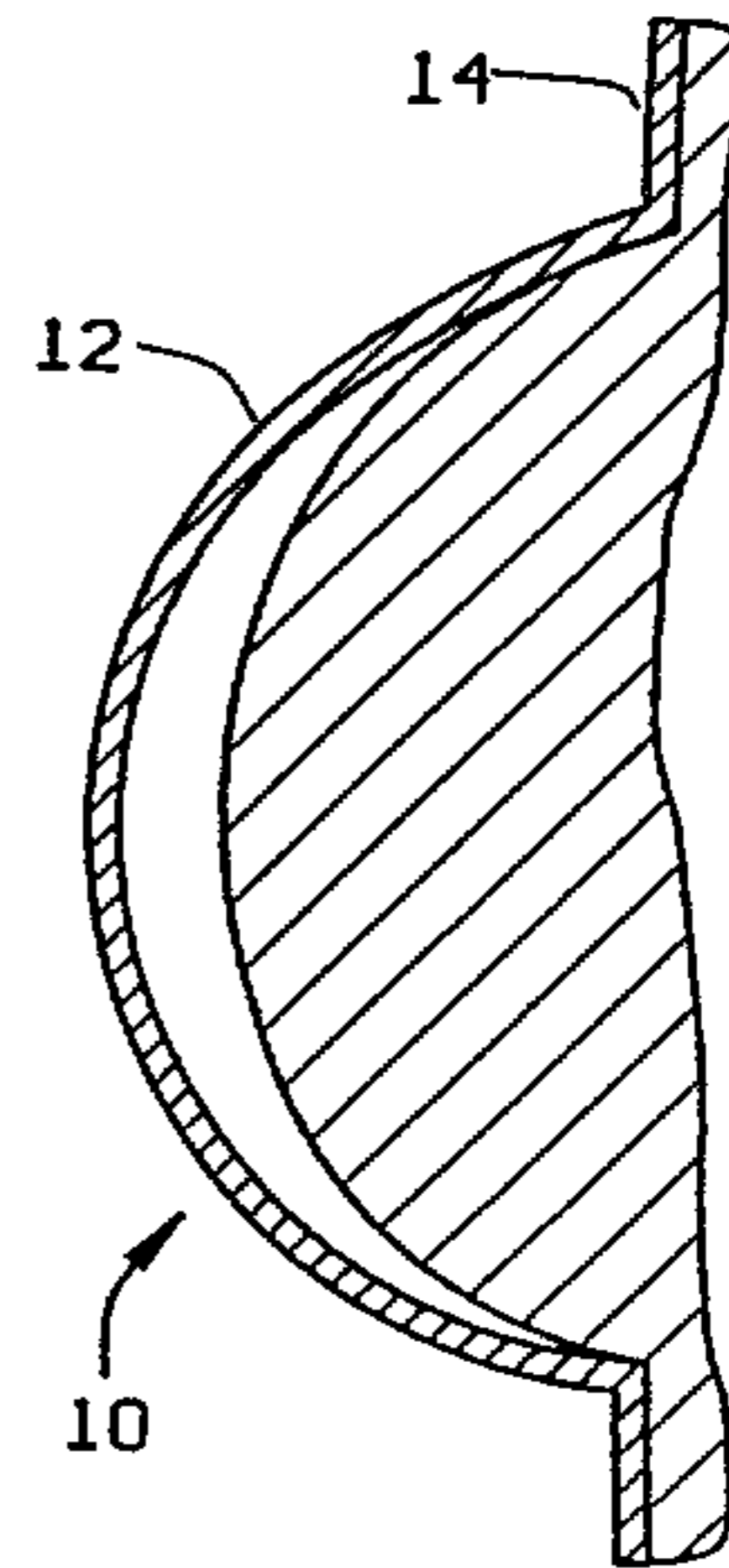

FIG. 4

2186725

2/2

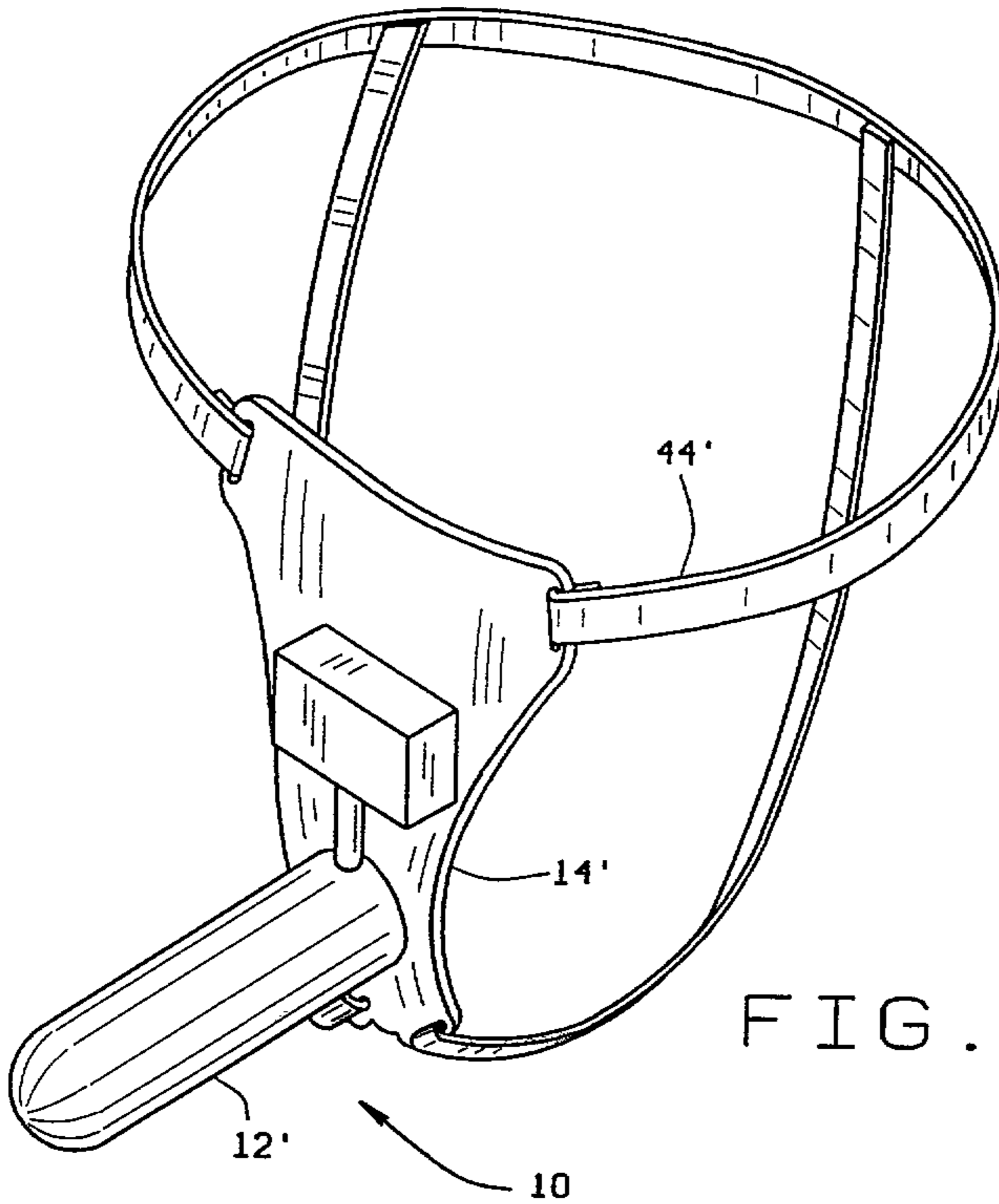

FIG. 5

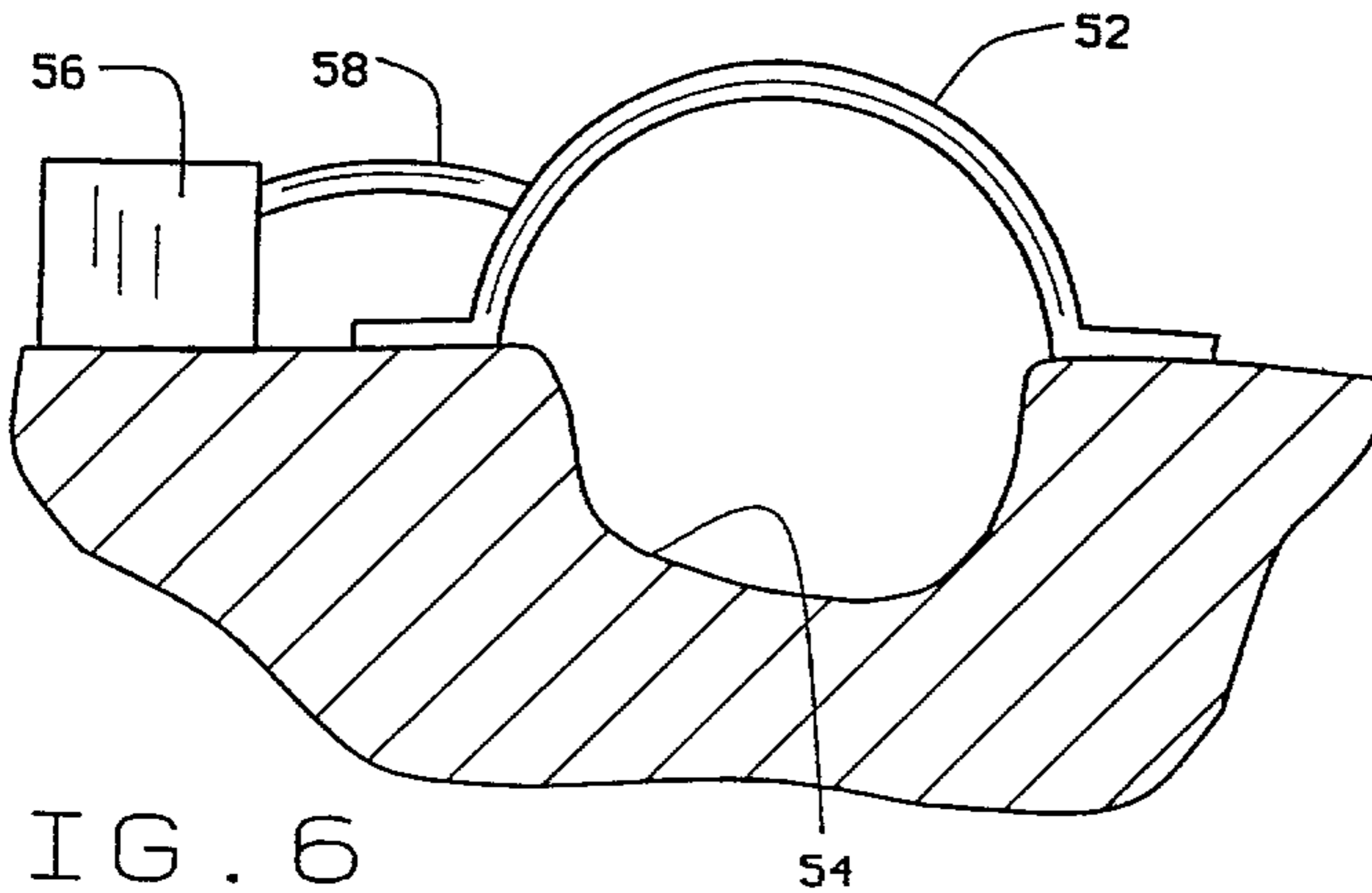

FIG. 6

